



Gigabit Interface Converter (GBIC) Module and Small Form-Factor Pluggable (SFP) GBIC Module Installation Information and Specifications

GBIC Product Numbers: WS-G5484, WS-G5486, WS-G5487, CWDM-GBIC-1470=, CWDM-GBIC-1490=, CWDM-GBIC-1510=, CWDM-GBIC-1530=, CWDM-GBIC-1550=, CWDM-GBIC-1570=, CWDM-GBIC-1590=, CWDM-GBIC-1610=

SFP Product Numbers: SFP-GE-F=, SFP-GE-S=, SFP-GE-L=, SFP-GE-Z=, GLC-SX-MM=, GLC-LH-SM=, GLC-ZX-SM=, GLC-T=, CWDM-SFP-1470=, CWDM-SFP-1490=, CWDM-SFP-1510=, CWDM-SFP-1530=, CWDM-SFP-1550=, CWDM-SFP-1570=, CWDM-SFP-1590=, CWDM-SFP-1610=.

Revision History Table

The Document Revision History table below, beginning with OL-5007-06, records technical changes to this document.

Document Version	Date	Change Summary
OL-5067-08	August, 2008	This version adds SFP module SFP-GE-F information.
OL-5067-07	April, 2007	This version adds Cisco 7201 support.
OL-5067-06	December, 2006	This version adds SFP module SFP-GE-S, SFP-GE-L, and SFP-GE-Z information.

Introduction

This document provides information about Gigabit Interface Converter (GBIC) modules and small form-factor (SFP) GBIC modules on the Cisco 7200VXR routers, the Cisco 7201 router, the Cisco 7301 router, the Cisco 7304 router, the Cisco 7401ASR router, the Cisco 7500 series routers, the Cisco 7600 series routers, the Cisco 10008 router, the Cisco 12000 series routers, and the Cisco uBR7246VXR cable



Americas Headquarters:
Cisco Systems, Inc., 170 West Tasman Drive, San Jose, CA 95134-1706 USA

© 2007 Cisco Systems, Inc. All rights reserved.

router and Cisco uBR10012 cable router. The GBIC modules and SFP modules are input/output devices that plug into a Gigabit Ethernet (GE) port, linking the port with a 1000BASE-X fiber-optic network. The devices are used on Cisco platforms that have Gigabit Ethernet interfaces.

Also see the documentation that shipped with the GBIC module or SFP module or the installation guide for your router, I/O controller, processor engine, or port adapter.

Contents

This document contains the following sections:

- [Related Documentation, page 2](#)
- [GBIC Module and SFP Module Overview, page 4](#)
- [Cisco 1000BASE-T SFP Modules, page 9](#)
- [CWDM GBIC Module and SFP Module Description and Information, page 9](#)
- [Mode-Conditioning Patch Cord Description, page 13](#)
- [Installation Prerequisites, page 15](#)
- [Installing and Removing the GBIC Module or SFP Module, page 16](#)
- [Installing a GBIC Module, page 17](#)
- [Installing an SFP Module, page 18](#)
- [Installing the GBIC Module or SFP Module Interface Cables, page 20](#)
- [Fiber-Optic Cleaning Information, page 22](#)
- [Obtaining Documentation and Submitting a Service Request, page 23](#)

Related Documentation

The Cisco IOS software running on your router contains extensive features and functionality, which are documented online and in the following resources:

- Cisco IOS software configuration documentation contains Cisco IOS software configuration information and support. See the modular configuration and modular command reference publications in the set that corresponds to the software release installed on your Cisco hardware. Access these documents at:

<http://www.cisco.com/cisco/web/psa/default.html?mode=prod>

For hardware installation and maintenance information, refer to the following documents:

- Cisco 7200 series routers:
[Cisco 7200 Series Routers Documentation Roadmap](#)
- Cisco 7201 router:
[Cisco 7201 Router Documentation Roadmap](#)
- Cisco 7301 router:
[Cisco 7301 Internet Router Documentation Roadmap](#)
- Cisco 7304 router
[Cisco 7304 Internet Router Documentation Roadmap](#)
- Cisco 7401ASR router:

- [*Cisco 7401ASR Router Documentation Roadmap*](#)
- Cisco 7500 series routers:
 - [*Cisco 7500 Series Routers Documentation Roadmap*](#)
- Cisco 7600 series routers:
 - [*Cisco 7600 Series Internet Router Installation Guide*](#)
 - [*Cisco 7609 Internet Router Installation Guide*](#)
- Cisco 10000 ESR routers:
 - [*Cisco 10000 Series Routers Line Card Hardware Installation Guide*](#)
- Cisco 12000 series routers
 - [*Cisco 12000 Series Internet Router Install and Upgrade Guides*](#)
- Cisco uBR7246VXR cable router and Cisco uBR10012 cable router:
 - [*Cisco uBR10012 Universal Broadband Router Hardware Installation Guide*](#)
 - [*Cisco uBR7246VXR Universal Broadband Router Quick Start Guide*](#)
- For international agency compliance, safety, and statutory information for WAN interfaces:
 - [*Site Preparation and Safety Guide*](#)
 - [*Regulatory Compliance and Safety Information for the Cisco 7200 Series Routers*](#)
 - [*Regulatory Compliance and Safety Information for the Cisco 7301 Internet Router*](#)
 - [*Regulatory Compliance and Safety Information for Cisco 7304 Internet Router*](#)
 - [*Regulatory Compliance and Safety Information for the Cisco 7401ASR Internet Router*](#)
 - [*Regulatory Compliance and Safety Information for Cisco 7500 Series Routers*](#)
 - [*Regulatory Compliance and Safety Information for the Cisco 7600 Series Routers*](#)
 - [*Regulatory Compliance and Safety Information for Cisco 12000 Series Internet Routers*](#)
- To view Cisco documentation or obtain general information about the documentation, refer to the “Obtaining Documentation and Submitting a Service Request” section on page 23.

GBIC Module and SFP Module Overview

The following topics are in this section:

- [SFP and GBIC Short Wavelength Modules, page 7](#)
- [SFP and GBIC Long Wavelength Modules, page 7](#)
- [SFP and GBIC Extended Wavelength Modules, page 7](#)
- [GBIC Module and SFP Module Cabling and Connection Equipment, page 8](#)

The GBIC module and SFP module are input/output (I/O) devices that plug into a Gigabit Ethernet port, linking the port with a 1000BASE-X fiber-optic network. A GBIC module is shown in [Figure 1](#), and an SFP module in [Figure 2](#).

Note

Other GBIC modules and SFP modules exist for technologies other than Gigabit Ethernet. However, the information in this document is for GBIC modules and SFP modules that plug in to only Gigabit Ethernet ports.

Figure 1 GBIC Module

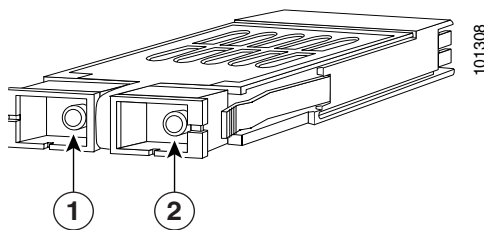

1	Receiver (RX)	2	Transmitter (TX)
----------	---------------	----------	------------------

Figure 2 SFP Module

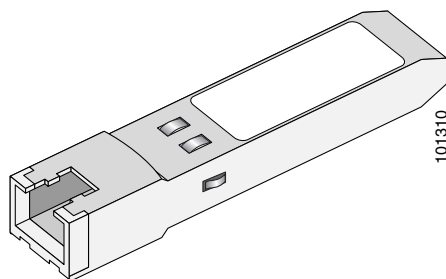

The GBIC module and SFP module have a receiver port (RX) and a transmitter port (TX) that make up one optical interface.

The following tables provide information and specifications:

- [Table 1, “GBIC Module and SFP Module Options”](#)
- [Table 2, “GBIC Module and SFP Module Transmit Power, Receive Power, and Power Budget”](#)
- [Table 3, “SFP-GE-F, SFP-GE-L, SFP-GE-S, and SFP-GE-Z Module Transmit Power, Receive Power, and Power Budget”](#)
- [Table 4, “GBIC Module Specifications”](#)
- [Table 5, “SFP Module Specifications”](#)

Table 1 GBIC Module and SFP Module Options

GBIC Module Product Number	SFP Module Product Number	GBIC Module or SFP Module	Description
WS-G5484	GLC-SX-MM	Short wavelength (1000BASE-SX)	Contains a Class 1 laser of 850 nm for 1000BASE-SX (short wavelength) applications.
WS-G5486	GLC-LH-SM	Long wavelength/long haul (1000BASE-LX/LH)	Contains a Class 1 laser of 1300 nm for 1000BASE-LX/LH (long wavelength) applications.
WS-G5487	GLC-ZX-SM	Extended distance (1000BASE-ZX)	Contains a Class 1 laser of 1550 nm for 1000BASE-ZX (extended wavelength) applications.

Table 2 GBIC Module and SFP Module Transmit Power, Receive Power, and Power Budget

GBIC Module and SFP Module	Transmit Power		Receive Power		Power Budget
	Minimum	Maximum	Minimum	Maximum	
WS-G5484 and GLC-SX-MM	-9.5 dB ¹	-3 dB ¹	-17 dB	0 dB	7.5 dB ²
WS-G5486 and GLC-LH-SM	-9.5 dB ³ -11.5 dB ⁴	-3 dB ⁵	-20 dB	-3 dB	8.5 dB ⁶ and 10.5 dB ⁷
WS-G5487 and GLC-ZX-SM	0 dB	5.2 dB	-24 dB	-3 dB	-24 dB

1. For fiber types 50/125 μm , NA = 0.20 fiber and 62.5/125 μm , NA = 0.275 fiber.

2. For fiber types 50/125 μm MMF and 62.5/125 μm MMF.

3. For fiber types 9/125 μm SMF.

4. For fiber types 62.5/125 μm MMF and 50/125 μm MMF.

5. For fiber types 9/125 μm SMF, 62.5/125 μm MMF, and 50/125 μm MMF.

6. For fiber types 50/125 μm MMF and 62.5/125 μm MMF.

7. For fiber type 10 μm SMF.



Note

For more information on Link budget, refer to the following Cisco document:

http://www.cisco.com/en/US/prod/collateral/modules/ps5455/ps6577/product_data_sheet0900aecd8033f885.html

Table 3 provides power budget information for the SFP-GE-F, SFP-GE-L, SFP-GE-S, and SFP-GE-Z modules.

Table 3 SFP-GE-F, SFP-GE-L, SFP-GE-S, and SFP-GE-Z Module Transmit Power, Receive Power, and Power Budget

SFP Modules	Transmit Power		Receive Power		Power Budget
	Minimum	Maximum	Minimum	Maximum	
SFP-GE-F= For 50/125 cabling For 62.5/125 cabling	-23.5 -20	-14 -14	-33.5 -33.5	-11.8 -11.8	10 dB 13.5 dB
SFP-GE-L	-9.5 dB ¹ -11.5 dB ²	-3 dB ³	-20 dB	-3 dB	8.5 dB ⁴ and 10.5 dB ⁵
SFP-GE-S	-9.5 dB ⁶	-3 dB	-17 dB	0 dB	7.5 dB ⁷
SFP-GE-Z	0 dB	5 dB	-23 dB	0 dB	-24 dB

1. For fiber types 9/125 mm SMF.
2. For fiber types 62.5/125 mm MMF and 50/125 mm MMF.
3. For fiber types 9/125 mm SMF, 62.5/125 mm MMF, and 50/125 mm MMF.
4. For fiber types 50/125 mm MMF and 62.5/125 mm MMF.
5. For fiber type 10 mm SMF.
6. For fiber types 50/125 mm, NA = 0.20 fiber and 62.5/125 mm, NA = 0.275 fiber.
7. For fiber types 50/125 mm MMF and 62.5/125 mm MMF.

Table 4 lists the GBIC module physical specifications and Table 5 lists the SFP module physical specifications.

Table 4 GBIC Module Specifications

Specification	Description
Dimensions (H x W x D)	0.39 in. x 1.18 in. x 2.56 in. (1 cm x 3 cm x 6.5 cm)
Connectors	Multimode fiber-optic: SC-type connector Single-mode fiber-optic: SC-type connector
Wavelength	WS-G5484: 850 nm WS-G5486: 1300 nm WS-G5487: 1550 nm
Cabling distance (maximum)	WS-G5484: 1804 feet (550 m) WS-G5486: 6.2 miles (10 km) WS-G5487: 43.5 to 62.1 miles (70 to 100 km)

Table 5 SFP Module Specifications

Specification	Description
Dimensions (H x W x D)	0.33 in x 0.53 in x 2.22 in (8.5 mm x 13.4 mm x 56.5 mm)
Connectors	Multimode fiber-optic: LC-type connector Single-mode fiber-optic: LC-type connector

Table 5 SFP Module Specifications (continued)

Specification	Description
Wavelength	GLC-SX-MM: 850 nm GLC-LH-SM: 1300 nm GLC-ZX-SM: 1550 nm GLC-GE-FX: 1300 nm
Cabling distance (maximum)	GLC-SX-MM: 1804 feet (550 m) GLC-LH-SM: 6.2 miles (10 km) GLC-ZX-SM: 43.5 to 62.1 miles (70 to 100 km) GLC-GE-FX: 1.2428 miles (2 km)

SFP and GBIC Short Wavelength Modules

The 1000BASE-SX (short wavelength) GBIC module operates on standard multimode fiber-optic link spans of up to 1804 feet (550 m). (See [Table 6](#).)

The 100BASE-FX SFP module is a hot-swappable device that plugs into a Gigabit Ethernet SFP port. It provides full-duplex 100-Mbps connectivity over multimode fiber (MMF) infrastructures. The 100BASE-FX SFP operates on ordinary MMF optical link spans of up to 1.2428 miles (2 km) in length.

SFP and GBIC Long Wavelength Modules

The 1000BASE-LX/LH (long wavelength/long haul) GBIC module interfaces fully comply with the IEEE 802.3z 1000BASE-LX standard. However, their higher optical quality allows them to reach 6.2 miles (10 km) over single-mode fiber (SMF) versus the 3.1 miles (5 km) specified in the standard.

SFP and GBIC Extended Wavelength Modules

The 1000BASE-ZX (extended wavelength) GBIC module operates on ordinary single-mode fiber-optic link spans of up to 43.5 miles (70 km). Link spans of up to 62.1 miles (100 km) are possible using premium single-mode fiber or dispersion-shifted single-mode fiber (premium single-mode fiber has a lower attenuation per unit length than ordinary single-mode fiber; dispersion-shifted single-mode fiber has both lower attenuation and less dispersion).

The 1000BASE-ZX GBIC module must be coupled to single-mode fiber-optic cable, which is the type of cable typically used in long-haul telecommunications applications. The 1000BASE-ZX GBIC module will not operate correctly when coupled to multimode fiber, and it is not intended to be used in environments where multimode fiber is frequently used (for example, building backbones, or horizontal cabling).

The 1000BASE-ZX GBIC module is intended to be used as a Physical Medium Dependent (PMD) component for Gigabit Ethernet interfaces found on various switch and router products. It operates at a signaling rate of 1250 Mbaud, transmitting and receiving 8B/10B encoded data.

When shorter lengths of single-mode fiber are used, it may be necessary to insert an in-line optical attenuator in the link to avoid overloading the receiver.

- Insert a 10-dB in-line optical attenuator between the fiber-optic cable plant and the receiving port on the 1000BASE-ZX GBIC module at each end of the link whenever the fiber-optic cable span is less than 15.5 miles (25 km).

- Insert a 5-dB in-line optical attenuator between the fiber-optic cable plant and the receiving port on the 1000BASE-ZX GBIC module at each end of the link whenever the fiber-optic cable span is equal to or greater than 15.5 miles (25 km) but less than 31 miles (50 km).

GBIC Module and SFP Module Cabling and Connection Equipment

The GBIC module port is a 1000-Mbps optical interface in the form of an SC-type duplex port (see Figure 1) that supports IEEE 802.3z interfaces compliant with the 1000BASE-X standard.

Table 6 provides cabling specifications for the GBIC modules and SFP modules that you install in Gigabit Ethernet devices. Note that all GBIC module ports have SC-type connectors and all SFP ports have LC-type connectors.

The minimum cable distance for the WS-G5484 or GLC-SX-MM and WS-G5486 or GLC-LH-SM (multimode fiber [MMF] and single-mode fiber [SMF]) is 6.5 feet (2 m), and the minimum link distance for the WS-G5487 or GLC-ZX-SM is 6.2 miles (10 km) with an 8-dB attenuator installed at each end of the link. Without attenuators, the minimum link distance for the WS-G5487 or GLC-ZX-SM is 24.9 miles (40 km).

Table 6 GBIC and SFP Module Port Cabling Specifications

GBIC Module	SFP Modules	Wavelength (nm)	Fiber Type	Core Size (micron)	Modal Bandwidth (MHz-km)	Maximum Cable Distance
WS-G5484 or GLC-SX-MM	SFP-GE-S or GLC-SX-MM	850	MMF ¹	62.5	160	722 ft (220 m)
				62.5	200	902 ft (275 m)
				50.0	400	1640 ft (500 m)
				50.0	500	1804 ft (550 m)
WS-G5486 or GLC-LH-SM	SFP-GE-L or GLC-LH-SM	1300	MMF ² and SMF	62.5	500	1804 ft (550 m)
				50.0	400	1804 ft (550 m)
				50.0	500	1804 ft (550 m)
				9/10	—	6.2 miles (10 km)
WS-G5487 ³ or GLC-ZX-SM	SFP-GE-Z or GLC-ZX-SM	1550	SMF	9/10	—	43.5 miles (70 km)
			SMF ⁴	8	—	62.1 miles (100 km)
GLC-GE-100FX	SFP-GE-F	1270 (min), 1300 (avg), 1380 (max)	MMF	62.5 62.5 50.0 50.0	500	1.4 miles (6562 ft)

1. Multimode fiber (MMF) only.
2. A mode-conditioning patch cord is required.
When using the WS-G5486 or GLC-LH-SM with 62.5-micron diameter MMF, you must install a mode-conditioning patch cord between the GBIC module or SFP module and the MMF cable on both the transmit and the receive ends of the link when link distances are greater than 984 ft (300 m). We do not recommend using the WS-G5486 or GLC-LH-SM and MMF with no patch cord for very short link distance (tens of meters). The result could be an elevated bit error rate (BER).

3. You can have a maximum of 12 1000BASE-ZX GBIC modules or SFP modules per system to comply with EN55022 Class B and 24 1000BASE-ZX GBIC modules or SFP modules per system to comply with FCC Class A regulations.
4. Dispersion-shifted single-mode fiber-optic cable.

**Note**

The 1000BASE-ZX GBIC module and SFP modules provide an optical power budget of 21.5 dB. You should measure your cable plant with an optical loss test set to verify that the optical loss of the cable plant (including connectors and splices) is less than or equal to 21.5 dB. The optical loss measurement must be performed with a 1550-nm light source.

Cisco 1000BASE-T SFP Modules

The 1000BASE-T (GLC-T) SFP module is compliant with IEEE 802.3:2000 and plugs into a standard Gigabit Ethernet SFP module port. It operates on standard Category 5 wiring and has an RJ-45 connector.

See your router installation and configuration guide to determine which routers support the GLC-T SFP module.

Table 7 *GLC-T SFP Module Specifications*

Specification	Description
Dimensions (H x W x D)	.055 in. x .054 in. x 2.8 in (14.0 mm. x 13.7 mm. x 71.1 mm)
Cabling Distance (maximum)	328 feet (100 m)
Power consumption	1.1W
Product number	GLC-T=

CWDM GBIC Module and SFP Module Description and Information

Coarse Wavelength-Division Multiplexing (CWDM) GBIC modules and Coarse Wavelength-Division Multiplexing (CWDM) SFP modules are supported on a variety of Cisco products. For more information, see the [Cisco CWDM GBIC Compatibility Matrix](#) and the [Cisco Coarse Wavelength-Division Multiplexing SFP Compatibility Matrix](#).

Figure 3 CWDM GBIC Module

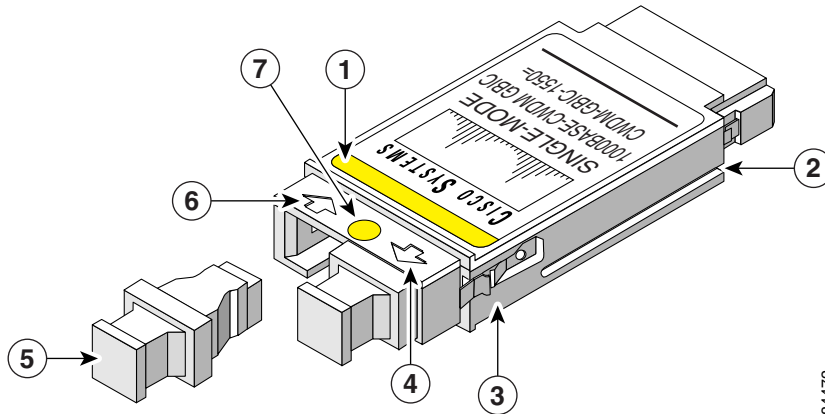

84472

1	Color band on label	5	Optical bore dust plug
2	Alignment groove	6	Receive optical bore
3	Spring clip	7	Color dot
4	Transmit optical bore		

Figure 4 CWDM SFP Module

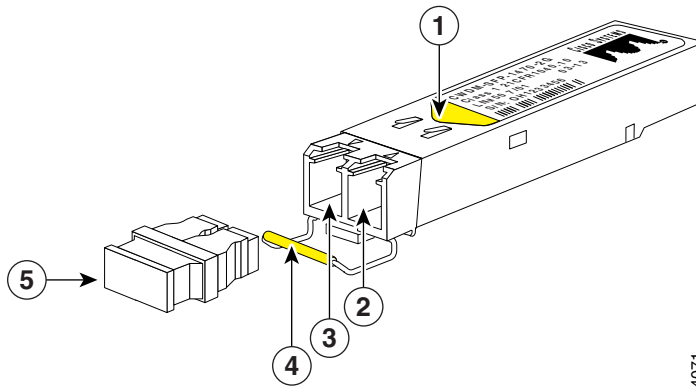

94071

1	Color arrow on label	4	Color coded bale clasp
2	Receive optical bore	5	Optical bore dust plug
3	Transmit optical bore		

The Cisco CWDM GBIC module and SFP modules enables the transport of up to eight channels (Gigabit Ethernet over single-mode fiber strands. (They also support the transport of up to eight channels [Fiber Channel] over single-mode strands, although Fiber Channel is not discussed in this document.) Cisco CWDM GBIC modules have SC-type connectors, and Cisco CWDM SFP modules have LC-type connectors. They are compatible with 1000BASE-X standard as specified in IEEE 802.3z. The Cisco CWDM GBUC modules and SFP modules are passive and require no power nor configuration. The Cisco CWDM modules support online insertion and removal (OIR).

See your router installation and configuration guide for the Cisco CWDM GBIC modules and SFP modules supported on your router.

The following tables provide specification information:

- [Table 8, “CWDM GBIC Module Options”](#)
- [Table 9, “CWDM GBIC Module Electrical Power Interface Information”](#)
- [Table 10, “CWDM GBIC Module Optical Parameters”](#)
- [Table 11, “CWDM SFP Module Options”](#)
- [Table 12, “CWDM SFP Module Electrical Power Interface Information”](#)
- [Table 13, “CWDM SFP Module Optical Parameters”](#)

Table 8 CWDM GBIC Module Options

Product Number	Description	Color
CWDM-GBIC-1470=	Cisco 1000BASE-CWDM GBIC 1470 nm	Gray
CWDM-GBIC-1490=	Cisco 1000BASE-CWDM GBIC 1490 nm	Violet
CWDM-GBIC-1510=	Cisco 1000BASE-CWDM GBIC 1510 nm	Blue
CWDM-GBIC-1530=	Cisco 1000BASE-CWDM GBIC 1530 nm	Green
CWDM-GBIC-1550=	Cisco 1000BASE-CWDM GBIC 1550 nm	Yellow
CWDM-GBIC-1570=	Cisco 1000BASE-CWDM GBIC 1570 nm	Orange
CWDM-GBIC-1590=	Cisco 1000BASE-CWDM GBIC 1590 nm	Red
CWDM-GBIC-1610=	Cisco 1000BASE-CWDM GBIC 1610 nm	Brown

Table 9 CWDM GBIC Module Electrical Power Interface Information

Parameter	Symbol	Minimum	Typical	Maximum	Units
Supply Current	I_s	–	280	350.0	mA
Maximum voltage	V_{max}	–	–	6.0	V
Surge current	I_{Surge}	–	–	400.0	mA
Input voltage	V_{cc}	4.75	5	5.25	V

Table 10 CWDM GBIC Module Optical Parameters

Parameter	Symbol	Minimum	Typical	Maximum	Units	Notes/Conditions
Transmitter center wavelength	λ_C	(x-4)	–	(x+7)	nm	Available center wavelengths are 1470, 1490, 1510, 1530, 1550, 1570, 1590, and 1610 nm
Side-mode suppression ratio	SMSR	30	–	–	db	–
Transmitter optical output power	P_{out}	+1.0	+3.0	+5.0	dB	Average power coupled into single-mode fiber

Table 10 CWDM GBIC Module Optical Parameters (continued)

Parameter	Symbol	Minimum	Typical	Maximum	Units	Notes/Conditions
Receiver optical input power (BER <10 ⁻¹² with PRBS 2-7-1)	P _{in}	-29.0	-33.0	-7.0	dB	@ 1.25 Gbps, 140°F (60°C) case temperature
Optical input wavelength	λ _{in}	1450	–	1620.0	nm	–
Transmitter extinction ratio	OMI	9	–	–	dB	–
Dispersion penalty at 100 km	–	–	–	3.0	dB	@ 1.25 Gbps

Parameters are specified over temperature and at end of life unless otherwise noted.

When shorter distances of single-mode fiber are used, it may be necessary to insert an in-line optical attenuator in the link to avoid overloading the receiver.

Table 11 CWDM SFP Module Options

Product Number	Description	Color
CWDM-SFP-1470=	Cisco 1000BASE-CWDM SFP 1470 nm	Gray
CWDM-SFP-1490=	Cisco 1000BASE-CWDM SFP 1490 nm	Violet
CWDM-SFP-1510=	Cisco 1000BASE-CWDM SFP 1510 nm	Blue
CWDM-SFP-1530=	Cisco 1000BASE-CWDM SFP 1530 nm	Green
CWDM-SFP-1550=	Cisco 1000BASE-CWDM SFP 1550 nm	Yellow
CWDM-SFP-1570=	Cisco 1000BASE-CWDM SFP 1570 nm	Orange
CWDM-SFP-1590=	Cisco 1000BASE-CWDM SFP 1590 nm	Red
CWDM-SFP-1610=	Cisco 1000BASE-CWDM SFP 1610 nm	Brown

Table 12 CWDM SFP Module Electrical Power Interface Information

Parameter	Symbol	Minimum	Typical	Maximum	Units
Supply current	I _s	–	220	300	mA
Surge current	I _{Surge}	–	–	+30	mA
Input voltage	V _{max}	3.1	3.3	3.6	V

Table 13 CWDM SFP Module Optical Parameters

Parameter	Symbol	Minimum	Typical	Maximum	Units	Notes/Conditions
Transmitter center wavelength	λ_C	(x-4)	–	(x+7)	nm	Available center wavelengths are 1470, 1490, 1510, 1530, 1550, 1570, 1590, and 1610 nm
Side-mode suppression ratio	SMSR	30	–	–	dB	–
Transmitter optical output power	P_{out}	0	–	5.0	dB	Average power coupled into single-mode fiber
Receiver optical input power (BER <10 ⁻¹² with PRBS 2-7-1)	P_{in}	-28	–	-7.0	dB	@ 2.12 Gbps, 140° F (60° C) case temperature
Receiver optical input power (BER <10 ⁻¹² with PRBS 2-7-1)	P_{in}	-29	–	-7.0	dB	@ 1.25 Gbps, 140° F (60° C) case temperature
Receiver optical input wavelength	λ_{in}	1450	–	1620	nm	–
Transmitter extinction ratio	OMI	9	–	–	dB	–
Dispersion penalty at 100 km	–	–	–	3	dB	@ 2.12 Gbps
Dispersion penalty at 100 km	–	–	–	2	dB	@ 1.25 Gbps

Parameters are specified over-temperature and at end-of-life unless otherwise noted.

When shorter distances of single-mode fiber are used, it may be necessary to insert an in-line optical attenuator in the link to avoid overloading the receiver.

Mode-Conditioning Patch Cord Description

A mode-conditioning patch cord can be used with the WS-G5486 to allow reliable laser transmission between the single-mode laser source on the GBIC module and a multimode optical fiber cable.

When an unconditioned laser source designed for operation on single-mode optical fiber is directly coupled to a multimode optical fiber cable, an effect known as *differential mode delay* (DMD) might result in a degradation of the modal bandwidth of the optical fiber cable.

This degradation results in a decrease in the link span (the distance between a transmitter and a receiver) that can be supported reliably. The effect of DMD can be overcome by conditioning the launch characteristics of a laser source. A practical means of performing this conditioning is to use a device called a mode-conditioning patch cord.

A mode-conditioning patch cord is an optical fiber cable assembly that consists of a pair of optical fibers terminated with connector hardware. Specifically, the mode-conditioning patch cord is composed of a single-mode optical fiber permanently coupled off-center (see Offset in Figure 5 and Figure 6) to a graded-index multimode optical fiber. Figure 5 and Figure 6 show a diagram of the mode-conditioning patch cord assembly.

Figure 5 Mode Conditioning Patch Cord Assembly with GBIC Module-Type Connector

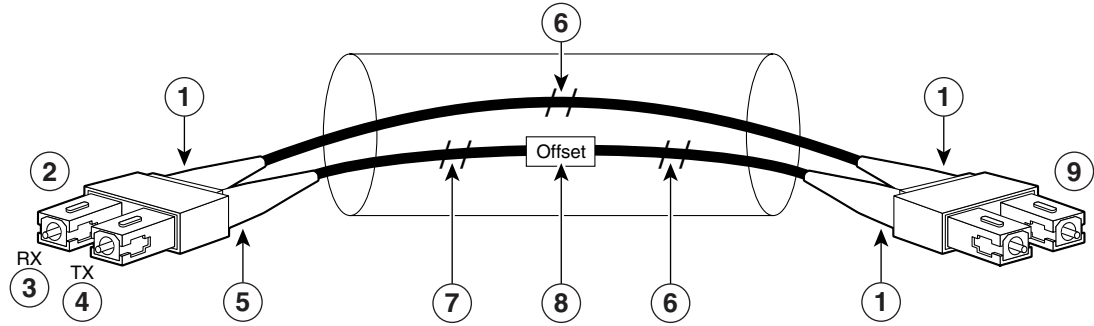

1	Beige color identifier	6	Multimode fiber
2	To GE interface	7	Single-mode fiber
3	RX	8	Offset
4	TX	9	To cable plant
5	Blue color identifier		

Figure 6 Mode Conditioning Patch Cord Assembly with SFP Module-Type Connector

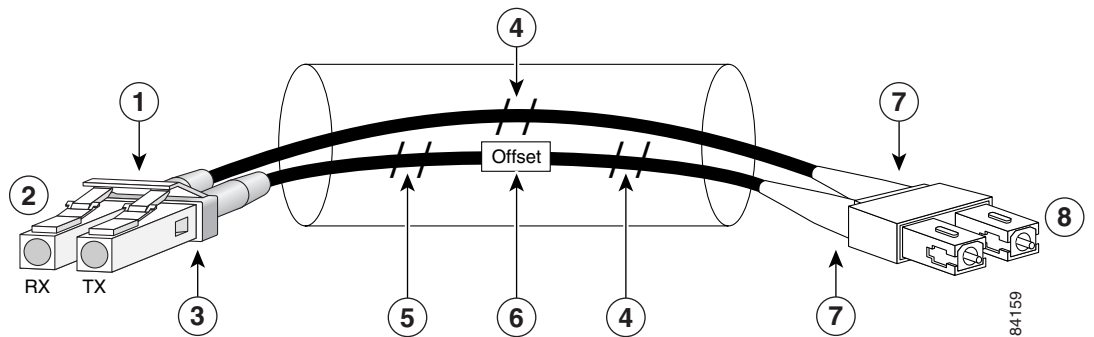

1	Gray color identifier	5	Single-mode bar
2	To GE interface	6	Offset
3	Blue color identifier	7	Beige color identifier
4	Multimode bar	8	To cable plant

The mode-conditioning patch cord assembly is composed of duplex optical fibers, including a single-mode-to-multimode offset launch fiber connected to the transmitter, and a second conventional graded-index multimode optical fiber connected to the receiver. The use of a plug-to-plug patch cord maximizes the power budget of multimode 1000BASE-LX and 1000BASE-LH links.

**Note**

The mode-conditioning patch cord is required to comply with IEEE standards. The IEEE found that link distances could not be met with certain types of fiber-optic cable cores. The solution is to launch light from the laser at a precise offset from the center, which is accomplished by using the mode-conditioning patch cord. At the output end of the patch cord, the GBIC-LX/LH is compliant with the IEEE 802.3z standard for 1000BASE-LX.

Installation Prerequisites

This section describes safety and compliance guidelines you should observe before you install the GBIC module or SFP module in your Gigabit Ethernet device.

Safety Guidelines

Before handling a GBIC module or SFP module, observe the following guidelines:

- GBIC modules and SFP modules are static-sensitive. To prevent electrostatic discharge (ESD) damage, follow your normal board- and component-handling procedures.
- GBIC modules and SFP modules are dust-sensitive. When storing a GBIC module or SFP module or when a fiber-optic cable is not plugged in, always keep plugs in the GBIC module or SFP module optical bores. (See plug in [Figure 7](#).)
- The most common source of contaminants in the optical bores is debris picked up on the ferrules of the optical connectors. Use an alcohol swab or lint-free absorbent wipes to clean the ferrules of the optical connector.

**Warning**

Class 1 laser product.

**Warning**

Class 1 LED product.

**Warning**

Because invisible laser radiation may be emitted from the aperture of the port when no fiber cable is connected, avoid exposure to laser radiation and do not stare into open apertures.

FCC Class A Compliance

This equipment has been tested and found to comply with the limits for a Class A digital device, pursuant to part 15 of the FCC rules. These limits are designed to provide reasonable protection against harmful interference when the equipment is operated in a commercial environment. This equipment generates, uses, and can radiate radio-frequency energy and, if not installed and used in accordance with the instruction manual, may cause harmful interference to radio communications. Operation of this equipment in a residential area is likely to cause harmful interference, in which case users will be required to correct the interference at their own expense.

You can determine whether your equipment is causing interference by turning it off. If the interference stops, it was probably caused by the Cisco equipment or one of its peripheral devices. If the equipment causes interference to radio or television reception, try to correct the interference by using one or more of the following measures:

- Turn the television or radio antenna until the interference stops.
- Move the equipment to one side or the other of the television or radio.
- Move the equipment farther away from the television or radio.
- Plug the equipment into an outlet that is on a different circuit from the television or radio. (That is, make certain the equipment and the television or radio are on circuits controlled by different circuit breakers or fuses.)

**Note**

This product has been designed to meet these requirements. Modifications to this product that are not authorized by Cisco, could void the various approvals and negate your authority to operate the product.

Installing and Removing the GBIC Module or SFP Module

GBIC modules or SFP modules might ship already installed in your device, or they might arrive packaged separately. This section describes how to install or remove the GBIC module or SFP module from your Gigabit Ethernet interface.

**Note**

You can install and remove GBIC modules or SFP modules with power on to the system; however, we strongly recommend that you do *not* install or remove the GBIC module or SFP module with optical fiber cables attached to it. Disconnect all cables before removing or installing a GBIC module or SFP module.

**Caution**

To prevent system problems, do not use GBIC modules or SFP modules from third-party vendors. Use only GBIC modules or SFP modules supplied by Cisco.

Removing a GBIC Module or SFP Module

**Warning**

Ultimate disposal of this product should be handled according to all national laws and regulations.

**Note**

You can install and remove GBIC modules or SFP modules with power on to the system; however, we strongly recommend that you do *not* install or remove the GBIC module or SFP module with optical fiber cables attached to it. Disconnect all cables before removing or installing a GBIC module or SFP module.

To remove a GBIC module, perform the following steps:

Step 1

Disconnect the network fiber cable from the GBIC module SC-type connector or SFP module LC-type connector.

- Step 2** Release the GBIC module or SFP module.
- Release the GBIC module from the slot by simultaneously squeezing the two plastic tabs (one on each side of the GBIC module).
 - Release the SFP module. See [Figure 11](#) for the various types of latches that may be on your SFP module.
- Step 3** Slide the GBIC module or SFP module out of the slot.

This completes the procedure to remove a GBIC module or SFP module from the Gigabit Ethernet interface.

Installing a GBIC Module

Use the following procedure to install a GBIC module:



Note A horizontally oriented slot is shown for illustration purposes. Some chassis may have vertically oriented slots.

- Step 1** Attach an ESD-preventive wrist strap between you and an unpainted chassis surface.
- Step 2** Locate the alignment groove on the GBIC module (see the enlargement in [Figure 7](#) and [Figure 8](#)).
- Step 3** Align the groove on the GBIC module with the interface opening (see [Figure 7](#) and [Figure 8](#)).



Note GBIC modules are keyed to prevent incorrect insertion.

Figure 7 Inserting a GBIC Module with Alignment Groove on Top—Cisco 7301 Gigabit Ethernet Interface Shown

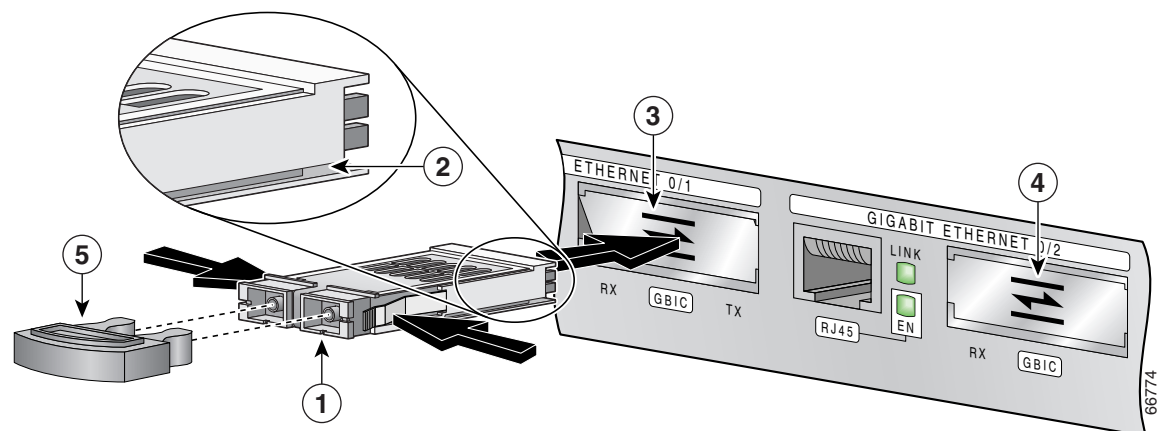

1	GBIC module	4	GBIC module port 0/2
2	Alignment groove	5	Plug
3	GBIC module port 0/1		

**Note**

Some horizontally oriented devices accept the GBIC module with the alignment groove on top. Other devices accept the GBIC module with the alignment groove on the bottom. (See [Figure 8](#).) If the GBIC module does not go into the interface slot, ensure that the alignment groove and the interface opening are lined up and, if necessary, flip the GBIC module over (rotate it 180 degrees) and try inserting it again.

Figure 8 *Inserting a GBIC Module with Alignment Groove on the Bottom*

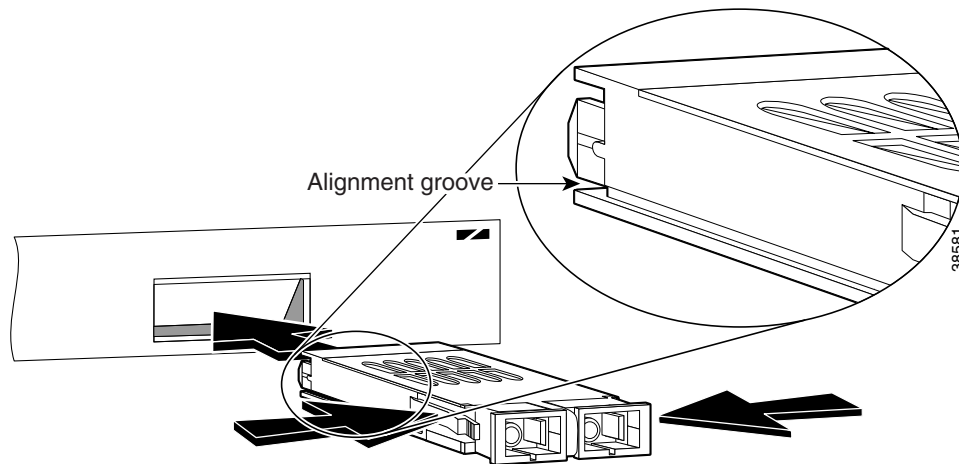

- Step 4** Carefully slide the GBIC module into the GBIC slot and seat it. When installed, the GBIC module input/output panel should be flush with the face of the interface panel.
- Step 5** Attach the network interface fiber-optic cable, as described in the [“Installing the GBIC Module or SFP Module Interface Cables”](#) section on page 20, remove the plug from the GBIC module optical bores, and save the plug for future use.

This completes the procedure for installing a GBIC module.

Installing an SFP Module

SFP modules ordered with the system come installed in the system. Optical fiber cables are commercially available; they are not available from Cisco.

Figure 9 Optical SFP Module and Copper SFP Modules

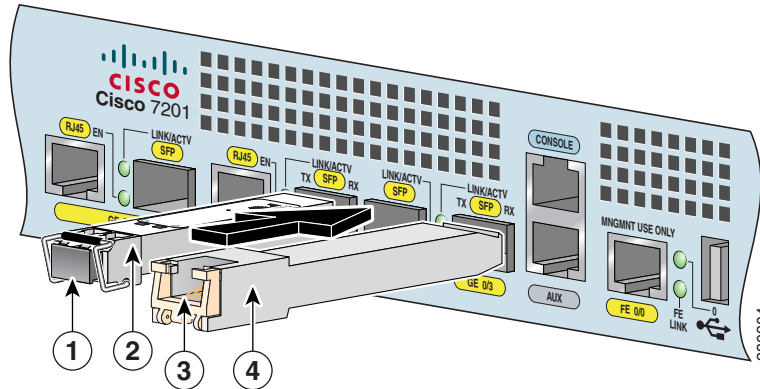

1	Optical SFP module plug	3	Copper SFP module RJ-45 connector
2	Optical SFP module	4	Copper SFP module

Figure 10 Installing an SFP Module

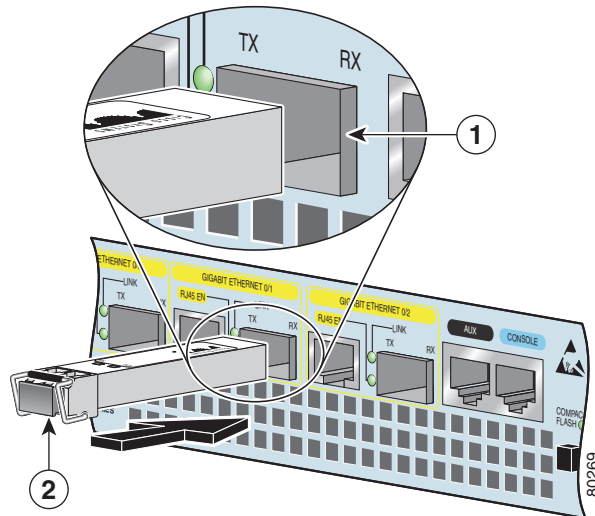

1	SFP port	2	Latch beneath plug
----------	----------	----------	--------------------

- Step 1** Turn the SFP module so the latch is on the bottom. The SFP module is keyed so that it cannot be inserted incorrectly.
- Step 2** Insert the SFP module into an SFP port. Repeat Step 2 if you are inserting a second or third SFP module.
- Step 3** Do not remove the SFP module plugs until you are ready to install the cables.

Figure 11 SFP Module Showing a Variety of Latches

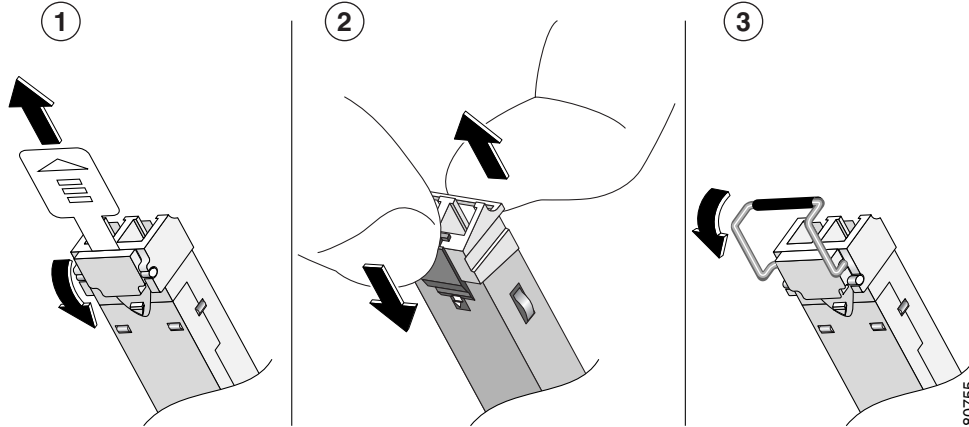

1	Sliding latch	3	Swing latch
2	Swing and slide latch		



Note

Different manufacturers have different types of latching mechanisms for Gigabit Ethernet SFP modules. There is no correlation of the type of latch to the model (such as SX or LH) or technology type (such as Gigabit Ethernet) of SFP modules. See the label for the SFP technology type and model. The SFP modules use LC-type connectors.

Installing the GBIC Module or SFP Module Interface Cables

This section describes how to attach the interface cables to the GBIC module or SFP module.



Note

Optical fiber cables are commercially available; they are not available from Cisco Systems.

Attaching Multimode and Single-Mode Optical Fiber Cables

Attach the appropriate optical fiber cable directly to the SC-type receptacle on the GBIC module or the LC-type connector on the SFP module. You can use either simplex or duplex connectors for most devices. (See [Figure 12](#).)

- For simplex connectors, two cables are required, one cable for transmit (TX) and a second cable for receive (RX).
- For duplex connectors, only one cable that has both TX and RX connectors is required.



Caution

If you plan to use a GBIC-LX/LH or GLC-LH-SM at distances greater than 984.25 feet (300 meters) over 50/125-micron or 62.5/125-micron multimode fiber, to prevent data transmission problems you must use the mode-conditioning patch cord. (See the [“Attaching the Mode-Conditioning Patch Cord”](#) section on page 22.)

Figure 12 GBIC Module Port Connections

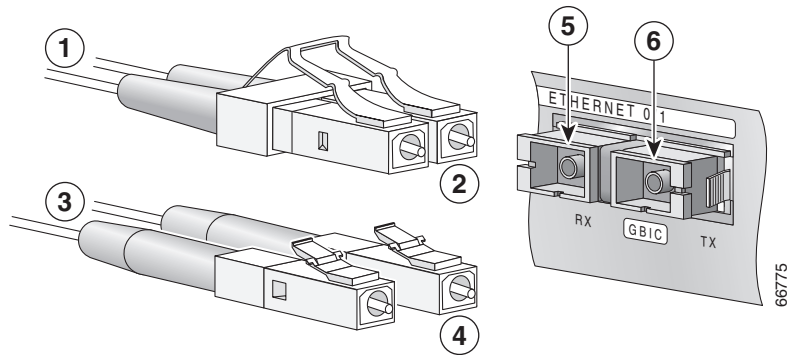

1	To external 1000BASE-X network	5	RX
2	1 duplex connector (RX and TX)	6	TX
3	To external 1000BASE-X network	7	GBIC module port
4	2 simplex connectors	8	RJ-45 port



Note

You can not run GBIC signals (laser light) in both the directions in a single glass fibre. The duplex glass fibre consists of two glass fibre cores that transmit light in opposite directions. In case of simplex connection for GBIC port, you need two glass fibres (each transmitting in opposite direction).

Figure 13 SFP Module Port Connections

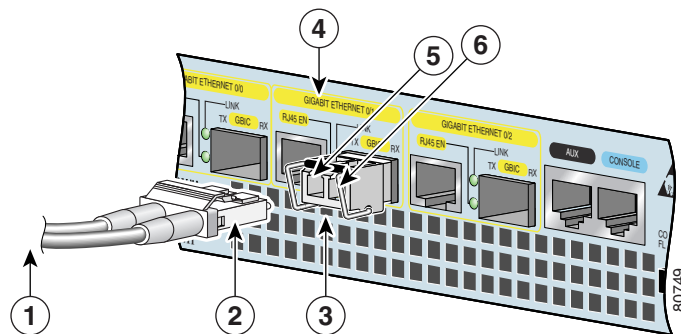

1	To external 1000BASE-X network	4	SFP (GE) port 0/1
2	1 duplex connector (RX and TX)	5	TX
3	SFP module	6	RX

Figure 14 RJ-45 Port and Copper SFP RJ-45 Gigabit Ethernet Port Cabling

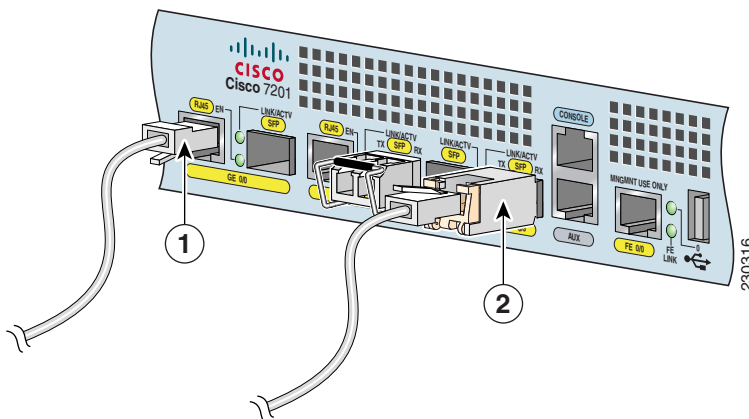

1	RJ-45 connector	2	Copper SFP module RJ-45 connector
---	-----------------	---	-----------------------------------

Attaching the Mode-Conditioning Patch Cord

Perform the following steps to attach the mode-conditioning patch cord:

- Step 1** Attach the patch cord to the SC-type receptacle on the GBIC module (Figure 5) or the LC-type connector on the SFP module (Figure 6).
- Step 2** Attach the network ends of your patch cord to the appropriate 1000BASE-X equipment in your building cable plant.



Note Ensure that you connect the TX and RX ports on one end of the patch cord to the RX and TX ports (respectively) on the other end. Connect TX to RX and RX to TX.

If you are attaching cables from CWDM GBIC modules or SFP modules to the Cisco optical add-drop (OADM) modules, see the documentation for the OADM modules.

This completes the procedure for attaching a mode-conditioning patch cord.

Fiber-Optic Cleaning Information

For information about cleaning fiber-optic cable connectors and receptacles, see the [Inspection and Cleaning Procedures for Fiber-Optic Connections](#) document. It provides detailed illustrations and photos of procedures and equipment required to properly clean fiber-optic connections. Also see the [Compressed Air Cleaning Issues for Fiber-Optic Connections](#) document.

Obtaining Documentation and Submitting a Service Request

For information on obtaining documentation, submitting a service request, and gathering additional information, see the monthly *What's New in Cisco Product Documentation*, which also lists all new and revised Cisco technical documentation, at:

<http://www.cisco.com/en/US/docs/general/whatsnew/whatsnew.html>

Subscribe to the *What's New in Cisco Product Documentation* as a Really Simple Syndication (RSS) feed and set content to be delivered directly to your desktop using a reader application. The RSS feeds are a free service and Cisco currently supports RSS Version 2.0.

Cisco and the Cisco Logo are trademarks of Cisco Systems, Inc. and/or its affiliates in the U.S. and other countries. A listing of Cisco's trademarks can be found at www.cisco.com/go/trademarks. Third party trademarks mentioned are the property of their respective owners. The use of the word partner does not imply a partnership relationship between Cisco and any other company. (1005R)

Copyright © 2009 Cisco Systems, Inc. All rights reserved.

