

How to Configure Windows 98, Windows 2000, Windows NT, and Windows XP Professional Dial-up Networking by a Null-Modem Cable

Document ID: 14946

Introduction

Prerequisites

Requirements

Components Used

Conventions

Windows 98 Dial-up Networking by a Null-Modem Cable

Windows 2000 Dial-up Networking by a Null-Modem Cable

Windows NT Dial-up Networking by a Null-Modem Cable

Windows XP Professional Dial-up Networking using Null-Modem Cable

Cable Information

Scenario 1

Scenario 2

Scenario 3

Scenario 4

mdmcsico.inf File Contents

Cisco Access Server Configuration

Verify

Troubleshoot

Related Information

Introduction

This document contains information on how to set up Microsoft Windows 98, Windows 2000, Windows NT, and Windows XP Professional Dial-up Networking to connect to the Cisco Access Server asynchronous (async) port using a null-modem cable with PPP.

Prerequisites

Requirements

There are no specific requirements for this document.

Components Used

The information in this document is based on the software and hardware versions:

- Cisco 3600 Router running Cisco IOS® Software Release 12.1(20)
- Microsoft Windows 98
- Microsoft Windows 2000, 5.00.2195, Service Pack 2
- Microsoft Windows NT, Version 4.0, Build 1381, Service Pack 6
- Microsoft Windows XP Professional

The information in this document was created from the devices in a specific lab environment. All of the

devices used in this document started with a cleared (default) configuration. If your network is live, make sure that you understand the potential impact of any command.

Conventions

For more information on document conventions, see the Cisco Technical Tips Conventions.

Windows 98 Dial-up Networking by a Null-Modem Cable

Follow the steps below to configure Dial-up Networking.

1. Download a null-modem INF file.

Native Windows 98 Dial-up Networking software does not allow for a null-modem connection, so you need to download a null-modem INF file and install it as a null-modem device before beginning the configuration.

Note: PPP is supported only on Cisco auxiliary (AUX) and async ports. The maximum speed of Cisco AUX and async ports is 115200. (In some hardware, such as the Cisco 2500 series, the maximum AUX port speed is 38400.)

Follow these steps to create your own mdmcisco.inf file:

- a. Create a new file named mdmcisco.inf using Microsoft Notepad.
 - b. Copy the contents found below in mdmcisco.inf File Contents into the file you created. Be sure that you do not add or remove any data or characters and that your text editor does not add carriage returns to wide lines.
 - c. Save the file.
2. Install the mdmcisco.inf file by following these steps:

- a. Double-click on the **My Computer** icon on your desktop.
- b. Double-click on the **Control Panel** icon.
- c. Double-click on the **Modems** icon.

The Modems Properties window is displayed.

- d. Click **Add**.
 - e. Check the **Don't detect my modem; I will select it from a list** option, and click **Next**.
 - f. Click **Have Disk**.
 - g. Enter the path to the file mdmcisco.inf, and click **OK**.
 - h. Select **Generic Null Modem**, and click **Next**.
 - i. Select the appropriate communications (COM) port that is cabled directly to the Cisco async port, and click **Next**.
 - j. Click **Finish** to complete installation of a generic null modem.
3. Configure Windows 98 Dial-up Networking by following these steps:

- a. From the Start menu, choose **Programs > Accessories > Communication > Dial-up Networking**.
- b. Double-click the **Make New Connection** icon in the Dial-up Networking window.
- c. Type a name for this connection in the Make New Connection window, for example "Null-Connection".
- d. Choose the **Generic Null Modem** option from the pull-down menu in the Make New Connection window.
- e. Click **Configure**.

- f. Under the General tab, select from the pull-down menu the proper COM port that is cabled directly to the Access Server.
- g. Select the maximum speed (for example, **115200**) from the pull-down menu.

Note: The speed you select must match the maximum speed of the router async port. The maximum speed for a standard async port is 115200. The maximum speed for an AUX port is 38400 in some cases.

- h. Under the Connection tab, the default **8N1** should remain selected.
- i. Under Advanced Settings, the default **Flowcontrol Hardware** should remain selected.
- j. Under the Options tab, verify that neither of the two **Bring up terminal window before/after dialing** options is selected.
- k. Click **OK**.

This takes you back to the Make New Connection window.

- l. Click **Next**.
 - m. Enter any number as a telephone number (for example, *1234*). Leave the area code blank and the country code as United States of America.
 - n. Click **Next**.
 - o. Click **Finish**.
4. Use the new connection, as follows:

- a. From the Start menu, choose **Programs > Accessories > Communication > Dial-up Networking**.
- b. Click the **Null-Connection** icon to highlight it.
- c. From the File menu, choose **Properties**.

The Null-Connection window is displayed.

- d. Under the General tab, verify that the information is correct.
 - e. Under the Server Types tab, verify that **PPP, Internet, Windows NT server, Windows 98** is selected under Type of Dial-up Server.
 - f. Verify that the **TCP/IP** option is selected under Allowed Network Protocols.
 - g. Click **TCP/IP Settings**.
 - h. In the window that is displayed, verify that the **Server Assigned IP Address** and **Server Assigned Name Server Address** radio buttons are selected.
 - i. Check **Use IP Header Compression** and **Use Default Gateway on Remote Network** to verify that they are properly selected.
 - j. Click **OK**.
 - k. When you are returned to the Null-Connection window, choose the **General** tab.
 - l. Click **Configure**.
 - m. In the window that is displayed, choose the **Options** tab.
 - n. Verify that neither of the **Bring up terminal window before/after dialing** options is selected.
 - o. Click **OK**.
 - p. In the Null-Connection window, click **OK** to complete the configuration.
5. Connect to the Access Server by following these steps:

- a. Double-click the **Null-Connection** icon.
- b. In the window that is displayed, enter the *username* that was configured for you on the Access Server.
- c. Enter the *password* that was configured for you on the Access Server.

The username and password are authenticated.

- d. Wait to connect to the Access Server.
6. Run the application of your choice, such as Netscape, Internet Explorer, Ping, or Telnet.

Windows 2000 Dial-up Networking by a Null-Modem Cable

The steps for using Windows 2000 Dial-up Networking with a null-modem cable is similar to the Windows 98 configuration described in the Windows 98 Dial-up Networking by a Null-Modem Cable section of this document.

1. Obtain or create the mdmcsisco.inf file (refer to Step 1 of the Windows 98 Dial-up Networking by a Null-Modem Cable section of this document).
2. To install the mdmcsisco.inf file, add a modem as follows:
 - a. Choose **Start > Settings > Control Panel > Phone and Modem Options**.
 - b. Follow the Windows 98 procedures described in Step 2 of the Windows 98 Dial-up Networking by a Null-Modem Cable section of this document.
 - c. When the Digital Signature Not Found window appears, click **Yes** to continue with the installation.
 - d. You should find the Generic Null Modem installed on the COM port you selected during installation.
 - e. Click **Generic Null Modem** to highlight it.
 - f. Choose **Properties**.
 - g. Set the port speed to match the speed of the async port configuration.
 - h. Click **OK** twice to finish the installation.
3. Create a new dial-up connection as follows:
 - a. Choose **Start > Settings > Network and Dial-up Connections > Make New Connection**.
 - b. In the Welcome to Network Wizard Connection window, click **Next**.
 - c. Select **Dial-up to Private Network**, and click **Next**.
 - d. Select only **Generic Null Modem** from the Select a Device window.

If any other device is checked, uncheck it, and click **Next**.
 - e. Enter any number as the phone number (for example, *12345*), and click **Next**.
 - f. Choose **For All Users**, and click **Next**.
 - g. Type a name for this connection, such as "Null-Connection", and click **Finish**.
4. Use the new Null-Connection by following these steps:
 - a. Choose **Start > Settings > Network and Dial-up Connections > Null-Connection**.
 - b. Enter the username and password that is valid on the Access Server.
 - c. The dial number (dummy number 12345) should appear. Click **Dial** to connect.
5. Upon successful PPP connection to the Access Server, issue the **winnipcfg** command on Windows 2000 to determine the IP address assigned by the Access Server to the PPP dial-up client adapter.

Note: Ensure that the speed set under Generic Null Modem Properties is the same speed of the Access Server async port. The Null-Connection default properties may be used as set. However, if the properties have been changed to use a static IP address or Domain Name System (DNS) IP address, then be sure to configure the Access Server so that it does not assign an IP address to the PPP client.

Windows NT Dial-up Networking by a Null-Modem Cable

The steps for using Windows NT Dial-up Networking with a null-modem cable are similar to the Windows 98 configuration described in the Windows 98 Dial-up Networking by a Null-Modem Cable section and the Windows 2000 configuration described in the Windows 2000 Dial-up Networking by a Null-Modem Cable section of this document. The following steps show the setup for Windows NT:

1. Obtain or create the mdmcisco.inf file (refer to Step 1 of the Windows 98 Dial-up Networking by a Null-Modem Cable section of this document).
2. Install the mdmcisco.inf file, as follows:
 - a. Choose **Start > Settings > Control Panel > Modems**.
 - b. The Install New Modem window appears.

Check **Don't detect my modem; I will select it from a list**.
 - c. Click **Next**.
 - d. Click **Have Disk**.
 - e. Enter the path to the file mdmcisco.inf.
 - f. Click **OK**.
 - g. Select **Generic Null Modem**, and click **Next**.
 - h. Select the appropriate COM port that is cabled directly to the async port, and click **Next**.
 - i. Click **Finish** to complete installation of a generic null modem.
3. Configure Dial-up Networking, as follows:
 - a. In the Modem Properties window, choose the **General** tab.
 - b. Select **Properties of Generic Null Modem**.
 - c. Verify that the maximum speed of the COM port is set to match the speed configured under the async port on the Access Server side.
 - d. Under the Connection tab, the default **8N1** should remain selected.
 - e. Click **Close**.
 - f. The Modem Setup window appears. It asks if Dial-up Networking needs to be configured.

Click **Yes**.
 - g. The Remote Access Setup window appears.

Click **Add**.
 - h. In the Add RAS Device window, choose **Generic Null Modem** from the pull-down menu.
 - i. Click **OK**.
 - j. Click **Configure**.
 - k. In the Configure Port Usage window, be sure that the port usage radio button **Dial Out Only** is selected.
 - l. Click **OK** to return to the Remote Access Setup window.
 - m. In the Remote Access Setup window, click **Continue**.
 - n. The Restart Your Computer Now option appears.

Click **Yes**.
4. Use the generic null modem by Dial-up Networking, following these steps:
 - a. Choose **My Computer > Dial-up Networking**.
 - b. In the Dial-up Networking window, Null-Connection appears in the Phone Book Entry to Dial box, and the dial number (a dummy number, such as 12345) appears in the Phone Number Preview box.

Click **Dial**.
 - c. Enter a username and password that is valid on the Access Server.

You do not need to enter any domain information.
 - d. Click **OK**.
5. If all cabling and settings are correct, you are successfully connected to the Access Server. Issue **ipconfig** from the DOS command to determine the IP address assigned to the Windows NT client from the Access Server.

Windows XP Professional Dial-up Networking using Null-Modem Cable

The steps for using Windows XP Dial-up Networking with a null-modem cable are similar to the Windows 98 configuration described in the Windows 98 Dial-up Networking by a Null-Modem Cable section of this document.

1. Obtain or create the mdmcsisco.inf file (refer to Step 1 of the Windows 98 Dial-up Networking by a Null-Modem Cable section of this document).
2. To install the mdmcsisco.inf file, add a modem as follows:

- a. Choose **Start > Control Panel > Printers and Other Hardware > Phone and Modem Options**.
- b. Follow the Windows 98 procedures described in Step 2 of the Windows 98 Dial-up Networking by a Null-Modem Cable section of this document.
- c. When a message appears alerting you that the software was not able to pass Windows logo testing, select **Continue Anyway**, and click **Finish**.

You should find the Generic Null Modem installed on the COM port you selected during installation.

- d. Click **Generic Null Modem** to highlight it.
 - e. Choose **Properties**.
 - f. Under the Modem tab, set the port speed to match the speed of the async port configuration.
 - g. Click **OK** twice to finish the installation.
3. Create a new dial-up connection as follows:

- a. Choose **Start > Control Panel > Network and Internet Connections > Create a connection to the network at your workplace**.
- b. Select **Dial-up Connection**, and click **Next**.
- c. Type a name for this connection, such as "Null-Connection", and click **Next**.
- d. Enter any number as the phone number (for example, *12345*), click **Next**, and then click **Finish**.
- e. Before using Null-Connection, ensure that Connect Using Modem Generic Null-Modem (COMx) has been installed in Properties.

To check for it, choose **Start > Connect To > Null-Connection > Properties**.

4. Use the Null-Connection by following these steps:

- a. Choose **Start > Connect To > Null-Connection**.
- b. Enter the username and password that is valid on the Access Server. (The PC serial port is directly connected to the Access Server by the null-modem cable.)
- c. The dial number (a dummy number, such as *12345*) appears. If it does not come up, enter a dummy number, and click **Dial to Connect**.

5. Upon successful PPP connection to the Access Server, issue the **ipconfig** command from the DOS prompt to determine the IP address assigned by the Access Server to the PPP dial-up client adapter.

Note: Ensure that the speed set under Generic Null Modem Properties is the same speed of the Access Server async port. The Null-Connection default properties may be used as set. However, if the properties have been changed to use a static IP address or DNS IP address, then be sure to configure the Access Server so that it does not assign an IP address to the PPP client.

Cable Information

The cabling scenarios below illustrate different ways of physically connecting to AUX ports and async ports.

Scenario 1

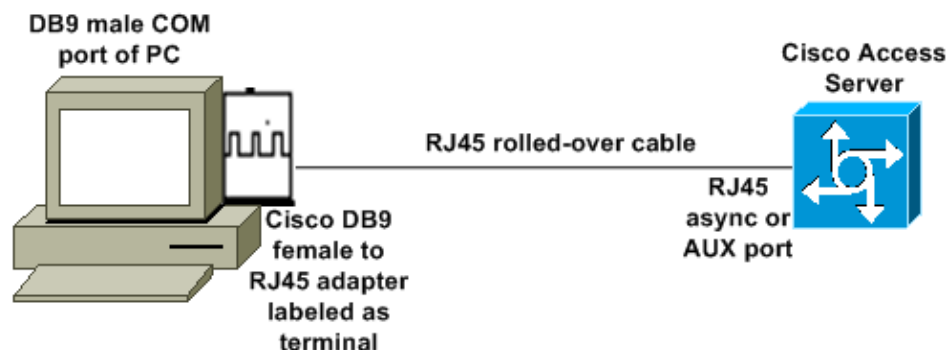

- The Cisco adapter (DB9 to RJ45) along with the Cisco rolled cable should act as a null-modem cable. That cabling should connect the PC and the Cisco Access Server (the Data Terminal Equipment [DTEs]) without the need for a null-modem cable.
- The Cisco DB9 to RJ45 terminal adapter part number is 74-0495-01.
- The Cisco rolled cable part number is CAB-500RJ.

Scenario 2

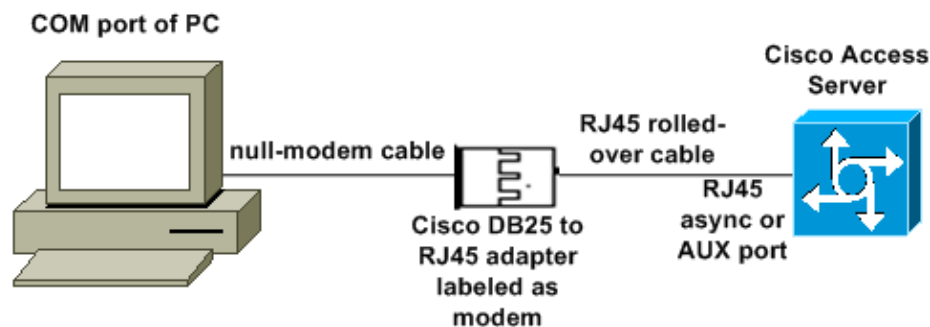

- The Cisco modem adapter part number is 74-0458-01 (revision A1).
- The Cisco rolled cable number is CAB-500RJ.

Scenario 3

If you are connecting to an async port (such as a Cisco 2509) that has an eight-port async cable, you can use the following scenario to connect one or more than one PC to it.

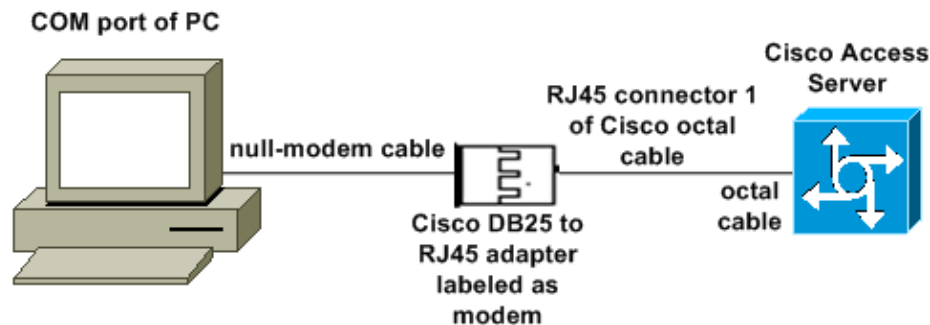

- The Cisco modem adapter part number is 74-0458-01 (revision A1).
- The Cisco octal cable part number is CAB-OCTAL-ASYNC=. This octal cable has eight RJ45 connectors.

Scenario 4

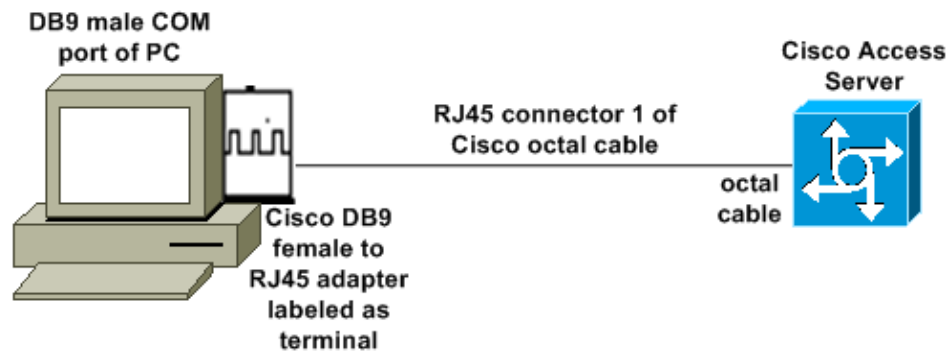

- The Cisco octal cable functions like an RJ45 rolled-over cable.

mdmcisco.inf File Contents

You can use the file contents below to create your own mdmcisco.inf file, or locate the file at Download mdmcbx.inf .

```
;=====start of text for mdmcisco.inf =====
```

```
[Version]
Signature="$CHICAGO$"
Class=Modem
ClassGUID={4D36E96D-E325-11CE-BFC1-08002BE10318}
Provider=%MC%
LayoutFile=LAYOUT.INF

[Manufacturer]
%Man% = Null

[Null]
%MC00% = MC00, RAS-SERIAL
%MC01% = MC01, RAS-PARALLEL
%MC02% = MC02, RAS-GENERIC

[MC00]
AddReg=All, Common, MC00Reg, 115200, EXTERNAL

[MC01]
AddReg=All, Common, MC00Reg, PARALLEL

[MC02]
AddReg=All, Common, MC02Reg, 115200, EXTERNAL

[All]
HKR,,FriendlyDriver,,Unimodem.vxd
HKR,,DevLoader,,*VCOMM
HKR,,PortSubClass,1,02
HKR,,ConfigDialog,,modemui.dll
HKR,,EnumPropPages,, "modemui.dll,EnumPropPages"

[EXTERNAL]
HKR,, DeviceType, 1, 01
```

```

[PARALLEL]
HKR,, DeviceType, 1, 04
HKR,, Override,, Paralink.vxd
HKR,, DCB, 1, 1C,00,00,00, 00,00,06,00, 15,20,00,00, 00,00, 0a,00, 0a,00, 08, 00, 00, 11,
 13, 00, 00, 00
!--- Note: The line of code above is displayed over two lines due to space limitations.

[Common]
HKR, Answer, 1,, ""
HKR, Hangup, 1,, "Bye"
HKR, Hangup, 2,, "NoResponse"
HKR, Settings, DialSuffix,, ""

; DCB's - dwords and words are byte reversed
;
;                                     ByteSize
; (Number of bits/byte, 4-8)
!--- Note: The line of code above is displayed over two lines due to space limitations.
;
;                                     Parity
; (0-4=None,Odd,Even,Mark,Space)
!--- Note: The line of code above is displayed over two lines due to space limitations.
;
;                                     StopBits
; (0,1,2 = 1, 1.5, 2)
!--- Note: The line of code above is displayed over two lines due to space limitations.
;
; |DCBLength |BaudRate |Bit Mask |Rsvd |XonLim|XofLim| | | |Xon
; |Xof|Err|Eof|Evt
!--- Note: The line of code above is displayed over two lines due to space limitations.

[115200]
HKR,, DCB, 1, 1C,00,00,00, 00,c2,01,00, 15,20,00,00, 00,00, 0a,00, 0a,00, 08, 00, 00, 11,
 13, 00, 00, 00
!--- Note: The line of code above is displayed over two lines due to space limitations.

[MC00Reg] ; RAS Null-Modem
HKR, Init, 1,, "<cr>"
HKR, Init, 2,, "NoResponse"
HKR, Settings, Prefix,, ""
HKR, Settings, DialPrefix,, "CLIENT<cr>"
HKR, Settings, Terminator,, "<cr>"
HKR, Monitor, 1,, "None"
HKR, Answer, 1,, "CLIENTSERVER"
HKR, Answer, 2,, "NoResponse"
; Properties - dwords and words are byte reversed
;
; |Dial Options |InactivityTimeout |Speaker Mode
; |Max DTE Rate
!--- Note: The line of code above is displayed over two lines due to space limitations.
;
; |CallSetupFailTimeout |Speaker Volume
; |Modem Options
!--- Note: The line of code above is displayed over two lines due to space limitations.
;
; |Max DCE Rate
!--- Note: The line of code above is displayed over two lines due to space limitations.
HKR,, Properties, 1, 00,00,00,00, 00,00,00,00, 00,00,00,00, 00,00,00,00, 00,00,00,00,
 30,00,00,00, 00,c2,01,00, 00,c2,01,00
!--- Note: The line of code above is displayed over two lines due to space limitations.

HKR, Responses, "CLIENT", 1, 08, 00, 00, 00, 00, 00, 00,00,00,00 ; Server side -
the client is requesting a connection
HKR, Responses, "<h00>CLIENT", 1, 08, 00, 00, 00, 00, 00, 00, 00,00,00,00 ; Server side -

```

```

the client is requesting a connection
HKR, Responses, "CLIENTSERVER", 1, 02, 00, 00, 00, 00, 00, 00, 00, 00, 00, 00, 00 ; Client side -
the server has acknowledged and the connection is completed
!--- Note: The lines of code above are each displayed over two lines due to
!--- space limitations.

[MC02Reg] ; Null-Modem
HKR, Init, 1,, "<cr><cr>"
HKR, Init, 2,, "NoResponse"
HKR, Settings, Prefix,, ""
HKR, Settings, DialPrefix,, "HELLO<cr>"
HKR, Settings, Terminator,, "<cr>"
HKR, Monitor, 1,, "None"
HKR, Answer, 1,, "HELLO"
HKR, Answer, 2,, "NoResponse"
; Properties - dwords and words are byte reversed
;           |Dial Options           |InactivityTimeout           |Speaker Mode
|Max DTE Rate
!--- Note: The line of code above is displayed over two lines due to space limitations.

;           |CallSetupFailTimeout       |Speaker Volume
|Modem Options           |Max DCE Rate
!--- Note: The line of code above is displayed over two lines due to space limitations.

HKR,, Properties, 1, 00,00,00,00, 00,00,00,00, 00,00,00,00, 00,00,00,00, 00,00,00,00,
30,00,00,00, 00,c2,01,00, 00,c2,01,00
!--- Note: The line of code above is displayed over two lines due to space limitations.

HKR, Responses, "<h00>", 1, 02, 00, 00, 00, 00, 00, 00, 00, 00, 00, 00, 00 ; Accept any recvd data
as CONNECTED.
HKR, Responses, "<hff>", 1, 02, 00, 00, 00, 00, 00, 00, 00, 00, 00, 00, 00 ; Accept any recvd data
as CONNECTED.
HKR, Responses, "<cr>", 1, 02, 00, 00, 00, 00, 00, 00, 00, 00, 00, 00, 00 ; Accept any recvd data
as CONNECTED.
HKR, Responses, "<lf>", 1, 02, 00, 00, 00, 00, 00, 00, 00, 00, 00, 00, 00 ; Accept any recvd data
as CONNECTED.
HKR, Responses, "<cr><lf>", 1, 02, 00, 00, 00, 00, 00, 00, 00, 00, 00, 00, 00 ; Accept any recvd data
as CONNECTED.
!--- Note: The lines of code above are each displayed over two lines
!--- due to space limitations.

[Strings]
MC = "Mark Crossley"
Man = "(NULL Modem Types)"
MC00 = "RAS Serial Cable between 2 PCs"
MC01 = "RAS Parallel Cable between 2 PCs"
MC02 = "Generic NULL Modem"

;====end of text for MDMCISCO.INF=====

```

Cisco Access Server Configuration

To support Windows Dial-up Networking on the PPP client and terminal access (for example, with use of Windows HyperTerminal), put the Access Server async port in **async modem interactive**. Use known good cables and adapters to connect the PC running Microsoft Windows and the Access Server as shown in Scenario 1, Scenario 2, Scenario 3, or Scenario 4.

Note: Remember that the console port of the Access Server can not run PPP.

The tested working configuration, along with the debugs of the Access Server, are shown below:

```
!
version 12.1
service timestamps debug datetime msec
no service password-encryption
!
hostname 3640
!
username WinNT password 0 testing
!
async-bootp dns-server 192.168.1.1 192.168.2.2
async-bootp nbns-server 192.168.3.3 192.168.4.4
!
interface Async129

!--- Interface number corresponds to async line.
!--- In this case, aux port is line 129.

ip address 10.10.10.10 255.255.255.0
encapsulation ppp
async mode interactive
peer default ip address 10.10.10.11
no cdp enable

ppp authentication chap
!
line aux 0

!--- AUX port or any other async port.

password <removed>
login
modem InOut
transport input all
escape-character NONE
autoselect during-login
autoselect ppp
stopbits 1
speed 115200
flowcontrol hardware
!
3640# show debug
PPP:
  PPP authentication debugging is on
  PPP protocol negotiation debugging is on
3640#
3640#
*Mar  5 06:57:18.414: As129 LCP: I CONFREQ [Closed] id 0 len 23
*Mar  5 06:57:18.414: As129 LCP:   ACCM 0x00000000 (0x020600000000)
*Mar  5 06:57:18.414: As129 LCP:   MagicNumber 0x00004A4E (0x050600004A4E)
*Mar  5 06:57:18.414: As129 LCP:   PFC (0x0702)
*Mar  5 06:57:18.414: As129 LCP:   ACFC (0x0802)
*Mar  5 06:57:18.414: As129 LCP:   Callback 6 (0x0D0306)
*Mar  5 06:57:18.414: As129 LCP: Lower layer not up, Fast Starting
*Mar  5 06:57:18.414: As129 PPP: Treating connection as a dedicated line
*Mar  5 06:57:18.414: As129 PPP: Phase is ESTABLISHING, Active Open
*Mar  5 06:57:18.418: As129 LCP: O CONFREQ [Closed] id 9 len 25
*Mar  5 06:57:18.418: As129 LCP:   ACCM 0x000A0000 (0x0206000A0000)
*Mar  5 06:57:18.418: As129 LCP:   AuthProto CHAP (0x0305C22305)
*Mar  5 06:57:18.418: As129 LCP:   MagicNumber 0x16242193 (0x050616242193)
*Mar  5 06:57:18.418: As129 LCP:   PFC (0x0702)
*Mar  5 06:57:18.418: As129 LCP:   ACFC (0x0802)
*Mar  5 06:57:18.418: As129 LCP: O CONFREQ [REQsent] id 0 len 7
*Mar  5 06:57:18.418: As129 LCP:   Callback 6 (0x0D0306)
4d06h: %LINK-3-UPDOWN: Interface Async129, changed state to up
```

```

*Mar 5 06:57:18.430: As129 LCP: I CONFACK [REQsent] id 9 len 25
*Mar 5 06:57:18.430: As129 LCP: ACCM 0x000A0000 (0x0206000A0000)
*Mar 5 06:57:18.430: As129 LCP: AuthProto CHAP (0x0305C22305)
*Mar 5 06:57:18.430: As129 LCP: MagicNumber 0x16242193 (0x050616242193)
*Mar 5 06:57:18.430: As129 LCP: PFC (0x0702)
*Mar 5 06:57:18.430: As129 LCP: ACFC (0x0802)
*Mar 5 06:57:18.434: As129 LCP: I CONFREQ [ACKrcvd] id 1 len 20
*Mar 5 06:57:18.434: As129 LCP: ACCM 0x00000000 (0x020600000000)
*Mar 5 06:57:18.434: As129 LCP: MagicNumber 0x00004A4E (0x050600004A4E)
*Mar 5 06:57:18.434: As129 LCP: PFC (0x0702)
*Mar 5 06:57:18.434: As129 LCP: ACFC (0x0802)
*Mar 5 06:57:18.434: As129 LCP: O CONFACK [ACKrcvd] id 1 len 20
*Mar 5 06:57:18.434: As129 LCP: ACCM 0x00000000 (0x020600000000)
*Mar 5 06:57:18.434: As129 LCP: MagicNumber 0x00004A4E (0x050600004A4E)
*Mar 5 06:57:18.434: As129 LCP: PFC (0x0702)
*Mar 5 06:57:18.434: As129 LCP: ACFC (0x0802)
*Mar 5 06:57:18.434: As129 LCP: State is Open
*Mar 5 06:57:18.438: As129 PPP: Phase is AUTHENTICATING, by this end
*Mar 5 06:57:18.438: As129 CHAP: O CHALLENGE id 5 len 25 from "3640"
*Mar 5 06:57:18.446: As129 LCP: I IDENTIFY [Open] id 2 len 18 magic 0x00004A4E MSRASV4.00
*Mar 5 06:57:18.450: As129 LCP: I IDENTIFY [Open] id 3 len 25 magic 0x00004A4E
MSRAS-1-CA_SERVER
!--- Note: The line of output above is displayed over two lines due to space limitations.

*Mar 5 06:57:18.450: As129 CHAP: I RESPONSE id 5 len 26 from "WinNT"
*Mar 5 06:57:18.454: As129 CHAP: O SUCCESS id 5 len 4
*Mar 5 06:57:18.454: As129 PPP: Phase is UP
*Mar 5 06:57:18.454: As129 IPCP: O CONFREQ [Closed] id 5 len 10
*Mar 5 06:57:18.454: As129 IPCP: Address 10.10.10.10 (0x03060A0A0A0A)
*Mar 5 06:57:18.458: As129 CCP: I CONFREQ [Not negotiated] id 4 len 4
*Mar 5 06:57:18.458: As129 LCP: O PROTREJ [Open] id 10 len 10 protocol CCP
(0x80FD01040004)
!--- Note: The line of output above is displayed over two lines due to space limitations.

*Mar 5 06:57:18.462: As129 IPCP: I CONFREQ [REQsent] id 5 len 40
*Mar 5 06:57:18.462: As129 IPCP: CompressType VJ 15 slots CompressSlotID
(0x0206002D0F01)
!--- Note: The line of output above is displayed over two lines due to space limitations.

*Mar 5 06:57:18.462: As129 IPCP: Address 0.0.0.0 (0x030600000000)
*Mar 5 06:57:18.462: As129 IPCP: PrimaryDNS 0.0.0.0 (0x810600000000)
*Mar 5 06:57:18.462: As129 IPCP: PrimaryWINS 0.0.0.0 (0x820600000000)
*Mar 5 06:57:18.466: As129 IPCP: SecondaryDNS 0.0.0.0 (0x830600000000)
*Mar 5 06:57:18.466: As129 IPCP: SecondaryWINS 0.0.0.0 (0x840600000000)
*Mar 5 06:57:18.466: As129 IPCP: O CONFREQ [REQsent] id 5 len 10
*Mar 5 06:57:18.466: As129 IPCP: CompressType VJ 15 slots CompressSlotID
(0x0206002D0F01)
!--- Note: The line of output above is displayed over two lines due to space limitations.

*Mar 5 06:57:18.466: As129 IPCP: I CONFACK [REQsent] id 5 len 10
*Mar 5 06:57:18.466: As129 IPCP: Address 10.10.10.10 (0x03060A0A0A0A)
*Mar 5 06:57:18.474: As129 IPCP: I CONFREQ [ACKrcvd] id 6 len 34
*Mar 5 06:57:18.474: As129 IPCP: Address 0.0.0.0 (0x030600000000)
*Mar 5 06:57:18.474: As129 IPCP: PrimaryDNS 0.0.0.0 (0x810600000000)
*Mar 5 06:57:18.474: As129 IPCP: PrimaryWINS 0.0.0.0 (0x820600000000)
*Mar 5 06:57:18.474: As129 IPCP: SecondaryDNS 0.0.0.0 (0x830600000000)
*Mar 5 06:57:18.474: As129 IPCP: SecondaryWINS 0.0.0.0 (0x840600000000)
*Mar 5 06:57:18.474: As129 IPCP: O CONFNAK [ACKrcvd] id 6 len 34
*Mar 5 06:57:18.474: As129 IPCP: Address 10.10.10.11 (0x03060A0A0A0B)
*Mar 5 06:57:18.474: As129 IPCP: PrimaryDNS 192.168.1.1 (0x8106C0A80101)
*Mar 5 06:57:18.474: As129 IPCP: PrimaryWINS 192.168.3.3 (0x8206C0A80303)
*Mar 5 06:57:18.474: As129 IPCP: SecondaryDNS 192.168.2.2 (0x8306C0A80202)
*Mar 5 06:57:18.474: As129 IPCP: SecondaryWINS 192.168.4.4 (0x8406C0A80404)
*Mar 5 06:57:18.486: As129 IPCP: I CONFREQ [ACKrcvd] id 7 len 34
*Mar 5 06:57:18.486: As129 IPCP: Address 10.10.10.11 (0x03060A0A0A0B)
*Mar 5 06:57:18.486: As129 IPCP: PrimaryDNS 192.168.1.1 (0x8106C0A80101)

```

```
*Mar 5 06:57:18.486: As129 IPCP: PrimaryWINS 192.168.3.3 (0x8206C0A80303)
*Mar 5 06:57:18.486: As129 IPCP: SecondaryDNS 192.168.2.2 (0x8306C0A80202)
*Mar 5 06:57:18.486: As129 IPCP: SecondaryWINS 192.168.4.4 (0x8406C0A80404)
*Mar 5 06:57:18.486: As129 IPCP: O CONFACK [ACKrcvd] id 7 len 34
*Mar 5 06:57:18.486: As129 IPCP: Address 10.10.10.11 (0x03060A0A0A0B)
*Mar 5 06:57:18.486: As129 IPCP: PrimaryDNS 192.168.1.1 (0x8106C0A80101)
*Mar 5 06:57:18.486: As129 IPCP: PrimaryWINS 192.168.3.3 (0x8206C0A80303)
*Mar 5 06:57:18.486: As129 IPCP: SecondaryDNS 192.168.2.2 (0x8306C0A80202)
*Mar 5 06:57:18.486: As129 IPCP: SecondaryWINS 192.168.4.4 (0x8406C0A80404)
*Mar 5 06:57:18.486: As129 IPCP: State is Open
*Mar 5 06:57:18.490: As129 IPCP: Install route to 10.10.10.11
4d06h: %LINEPROTO-5-UPDOWN: Line protocol on Interface Async129, changed state to up
3640#
3640#
3640#ping 10.10.10.11

Type escape sequence to abort.
Sending 5, 100-byte ICMP Echos to 10.10.10.11, timeout is 2 seconds:
!!!!
Success rate is 100 percent (5/5), round-trip min/avg/max = 20/20/20 ms
3640#
```

Verify

There is currently no verification procedure available for this configuration.

Troubleshoot

There is currently no specific troubleshooting information available for this configuration.

Related Information

- [Tools and Utilities – Cisco Systems](#)
- [Universal Gateways and Access Servers Product Support](#)
- [Dial – Access Technology Support](#)
- [Technical Support & Documentation – Cisco Systems](#)

[Contacts & Feedback](#) | [Help](#) | [Site Map](#)

© 2008 – 2009 Cisco Systems, Inc. All rights reserved. [Terms & Conditions](#) | [Privacy Statement](#) | [Cookie Policy](#) | [Trademarks of Cisco Systems, Inc.](#)

Updated: Jan 29, 2008

Document ID: 14946
