



## Functional Description

---

This chapter provides a functional description of the Cisco ASR 9000 Series Router, Route Switch Processor (RSP) card, Route Processor (RP) card, Switch Fabric Controller (FC) card, Ethernet line cards, power and cooling systems, and subsystems such as management, configuration, alarms, and monitoring.

- [Router Operation, on page 1](#)
- [Route Switch Processor Card, on page 5](#)
- [Route Processor Card, on page 6](#)
- [Fabric Controller Card, on page 12](#)
- [Ethernet Line Cards, on page 12](#)
- [Modular Line Cards, on page 13](#)
- [Power System Functional Description, on page 14](#)
- [Cooling System Functional Description, on page 22](#)
- [System Management and Configuration, on page 39](#)
- [Online Diagnostics, on page 40](#)

## Router Operation

The ASR 9000 Series Routers are fully distributed routers that use a switch fabric to interconnect a series of chassis slots, each of which can hold one of several types of line cards. Each line card in the Cisco ASR 9000 Series has integrated I/O and forwarding engines, plus sufficient control plane resources to manage line card resources. Two slots in the chassis are reserved for RSP/RP cards to provide a single point of contact for chassis provisioning and management.

[Figure 1: Cisco ASR 9010 Router, Cisco ASR 9006 Router, Cisco ASR 9904 Router and Cisco ASR 9910 Router Platform Architecture, on page 2](#) shows the platform architecture of the Cisco ASR 9010 Router, Cisco ASR 9006 Router, Cisco ASR 9904 Router and Cisco ASR 9910 Router.

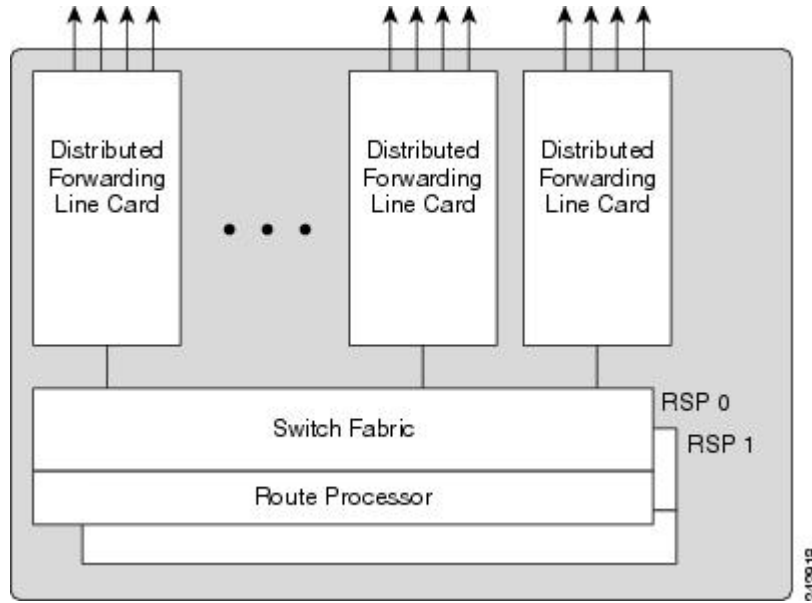
[Figure 2: Cisco ASR 9922 Router and Cisco ASR 9912 Router Platform Architecture, on page 2](#) show the platform architecture of the Cisco ASR 9922 Router and Cisco ASR 9912 Router.

[Figure 3: Major Components in the Cisco ASR 9000 Series Routers Line Cards, on page 3](#) shows the major components in the Cisco ASR 9000 Series line cards. [Figure 4: Additional System Components in the Cisco ASR 9000 Series Routers Line Cards, on page 4](#) shows additional components for the Cisco ASR 9000 Series line cards.

[Figure 5: Major System Components and Interconnections in the Cisco ASR 9922 Router, on page 5](#) shows the major system components and interconnections for the Cisco ASR 9922 Router. The switch fabric for the

Cisco ASR 9912 Router is the same except that the router supports up to 10 line cards. The switch fabric card (ASR-9912-SFC110) for the Cisco ASR 9912 Router, is the only FC that has a single fabric ASIC.

**Figure 1: Cisco ASR 9010 Router, Cisco ASR 9006 Router, Cisco ASR 9904 Router and Cisco ASR 9910 Router Platform Architecture**



**Figure 2: Cisco ASR 9922 Router and Cisco ASR 9912 Router Platform Architecture**

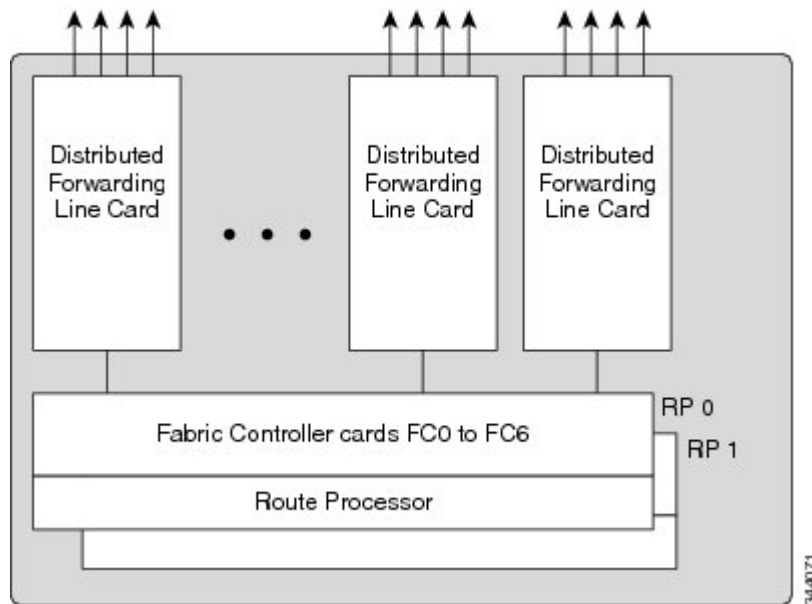
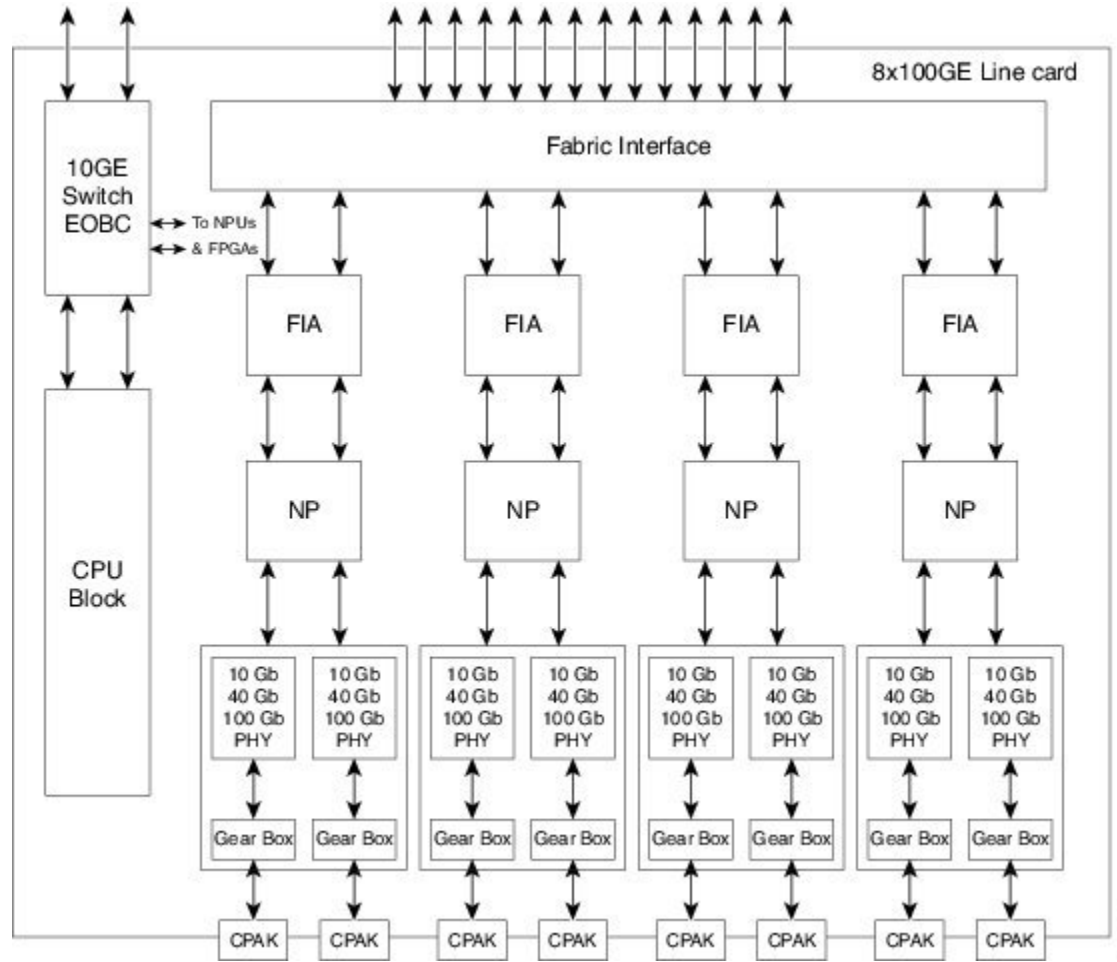


Figure 3: Major Components in the Cisco ASR 9000 Series Routers Line Cards



364-329

Figure 4: Additional System Components in the Cisco ASR 9000 Series Routers Line Cards

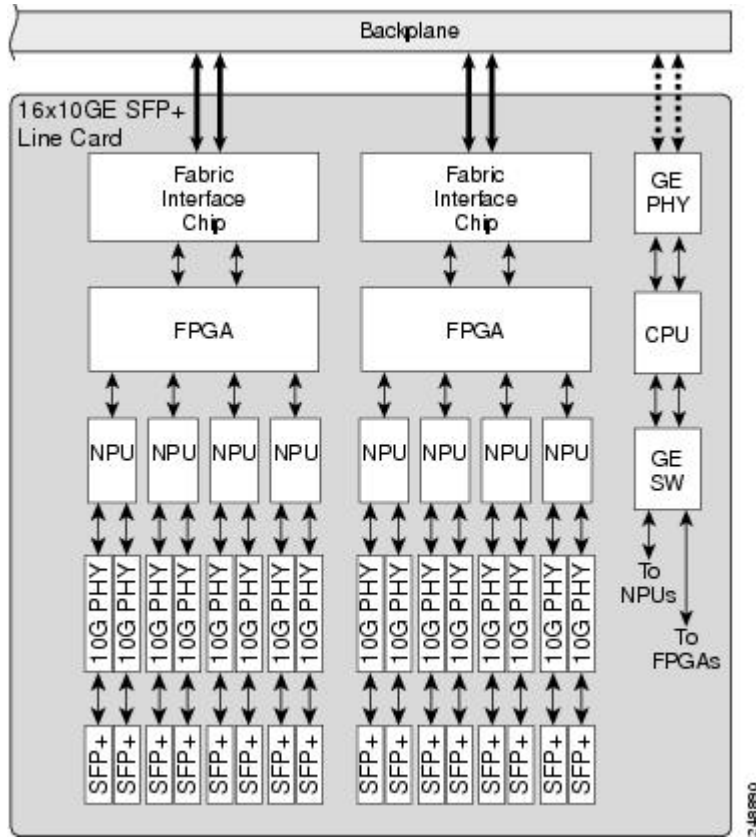
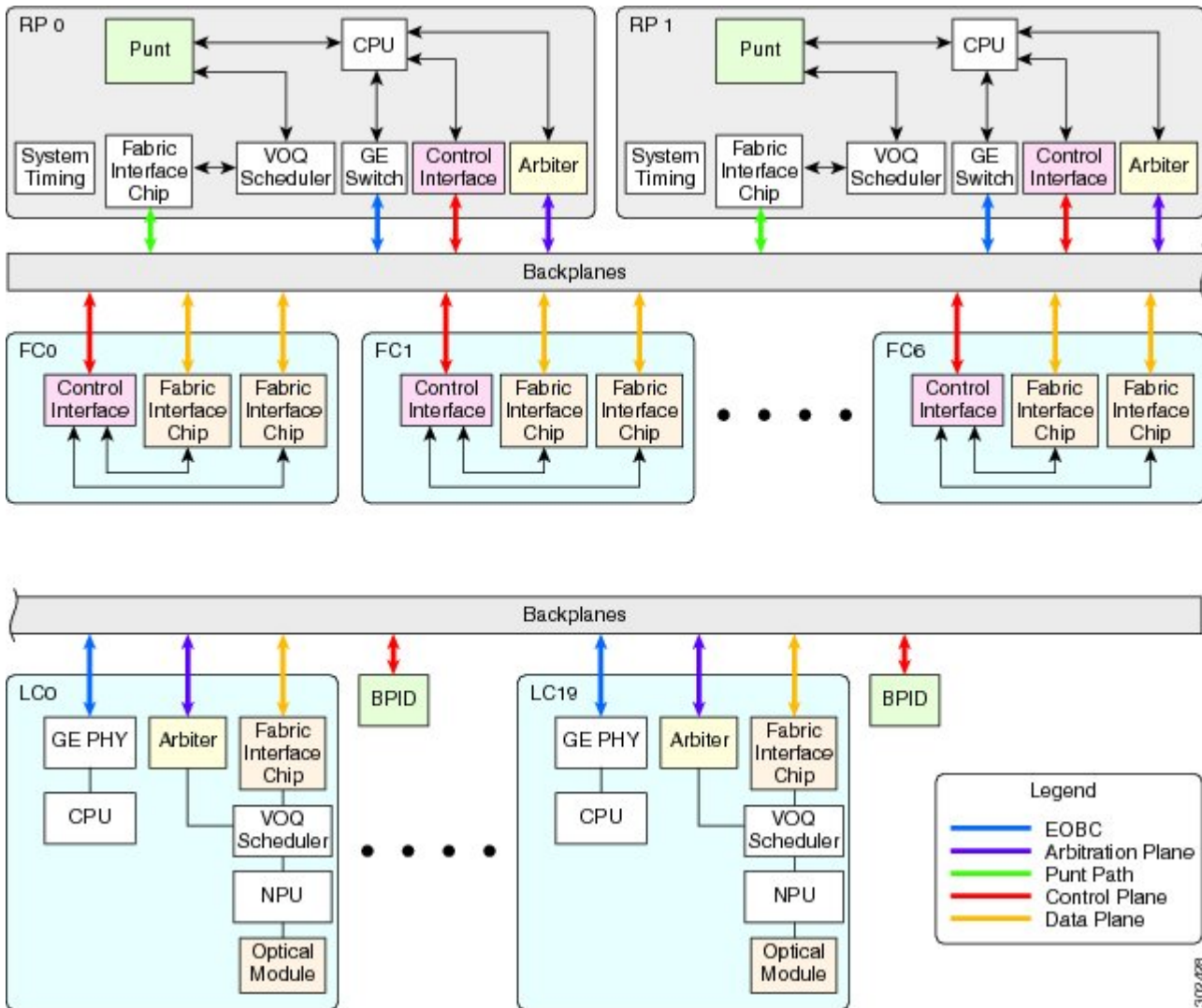


Figure 5: Major System Components and Interconnections in the Cisco ASR 9922 Router



## Route Switch Processor Card

The RSP card is the main control and switch fabric element in the Cisco ASR 9010 Router, Cisco ASR 9006 Router, Cisco ASR 9904 Router, Cisco and ASR 9906 Router. The Cisco ASR 9910 Router has Fabric Cards (FC) that acts as the main control element. The RSP card provides system control, packet switching, and timing control for the system. To provide redundancy, there can be two RSP cards in the system, one as the active control RSP and the other as the standby RSP. The standby RSP takes over all control functions if the active RSP fails.

The RSP-440 (second generation) and RSP-880 (third generation) router processor cards support the next generation of Cisco ASR 9000 Series line cards, and have increased bandwidth, memory, and processing capabilities.

RSP-440 Lite is a cost optimized version of the RSP-440 that offers the same 160 Gbps capacity which is license upgradeable to the 400Gbps capacity.

RSP880-LT is a cost optimized version of the RSP-880 that offers the same 400Gbps capacity.

RSP5 is the next-generation system processor for the Cisco ASR 9000 Series Routers. It supports high-density 100 Gigabit Ethernet line cards and provides backward compatibility with the Cisco ASR 9000 Series third generation family of line cards.

For detailed information about RSP cards, see [Route Switch Processor and Route Processor Cards](#).

## Route Processor Card

The RP card is the main control element in the Cisco ASR 9922 Router and Cisco ASR 9912 Router chassis. The switch fabric element has been moved to the FC cards. The RP card provides system control, packet switching, and timing control for the system. To provide redundancy, there are two RP cards in the system, one as the active control RP and the other as the standby RP. The standby RP takes over all control functions should the active RP fail.

The RP2/RP3 card has more processing power than the previous RP card. It also doubles the amount of storage and supported memory as well as the memory bandwidth. This provides the path to scale the number of routes up in this generation. In addition, the internal control plane bandwidth has been scaled up to allow better control of the linecards as the network bandwidth increases.

For detailed information about RP cards, see [Route Switch Processor and Route Processor Cards](#).

## Functional Description

In the Cisco ASR 9922 Router and Cisco ASR 9912 Router, the route processor functions are on the RP card, whereas the switch fabric is on the FC card. The RSP/RP card also provides shared resources for backplane Ethernet, timing, and chassis control. Redundant RSP/RP cards provide the central point of control for chassis provisioning, management, and data-plane switching.

### Switch Fabric

The switch fabric and route processor functions are combined on a single RSP card in the Cisco ASR 9010 Router, Cisco ASR 9006 Router, Cisco ASR 9904 Router and Cisco ASR 9910 Router. The switch fabric portion of the RSP card links the line cards together.

The switch fabric is configured as a single stage of switching with multiple parallel planes. The fabric is responsible for getting packets from one line card to another, but has no packet processing capabilities. Each fabric plane is a single-stage, non-blocking, packet-based, store-and-forward switch. To manage fabric congestion, the RSP card also provides centralized Virtual Output Queue (VOQ) arbitration.

The switch fabric is 1+1 redundant, with one copy of the fabric on each redundant RSP card. Each RSP card carries enough switching capacity to meet the router throughput specifications, allowing for full redundancy.

- In systems with the RSP card, the switch fabric delivers up to 80-Gbps per line card slot.
- In systems with the RSP-440 card or RSP-440 Lite card, the switch fabric delivers up to 220-Gbps per line card slot in redundant 1+1 mode and up to 440-Gbps per line card slot in non-redundant mode (two active RSPs).

- In systems with the RSP4-S card the switch fabric delivers up to 220-Gbps per line card slot in redundant 1+1 mode and up to 440-Gbps per line card slot in non-redundant mode (two active RSPs).
- In systems with the RSP-880 card or A9K-RSP880-LT card, the switch fabric delivers up to 440-Gbps per line card slot in redundant 1+1 mode and up to 880-Gbps per line card slot in non-redundant mode (two active RSPs).

- 

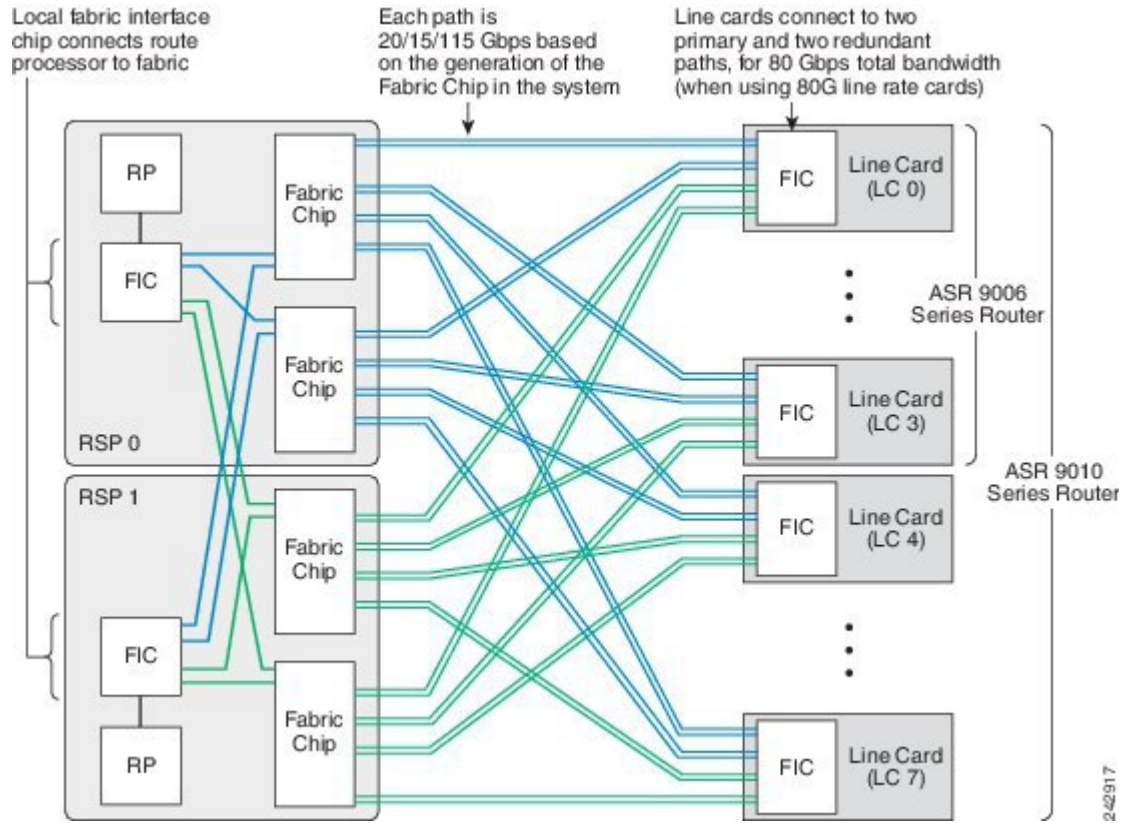
In the Cisco ASR 9922 Router and Cisco ASR 9912 Router, the switch fabric resides on dedicated line cards that connect to the backplanes alongside the RP cards.

- For first and second generation line cards, the Cisco ASR 9922 Router and Cisco ASR 9912 Router support up to five FCs in the chassis. Each FC card delivers 110G per slot. For example, when five FCs are installed in the chassis, the switch fabric is considered 4+1 redundant (one card in standby mode and four cards active), thereby delivering 440Gbps per line card slot. In non-redundant mode, the switch fabric delivers 550-Gbps per line card slot.
- For third generation line cards, the Cisco ASR 9922 Router and Cisco ASR 9912 Router support up to seven FCs in the chassis. Each FC card carries 230G per slot. For example, when five FCs are installed in the chassis, the switch fabric is 4+1 redundant (one card in standby mode and four cards active), thereby delivering 920-Gbps per slot (230x4). In non-redundant mode, the switch fabric delivers 1.15 Tbps per line card.

When all seven FC cards are installed in the chassis, the switch fabric is 6+1 redundant (one card in standby mode and six cards in active), and is capable of delivering up to 1.38 Tbps per slot (230x6).

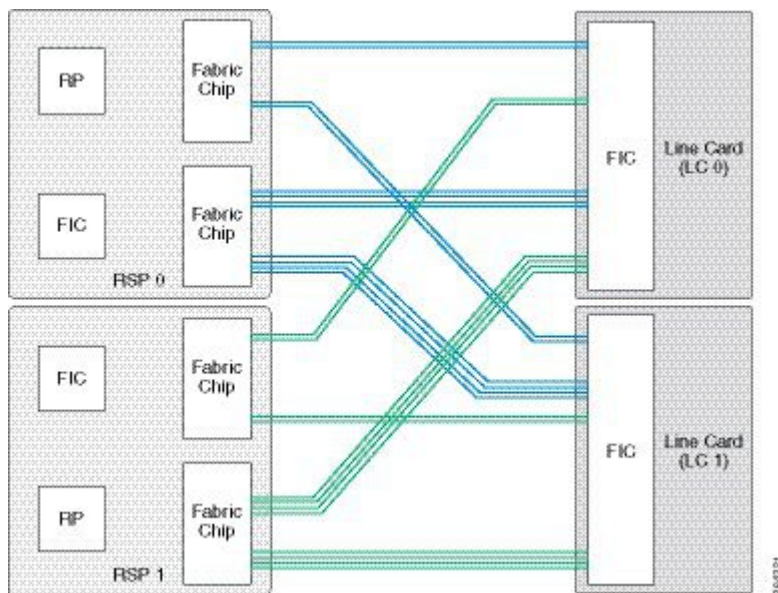
The following figure shows the switch fabric interconnections for the Cisco ASR 9006 Router and Cisco ASR 9010 Router.

Figure 6: Switch Fabric Interconnections—Cisco ASR 9006 Router and Cisco ASR 9010 Router



The following figure shows the switch fabric interconnections for the Cisco ASR 9904 Router.

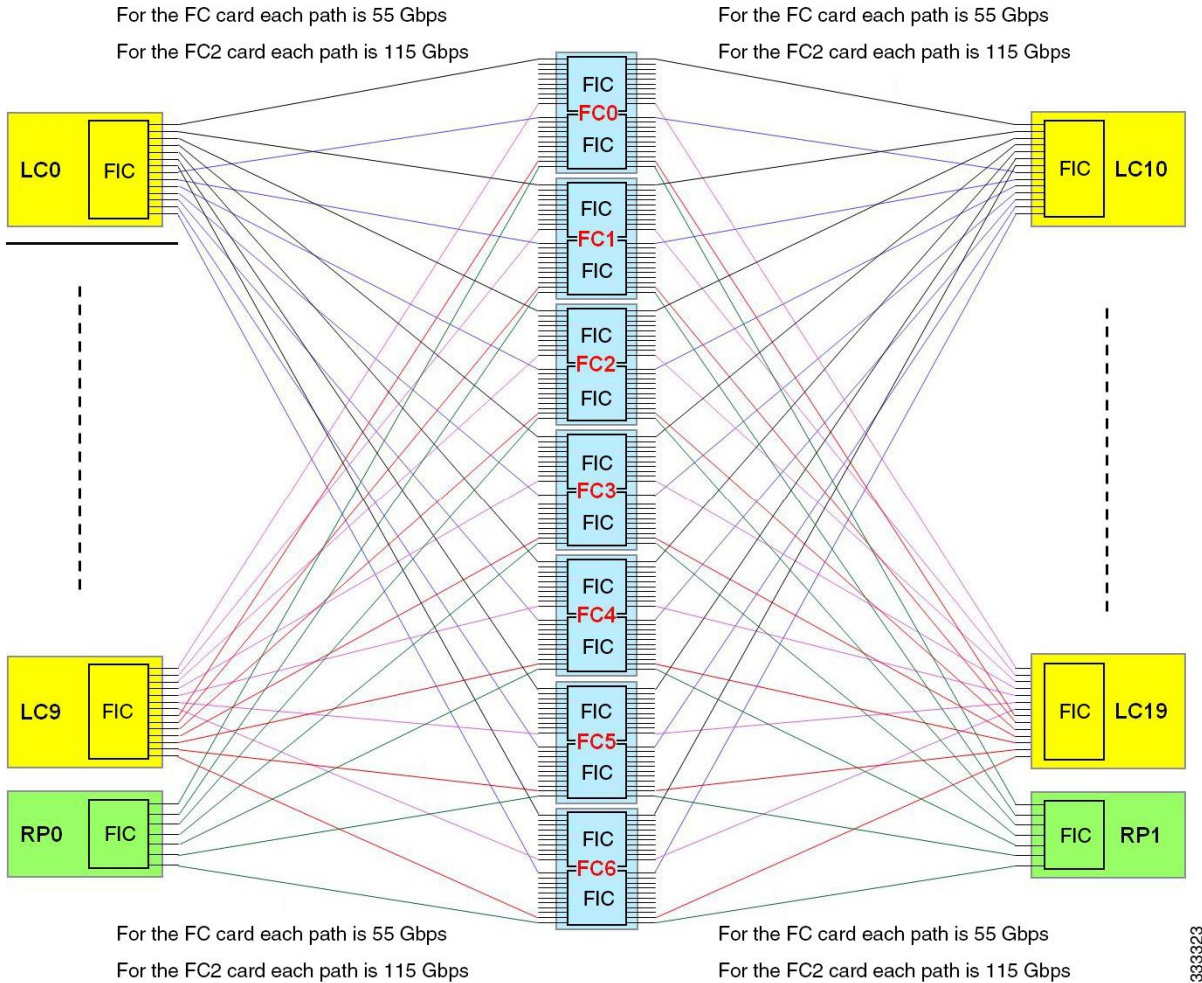
Figure 7: Switch Fabric Interconnections—Cisco ASR 9904 Router





The following figure shows the switch fabric interconnections for the Cisco ASR 9922 Router. The switch fabric for the Cisco ASR 9912 Router is the same except that the router supports up to ten line cards and has a single FIC instead of two FICs.

Figure 8: Switch Fabric Interconnections—Cisco ASR 9922 Router



## Unicast Traffic

Unicast traffic through the switch is managed by a VOQ scheduler chip. The VOQ scheduler ensures that a buffer is available at the egress of the switch to receive a packet before the packet can be sent into the switch. This mechanism ensures that all ingress line cards have fair access to an egress card, no matter how congested that egress card may be.

The VOQ mechanism is an overlay, separate from the switch fabric itself. VOQ arbitration does not directly control the switch fabric, but ensures that traffic presented to the switch will ultimately have a place to go when it exits the switch, preventing congestion in the fabric.

The VOQ scheduler is also one-for-one redundant, with one VOQ scheduler chip on each of the two redundant RSP/RP cards.

## Multicast Traffic

Multicast traffic is replicated in the switch fabric. For multicast (including unicast floods), the Cisco ASR 9000 Series Routers replicate the packet as necessary at the divergence points inside the system, so that the multicast packets can replicate efficiently without having to burden any particular path with multiple copies of the same packet.

The switch fabric has the capability to replicate multicast packets to downlink egress ports. In addition, the line cards have the capability to put multiple copies inside different tunnels or attachment circuits in a single port.

There are 64-K Fabric Multicast Groups (RSP 2-based line cards) or 128-K Fabric Multicast Groups (RSP-440 and RSP-880-based line cards) in the system, which allow the replication to go only to the downlink paths that need them, without sending all multicast traffic to every packet processor. Each multicast group in the system can be configured as to which line card and which packet processor on that card a packet is replicated to. Multicast is not arbitrated by the VOQ mechanism, but it is subject to arbitration at congestion points within the switch fabric.

## Route Processor Functions

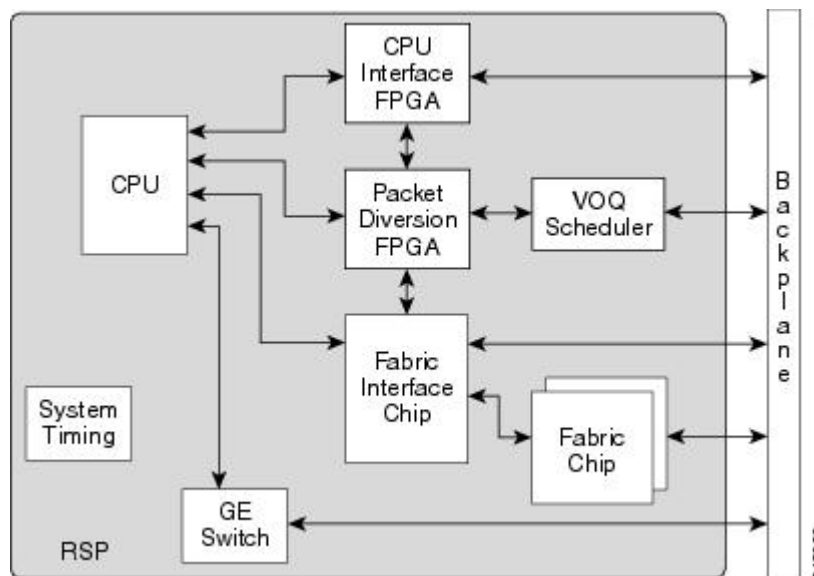
The Route Processor performs the ordinary chassis management functions. The ASR 9000 Series Routers run Cisco IOS XR software, so the Route Processor runs the centralized portions of the software for chassis control and management.

Secondary functions of the Route Processor include boot media, system timing (frequency and time of date) synchronization, precision clock synchronization, backplane Ethernet communication, and power control (through a separate CAN bus controller network).

The Route Processor communicates with other route processors and linecards over a switched Ethernet out-of-band channel (EOBC) for management and control purposes.

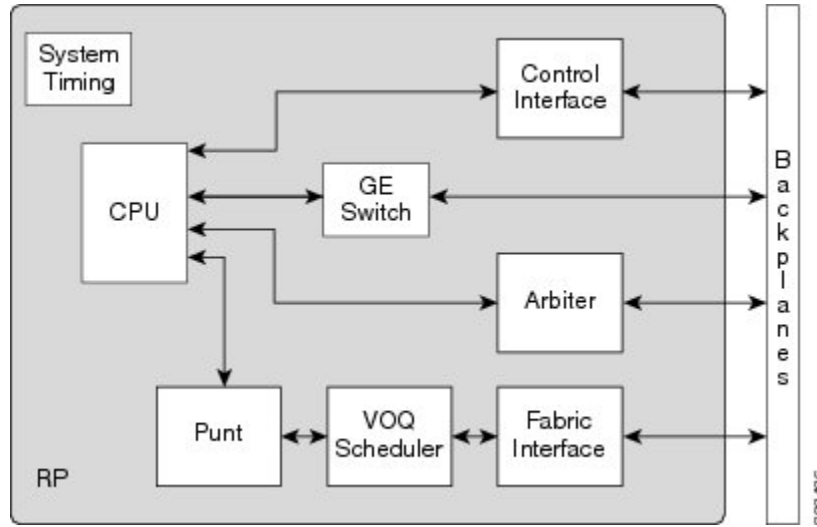
The following figure shows the route processor interconnections on the RSP.

**Figure 9: Route Processor Interconnections**



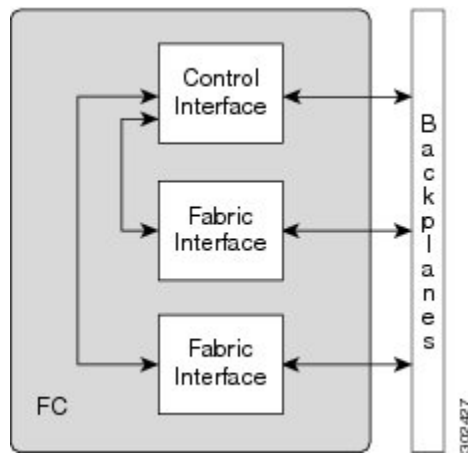
The following figure shows the component interconnections on the RP.

Figure 10: RP Component Interconnections



The following figure shows the component interconnections on the FC.

Figure 11: FC Component Interconnections



## Processor-to-Processor Communication

The RSP/RP card communicates with the control processors on each line card through the Ethernet out-of-band channel (EOBC) Gigabit Ethernet switch. This path is for processor-to-processor communication, such as IPC (InterProcess Communication). The Active RSP/RP card also uses the EOBC to communicate to the Standby RSP/RP card, if installed (the RSP-880 and RP2/RP3 cards have 10GE switches used for EOBC).

## Route Processor/Fabric Interconnect

The RSP card has a fabric interface chip (FIC) attached to the switch fabric and linked to the Route Processor through a Gigabit Ethernet interface through a packet diversion FPGA. This path is used for external traffic diverted to the RSP card by line card network processors.

The packet diversion FPGA has three key functions:

- Packet header translation between the header used by the fabric interface chip and the header exchanged with the Ethernet interface on the route processor.
- I/O interface protocol conversion (rate-matching) between the 20-Gbps DDR bus from the fabric interface chip and the 1-Gbps interface on the processor.
- Flow control to prevent overflow in the from-fabric buffer within the packet diversion FPGA, in case of fabric congestion.

The Route Processor communicates with the switch fabric via a FIC to process control traffic. The FIC has sufficient bandwidth to handle the control traffic and flow control in the event of fabric congestion. External traffic is diverted to the Route Processor by the line card network processors.

The RP and FC cards in the Cisco ASR 9922 Router have control interface chips and FICs attached to the backplanes that provide control plane and punt paths.

## Fabric Controller Card

On the Cisco ASR 9906 Router, Cisco ASR 9910 Router, Cisco ASR 9922 Router and Cisco ASR 9912 Router, the switch fabric resides on the switch fabric cards (FCs).

The switch fabric is configured as a single stage of switching with multiple parallel planes. The switch fabric is responsible for transporting packets from one line card to another but has no packet processing capabilities. Each fabric plane is a single-stage, non-blocking, packet-based, store-and-forward switch. To manage fabric congestion, the RP provides centralized Virtual Output Queue (VOQ) arbitration.

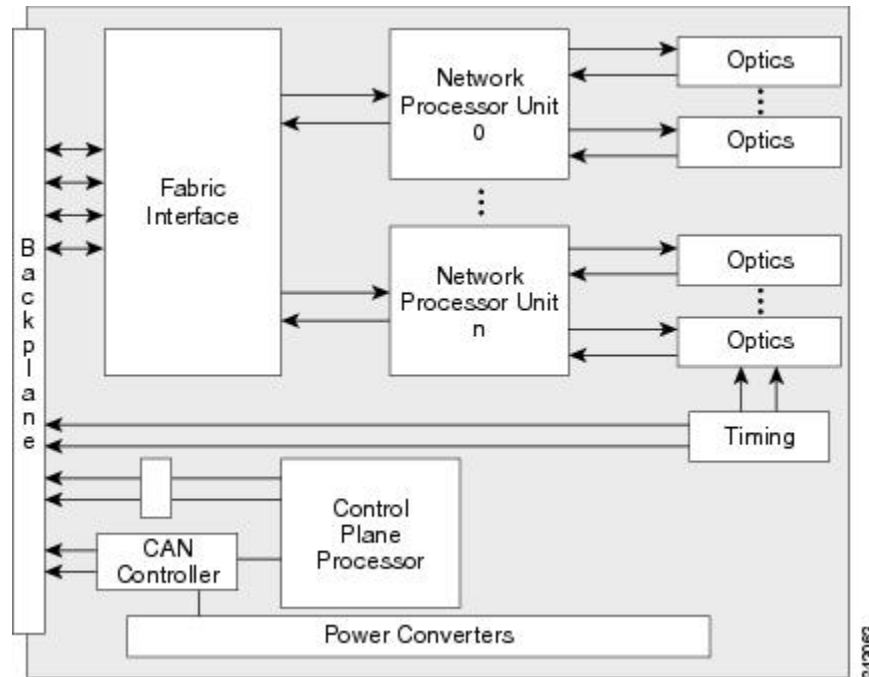
**Cisco ASR 9906 and 9910:** When two RSP cards and three FC cards are installed in the chassis, the switch fabric is 4+1 redundant. When two RSP cards and five FC cards are installed in the chassis, the switch fabric is 6+1 redundant. The switch fabric is fully redundant, with one copy of the fabric on each FC, and each FC carries enough switching capacity to meet the chassis throughput specifications.

**Cisco ASR 9912 and 9922:** When five FC cards are installed in the chassis, the switch fabric is 4+1 redundant. When all seven FC cards are installed in the chassis, the switch fabric is 6+1 redundant. The switch fabric is fully redundant, with one copy of the fabric on each FC, and each FC carries enough switching capacity to meet the chassis throughput specifications.

## Ethernet Line Cards

Ethernet line cards for the Cisco ASR 9000 Series Routers provide forwarding throughput of line rate for packets as small as 64 bytes. The small form factor pluggable (SFP, SFP+, QSFP+, XFP, CFP, or CPAK) transceiver module ports are polled periodically to keep track of state changes and optical monitor values. Packet features are implemented within network processor unit (NPU) ASICs.

Figure 12: General Line Card Data Plane Block Diagram



The optics, NPU and fabric interface handles all main data and also controls data that are routed to the RSP/RP cards. The other path is to the local CPU through a switched Gigabit Ethernet link. This second link is used to process control data routed to the line card CPU or packets sent to the RSP/RP card through the fabric link. The backplane Gigabit Ethernet links, one to each RSP/RP card, are used primarily for control plane functions such as application image download, system configuration data from the IOS XR software, statistics gathering, and line card power-up and reset control.

The number of NPUs will vary depending on the number of ports. Each NPU can handle millions of packets per second, accounting for ingress and egress, with a simple configuration. The more packet processing features enabled, the lower the packets per second that can be processed in the pipeline. There is a minimum packet size of 64 bytes, and a maximum packet size of 9 KB (9216 bytes) from the external interface.

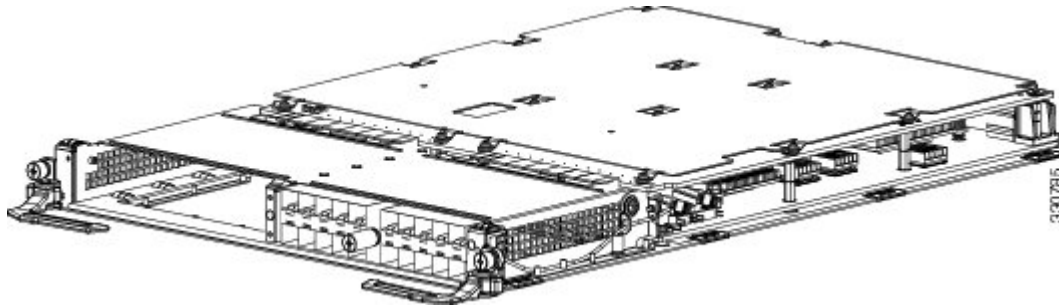
[http://www.cisco.com/en/US/docs/routers/asr9000/hardware/ethernet\\_line\\_card/installation/guide/asr9kELCIGbk.html](http://www.cisco.com/en/US/docs/routers/asr9000/hardware/ethernet_line_card/installation/guide/asr9kELCIGbk.html) For line card installation information, see the Cisco ASR 9000 Series Aggregation Services Routers Ethernet Line Card Installation Guide .

## Modular Line Cards

The modular line card is available in two network processing unit (80-Gb throughput versions). Each version is available in either a Service Edge Optimized (-SE) or Packet Transport Optimized (-TR) version. Both versions are functionally equivalent, but vary in configuration scale and buffer capacity.

The following figure shows a modular line card with a 20-port Gigabit Ethernet modular port adapter (MPA) installed in the lower bay. As shown in the figure, Bay 0 is the “upper” or “left” bay, and Bay 1 is the “lower” or “right” bay.

Figure 13: Modular Line Card



The MPA has Active/Link (A/L) LEDs visible on the front panel. Each A/L LED shows the status of both the port and the link. A green A/L LED means the state is on, the port is enabled, and the link is up. An amber A/L LED means the state is on, the port is enabled, and the link is down. An A/L LED that is off means the state is off, the port is not enabled, and the link is down.

For MPA installation information, see the Cisco ASR 9000 Series Aggregation Services Routers Ethernet Line Card Installation Guide .

## Power System Functional Description

The Cisco ASR 9000 Series Routers can be powered with an AC or DC source power. The power system is based on a distributed power architecture centered around a  $-54$  VDC printed circuit power bus on the system backplane.

The  $-54$  VDC system backplane power bus can be sourced from one of two options:

- AC systems—AC/DC bulk power supply tray connected to the user's 200 to 240 V +/- 10 percent (180 to 264 VAC) source.
- DC systems—DC/DC bulk power supply tray connected to the user's Central Office DC battery source ( $-48$ VDC to  $-60$ VDC nominal).

The system backplane distributes DC power from the backplane to each card and the fan trays. Each card has on-board DC-DC converters to convert the  $-54$  VDC from the distribution bus voltage to the voltages required by each particular card.

The power system is isolated from the central office by the transformers inside the power modules. It has single-point grounding on the  $-54$  VDC return.

All field replaceable modules of the power system are designed for Online Insertion and Removal (OIR), so they can be installed or removed without causing interruption to system operation.



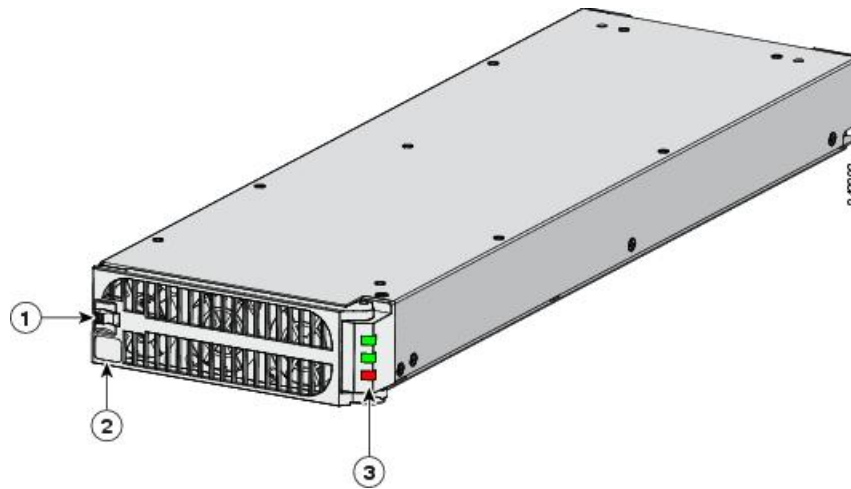
**Note** The Cisco ASR 9000 Series Routers have two available DC version 1 power modules, a 2100 W module and a 1500 W module. Both types of power modules can be used in a single chassis. The routers have one available DC version 2 power module (2100 W), and one available DC version 3 power module (4400 W).

## Power Modules

Multiple AC/DC power modules can be installed in each AC/DC power tray.

The following figure shows the version 1 power module.

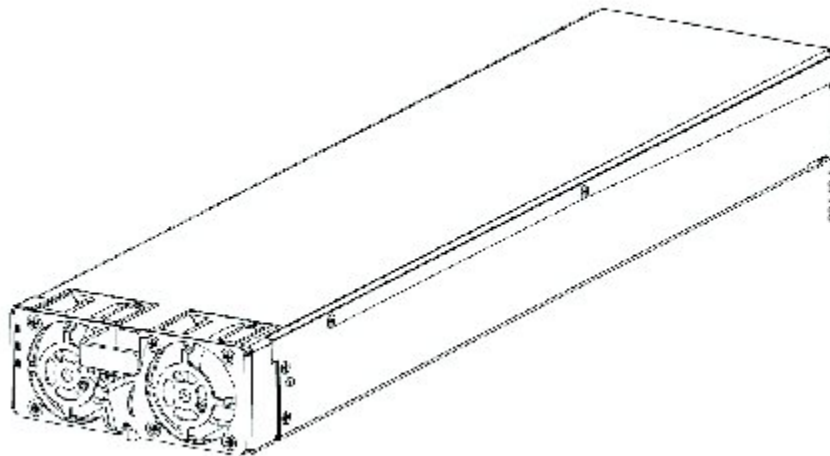
**Figure 14: Version 1 Power Module**



The following figure shows the version 2 power module. The version 3 power module is similar.

1. Door latch
2. Door and ejector lever
3. LED indicators

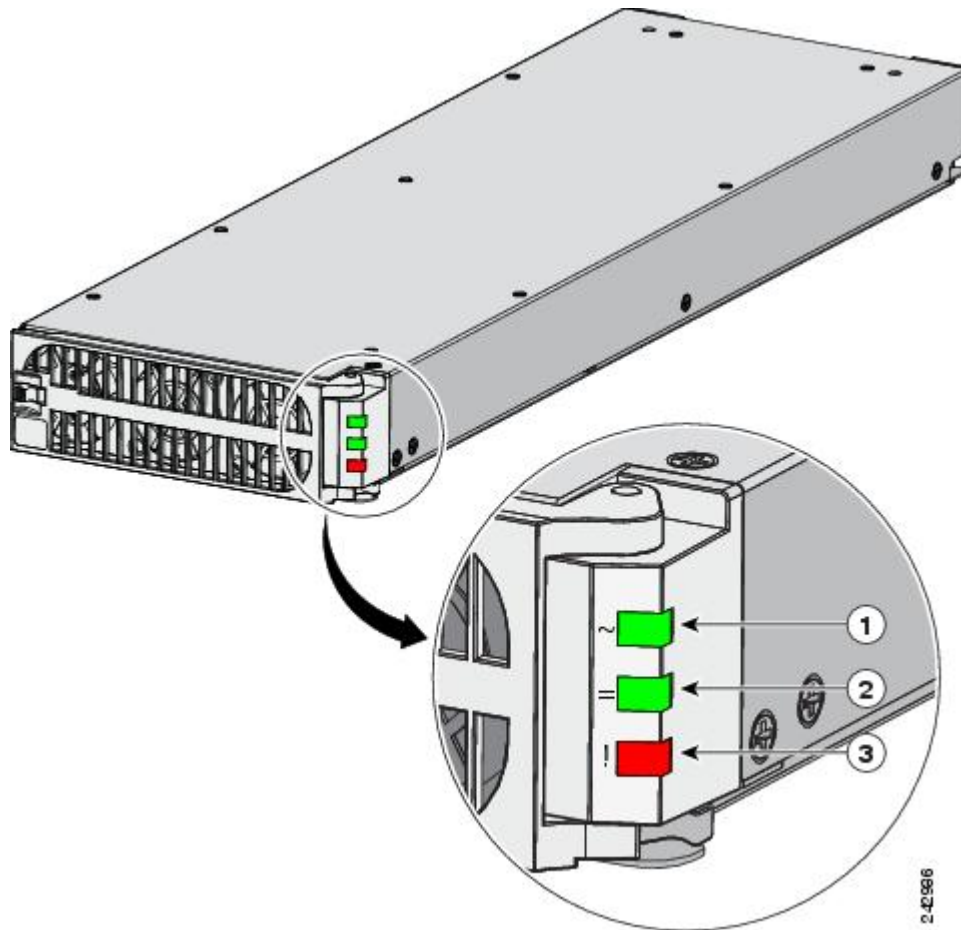
**Figure 15: Version 2 Power Module**



## Power Module Status Indicators

The following figure shows the status indicators for the version 1 power module.

Figure 16: Version 1 Power Module Status Indicators

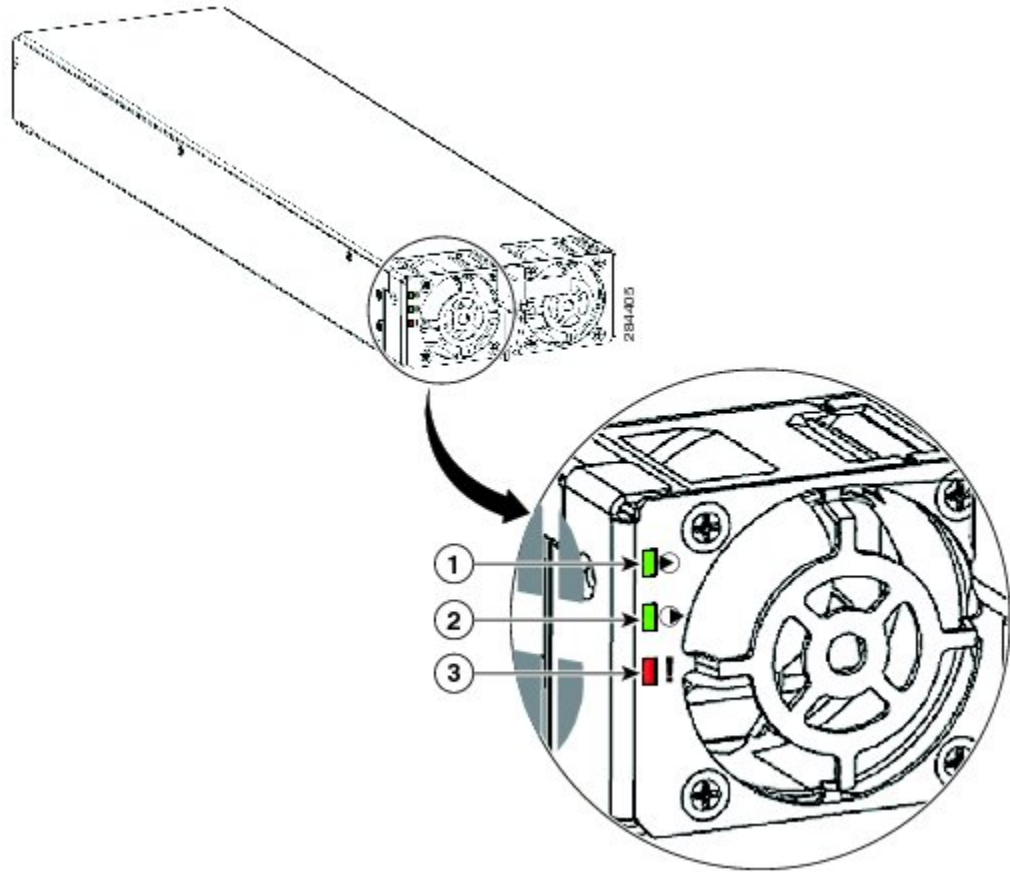


1	Input LED	ON continuously when the input voltage is present and within the correct range. BLINKING when the input voltage is out of acceptable range. OFF when no input voltage is present.
2	Output LED	ON when the power module output voltage is present. BLINKING when the power module is in a power limit or overcurrent condition.
3	Fault LED	ON indicates that a power supply failure has occurred.

The following figure shows the status indicators for the version 2 power module. The status indicators for the version 3 power module are similar.



Figure 17: Version 2 Power Module Status Indicators



1	Input LED	ON continuously when the input voltage is present and within the correct range. BLINKING when the input voltage is out of acceptable range. OFF when no input voltage is present.
2	Output LED	ON when the power module output voltage is present. BLINKING when the power module is in a power limit or overcurrent condition.
3	Fault LED	ON indicates that a power supply failure has occurred.

## System Power Redundancy

Both the AC and DC power systems have system power redundancy depending on the chassis configuration. Each tray can house up to four modules and can be configured for multiple power configurations. For more information about power system redundancy, see [Power Supply Redundancy](#).

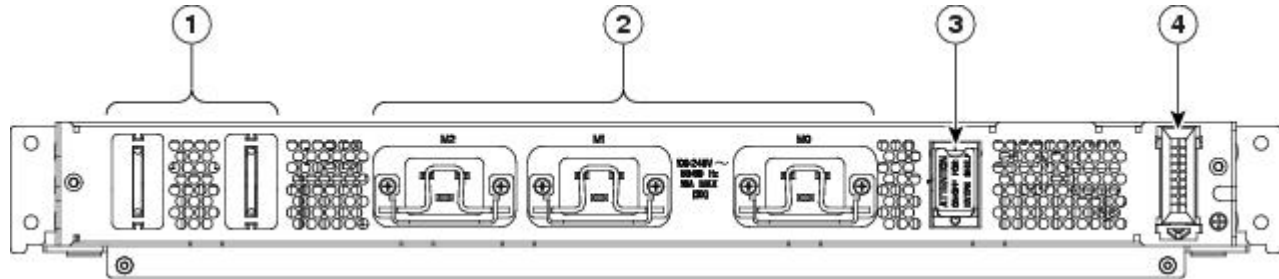
## AC Power Trays

The AC power provides 20-A UL/CSA-rated, 16-IEC-rated AC receptacles. The version 1 receptacle has a bail lock retention bracket to retain the power cord. The version 2 and version 3 receptacles have a clamp mechanism with a screw that can be tightened to retain the power cord. DC output power from the is connected

to the router by two power blades that mate to the power bus on the backplane. System communication is through a I2C cable from the backplane.

The following figure shows the back of the version 1.

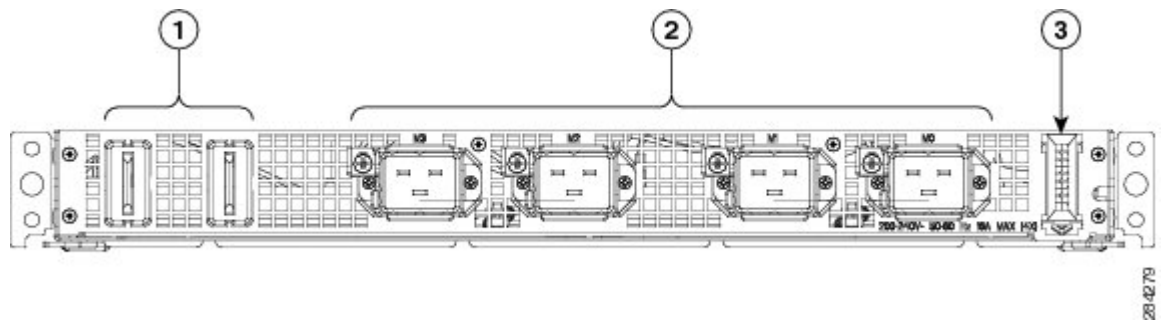
Figure 18: Version 1 Rear Panel



1 DC output power blades	3 Power switch
2 IEC input receptacles with retention brackets	4 I2C cable from backplane

The following figure shows the back of the version 2

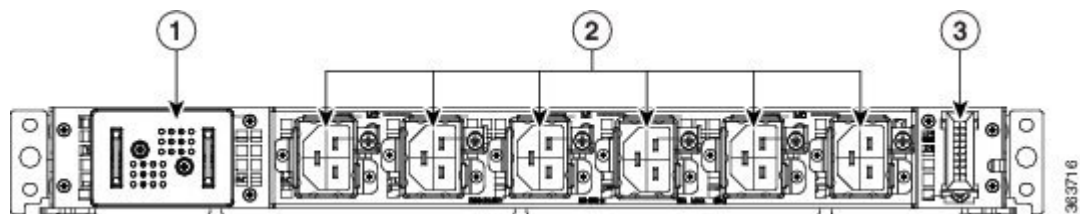
Figure 19: Version 2 Rear Panel



1 DC output power blades	3 I2C cable from backplane
2 IEC input receptacles with retention brackets	

The following figure shows the back of the version 3

Figure 20: Version 3 Rear Panel

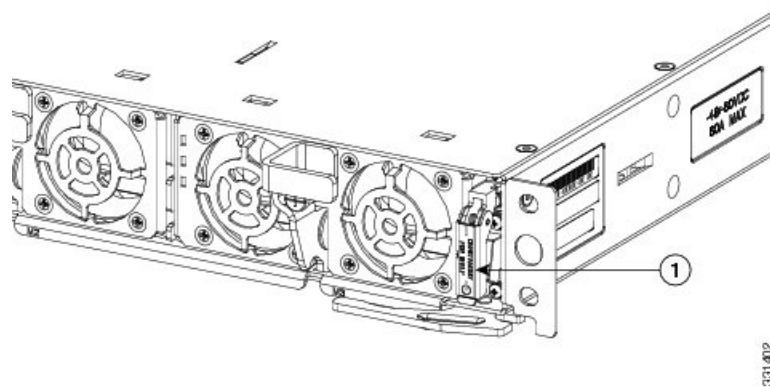


1 DC output power blades	3 I2C cable from backplane
2 IEC input receptacles with retention brackets	

## AC Tray Power Switch

Each provides a single-pole, single-throw power switch to power on and put in standby mode all power modules installed in the tray simultaneously. When the power modules are turned off, only the DC output power is turned off; the power module fans and LEDs still function. The power switch for the version 1 power tray is on the back of the tray, as shown in the following figure. The power switch for the version 2 and version 3 power tray is on the front is shown in the following figure.

**Figure 21: Location of AC Power Switch - Version 2 and Version 3 Power System**



1. Power switch

## AC Input Voltage Range

Each AC module accepts an individual single phase 220-VAC 20-A source. [AC Input Voltage Range](#) shows the limits of the specified AC input voltage. The voltages given are single phase power source.

## DC Output Levels

The output for each module is within the tolerance specifications ([Power System DC Output Levels](#)) under all combinations of input voltage variation, load variation, and environmental conditions. The combined, total module output power does not exceed 3000 W.

The AC tray output capacity depends on how many modules are populated. Maximum output current is determined by multiplying the maximum module current times module quantity. For example, to determine the maximum capacity with three power supply modules, multiply the current by three (x3).

## AC System Operation

This section describes the normal sequence of events for system AC power up and power down.

### Power Up

1. AC power is applied to the power tray by toggling the user's AC circuit breakers to the ON position.
2. AC/DC power supplies are enabled by toggling the Power On/Off logic switch located in each of the power trays to the ON position.
3. AC/DC modules in the power trays provide -54 VDC output within six seconds after the AC is applied.

4. The soft-start circuit in the logic cards takes 100 milliseconds to charge the input capacitor of the on-board DC/DC converters.
5. The card power controller MCU enables the power sequencing of the DC/DC converters and points of load (POLs) through direct communication using the PMBus interface to digital controllers.
6. The output of the DC/DC converters ramps up to regulation within 50 milliseconds maximum after the program parameters are downloaded to each POL and the On/Off control pin has been asserted.

## Power Down

1. Power conversion is disabled by toggling the Power On/Off logic switch to the OFF position or unplugging the power cords from the AC power source.
2. The AC/DC modules in the power trays stay within regulation for a minimum of 15 milliseconds after the AC power is removed.
3. The  $-54$  V to the logic card ramps down to  $-36$  V in 15 milliseconds minimum from the time the AC/DC modules starts ramping down from its minimum regulation level.
4. The DC/DC converters turn off immediately after the On/Off control pin is deasserted.
5. The output of the DC/DC converters stays in regulation for an additional 0.1 millisecond.

## DC Power Trays

The DC power tray ([DC Power Tray Rear Panel, on page 20](#)) provides two power feed connector banks: A feed and B feed. System communication is through a I2C cable from the backplane.

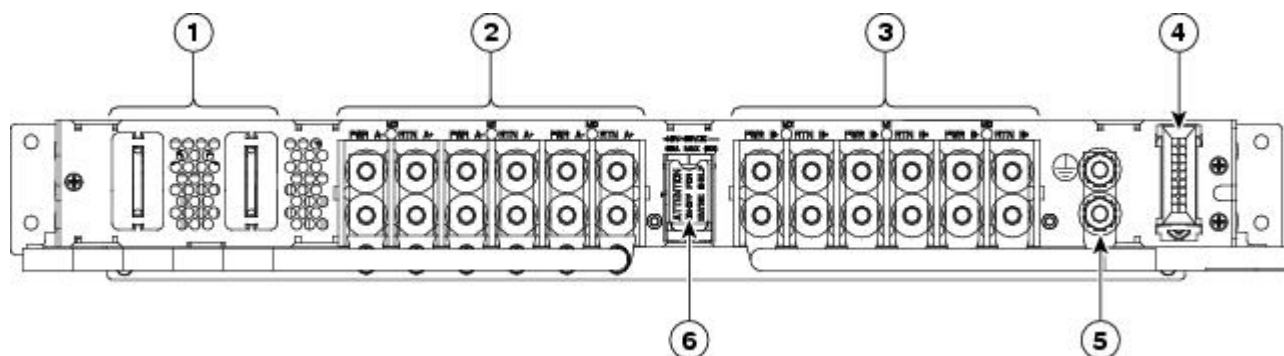
### DC Tray Power Switch

Each DC power tray provides a single-pole, single-throw power switch to power on and off all of the power modules installed in the tray simultaneously. When the power modules are turned off, only the DC output power is turned off; the power module fans and LEDs still function. The power switch is on the front panel.

### DC Power Tray Rear Panel

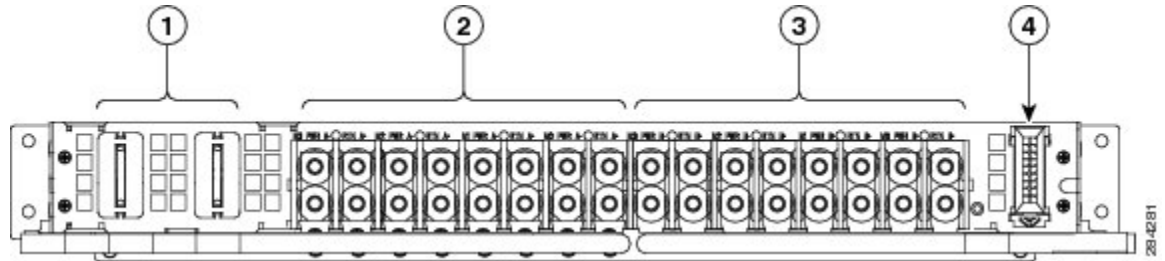
[Figure 22: DC Power Tray Rear Panel](#), on page 20 shows the rear panel of the power tray for the version 1 power system. [Figure 23: DC Power Tray Rear Panel - Cisco ASR 9006 Router and Cisco ASR 9904 Router \(Version 2 Power System\)](#), on page 21 shows the rear panel of the power tray for the version 2 power system. [Figure 24: DC Power Tray Rear Panel—Version 3 Power System](#), on page 21 shows the rear panel of the power tray for the version 3 power system.

**Figure 22: DC Power Tray Rear Panel**



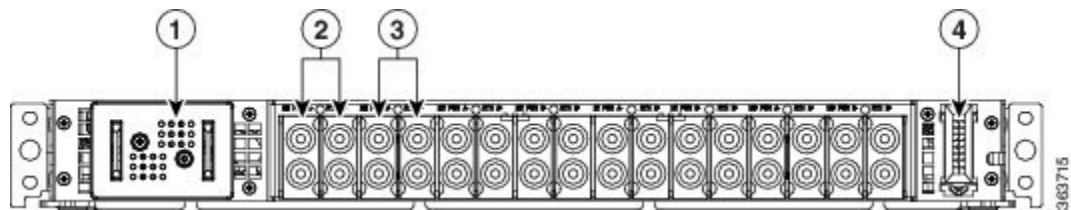
1 DC output power blades	4 I2C cable from backplane
2 “A” power feed connectors	5 Primary ground
3 “B” power feed connectors	6 Power switch

Figure 23: DC Power Tray Rear Panel - Cisco ASR 9006 Router and Cisco ASR 9904 Router (Version 2 Power System)



1 DC output power blades	3 “B” power feed connectors
2 “A” power feed connectors	4 I2C cable from backplane

Figure 24: DC Power Tray Rear Panel—Version 3 Power System



1 DC output power blades	3 “B” power feed connectors
2 “A” power feed connectors	4 I2C cable from backplane

## DC System Operation

This section describes the normal sequence of events for system DC power up and power down.

### Power Up

1. DC power is applied to the power tray by toggling the user’s DC circuit breakers to “ON” position.
2. DC/DC power supplies are enabled by toggling the Power On/Off logic switch located in each of the power tray to ON position.
3. DC/DC power supply modules in the power tray provides –54 VDC output within seven seconds after the DC is applied.
4. The soft-start circuit in the logic cards takes 100 milliseconds to charge the input capacitor of the on-board DC/DC converters.
5. The card power controller, MCU, enables the power sequencing of the DC/DC converters and POLs through direct communication using a PMBus interface to digital controllers such as LT7510 or through a digital wrapper such as LT2978.

- The output of the DC/DC converters ramp up to regulation within 50 milliseconds maximum. after the program parameters are downloaded to each POL and On/Off control pin has been asserted.

## Power Down

- Power conversion is disabled by toggling the Power On/Off logic switch in the power tray to OFF position.
- The DC/DC modules in the power tray stays within regulation for a minimum of 3.5 milliseconds after the Power On/Off logic switch is disabled.
- The –54V DC to the logic card ramps down to –36 VDC in 3.5 milliseconds minimum from the time the DC/DC modules starts ramping down from its minimum regulation level.
- The DC/DC converters powers off immediately after the On/Off pin is deasserted.
- The output of the DC/DC converters stays in regulation for an additional 0.1 millisecond.

## Cooling System Functional Description

The Cisco ASR 9000 Series Routers chassis is cooled by removable fan trays. The fan trays provide full redundancy and maintain required cooling if a single fan failure should occur. The following table describes the cooling paths for each router.

**Table 1: Cooling Paths for the Cisco ASR 9000 Series Routers**

Cisco ASR 9000 Series Routers	Chassis Cooling Path
Cisco ASR 9010 Router	Front-to-rear cooling path ( <a href="#">Figure 25: Cisco ASR 9010 Router Chassis Cooling Path—Side View , on page 23</a> ). The inlet is at the bottom front of the chassis, and the exhaust is at the upper rear.
Cisco ASR 9006 Router	Side-to-top to rear cooling path ( <a href="#">Figure 26: Cisco ASR 9006 Router Chassis Cooling Path , on page 23</a> ). The inlet is at the right side of the chassis, and the exhaust is at the upper rear.
Cisco ASR 9904 Router	Side-to-side cooling path ( <a href="#">Figure 27: Cisco ASR 9904 Router Chassis Cooling Path, on page 24</a> ). The inlet is at the right side of the cage, and the exhaust is at the left side.
Cisco ASR 9906 Router	Front-to-top-to-rear cooling path ( <a href="#">Figure 28: Cisco ASR 9906 Router Chassis Cooling Path, on page 24</a> ). The inlet is at the bottom front of the chassis, and the exhaust is at the lower rear.
Cisco ASR 9910 Router	Front-to-rear cooling path ( <a href="#">Figure 29: Cisco ASR 9910 Router Chassis Cooling Path—Side View , on page 25</a> ). The inlet is at the bottom front of the chassis, and the exhaust is at the upper rear.
Cisco ASR 9922 Router	Front-to-rear cooling path ( <a href="#">Figure 30: Cisco ASR 9922 Router Chassis Cooling Path—Side View , on page 26</a> ). The inlet is at the front of the middle cage, and the exhaust is at the upper and lower rear.
Cisco ASR 9912 Router	Front-to-rear cooling path ( <a href="#">Figure 31: Cisco ASR 9912 Router Chassis Cooling Path—Side View , on page 27</a> ). The inlet is at the bottom front of the chassis, and the exhaust is at the upper rear



Figure 25: Cisco ASR 9010 Router Chassis Cooling Path—Side View

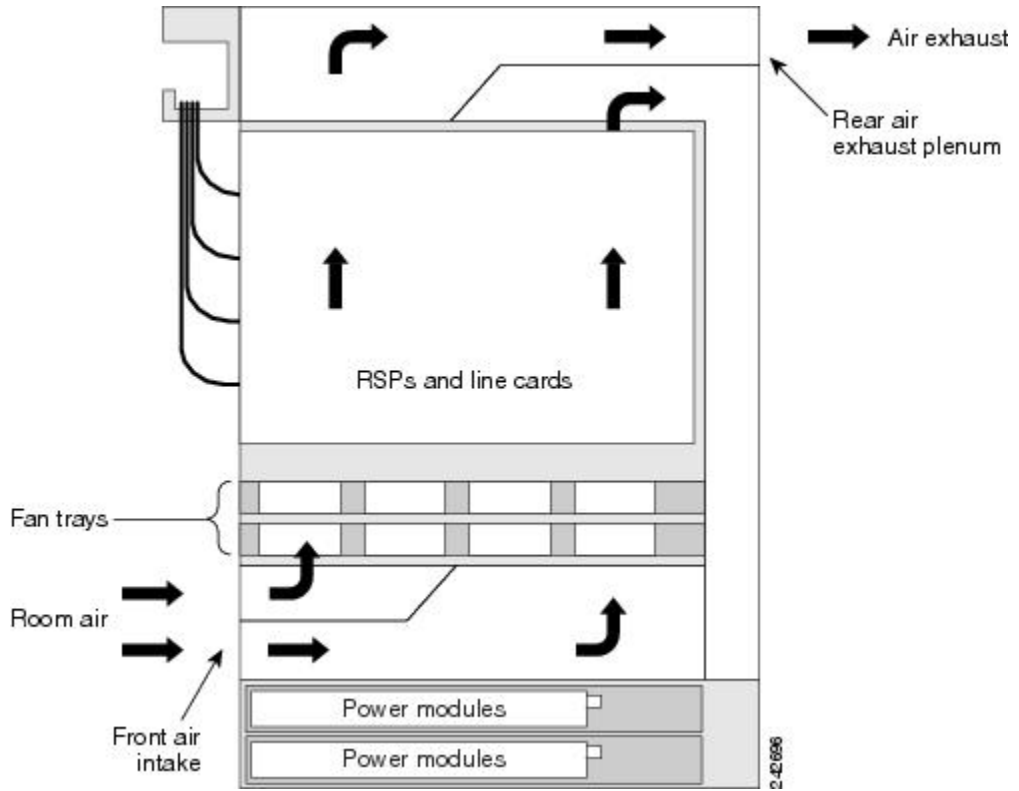


Figure 26: Cisco ASR 9006 Router Chassis Cooling Path

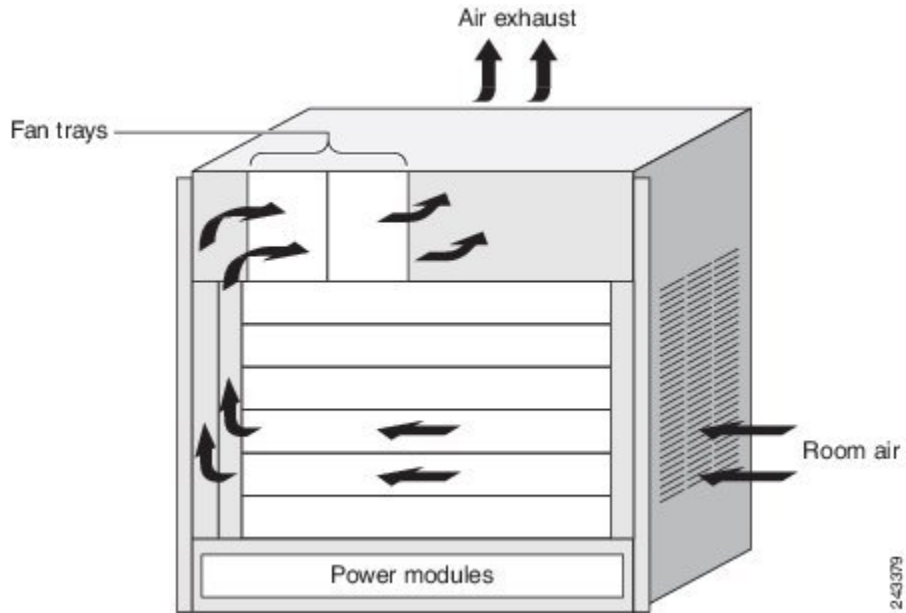


Figure 27: Cisco ASR 9904 Router Chassis Cooling Path

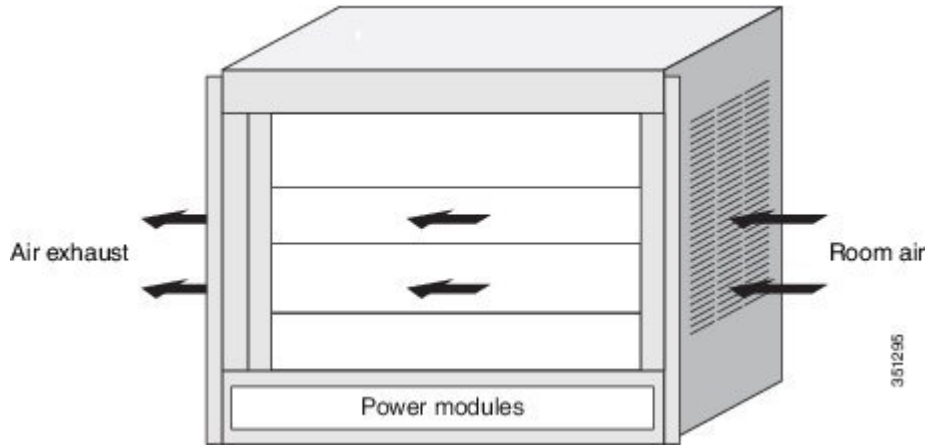


Figure 28: Cisco ASR 9906 Router Chassis Cooling Path

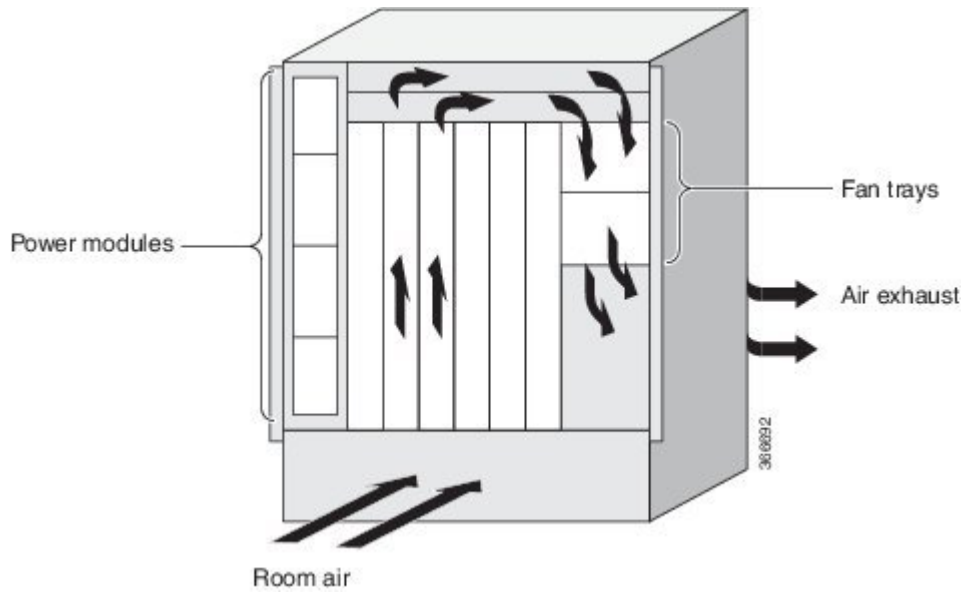
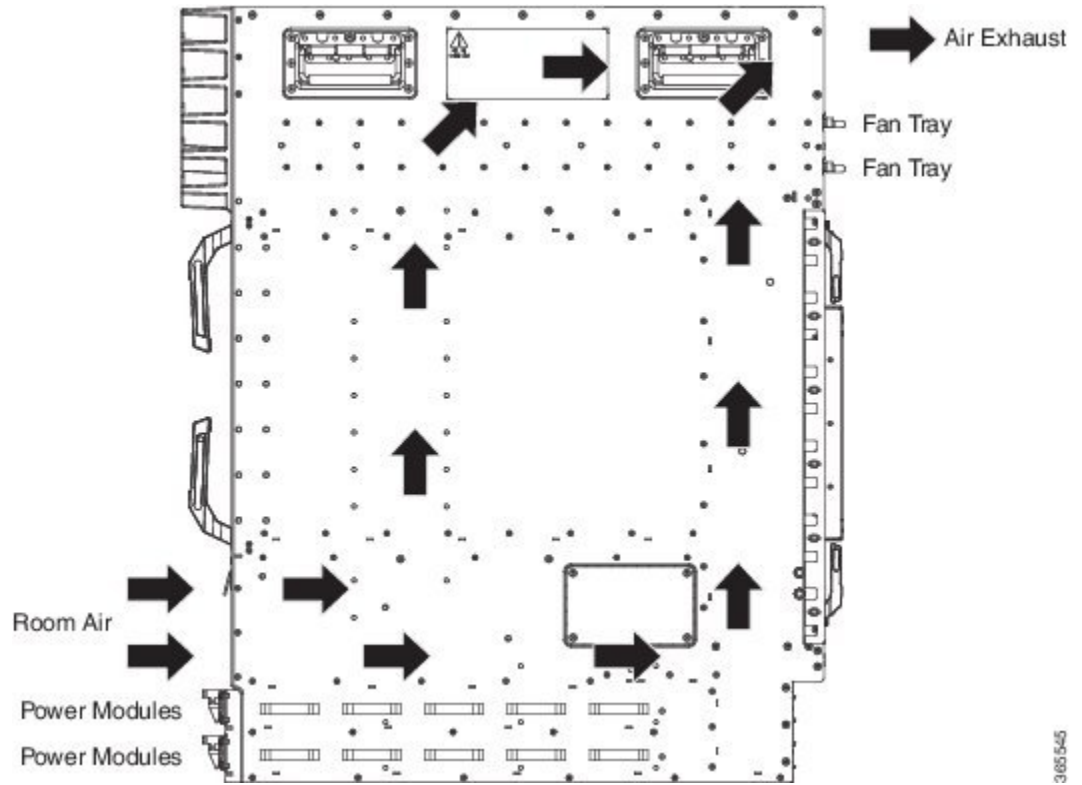


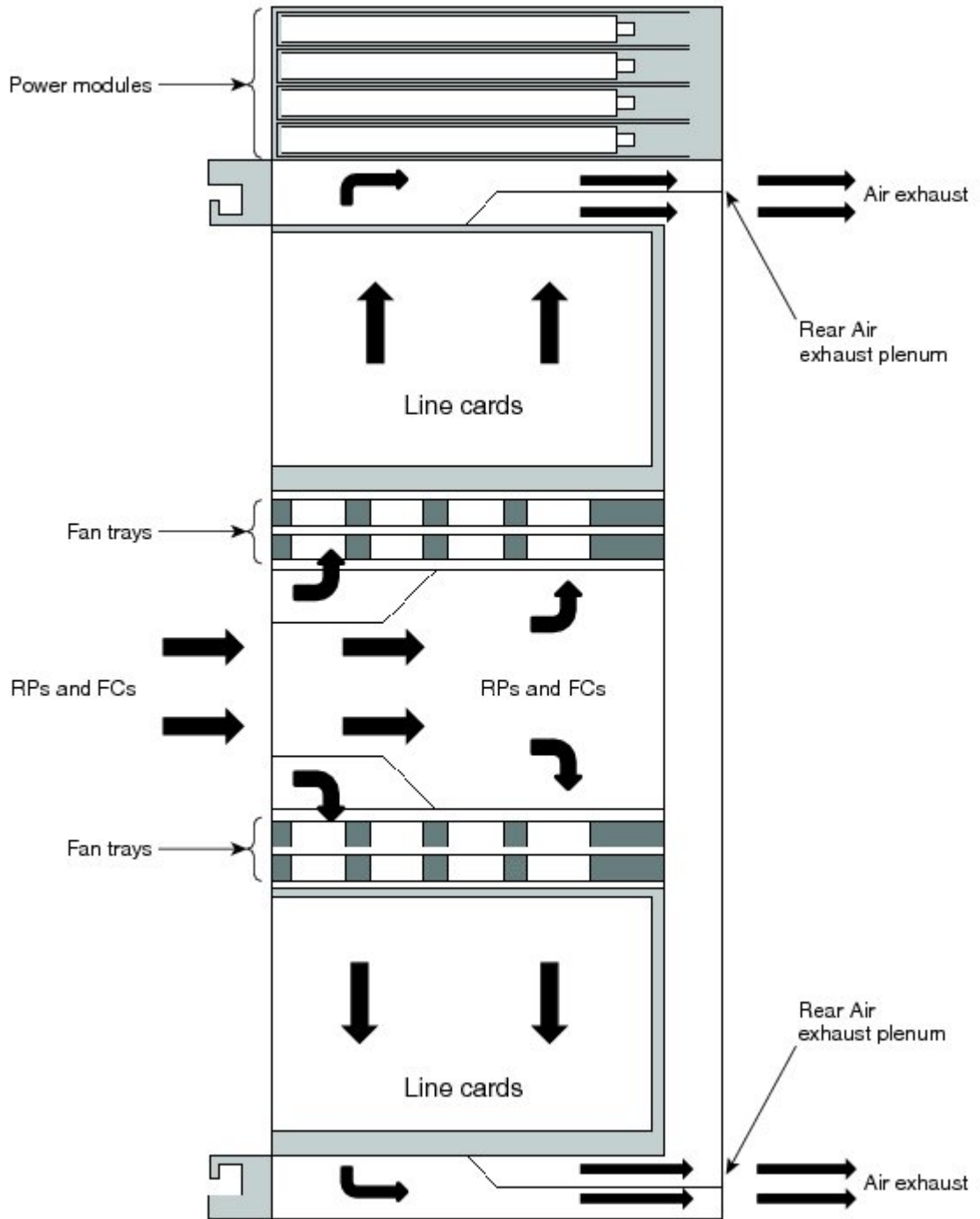


Figure 29: Cisco ASR 9910 Router Chassis Cooling Path—Side View



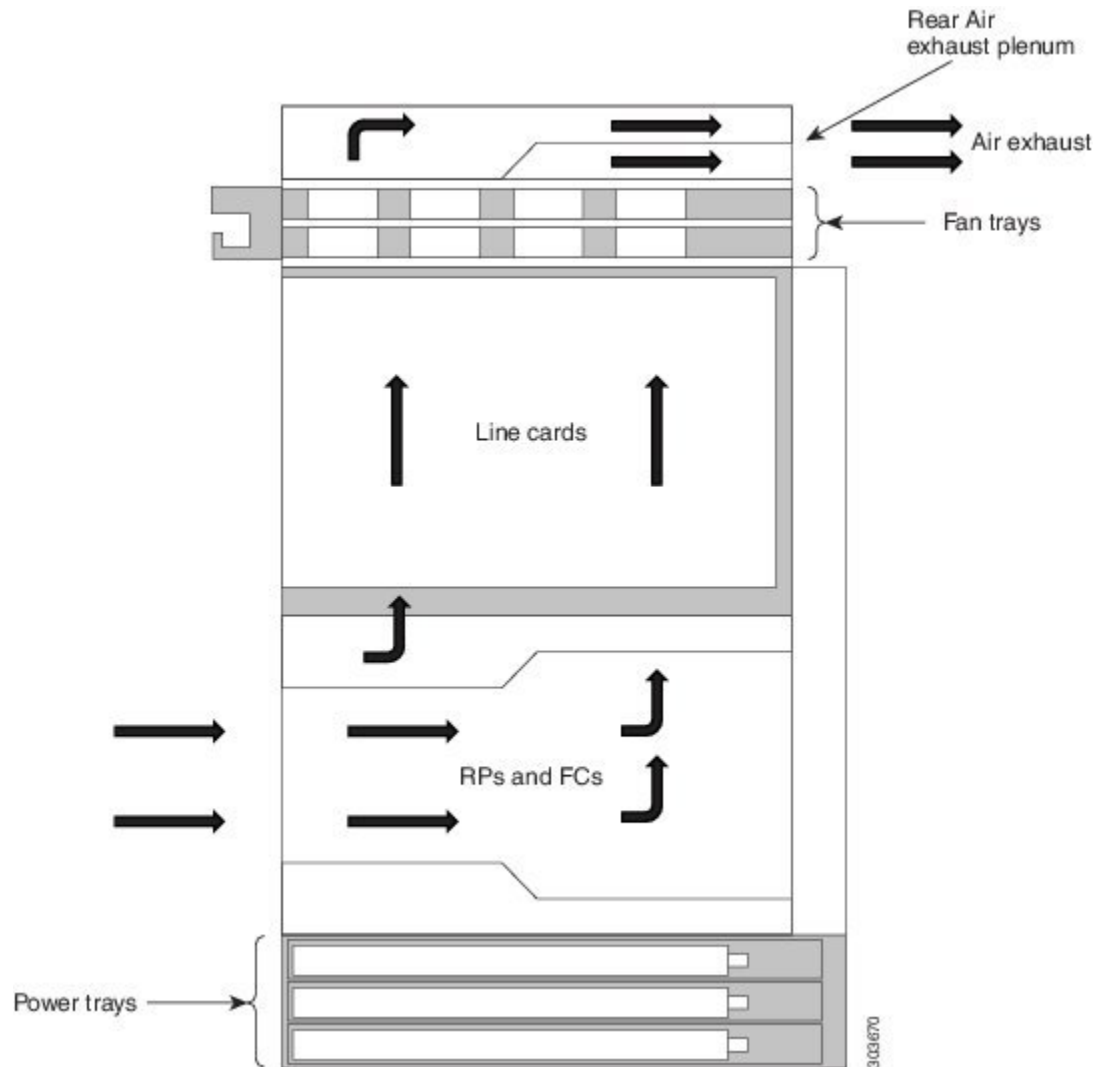
385545

Figure 30: Cisco ASR 9922 Router Chassis Cooling Path—Side View



343857

Figure 31: Cisco ASR 9912 Router Chassis Cooling Path—Side View



## Fan Trays

### Cisco ASR 9010 Router Fan Trays

The Cisco ASR 9010 Router contains two fan trays for redundancy. The fan tray has an LED indicator to indicate fan tray status. If a fan tray fails, it is possible to swap a single fan tray assembly while the system is operational. Fan tray removal does not require removal of any cables.

- Fan tray status LED
- The fan tray contains 12 axial 120-mm (4.72-in) fans. There is a fan control board at the back end of each tray with a single power/data connector that connects with the backplane.
- The fan tray aligns through two guide pins inside the chassis, and it is secured by two captive screws. The controller board floats within the fan tray to allow for alignment tolerances.

- A finger guard is adjacent to the front of most fans to keep fingers away from spinning fan blades during removal of the fan tray.
- The maximum weight of the fan tray is 13.82 lb (6.29 kg).

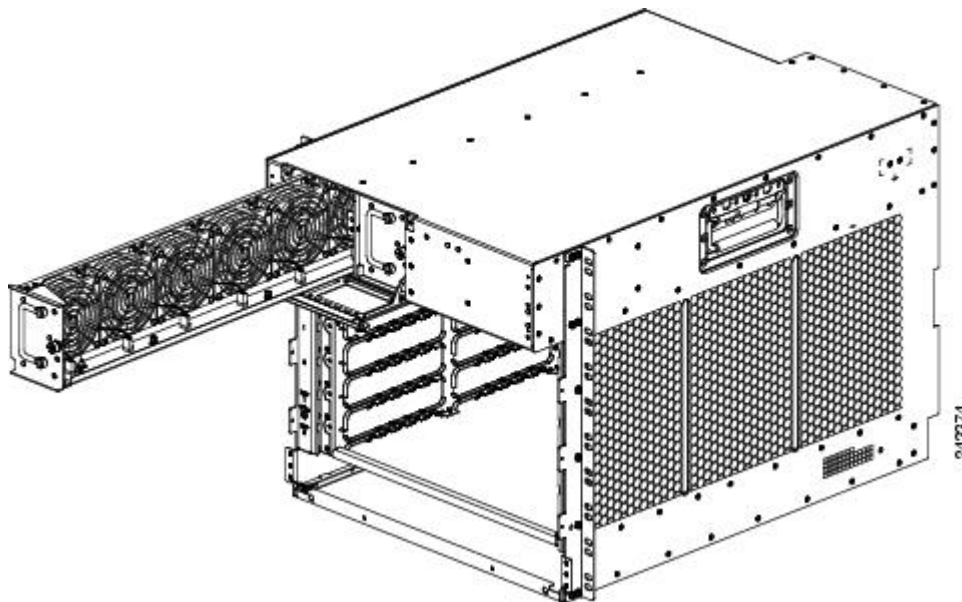
## Cisco ASR 9006 Router Fan Trays

The Cisco ASR 9006 Router contains two fan trays for redundancy. If a fan tray fails, it is possible to swap a single fan tray assembly while the system is operational. Fan tray removal does not require removal of any cables.



**Note** Both fan trays are required for normal system operation for the Cisco ASR 9010 Router and Cisco ASR 9006 Router. If both fan trays in the router are pulled out or are not installed, a critical alarm is raised.

*Figure 32: Cisco ASR 9006 Router Fan Tray*

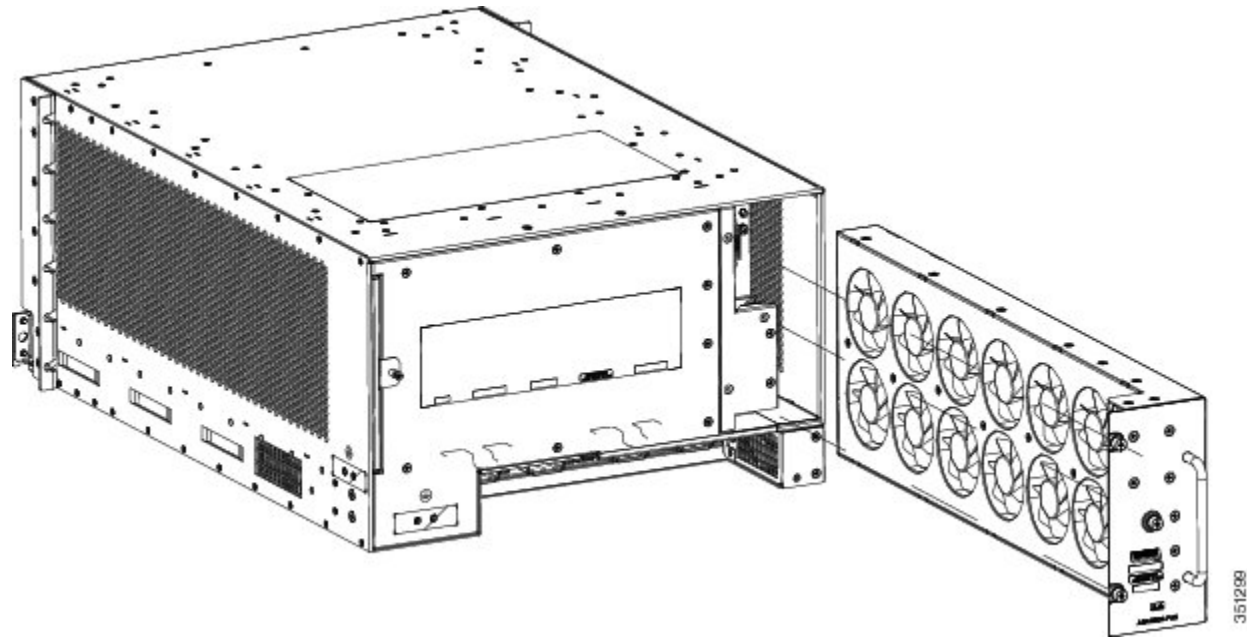


- The fan tray contains six axial 92-mm (3.62-in) fans. There is a fan control board at the back end of each tray with a single power/data connector that connects with the backplane.
- The fan tray aligns through two guide pins inside the chassis, and is secured by one captive screw. The controller board floats within the fan tray to allow for alignment tolerances.
- A finger guard is adjacent to the front of most of the fans to keep fingers away from spinning fan blades during removal of the fan tray.
- The maximum weight of the fan tray is 39.7 lb (18.0 kg).

## Cisco ASR 9904 Router Fan Tray

The Cisco ASR 9904 Router contains a single fan tray. If a fan tray fails, it is possible to swap a single fan tray assembly while the system is operational. Replace the missing fan tray within 4 minutes.

Figure 33: Cisco ASR 9904 Router Fan Tray



- The fan tray contains twelve axial 88-mm (3.46-in) fans. There is a fan control board at the back end of the tray with a single power/data connector that connects with the backplane
- The fan tray aligns through two guide pins inside the chassis, and it is secured by one captive screw. The controller board floats within the fan tray to allow for alignment tolerances.
- A finger guard is adjacent to the front of most of the fans to keep fingers away from spinning fan blades during removal of the fan tray.
- The maximum weight of the fan tray is 11.0 lb (4.99 kg).

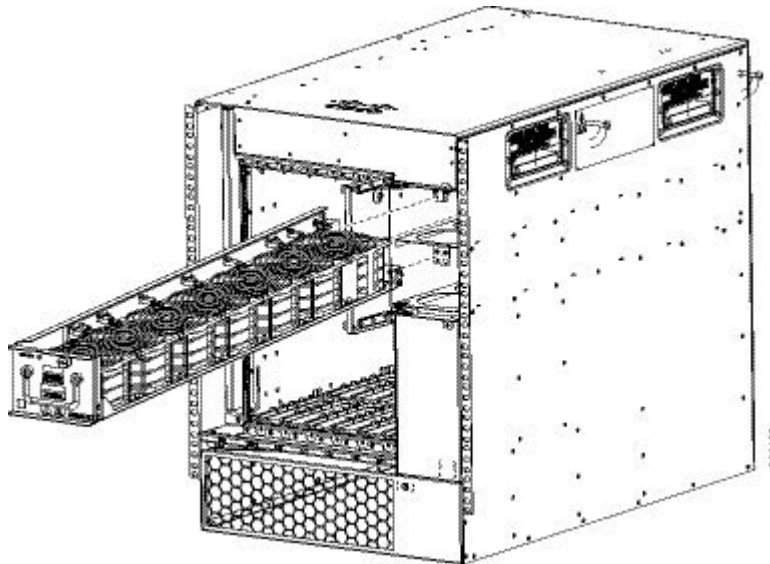
## Cisco ASR 9906 Router Fan Trays

The Cisco ASR 9906 Router contains two fan trays for redundancy. If a fan tray fails, it is possible to swap a single fan tray assembly while the system is operational. Fan tray removal does not require removal of any cables.



**Note** Both fan trays are required for normal system operation for the Cisco ASR 9906 Router. If both fan trays in the router are pulled out or are not installed, a critical alarm is raised.

Figure 34: Cisco ASR 9906 Router Fan Tray



- The fan tray contains seven axial 92-mm (3.62-in) fans. There is a fan control board at the back end of each tray with a single power/data connector that connects with the backplane.
- The fan tray aligns through two guide pins inside the chassis, and is secured by one captive screw. The controller board floats within the fan tray to allow for alignment tolerances.
- A finger guard is adjacent to the front of most of the fans to keep fingers away from spinning fan blades during removal of the fan tray.
- The maximum weight of the fan tray is 8.0 lb (3.63 kg).

## Cisco ASR 9910 Router Fan Trays

The Cisco ASR 9910 Router contains two fan trays for redundancy. The fan tray has an LED indicator to indicate fan tray status. If a fan tray fails, it is possible to swap a single fan tray assembly while the system is operational. Fan tray removal does not require removal of any cables.

1. Fan tray status LED
2. The fan tray contains 12 axial 134-mm (5.27-in) fans. There is a fan control board at the back end of each tray with a single power/data connector that connects with the backplane.
3. The fan tray aligns through two guide pins inside the chassis, and it is secured by two captive screws. The controller board floats within the fan tray to allow for alignment tolerances.
4. A finger guard is adjacent to the front of most fans to keep fingers away from spinning fan blades during removal of the fan tray.
5. The maximum weight of the fan tray is 26.55 lb (12.04 kg).

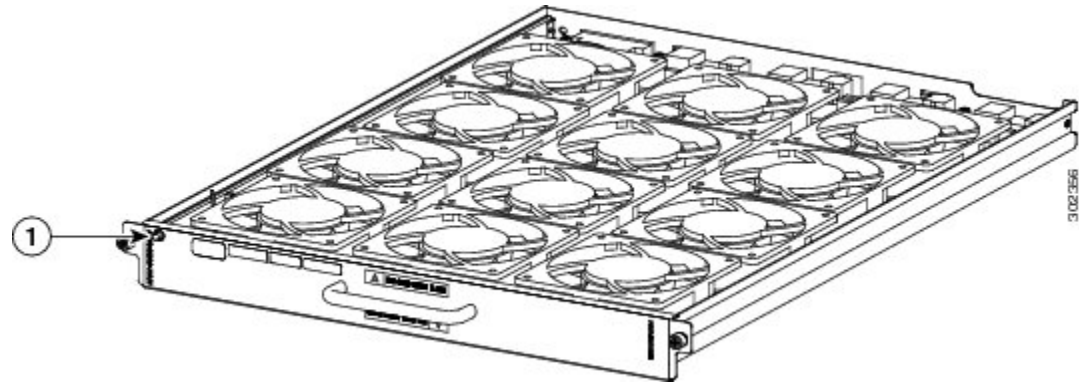
## Cisco ASR 9922 Router and Cisco ASR 9912 Router Fan Trays

The Cisco ASR 9922 Router contains four fan trays, and the Cisco ASR 9912 Router contains three fan trays for redundancy. The fan tray has an LED indicator to indicate fan tray status. If a fan tray fails, it is possible to swap a single fan tray assembly while the system is operational. Fan tray removal does not require removal of any cables.



**Note** Do not operate the chassis with any of the fan trays completely missing. Replace any missing fan tray within five minutes.

*Figure 35: Cisco ASR 9922 Router and Cisco ASR 9912 Router Fan Tray*



1. Fan tray status LED
2. The fan tray contains 12 axial 120-mm (4.72-in) fans. There is a fan control board at the back end of each tray with a single power/data connector that connects with the backplane.
3. The fan tray aligns through two guide pins inside the chassis, and it is secured by two captive screws. The controller board floats within the fan tray to allow for alignment tolerances.
4. A finger guard is adjacent to the front of most fans to keep fingers away from spinning fan blades during removal of the fan tray.
5. The maximum weight of the fan tray is 18.00 lb (8.16 kg).
6. The fan tray width is increased from 16.3 inches to 17.3 inches. The overall fan tray depth remains the same at 23 inches. The individual fan current rating is increased to 2 A to support higher speeds.

## Fan Tray Status Indicators

The fan tray has a Run/Fail status LED on the front panel to indicate fan tray status.

After fan tray insertion into the chassis, the LED lights up temporarily appearing yellow. During normal operation:

- The LED lights green to indicate that all fans in the module are operating normally.
- The LED lights red to indicate a fan failure or another fault in the fan tray module. Possible faults are:
  - Fan stopped.
  - Fans running below required speed to maintain sufficient cooling.
  - Controller card has a fault.

## Fan Tray Servicing

No cables or fibers must be moved during installation or removal of the fan tray(s). Replacing fan trays does not interrupt service.

## Slot Fillers

To maintain optimum cooling performance in the chassis and at the slot level, unused slots must be filled with card blanks or flow restrictors. These slot fillers are simple sheet metal only and are not active. Software cannot detect their presence.

## Chassis Air Filters (Version 1 and Version 2)

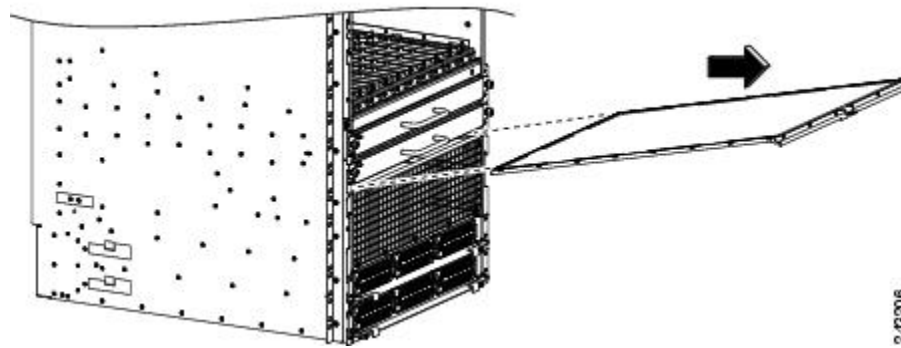
The chassis air filters in the Cisco ASR 9000 Series Routers are NEBS compliant. The filter is not serviceable but is a field replaceable unit. Replacing the filter does not interrupt service. The following table describes the chassis air filter locations for the Cisco ASR 9000 Series Routers.

**Table 2: Chassis Air Filter Locations for the Cisco ASR 9000 Series Routers**

Cisco ASR 9000 Series Routers	Air Filter Locations
Cisco ASR 9010 Router	A single air filter is located underneath the fan trays ( <a href="#">Figure 36: Cisco ASR 9010 Router Chassis Air Filter, on page 33</a> ).
Cisco ASR 9006 Router	A single air filter is located along the right side of the chassis, and is accessible from the rear of the chassis ( <a href="#">Figure 37: Cisco ASR 9006 Router Chassis Air Filter, on page 33</a> ).
Cisco ASR 9904 Router	A single air filter is located along the right side of the chassis, and is accessible from the rear of the chassis ( <a href="#">Figure 38: Cisco ASR 9904 Router Air Filter, on page 34</a> ).
Cisco ASR 9906 Router	A single air filter is located underneath the line card cage, accessible from the front of the chassis ( <a href="#">Figure 39: Cisco ASR 9906 Router Chassis Air Filter, on page 34</a> ).
Cisco ASR 9910 Router	A single air filter is located underneath the fan trays ( <a href="#">Figure 40: Cisco ASR 9910 Router Chassis Air Filter, on page 35</a> ).
Cisco ASR 9922 Router	Three air filters are located on the middle cage ( <a href="#">Figure 41: Cisco ASR 9922 Router Chassis Air Filters—Version 1, on page 35</a> ). The center air filter covers the front of the FC cards. <a href="#">Figure 42: Cisco ASR 9922 Router Chassis Air Filter—Version 2, on page 36</a> shows the version 2 center air filter. The side air filters cover the RP cards. <a href="#">Figure 44: Cisco ASR 9922 Router Chassis Side Air Filter—Versions 1 and 2, on page 37</a> shows how to replace the foam media inside one of the two side air filters.
Cisco ASR 9912 Router	Three air filters on the RP/FC card cage ( <a href="#">Figure 45: Cisco ASR 9912 Router Chassis Air Filters, on page 38</a> ). The center air filter covers the front of the FC cards. The side air filters cover the RP cards.

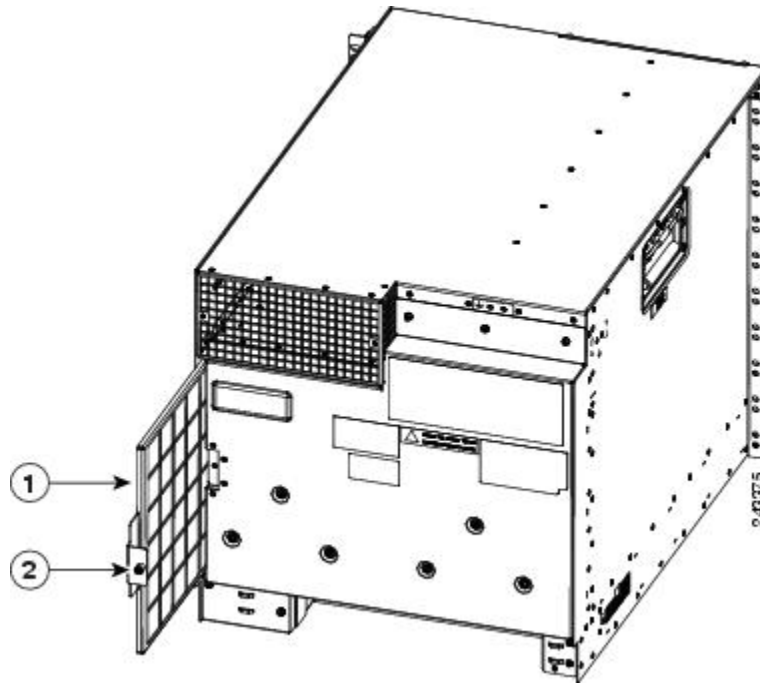


Figure 36: Cisco ASR 9010 Router Chassis Air Filter



2-432016

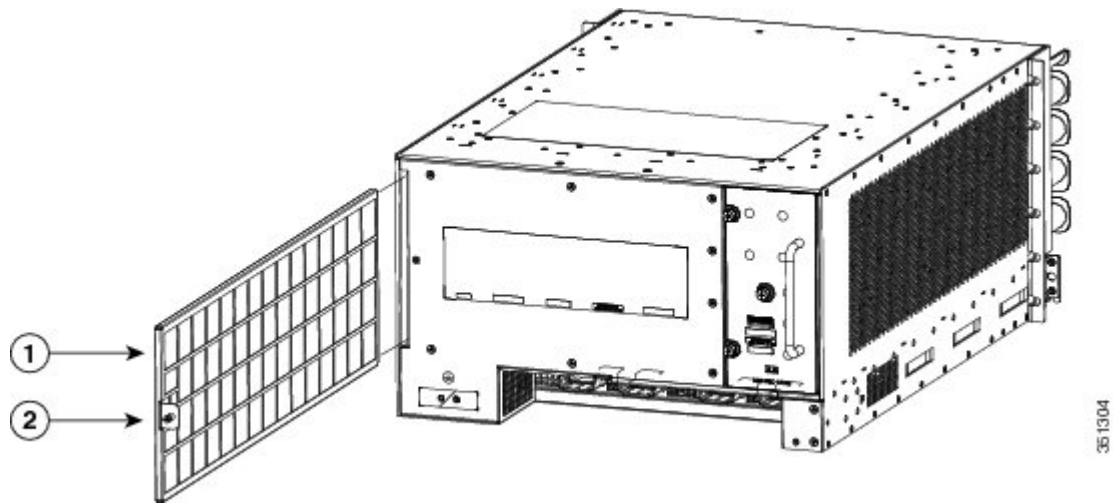
Figure 37: Cisco ASR 9006 Router Chassis Air Filter



2-433715

1	Air filter	2	Thumb screw
---	------------	---	-------------

Figure 38: Cisco ASR 9904 Router Air Filter



1	Air filter	2	Thumb screw
---	------------	---	-------------

Figure 39: Cisco ASR 9906 Router Chassis Air Filter

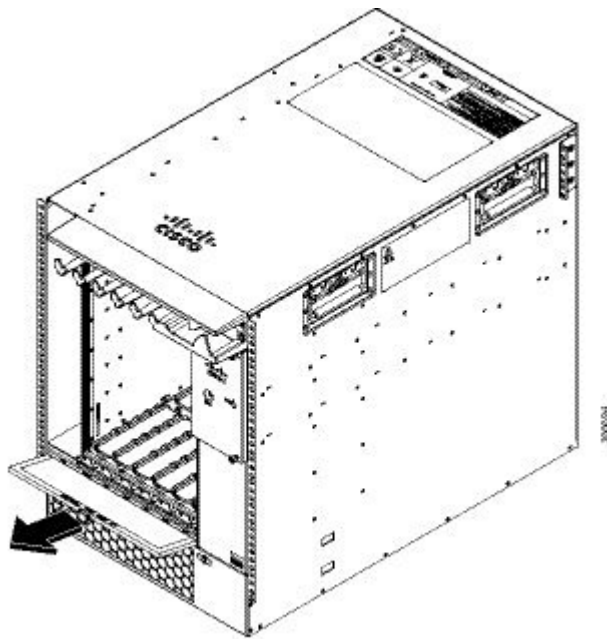


Figure 40: Cisco ASR 9910 Router Chassis Air Filter

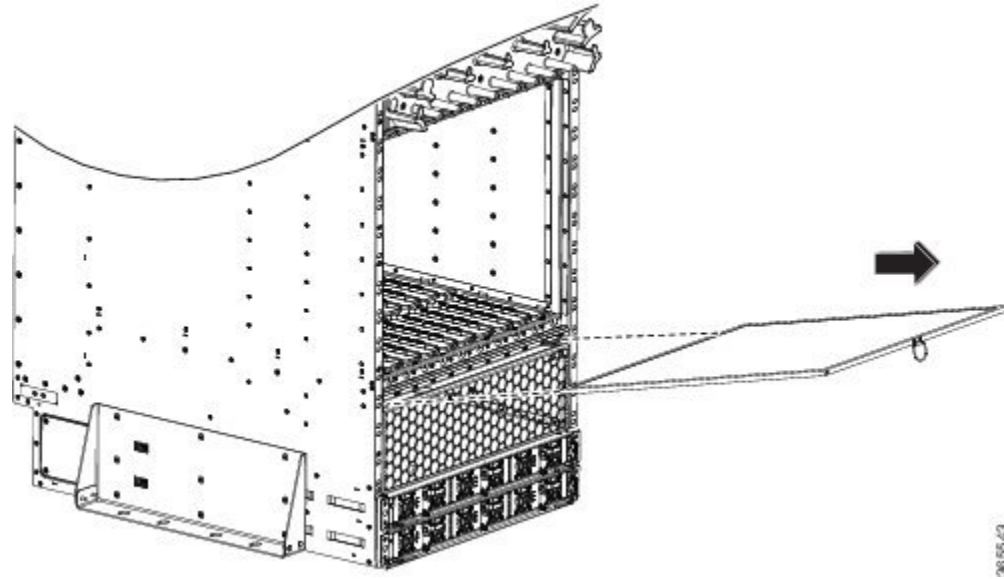


Figure 41: Cisco ASR 9922 Router Chassis Air Filters—Version 1

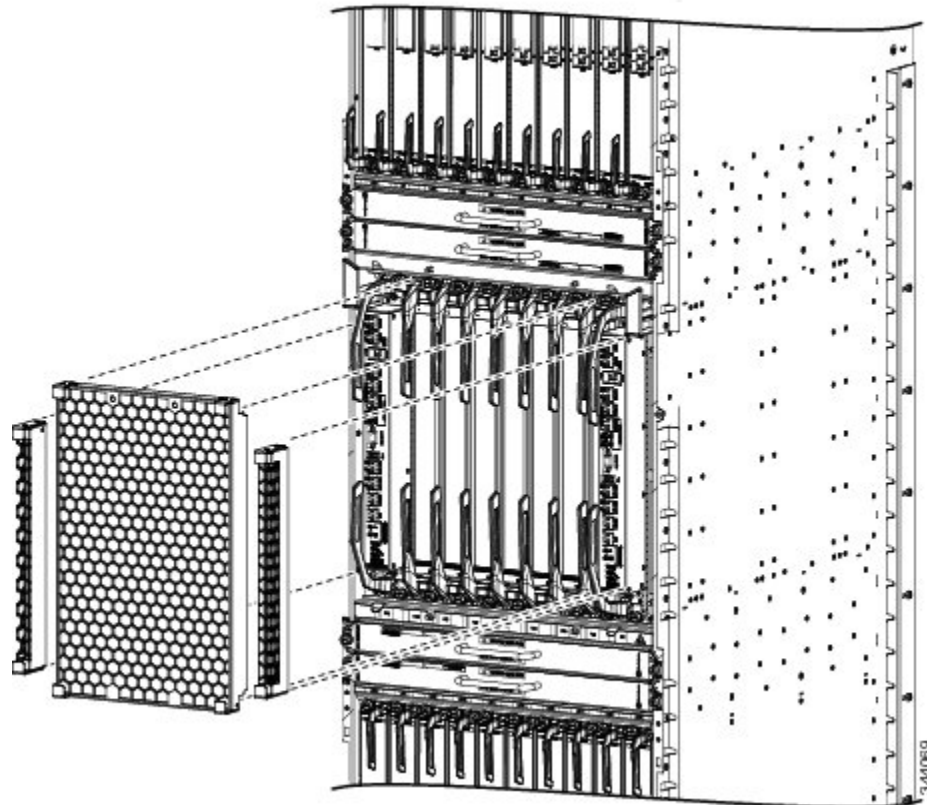


Figure 42: Cisco ASR 9922 Router Chassis Air Filter—Version 2

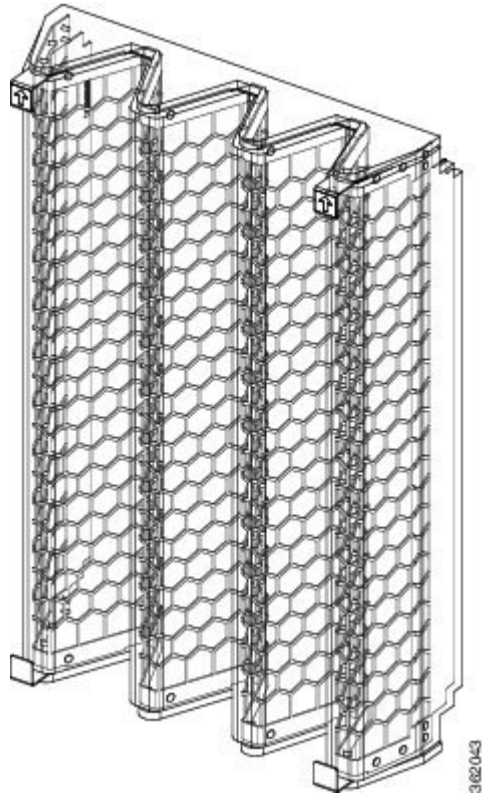
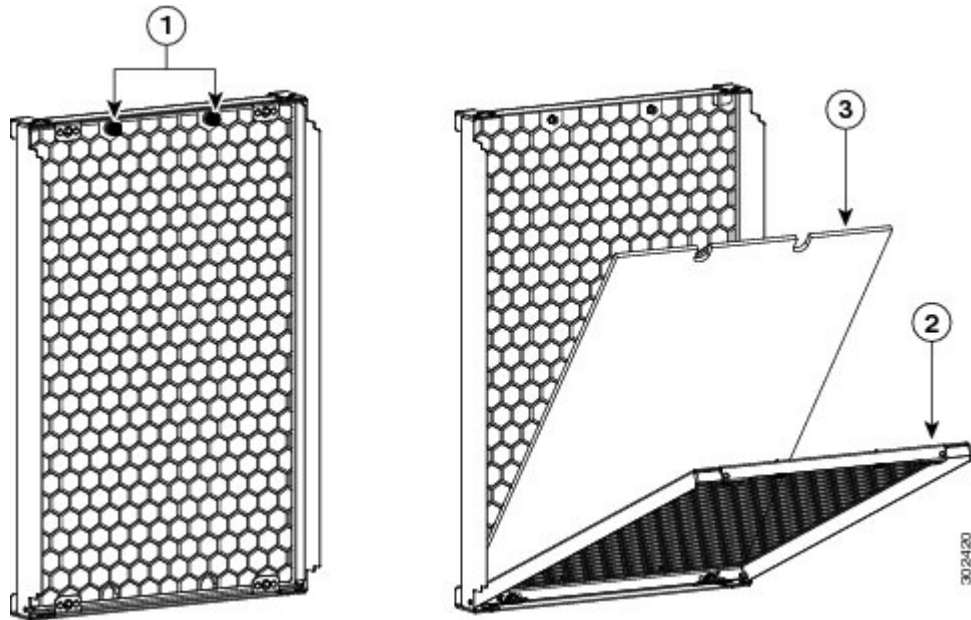


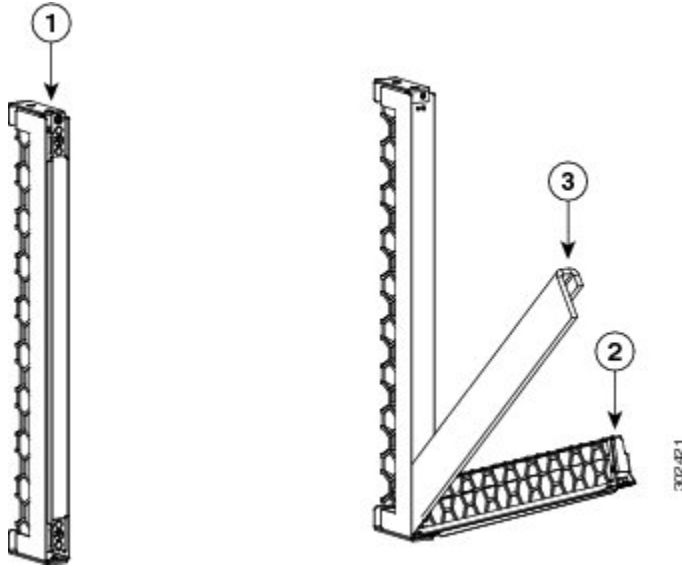
Figure 43: Cisco ASR 9922 Router Chassis Center Air Filter—Version 1



1	Loosen thumb screws	3	Remove foam filter media
---	---------------------	---	--------------------------

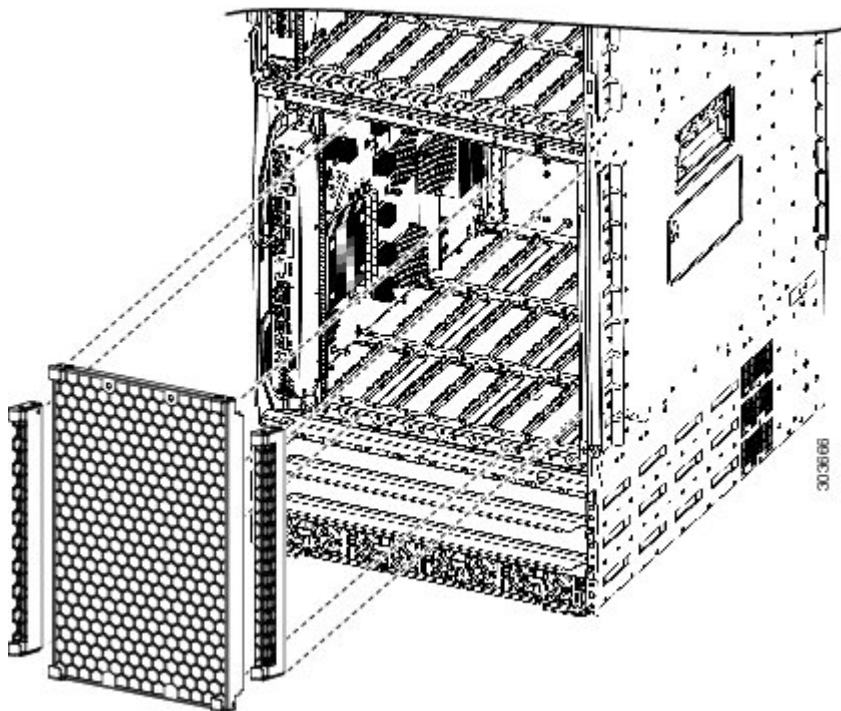
2	Rotate and lower inner frame		
---	------------------------------	--	--

Figure 44: Cisco ASR 9922 Router Chassis Side Air Filter—Versions 1 and 2



1	Loosen thumb screws	3	Remove foam filter media
2	Rotate and lower inner frame		

Figure 45: Cisco ASR 9912 Router Chassis Air Filters



## Speed Control

The cooling system adjusts its speed to compensate for changes in system or external ambient temperatures. To reduce operating noise, the fans have variable speeds. Speed can also vary depending on system configurations that affect total power dissipation. If lower power cards are installed, the system could run at slower speeds; if higher power cards are installed, the system could run at faster speeds.

Fan speed is managed by the RSP/RP card and the controller card in the fan tray. The RSP/RP monitors card temperatures and sends a fan speed to the controller card.

If the failure of a single fan within a module is detected, the failure causes an alarm and all the other fans in the fan tray go to full speed.



---

**Note** Complete failure of one fan tray causes the remaining fan tray to operate its fans at full speed continuously until a replacement fan tray is installed.

---

## Temperature Sensing and Monitoring

Temperature sensors are present on cards to monitor the internal temperatures. Line cards and RSP/RP cards have their leading edge (inlet) and hottest spot continuously monitored by temperature sensors. Some cards have additional sensors located near hot components that need monitoring. Some ASICs have internal diodes that might be used to read junction temperatures.

- If the ambient air temperature is within the normal operating range, the fans operate at the lowest speed possible to minimize noise & power consumption.
- If the air temperature in the card cage rises, fan speed increases to provide additional cooling air to the internal components. If a fan fails, the others increase in speed to compensate.

Fan tray removal triggers environmental alarms and increases the fan speed of the remaining tray to its maximum speed.

## Servicing

The system is populated with two fan trays for redundancy. If a fan tray failure occurs, it is possible to swap a single fan tray assembly while the system is operational. Assuming redundant configuration, removal of a fan tray results in zero packet loss.

Fan tray removal does not require removal of any cables.

## System Shutdown

When the system reaches critical operating temperature points, it triggers a shutdown sequence of the system.

# System Management and Configuration

The Cisco IOS XR Software on the ASR 9000 Series Routers provides the system manageability interfaces: CLI, XML, and SNMP.

## Cisco IOS XR Software

The ASR 9000 Series Routers run Cisco IOS XR Software and use the manageability architecture of that operating system, which includes CLI, XML, and SNMP. Craft Works Interface (CWI), a graphical craft tool for performance monitoring, is embedded with the Cisco IOS XR Software and can be downloaded through the HTTP protocol. However, the ASR 9000 Series Routers support only a subset of CWI functionality. In this mode, a user can edit the router configuration file, open Telnet/SSH application windows, and create user-defined applications.

## System Management Interfaces

The system management interfaces consist of the CLI, XML, and SNMP protocols. By default, only CLI on the console is enabled. When the management LAN port is configured, various services can be started and used by external clients, such as Telnet, SSH, and SNMP. In addition, TFTP and Syslog clients can interact with external servers. CWI can be downloaded and installed on a PC or Solaris box.

For information about SNMP, see [SNMP, on page 40](#).

All system management interfaces have fault and physical inventory.

## Command-Line Interface

The CLI supports configuration file upload and download through TFTP. The system supports generation of configuration output without any sensitive information such as passwords, keys, etc. The Cisco ASR 9000 Series Routers support Embedded Fault Manager (TCL-scripted policies) through CLI commands. The system also supports feature consistency between the CLI and SNMP management interfaces.

## Craft Works Interface

The system supports CWI, a graphical craft tool for performance monitoring, configuration editing, and configuration rollback. CWI is embedded with Cisco IOS XR software and can be downloaded through the HTTP protocol. A user can use CWI to edit the router configuration file, create user-defined applications, and open Telnet/SSH application windows to provide CLI access.

## XML

External (or XML) clients can programmatically access the configuration and operational data of the Cisco ASR 9000 Series Router using XML. The XML support includes retrieval of inventory, interfaces, alarms, and performance data. The system is capable of supporting 15 simultaneous XML/SSH sessions. The system supports alarms and event notifications over XML and also supports bulk PM retrieval and bulk alarms retrieval.

XML clients are provided with the hierarchy and possible contents of the objects that they can include in their XML requests (and can expect in the XML responses), documented in the form of an XML schema.

When the XML agent receives a request, it uses the XML Service Library to parse and process the request. The Library forwards the request to the Management Data API (MDA) Client Library, which retrieves data from the SysDB. The data returned to the XML Service Library is encoded as XML responses. The agent then processes and sends the responses back to the client as response parameter of the invoke method call. The alarm agent uses the same XML Service Library to notify external clients about configuration data changes and alarm conditions.

## SNMP

The SNMP interface allows management stations to retrieve data and to get traps. It does not allow setting anything in the system.

## SNMP Agent

In conformance with SMIV2 (Structure of Management Information Version 2) as noted in RFC 2580, the system supports SNMPv1, SNMPv2c, and SNMPv3 interfaces. The system supports feature consistency between the CLI and SNMP management interfaces.

The system is capable of supporting at least 10 SNMP trap destinations. Reliable SNMP Trap/Event handling is supported.

For SNMPv1 and SNMPv2c support, the system supports SNMP View to allow inclusion/exclusion of Miss for specific community strings. The SNMP interface allows the SNMP SET operation.

## MIBs

The Device Management MIBs supported by the ASR 9000 Series Routers are listed at:

<http://cisco.com/public/sw-center/netmgmt/cmtk/mibs.shtml>

## Online Diagnostics

System run-time diagnostics are used by the Cisco Technical Assistance Center (TAC) or the end user to troubleshoot a field problem and assess the state of a given system.



Some examples of the run-time diagnostics include the following:

- Monitoring line card to RSP/RP card communication paths
- Monitoring line card to RSP/RP card data path
- Monitoring CPU communication with various components on the line cards and RSP/RP cards

