



Le Nouvel Ethernet Operateur

Services et Applications pour  
l'Entreprise et le Résidentiel

Cisco Expo 2008

Alger, 27 Mai 2008



**Riadh Kassab – CCIE #9937**

**Systems Engineer, Cisco Systems**

# Agenda

- Market Overview and Key Trends
- IP NGN Carrier Ethernet — Architecture Overview
- IP NGN Carrier Ethernet - Product Portfolio
- Metro Ethernet Services Opportunities
- Q&A



# Market Overview and Key Trends

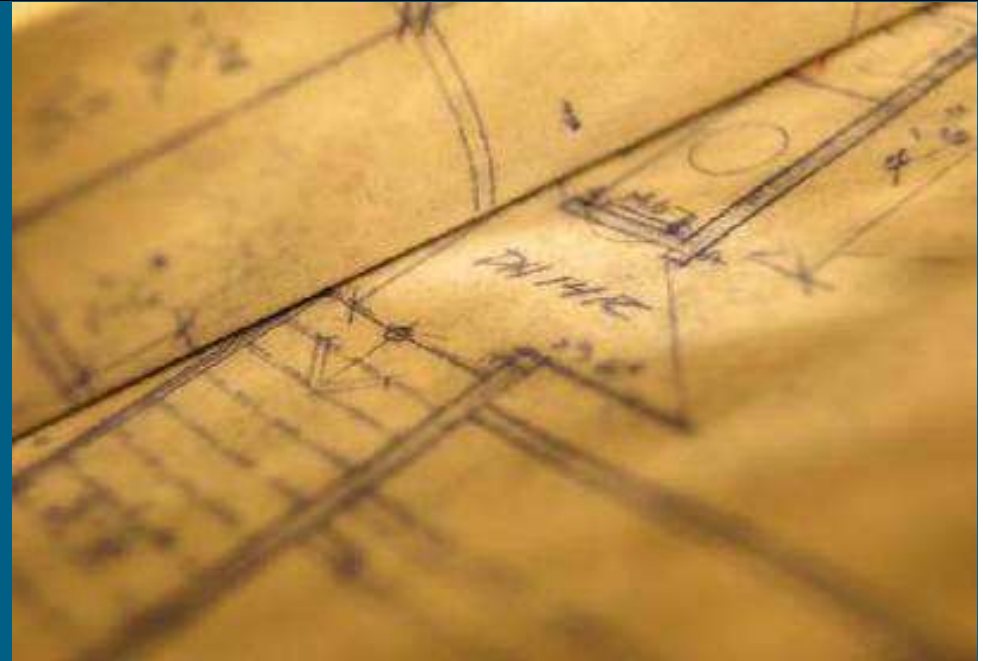

# Cisco Service Provider Vision

Connecting Customers with Services,  
Services with Networks,  
and Networks with Each Other



## IP Next-Generation Network



VPNs



Content



Transport



Mobility



Internet



Voice &  
Video

# Residential Bandwidth Demand

## Personalized Experiences to Many Screens



# Applications Moving From LAN to WAN Driving New WAN Requirements

**E-Commerce**



**Distributed  
Web-Based  
Applications**

**On-Demand  
Computing**



**Utility Computing  
Out-tasking**



**Data Replication  
Remote Backups**

**Workforce  
Optimization**



**Multimedia  
collaboration  
IP Communications**



**Enterprise  
Extranets**

*Scalable Metro Bandwidth*

*Flexibility*

*Simplicity*

# Four Key Connected Life Enablers



## Internet Protocol

Information becomes

**Agnostic to Content**



## Bandwidth

Information becomes

**Agnostic to Time**



## Connectivity

Information becomes

**Agnostic to Space**



## Quality of Experience

Information becomes

**Agnostic to Form**

# Service Provider Needs

## To Make the Experience Provider Transition

### Services

Differentiation  
Loyalty  
Revenue

### Efficiencies

OPEX  
CAPEX  
Profits

### Control

Service  
Network  
Business

### IP

Intelligence  
Flexibility  
Adaptability

# Cisco IP NGN Framework

## Cisco is The Leader in IP Networking

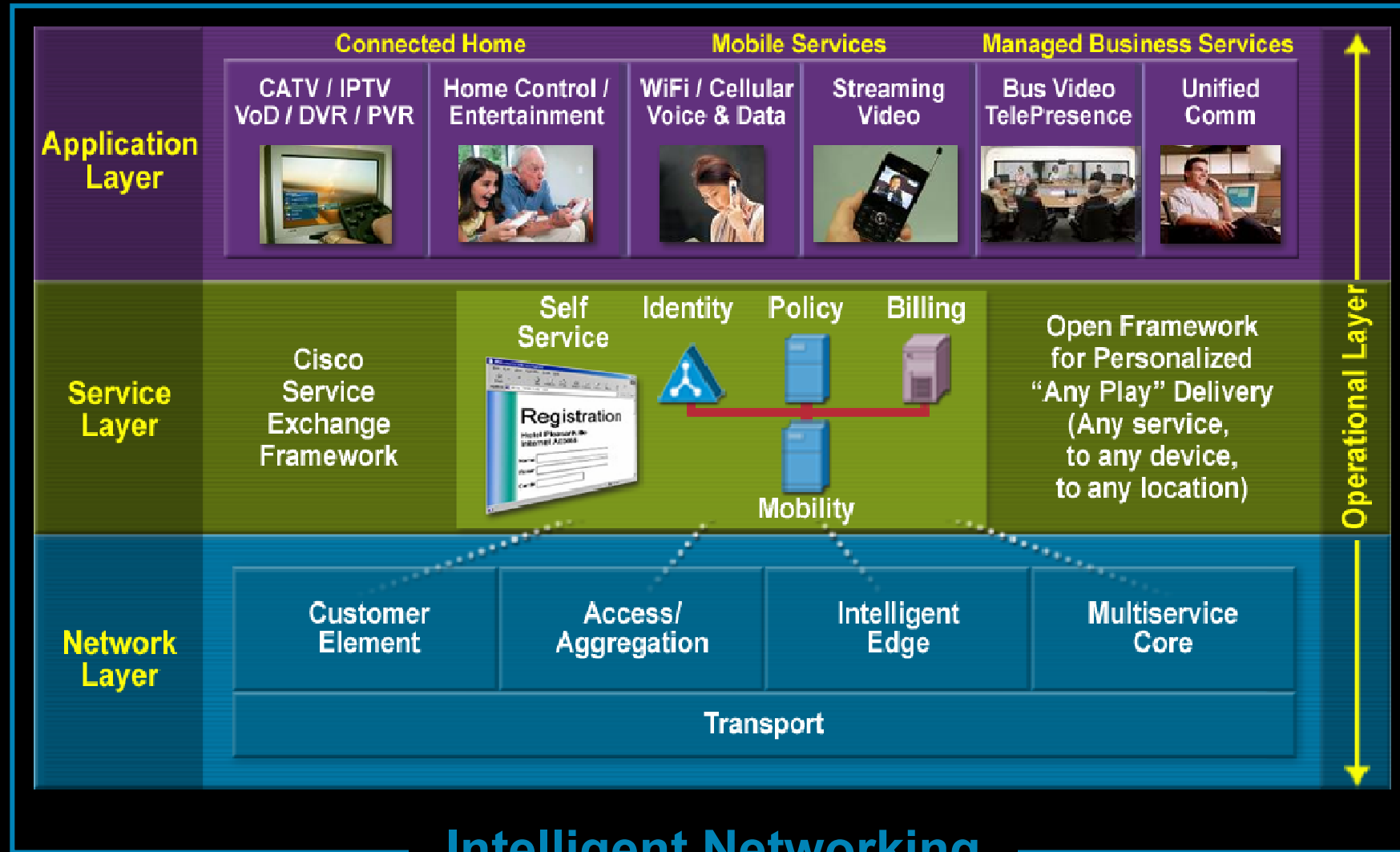

# IP NGN Carrier Ethernet—Architecture Overview

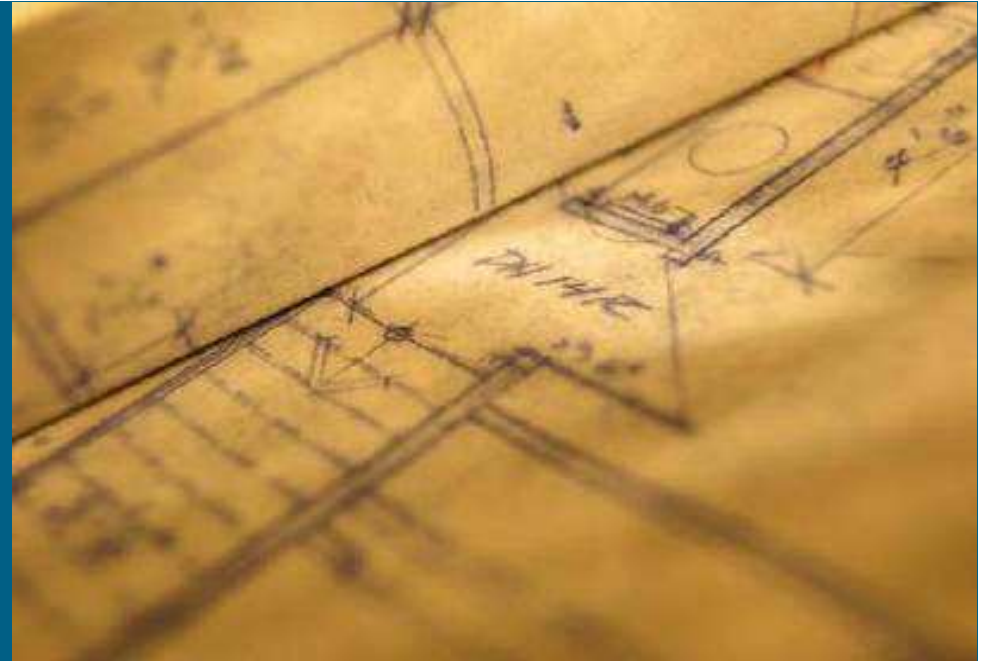

## Why Ethernet?: Simplicity

- Significantly Reduction of Unnecessary Equipment Layers
- Lowers equipment cost
- Lowers operational cost
- Lowers complexity
- Simplifies architecture

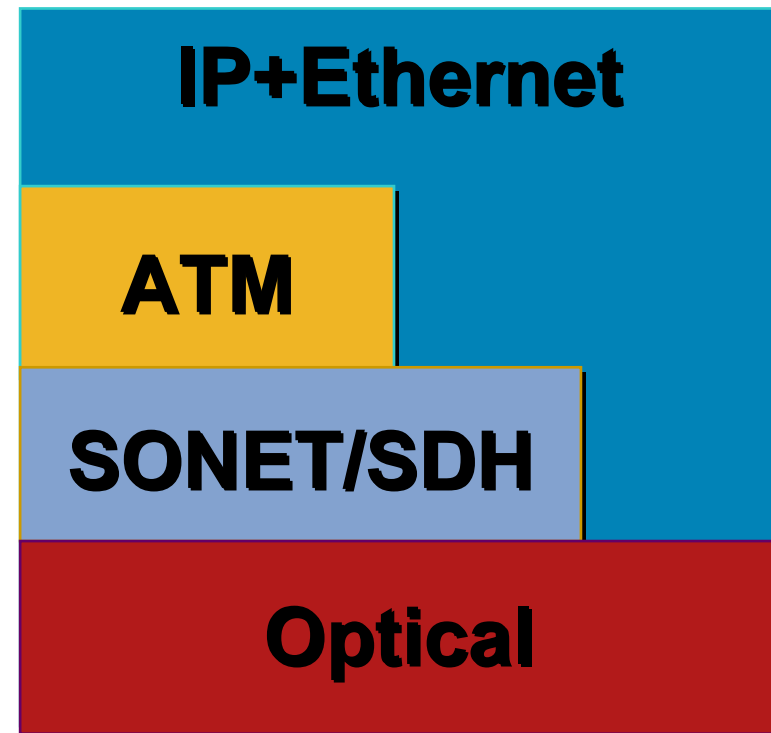

# IP NGN Carrier Ethernet

## A Better Experience: The Connected Life



Architectural Framework and Functionality

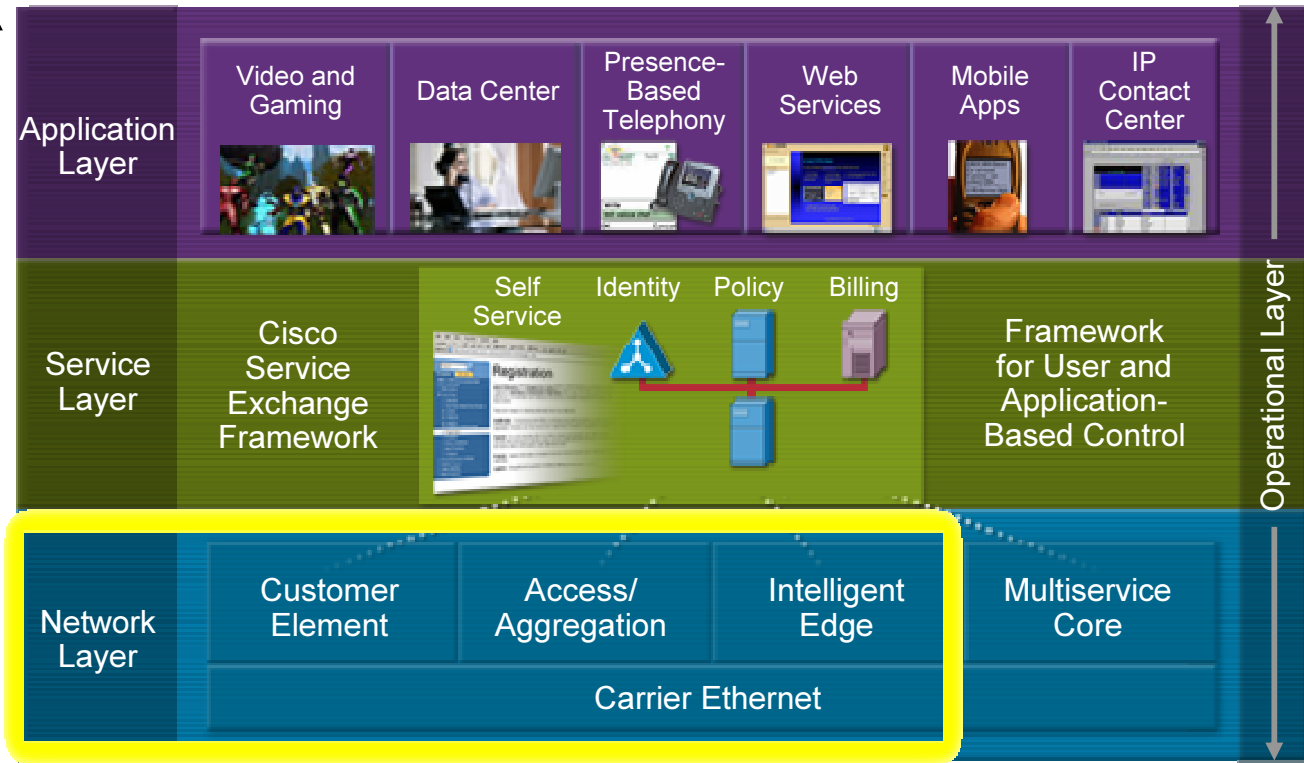

IP NGN

Network Layer

Physical Instantiation

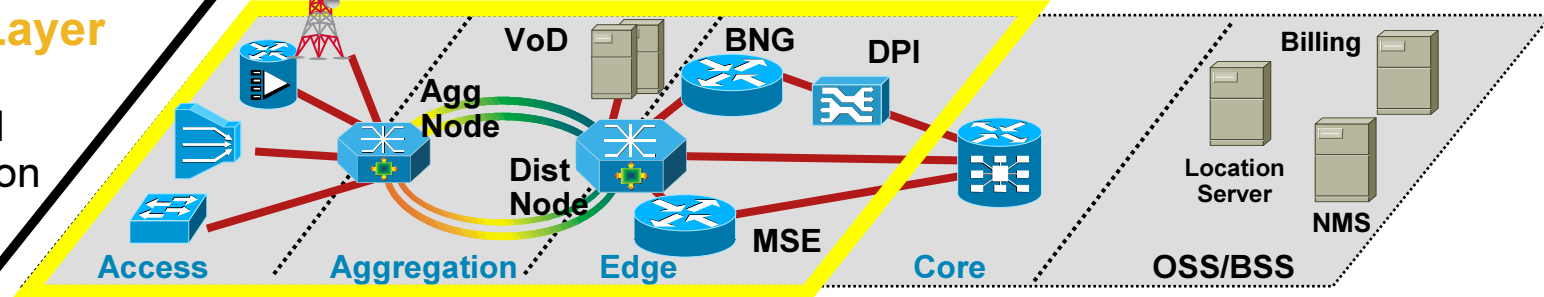

# IP NGN Carrier Ethernet 4.5

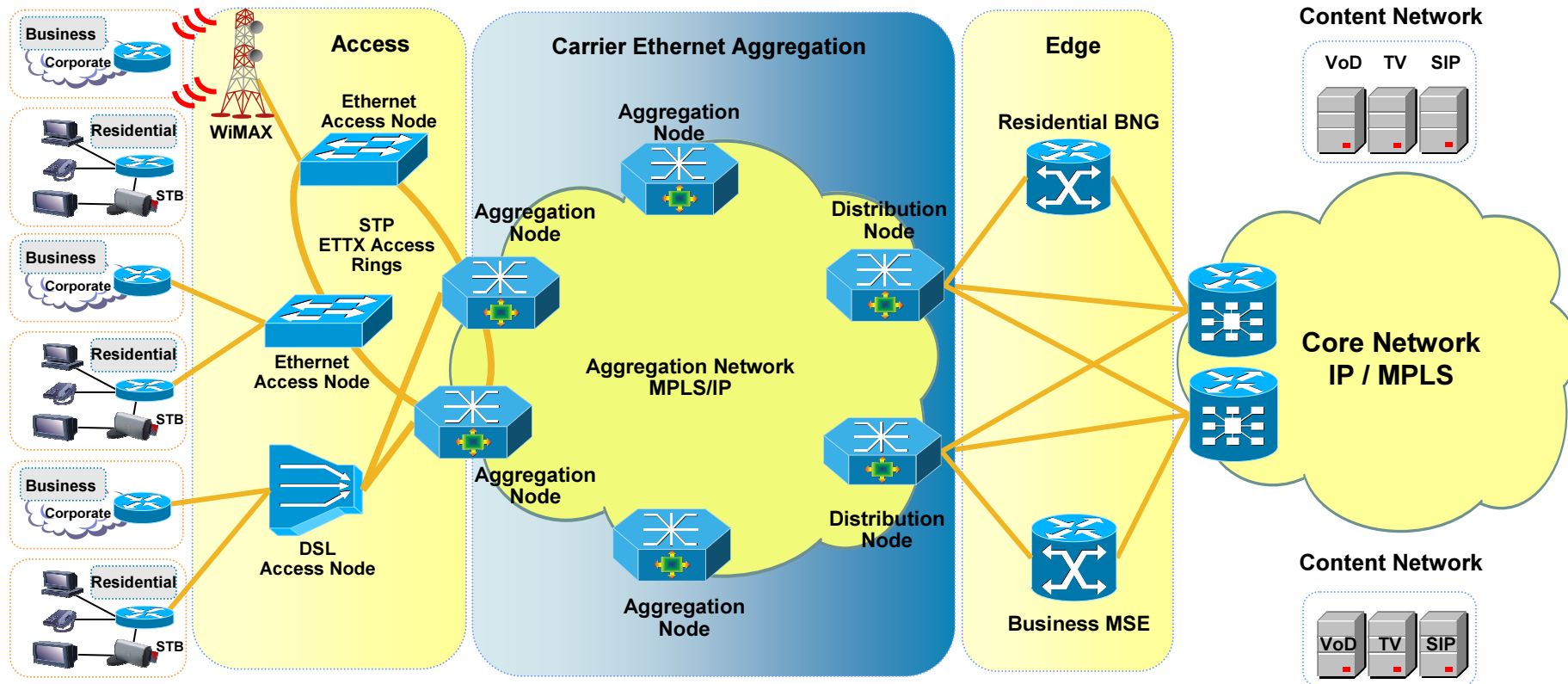
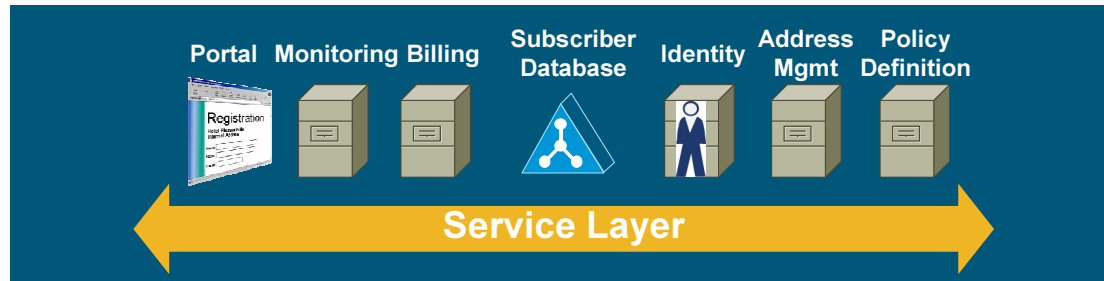

End-to-End System Validated

# IP NGN Carrier Ethernet

## Service-Optimized Transport Vs. One Size Fits All

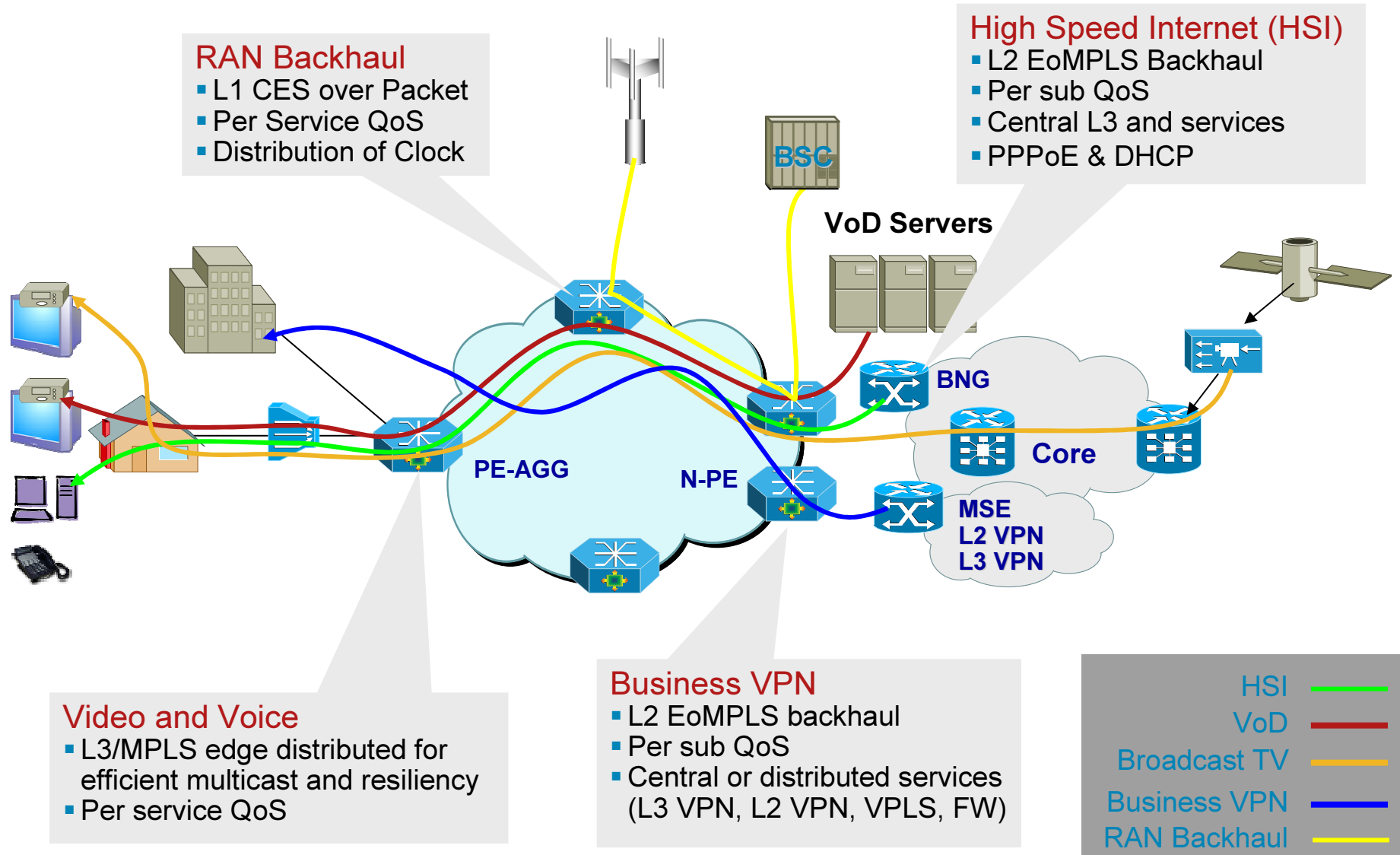

# Metro Ethernet Connectivity Services Framework

Services  
Overview

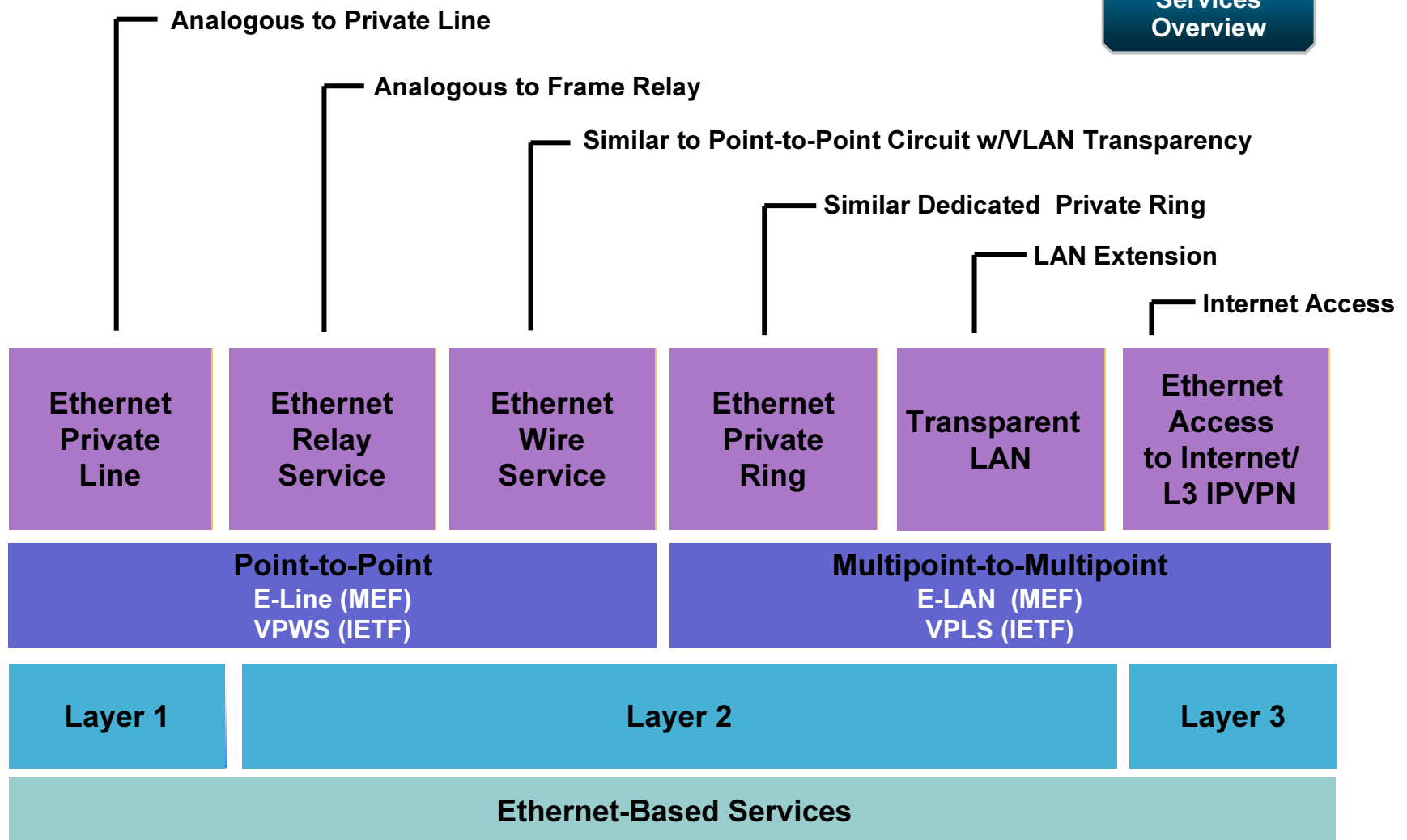

# HSI Implementation Construct

## Key Take Away

- EVC Infrastructure
- EoMPLS PW, Single PW per AGG node
- Selective QiQ
- Converged architecture for residential and business services

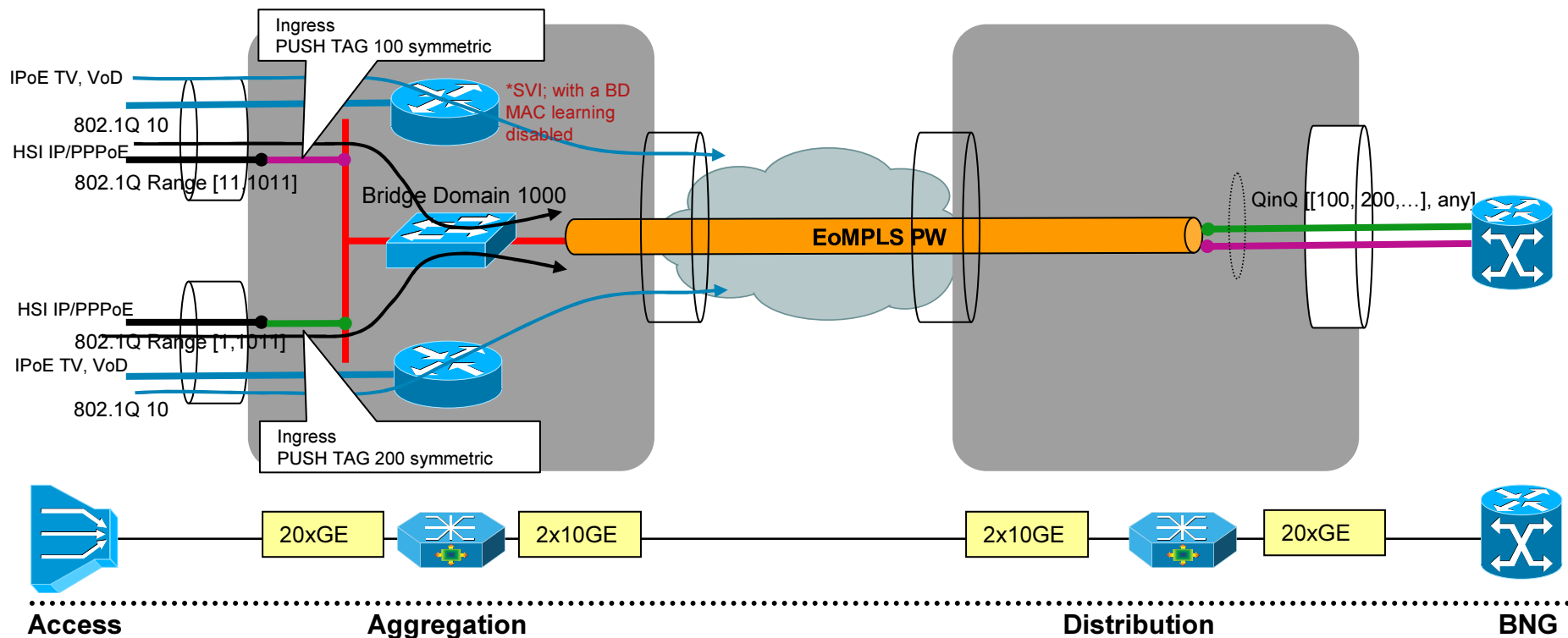

# Broadcast TV Service Construct

## Non-Stop Ethernet Service

Residential Services

- Multicast and Unicast Control Planes run separate routing topology
  - MTR or separate IGP
- Multicast Data Plane over PWs with MPLS TE-FRR link protection
  - Link failure has no impact on the PIM control plane
  - Data Plane fast re-convergence (<50ms)
- Agg Node failures addressed by PIM fast convergence
  - Should converge in less than 300 ms with 500 groups

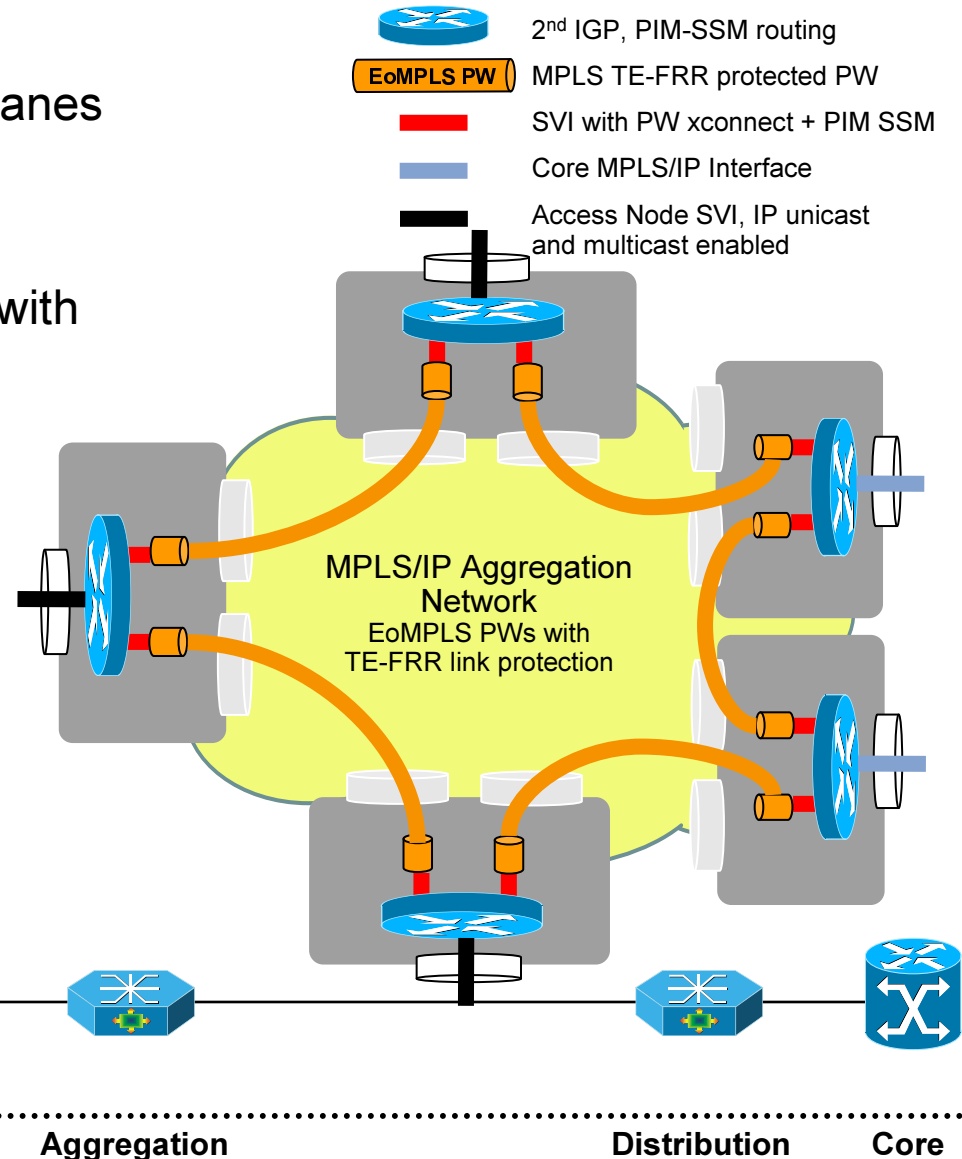

# L3 VPN Service Construct

## Key Take Away

- EVC Infrastructure
- EoMPLS PW per business customer (1:1 VLAN Map)
- Centralized or distributed MSE
- Converged architecture for residential and business services

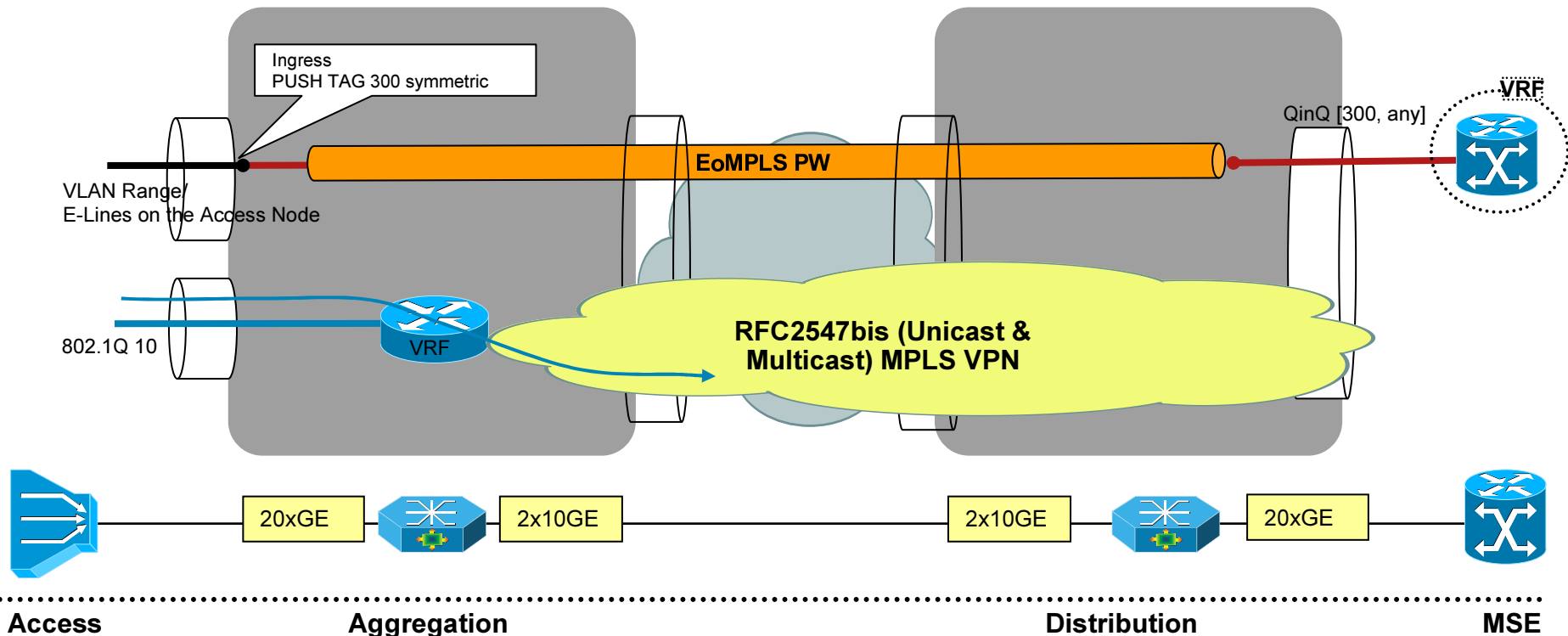

# E-Line Service Construct

## Key Take Away

- EVC Infrastructure
- Multiple flavors of point-to-point service instance (Port, VLAN, range, QiQ)
- EoMPLS PW per service instance or access node
- Converged architecture for residential and business services

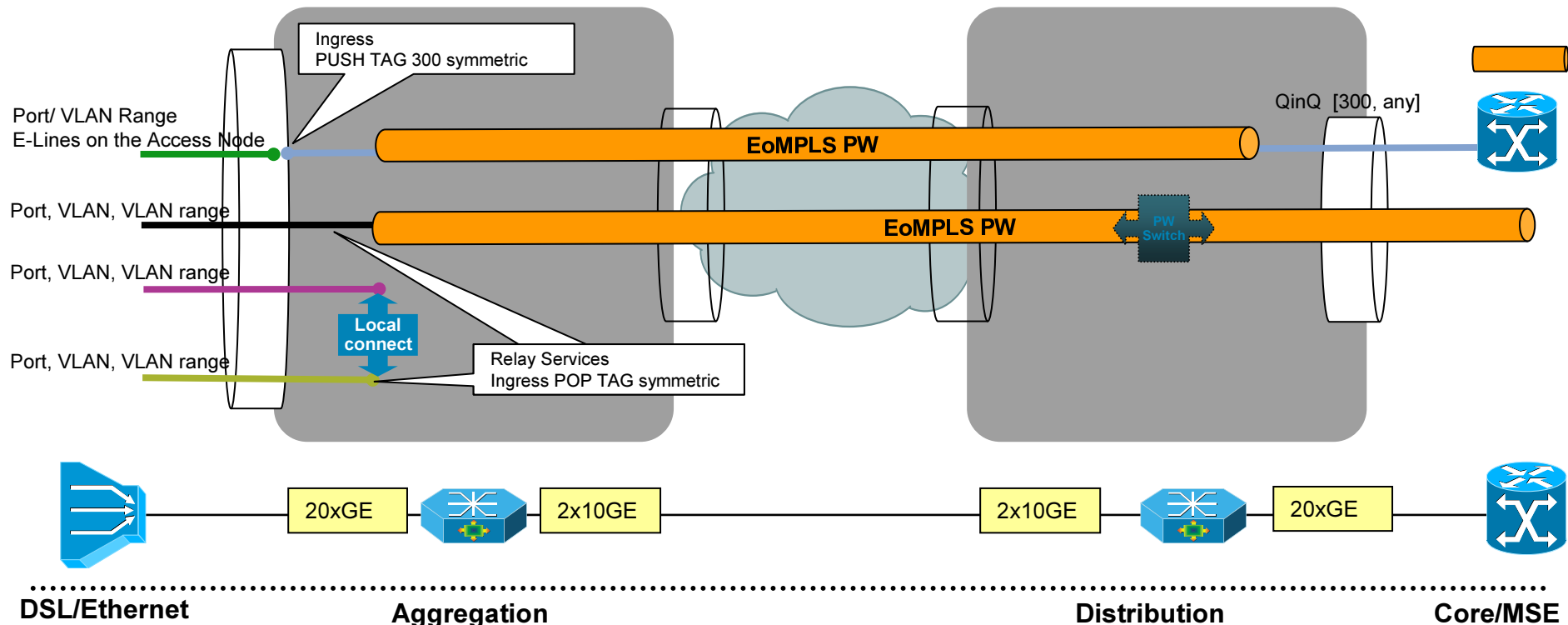

# E-LAN Service Construct

## Key Take Away

- EVC Infrastructure
- Only use-case for H-VPLS construct
- VFI Implemented either in the distribution node or the MSE
- Converged architecture for residential and business services

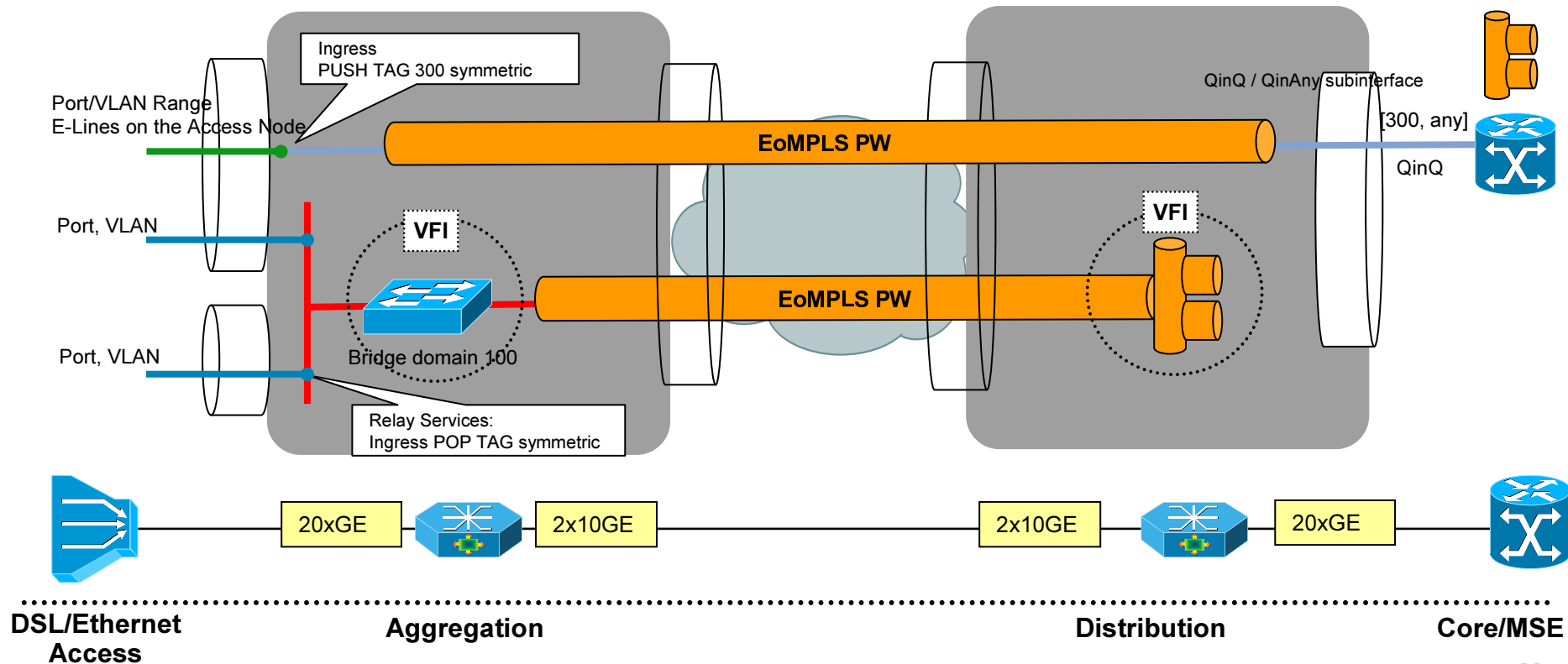

# IP NGN Carrier Ethernet Access — E-FTTH

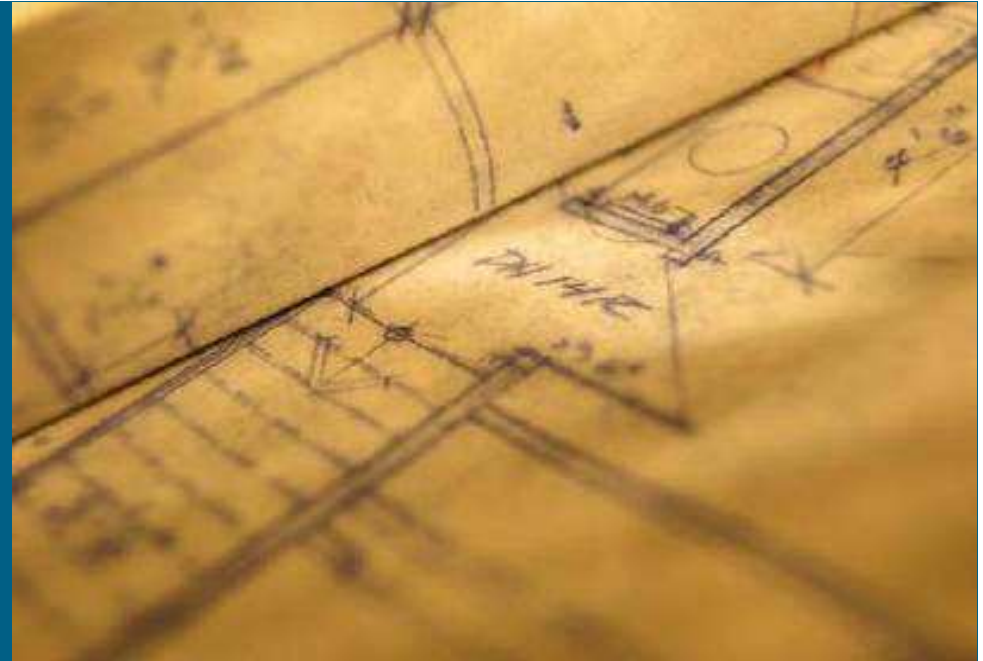

# ETT<sub>x</sub>

## Ethernet To The Home/Business



Objective of bringing Ethernet in the First Mile to deliver **Data, Voice, Video (triple play)** over a simple and inexpensive **Ethernet** network.

The unique aspect of this solution is the use of Ethernet as a means to provide **10/100/1000 Mbps Symmetric, cost efficient, access directly** to homes and businesses

# ETTx: two important markets

- **Ethernet to the Business (ETTB)**

Applications: LAN interconnection, Internet access, Remote access

End Customer needs more than E1

Requires SLA's and QoS

- **Ethernet to the Subscriber / Home (ETTS)**

Applications: Internet access, Teleworking, Gaming, Video, Voice

Complementary to DSL/cable

Includes Ethernet to the Subscriber (ETTS), and mixed residential/SMB environments

Low cost per UNI is critical

100,000s of customers in a metro network

# Two Access Options: Layer 2 Rings and Layer 2 Star

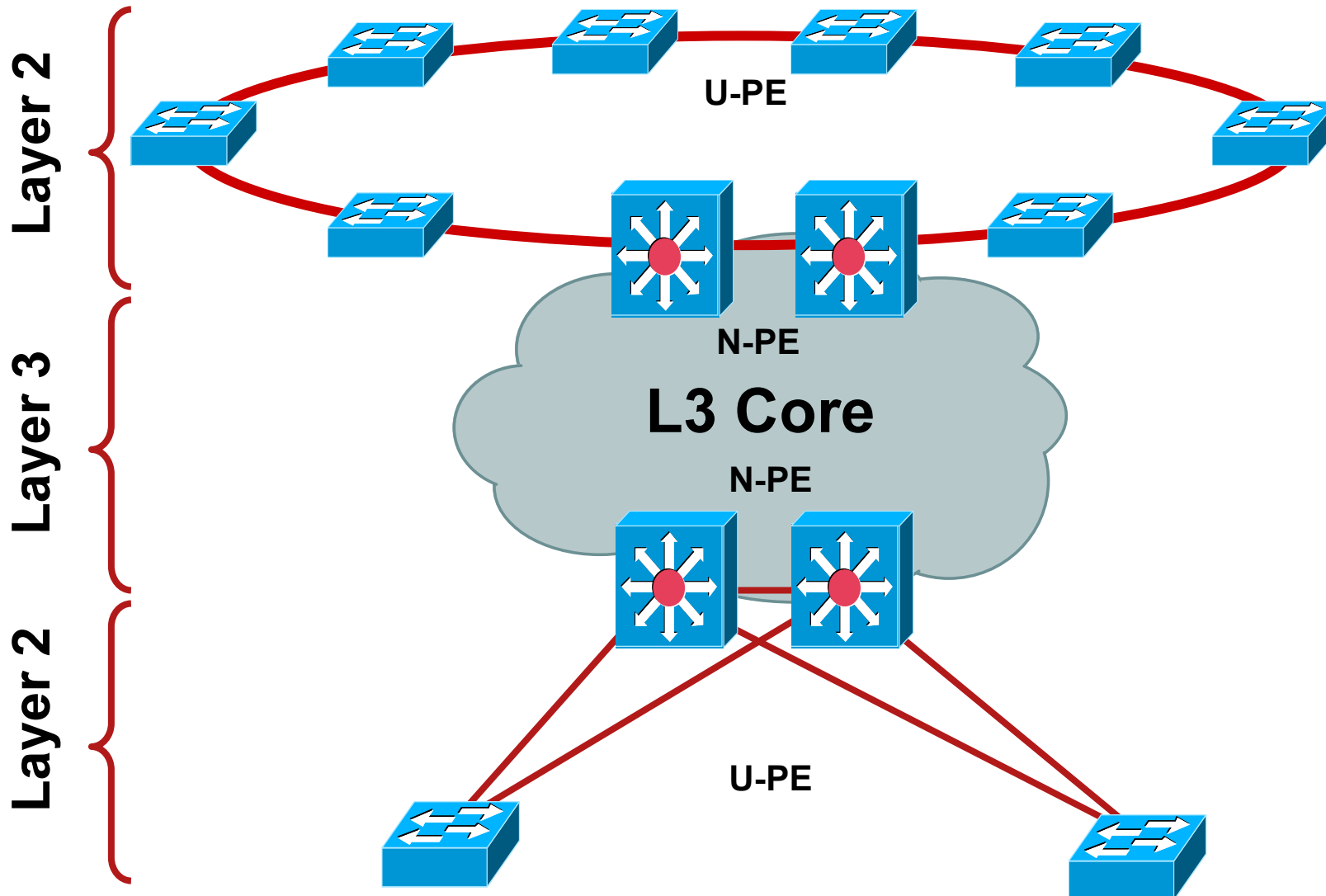



# High Availability



# Baseline Network Availability Mechanism

## IP Services:

- Fast IGP/BFD convergence
- Multicast Fast Convergence

## MPLS Services:

- Pseudowire redundancy
- MPLS TE-FRR Link and Node protection with IP services, PW/VPLS PW tunnel selection

MPLS/IP Services use a combination of MPLS TE-FRR and fast IGP/PIM convergence

*Note: Diffserv-RSVP for VoD CAC and RSVP-TE for MPLS FRR are mutually exclusive*

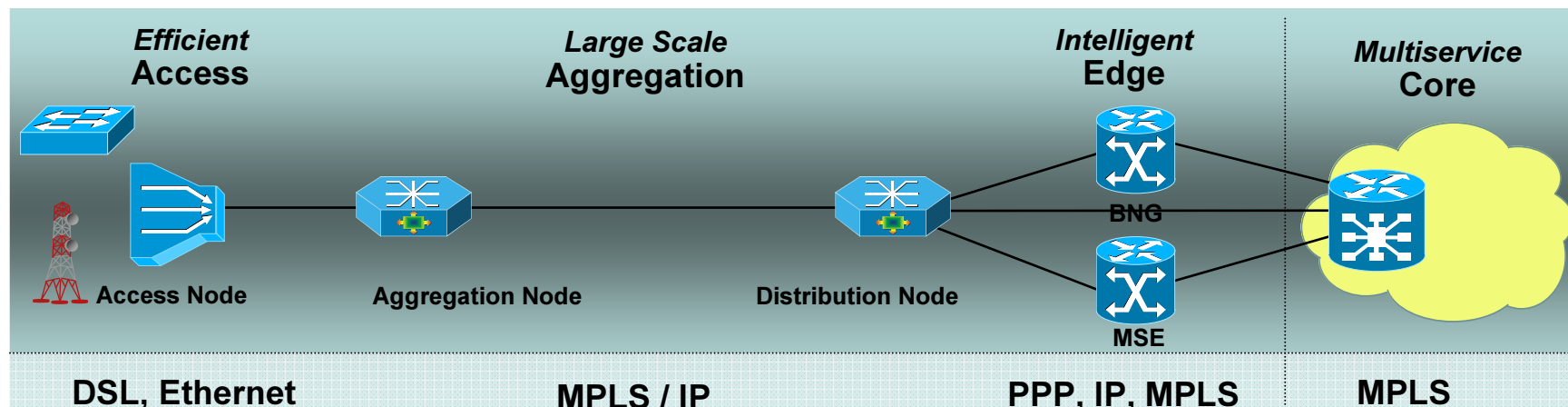



# Quality of Service



# QoS Architecture Direction

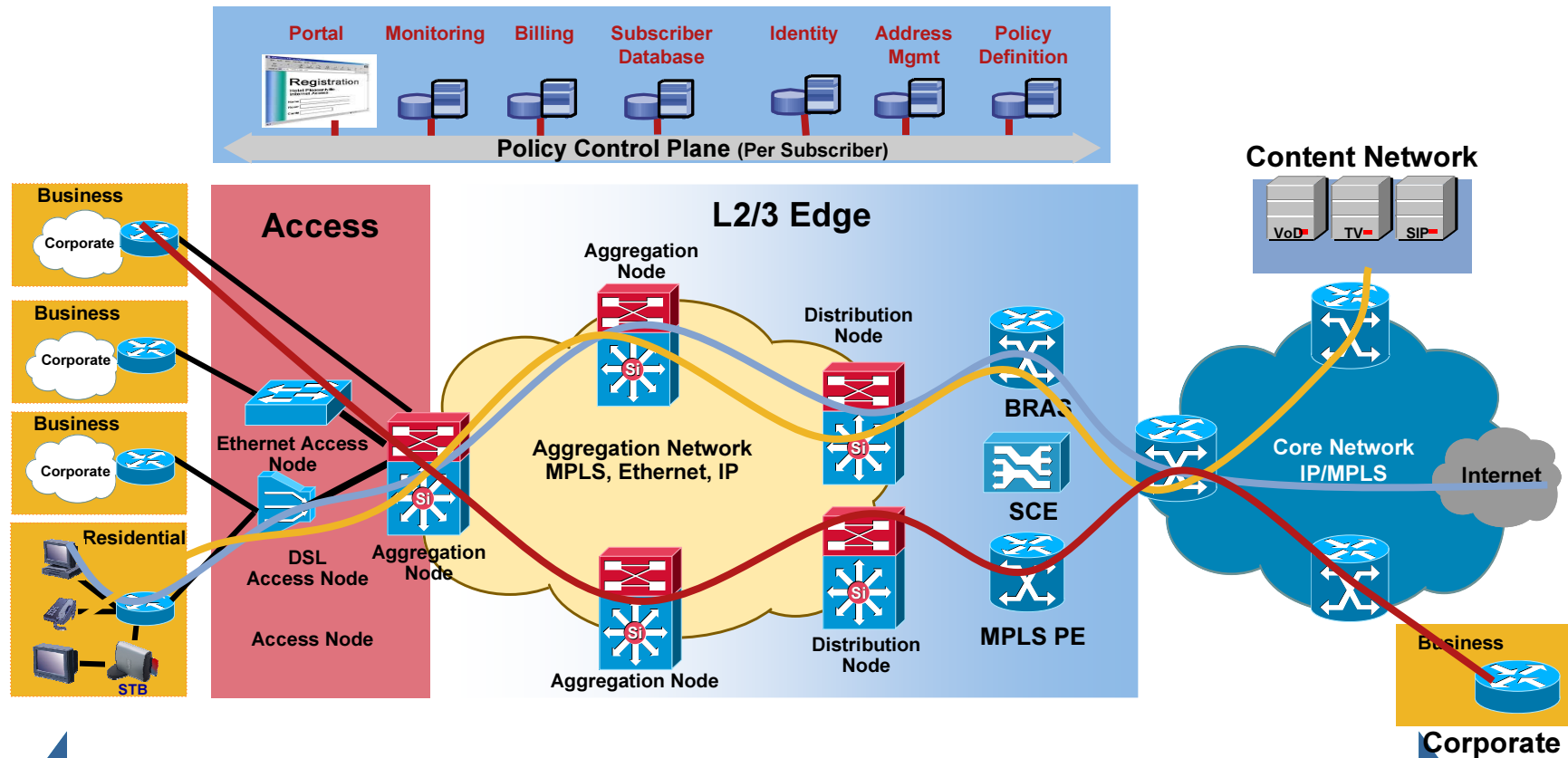

**Consumer and Business Traffic Utilize Per-Subscriber or Per Service QoS Model in Access, Aggregation and Core**

# Differentiated Services QOS Domain

Traffic Class	Core /Edge/ Aggregation			Access	UNI		
	MPLS/IP			Ethernet	DSL, ETTX	DSL	WIMAX
	PHB	DSCP	MPLS EXP	802.1P	802.1P	ATM	802.16
Control Protocols Network Management	AF	48	6	(6)	(6)	VBR-nrt	nrtPS
Residential Voice	EF	46	5	5 and 7	5 or 7	VBR-rt	rtPS
Business Real-time	EF	56	7				
Residential TV and VoD	AF	32	4	4 and 3	4	VBR-nrt	NA
Residential D-Server Video	AF	24	3				
Business Critical In Contract Business Critical Out of Contract	AF	16 8	2 1	2 and 1	2 1	VBR-nrt	nrtPS
Residential HSI Business Best Effort	BE	0	0	0	0	UBR	Best Effort



## Operations, Administration, and Maintenance (OAM)



# Ethernet OAM – Problem Taxonomy

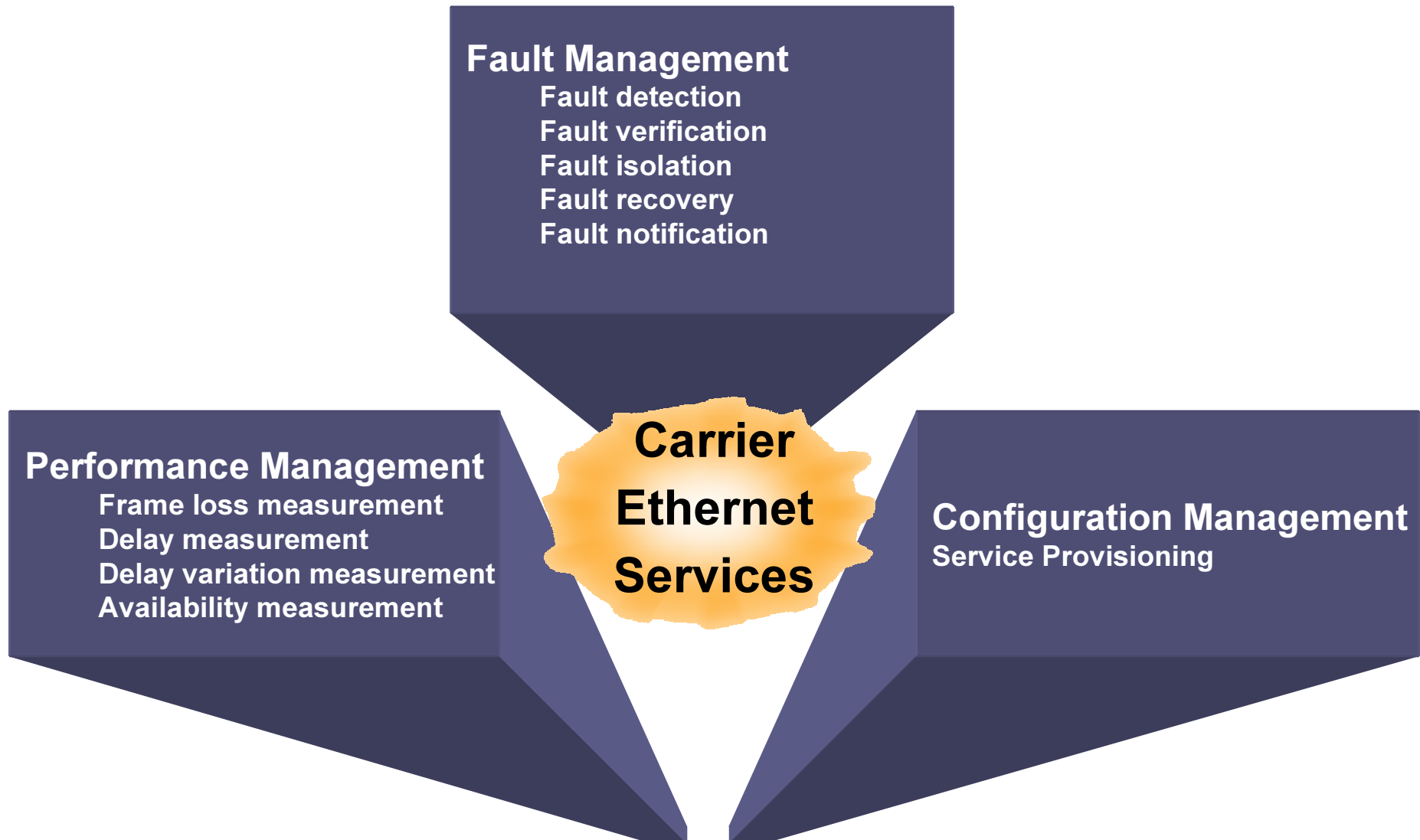

# Ethernet OAM – The Building Blocks

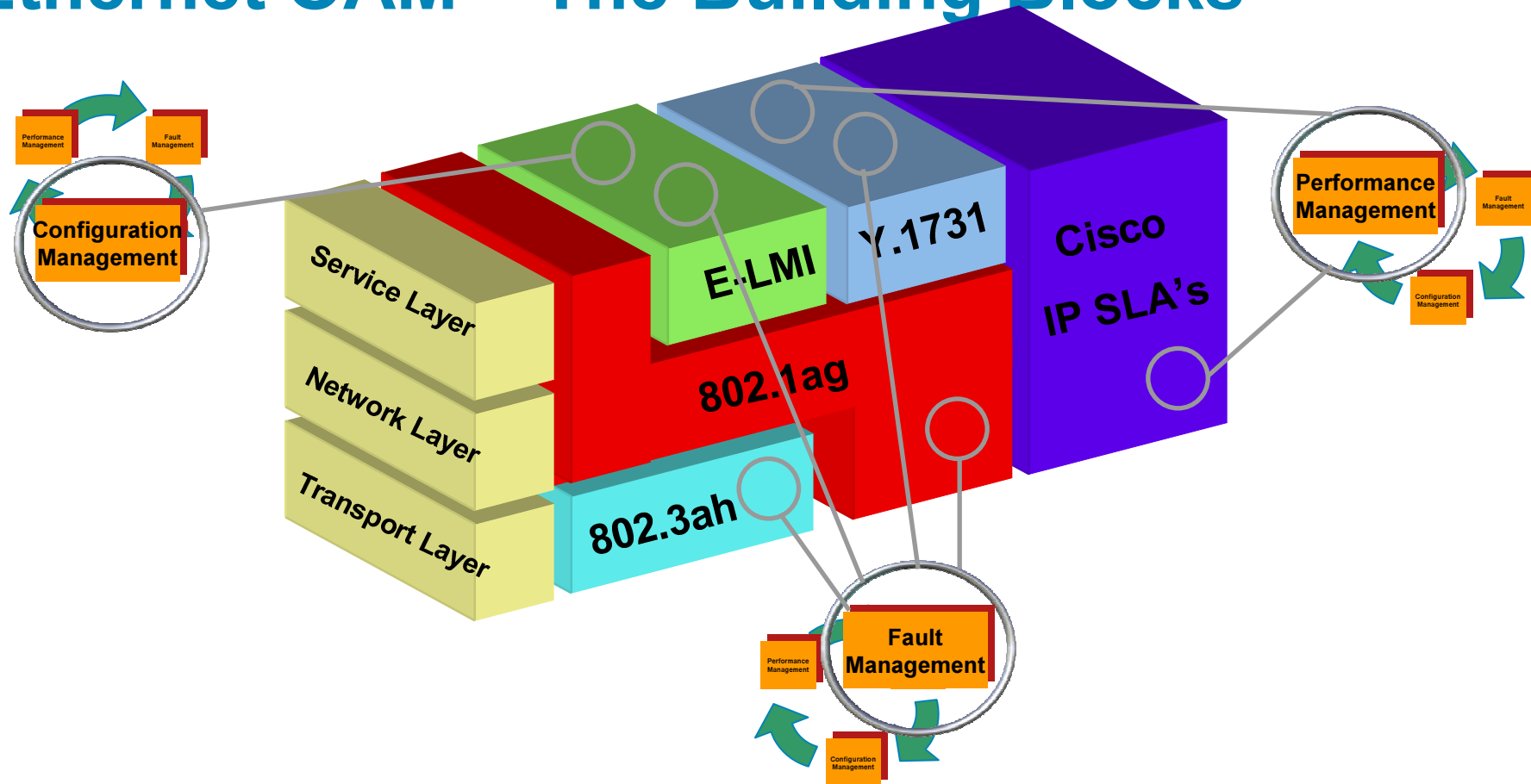

- IEEE 802.1ag: Connectivity Fault Management (CFM)
- ITU-T Y.1731: OAM functions and mechanisms for Ethernet based networks
- IEEE 802.3ah: Ethernet Link OAM (EFM OAM)
- MEF E-LMI: Ethernet Local Management Interface
- Cisco IP SLA's: Performance Management using IP, CFM and Y.1731 Mechanisms

# Ethernet OAM – Where they play

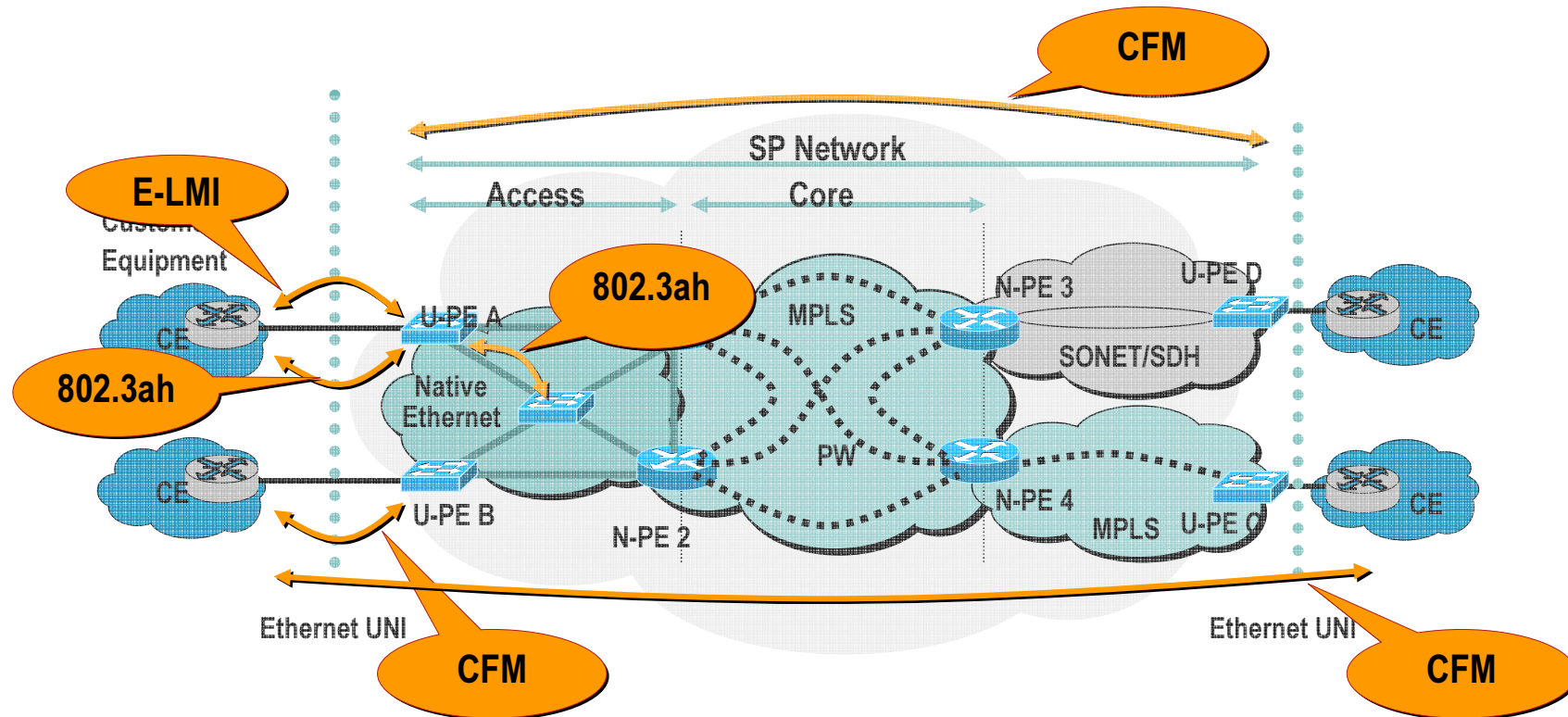

- Choice of protocols, their locality & span of operation varies with network topology & services – many variations possible
- Restrictions (inherent to protocol definitions):
  - E-LMI on UNI (uPE to CE)
  - 802.3ah on pt-to-pt (emulated ok) 802.3 PHY
  - CFM/Y.1731 require Ethernet MAC Layer awareness

# Business VPN Services: Customer View

## Business Ethernet

- End-to-end Ethernet solution, including ISR
- 802.1ag, 802.3ah for Ethernet SLAs
- Auto-provision w/E-LMI for time to service
- OAM supports ATM/FR to Carrier Ethernet migration

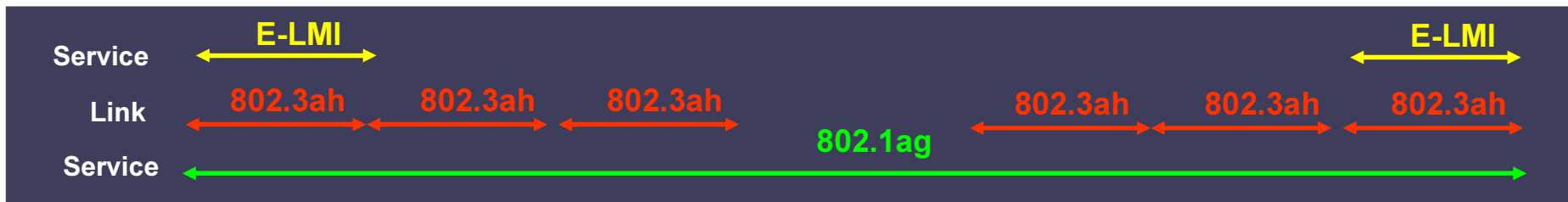
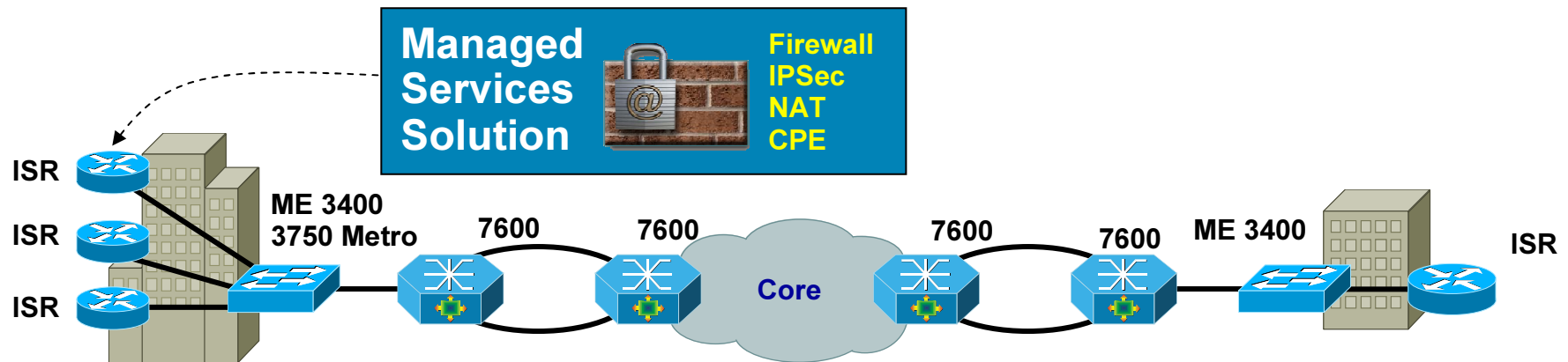



## Security Considerations



# Carrier Ethernet – New EVC Model

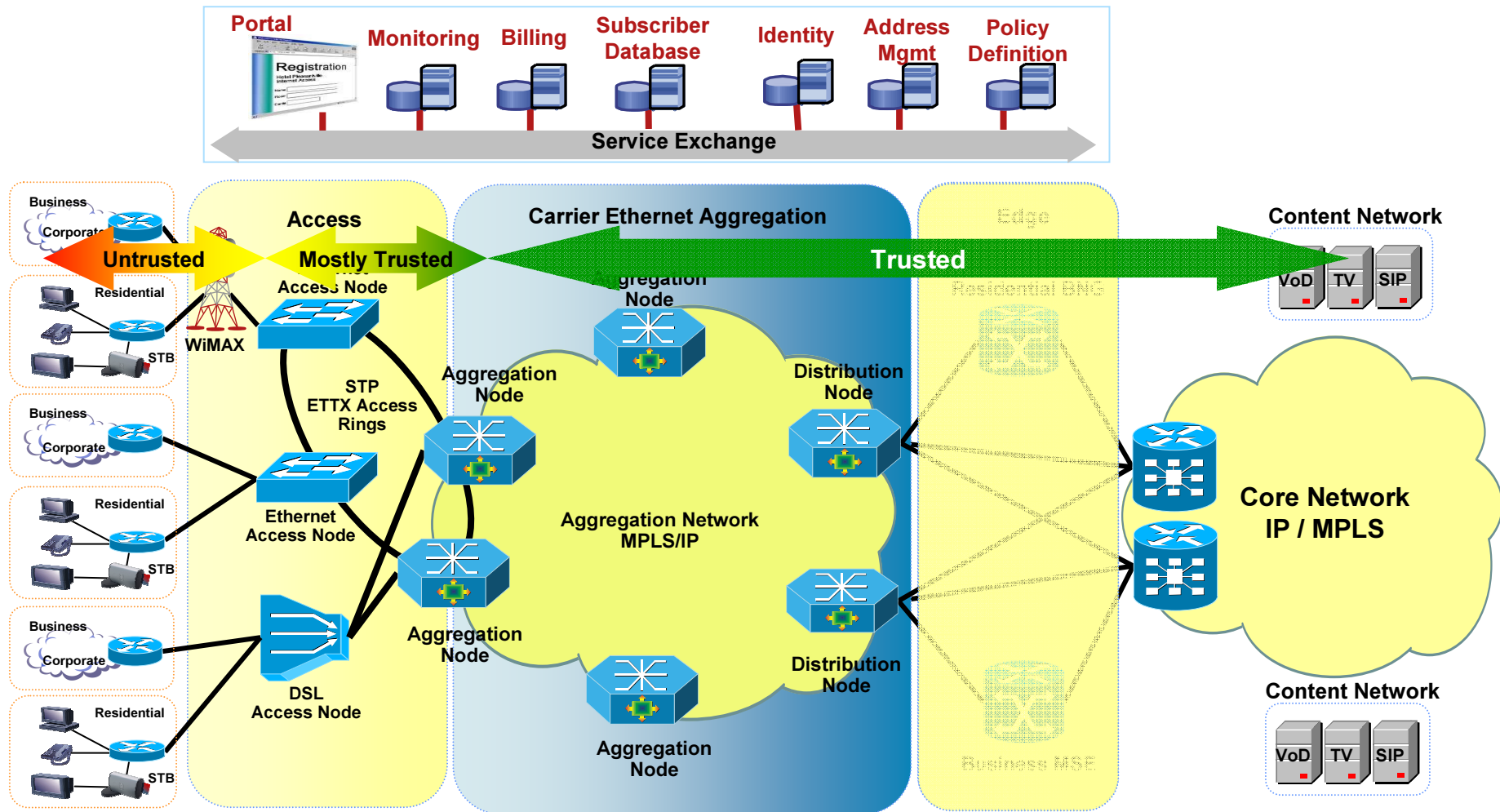

# Attacks and Defensive Features/Actions

Attack	Switchport Defensive Actions	EVC Defensive Actions
MAC Address (CAM Table Overflow)	Port Security, Per VLAN MAC Limiting	Per VLAN MAC-Limiting (Per EVC in future release)
Broadcast/ Multicast Storms	Storm Control	Effect limited to Bridge-Domain (Storm Control in future release)
VLAN Hopping / DTP	Disable Auto-trunking, Dedicated VLAN-ID for Trunk Ports, Set User Ports to Non-trunking, VLAN 1 Minimization, Disable Unused Ports.	Layer 2 Split-Horizon
Spanning Tree	BPDU Guard, Root Guard, MD5 VTP Authentication	Spanning Tree not enabled. BPDUs can be dropped or tunneled.
DHCP Rogue Server	DHCP Snooping (Differentiate Trusted and Untrusted Ports). Dynamic ARP Inspection	
Hijack Management	Use Encrypted Access (SSH, not Telnet), OOB Management, Disable Password Recovery, Encrypted Passwords	

# Common Security Recommendations

## How to Secure the Network Against Attacks

Leading Practice Category	Examples	Protects against threats
Disable Unnecessary Services	ICMP redirects, CDP, IP Source Routing	Reconnaissance, DoS
Control Device Access	TACACS+, Radius, Password Encryption	Unauthorized access
Secure Ports and Interfaces	Disable unused interfaces, VLAN Pruning	Reconnaissance, DoS
Secure Routing Infrastructure	MD5 Authentication, Route Filters	DoS, Collateral damage
Secure Switching Infrastructure	Port Security, Storm Control	DoS, Collateral damage
Control Resource Exhaustion	CoPP, Hardware-based Rate Limiters	DoS, Collateral damage
Policy Enforcement	uRPF, iACLs	IP spoofing, DoS
DSLAM	MAC Forced Forwarding, Virtual MACs, DHCP Option 82, IGMP Whitelist	Reconnaissance, MAC spoofing, Theft-of-Service



# Product Portfolio



## Slide 39

---

**JGD1**

I agree with Andrew's comments on this section. Make system testing a separate section, and split QoS and High Availability into separate sections. Add a section on security would be a nice addition; I have some slides used to talk with BT that I will forward along as well.

Jason Dachtler, 6/6/2007





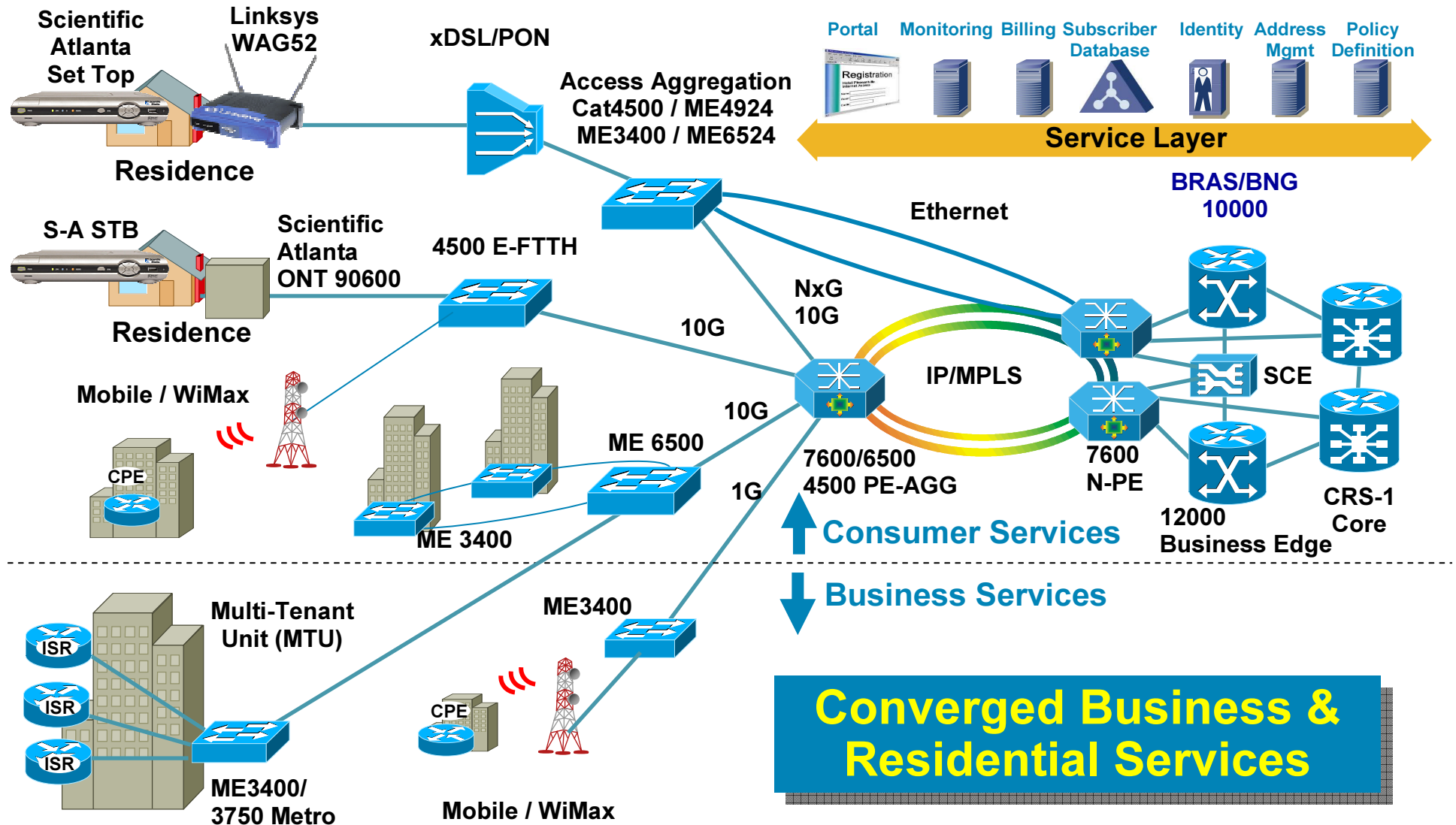

































# IP NGN Carrier Ethernet Design

## End-to-End Consumer and Business Services



# Cisco IP NGN Innovation Breadth and Depth

## Delivering Unique Value to Experience Providers

<b>Application</b>	<p>Changing Business Operations Telepresence</p> 	<p>Unified Personal Communications</p> 	<p>Mobile Unified Communication</p> 	<p>IP Phone Leader</p> 	<p>Video Portal</p> 	<p>Consumer Experience Media Center</p> 			
	<p>VoIP Softswitch MSO's Choice</p> 	<p>Video Program Receiver and Subtitling</p> 	<p>Best Video Encoder</p> 	<p>Most Advanced SetTop</p> 	<p>Picture in Picture</p> 	<p>Secure, Fast Content Delivery</p> 			
<b>Service Layer</b>	<p>PGW Class 4 Switch, WW Lead</p> 	<p>IP-IP Gateway</p> 	<p>Setting the Pace for Video Quality</p> 	<p>SGSN</p> 	<p>GGSN</p> 	<p>Policy Management</p> 	<p>SCE: Application Management</p> 	<p>SP's Choice Session Border Control</p> 	<p>#1 share Media Gateways</p> 
	<p>Broadband Aggregation Leader</p> 	<p>Leader in Managed Security</p> 	<p>ME3400 Ethernet Access Switches</p> 	<p>12k Multi-Service Edge</p> 	<p>ISG: Subscriber Management</p> 	<p>First Ethernet Service Edge for Quad-Play</p> 	<p>#1 share CMTS</p> 	<p>CRS-1 #1 92TB 40G Router</p> 	
<b>Network Layer</b>	<p>51% Market Share ROADM</p> 	<p>Cable Modem</p> 	<p>Industry First Tunable 40G</p> 	<p>Industry First Tunable 10GE</p> 	<p>Leader Active FTTx Aggregation</p> 	<p>ME4900 Ethernet Aggregation</p> 	<p>1st Networked DVD Player</p> 	<p>WiFi Access Point</p> 	<p>Digital Media Player</p> 

# Cisco Carrier Ethernet Portfolio

## Award Winning – Excellence in Innovation



### IP/MPLS and Ethernet



CRS-1



12000 / XR 12000

Cisco 7600



Cisco 10000

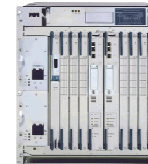

Cisco 72xx/73xx



ME 6524



Catalyst 3750 Metro



ME 4924



ME 3400



Integrated Services Router

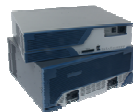

Catalyst 4500



Catalyst 6500



### Ethernet/SONET/SDH Ethernet/ DWDM

ONS 15454



ONS 15600



ONS 153xx



### Cisco Carrier Ethernet Solutions Deliver :

- Architectural Flexibility - Network Convergence
- Service Richness - Complete Solutions
- MEF9 and MEF 14 Certified
- Portfolio Breadth – End to End Manageability (Ethernet OAM)



# Metro Ethernet - Services Opportunities

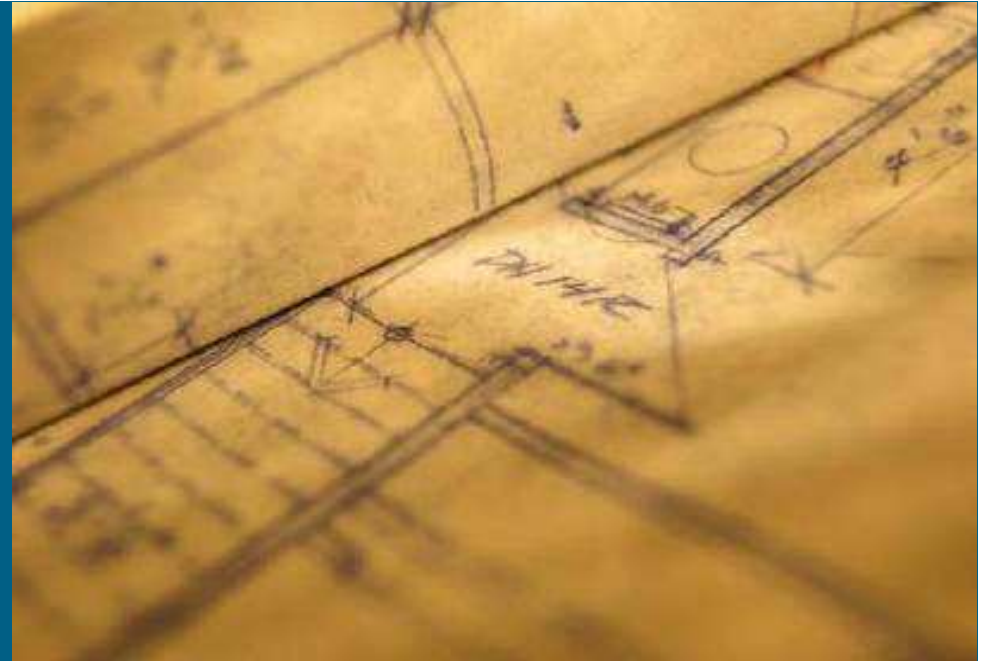

# Carrier Ethernet Networks

## Services

Market	Services	Access	SLA Type	SLA Example
Residential	Internet Access	Ethernet, DSL	Transport	Dynamic access bandwidth, session/idle timeout, advertisements, post paid/prepaid (time and volume)
	VoIP Telephony	Ethernet, DSL	Application	The number of VoIP appliances, SIP URLs/PST Phone numbers, active calls, VoIP call quality
	VoD	Ethernet, DSL	Application	The number of STBs, stream quality, content flavours, charging models
	TV	Ethernet, DSL	Application	The number of STBs, type of TV packages, SD vs HD content and delivery quality
Business	L3 VPN	Ethernet, DSL	Transport	Access bandwidth, differentiated services support, L3 VPN topology, managed services
	E-Line	Ethernet, DSL	Transport	Access bandwidth, differentiated services support, transparency
	E-LAN	Ethernet, DSL	Transport	Access bandwidth, differentiated services support, multipoint transport, transparency
Wholesale	L3 (P2P, MP)	DSL	Transport	Aggregated bandwidth on ISP level, differentiated services support, with subscriber management at ISP
	L2 (P2P, MP)	DSL	Transport	Aggregated bandwidth on ISP level, differentiated services support, transparent Ethernet transport P2P and MP (multicast optimized)

# Metro Ethernet Services

## Some Market Insertion Options

- Position Ethernet TLS / VPLS where higher bandwidth and flexible connectivity is required to minimize cannibalization  
MAN/Campus
- Ethernet private line services for demanding environment  
Data centers
- Extend current FR/ATM and IP VPN services with Ethernet access where higher bandwidth is required  
Large office site, data centers, broadband access alternative
- Selling best-effort Ethernet services  
Target segment require large cost-effective MAN bandwidth (education, government) High speed Internet access
- Evolve services to offer CoS and bandwidth guarantees  
Support voice/data/video convergence & grow revenue



# Metro Ethernet Services Target Markets



- Data centers
- Campus
- LAN interconnect
- High-speed internet
- Storage/backup

## Key Industries

- Finance/education/healthcare/federal/manufacturing

- SMBs in MXU
- Business parks
- Multitenant access
- High-speed Internet
- Managed service bundles

- High-speed broadband
- Residence in MDU
- Deliver “triple play” of voice, video and data services

- IOF connectivity
- DSLAM transport
- Metro access/  
tail circuit
- xLEC
- SSP
- ISP
- ASP
- WSP



# References



# Cisco Carrier Ethernet Solution



## Ethernet Backhaul Overview

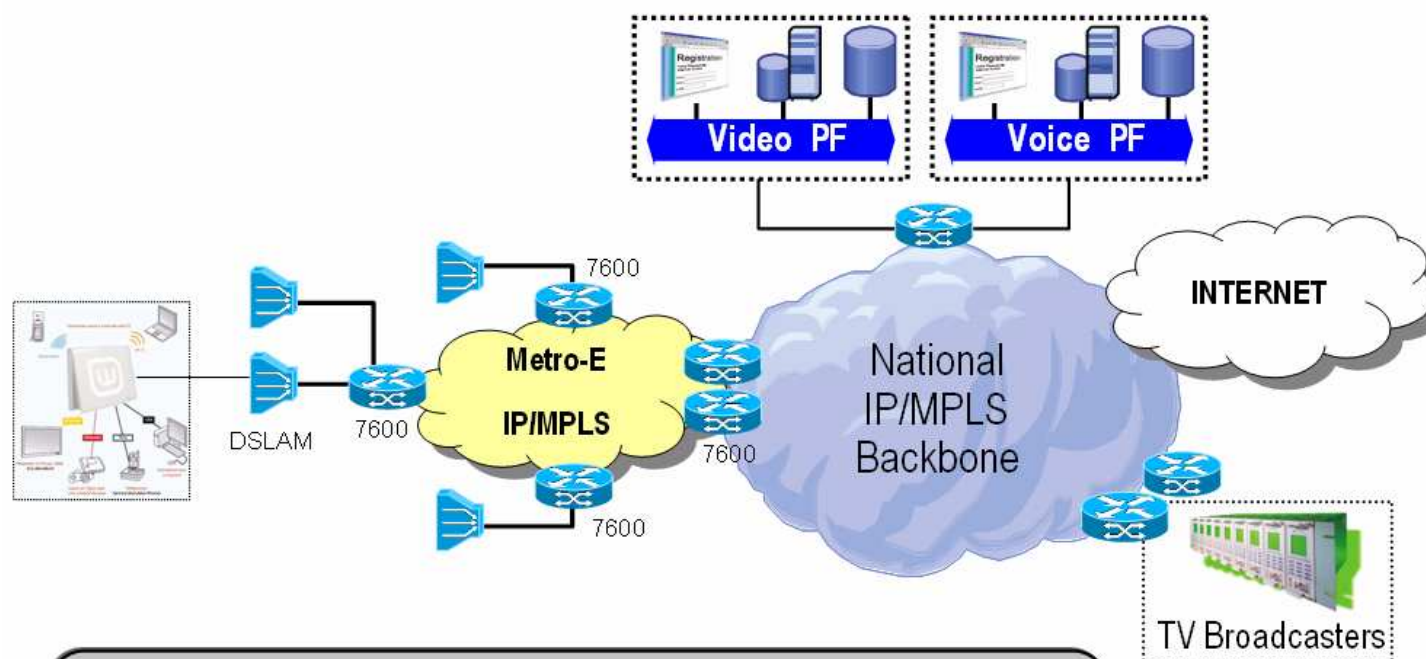

- IP Unicast for VOD Traffic
- IP Multicast for TV Broadcast traffic
- L2VPN Pseudowires for PPPoE Internet Traffic from Metro-E Node to BRAS
- L3VPN for future SIP-based Voice services.
- ... more to come

# Cisco Carrier Ethernet Solution

- Digital quality TV over DSL
- QoS enabled, Intelligent Video distribution

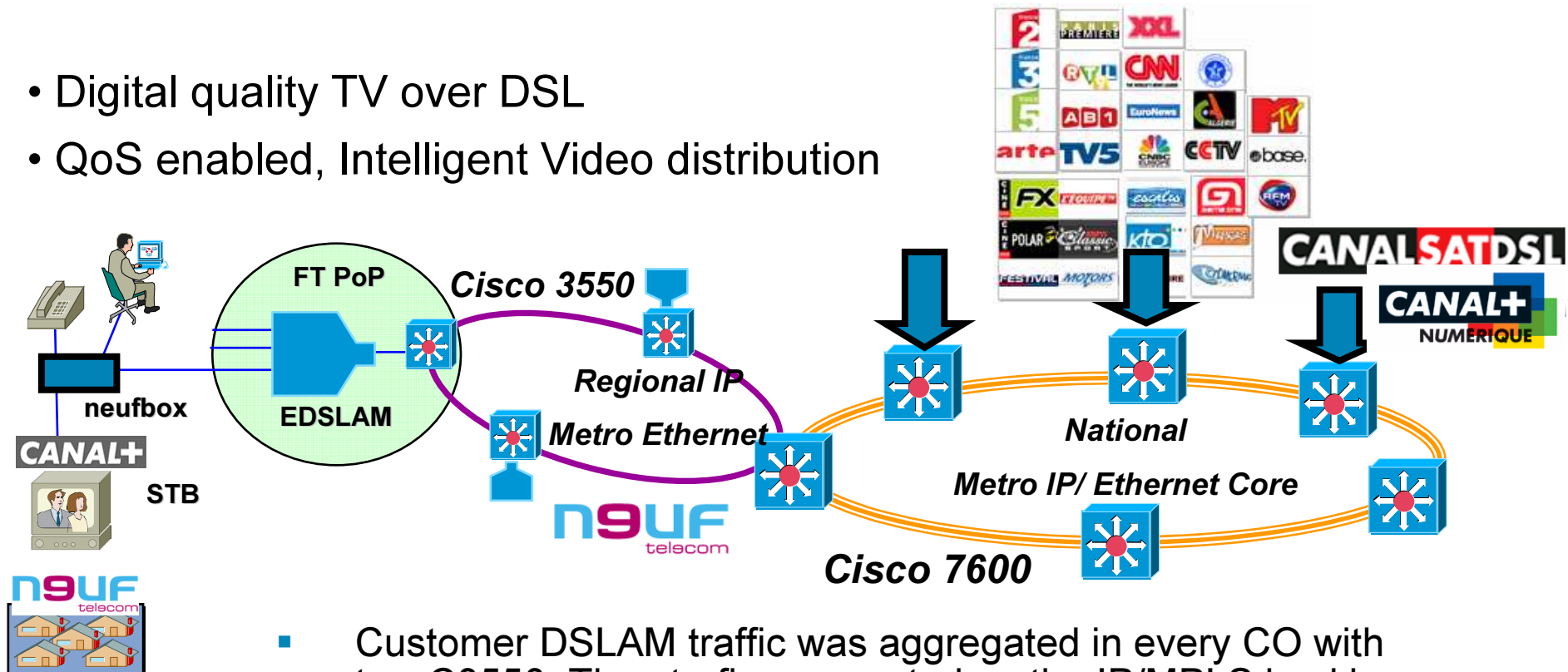

- Customer DSLAM traffic was aggregated in every CO with two C3550. Then traffic was routed on the IP/MPLS backbone based on C7600 to finally reach the internet network.
- 12 PoP with 2 Cisco 7600 each deployed nationwide.
- Basic configuration is Cisco7606 (DC), single SUP720-3BXL (MPLS P), WS-X6724-SFP line cards.

# Cisco Carrier Ethernet Solution

Cisco 7600 Series Routers x 50 (MPLS to the edge)  
 Cisco ME 6524 Ethernet Switch x 386 (L2/L3 VPN)

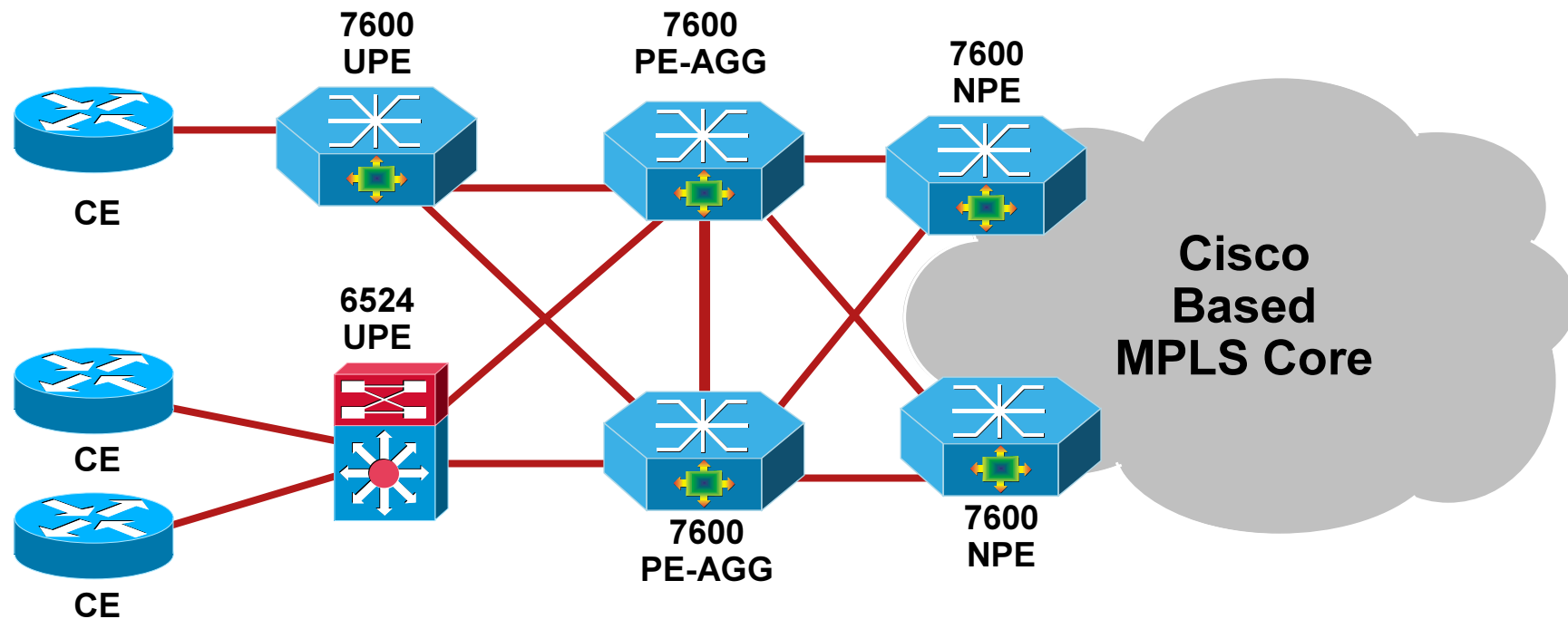

# Cisco Carrier Ethernet - EFTTH Solution

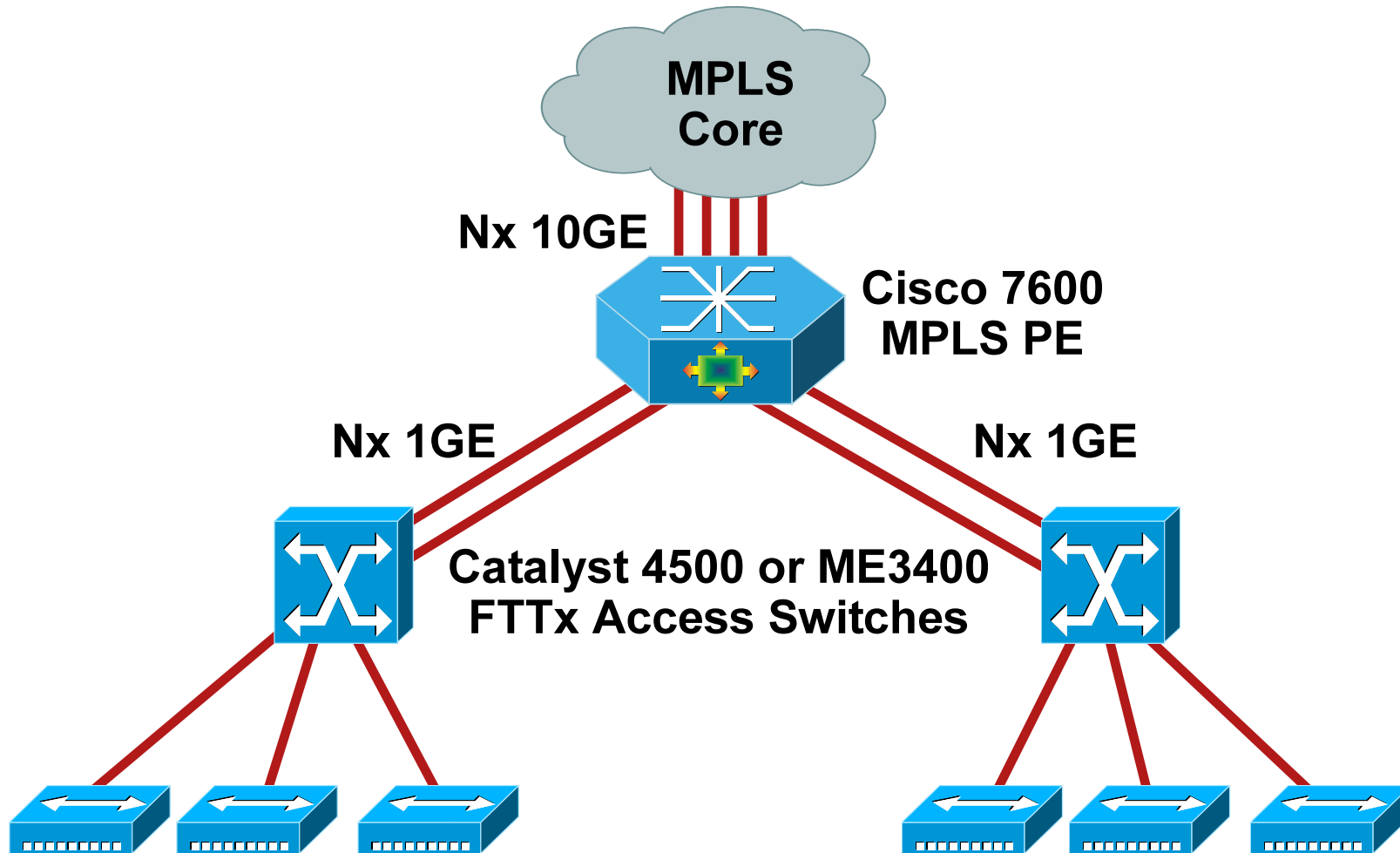

# Cisco End-to-End Ethernet FTTH Enhanced Customer Experience New Revenue and Customer Loyalty

## E-FTTH Advantages

Scalable from 1 Mbps to 1Gbps

- Symmetrical bandwidth
- Flexible Business Model
- Migration to higher bandwidth w/o truck rolls
- Granular QoS profiles per customer
- Network resiliency

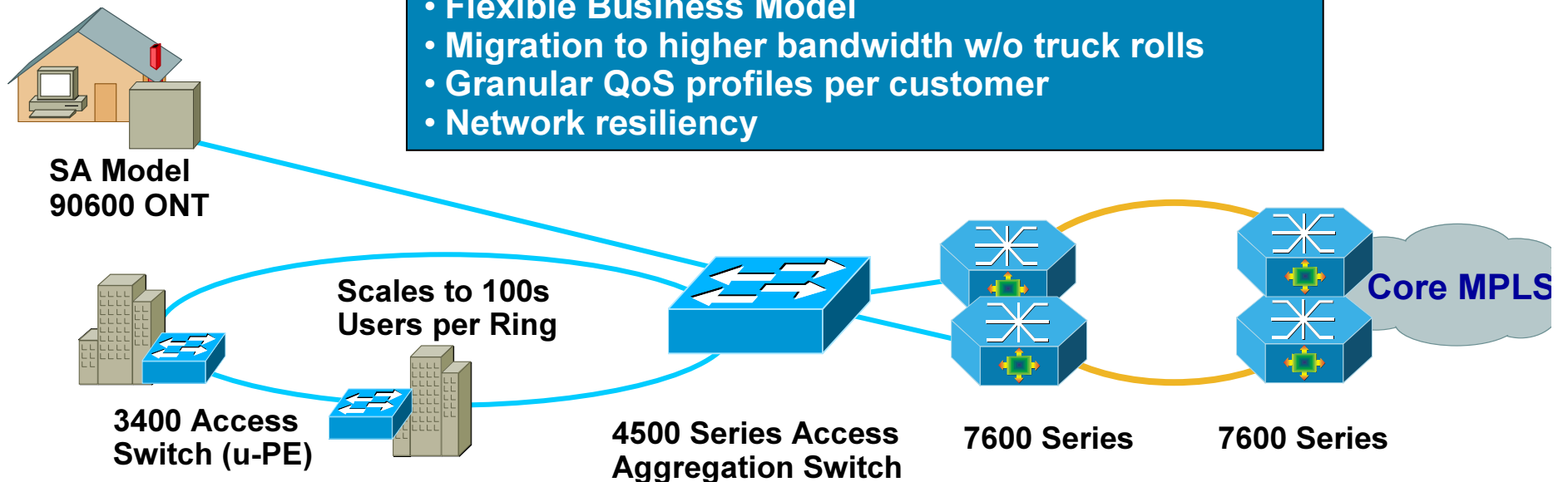

**Over 100 FTTH Networks Deployed Globally  
2M+ Subscribers on Cisco E-FTTH Aggregation Networks**



