

Design Principles for Metro Optical Networks

- **WDM Technologies**
- **Dense Wave Division Multiplexing (DWDM)**
- **Cisco ONS 15454 MSTP**

WDM Technologies

WDM Terminology— Transponder

Cisco.com

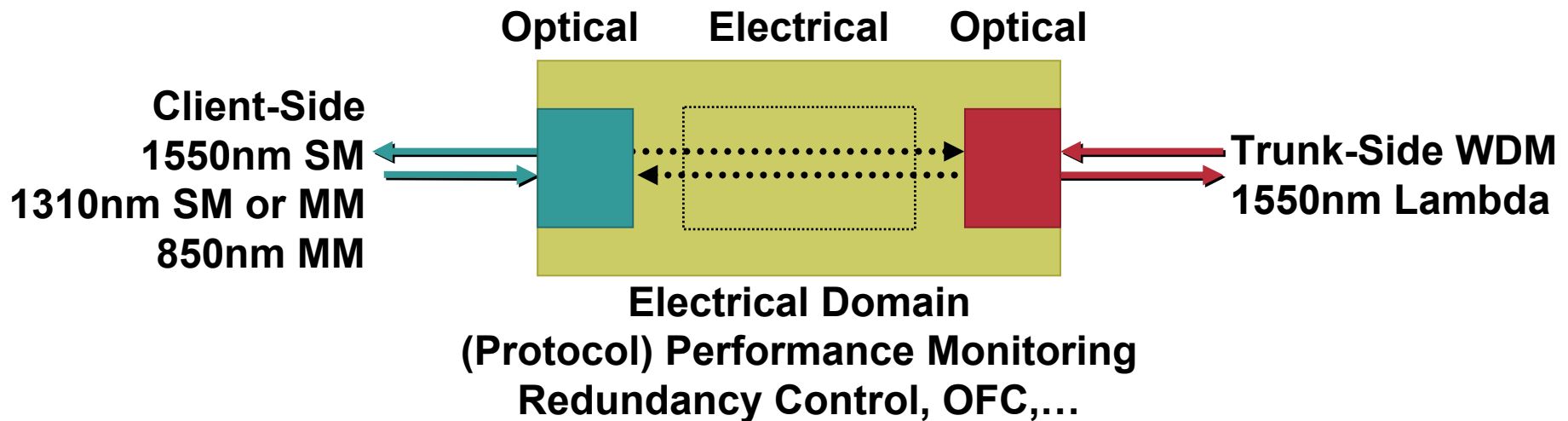

- **2R—Regenerate and Reshape**
- **3R—Regenerate, Reshape and Retime**

WDM Terminology— Optical Filter (OADM)

Cisco.com

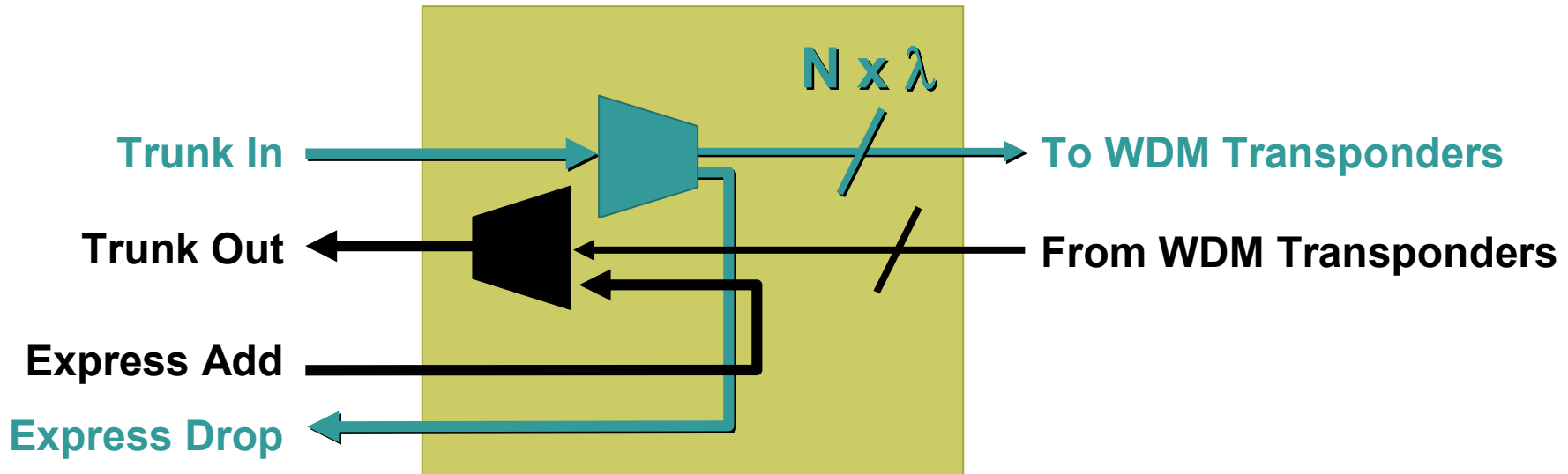

- **Filters with 1, 4, 8 or 16 channel add/drop**
- **Trunk connects from previous filter or site**
- **Express connects to next filter or site**

WDM Terminology

- ***Add_Loss***

dB loss when a channel is added to a particular MUX or OADM

- ***Drop_Loss***

dB loss when a channel is dropped from a particular DMUX or OADM

- ***Pass_Loss***

dB loss associated when a channel is passing through an OADM

WDM Terminology (Cont.)

- ***Total_Pass_Loss***

Sum of the dB pass loss as a channel is passed between the add site and the drop site

- ***Total_Span_Loss***

Sum of the dB loss in each span of the fiber between the add site and the drop site including patch fields and leads

- ***Dispersion_Penalty***

Subtract 2dB for $\geq 60\text{km}$ and 3dB for $\geq 100\text{km}$

WDM Terminology— dB Losses in a System

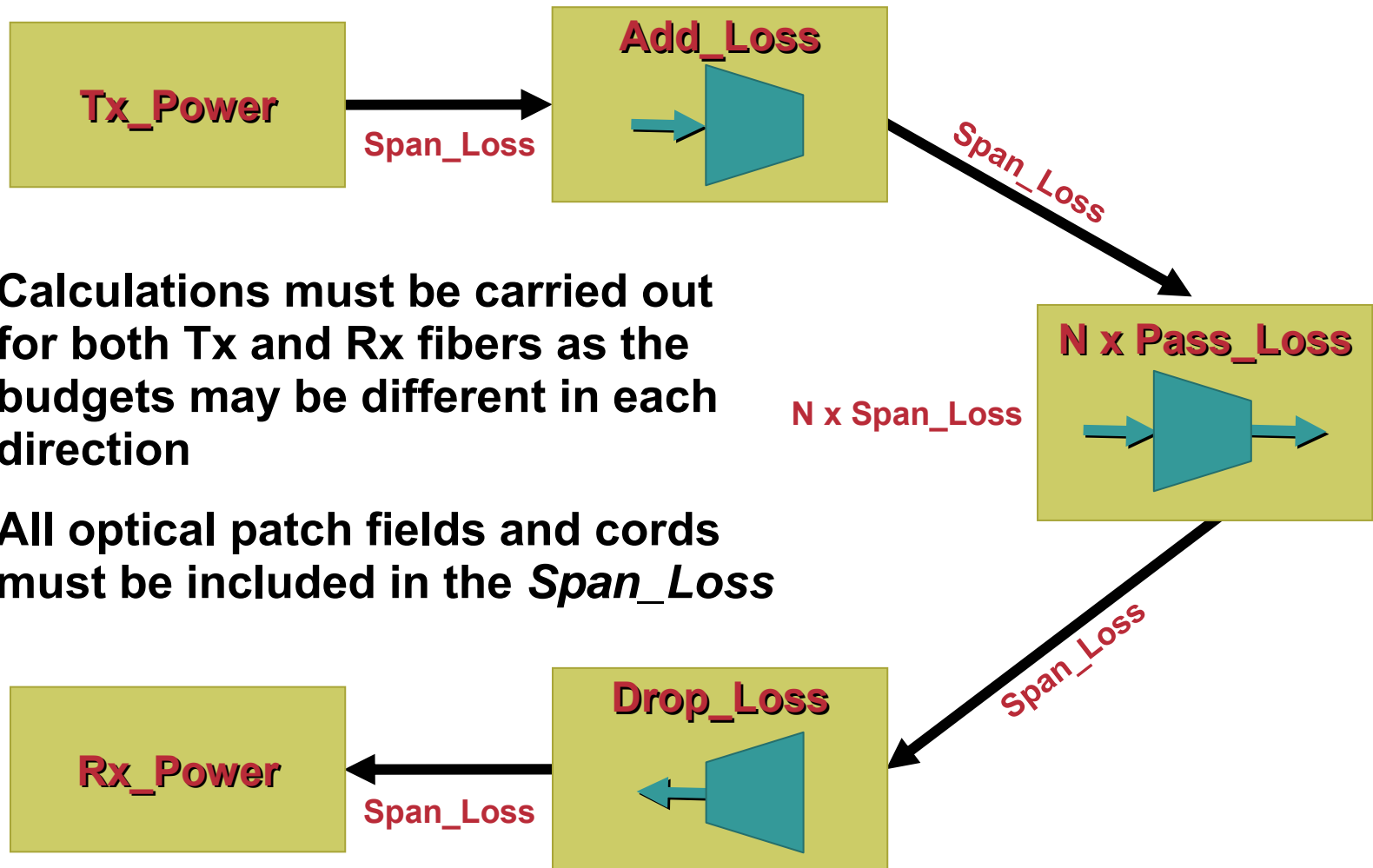

- Calculations must be carried out for both Tx and Rx fibers as the budgets may be different in each direction
- All optical patch fields and cords must be included in the *Span_Loss*

WDM Optical Budget Calculation

- Ensures enough optical budget for the link
- Calculate the optical budget for each span using the worst case dB losses
- *Minimum_Tx_Power* –
Minimum_Rx_Power –
Maximum_Add_Loss –
Maximum_Drop_Loss –
Total_Maximum_Pass_Loss –
Total_Span_Loss –
Dispersion_Penalty ≥ 0

WDM Receiver Sensitivity Calculation

- Ensures there is no receiver saturation
- Calculate the Rx sensitivity for each span using the best case dB losses
- *Maximum_Tx_Power* –
Typical_Add_Loss –
Typical_Drop_Loss –
Total_Typical_Pass_Loss –
Total_Span_Loss –
Dispersion_Penalty \leq *Maximum_Rx_power*

WDM Systems Implementation Rules

- Use **SM Fiber ONLY**, make sure all your patch cords are **YELLOW** and **NOT Orange**
- Do the optical budget calculations for every trunk transceiver in **BOTH** Tx and Rx directions (they will differ)
- You will **ABSOLUTELY POSITIVELY** need an **Optical Power Meter** to implement these networks, do **NOT** do it without or you will spend days driving between sites and get **VERY FRUSTRATED!**
- **Clean** every fiber connection and every patch cord before you measure or provision the circuit

DWDM

Dense Wave Division Multiplexing (DWDM)

- **Combination of a series of up to 32 tuned wavelength transponders, optical filters, attenuators and amplifiers.**
- **100Ghz spaced grid 1530nm–1560nm**
- **Can be optically amplified**
- **Ideal for large scale metropolitan GigE, 10GbE and storage deployments on dark fiber**

DWDM—Protection

- **Protection mechanisms**
 - Splitter-based protection**
 - Lambda-based protection**
 - Client-based protection**
- **Protection signalling**
 - Optical/analogue parameters—LOS/LOL**
 - Digital performance monitoring parameters—application-specific**
 - Client-side/trunk-side**
- **Path switching**
 - Uni-directional**
 - Bi-directional**

DWDM—Splitter Protection

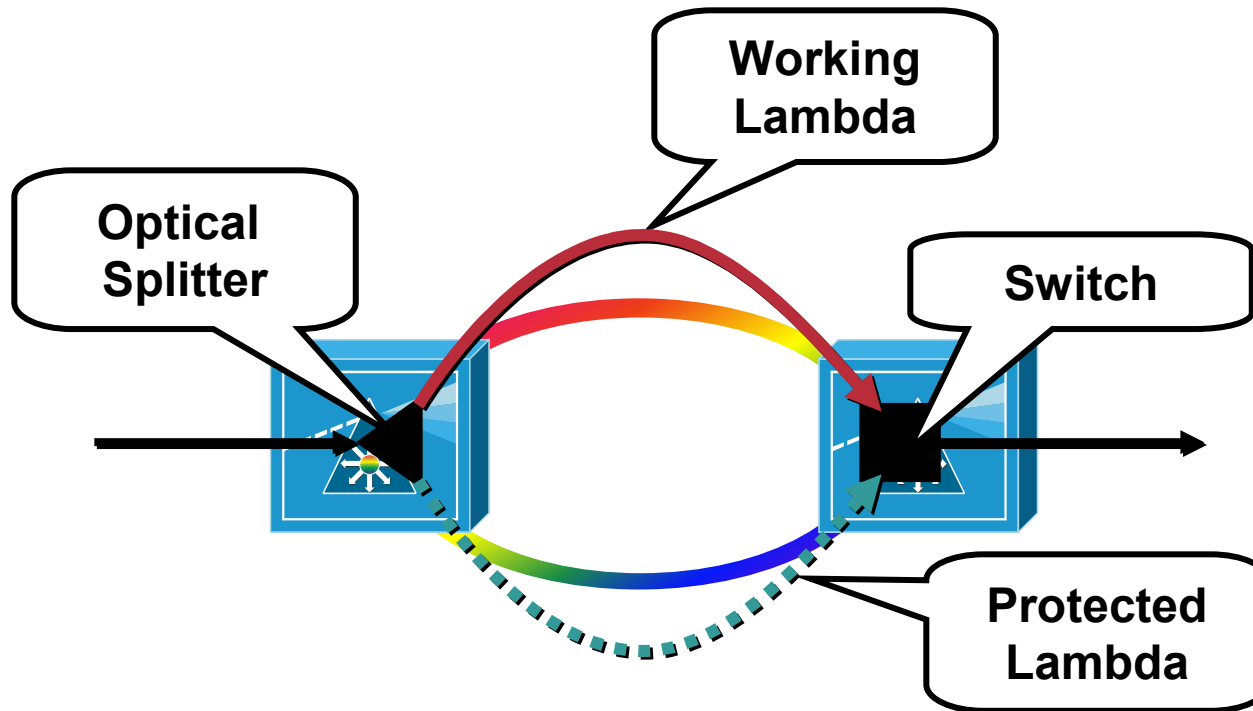

- **Single transponder with optical splitter**
- **Receiver selects active signal path**

DWDM—Lambda Protection

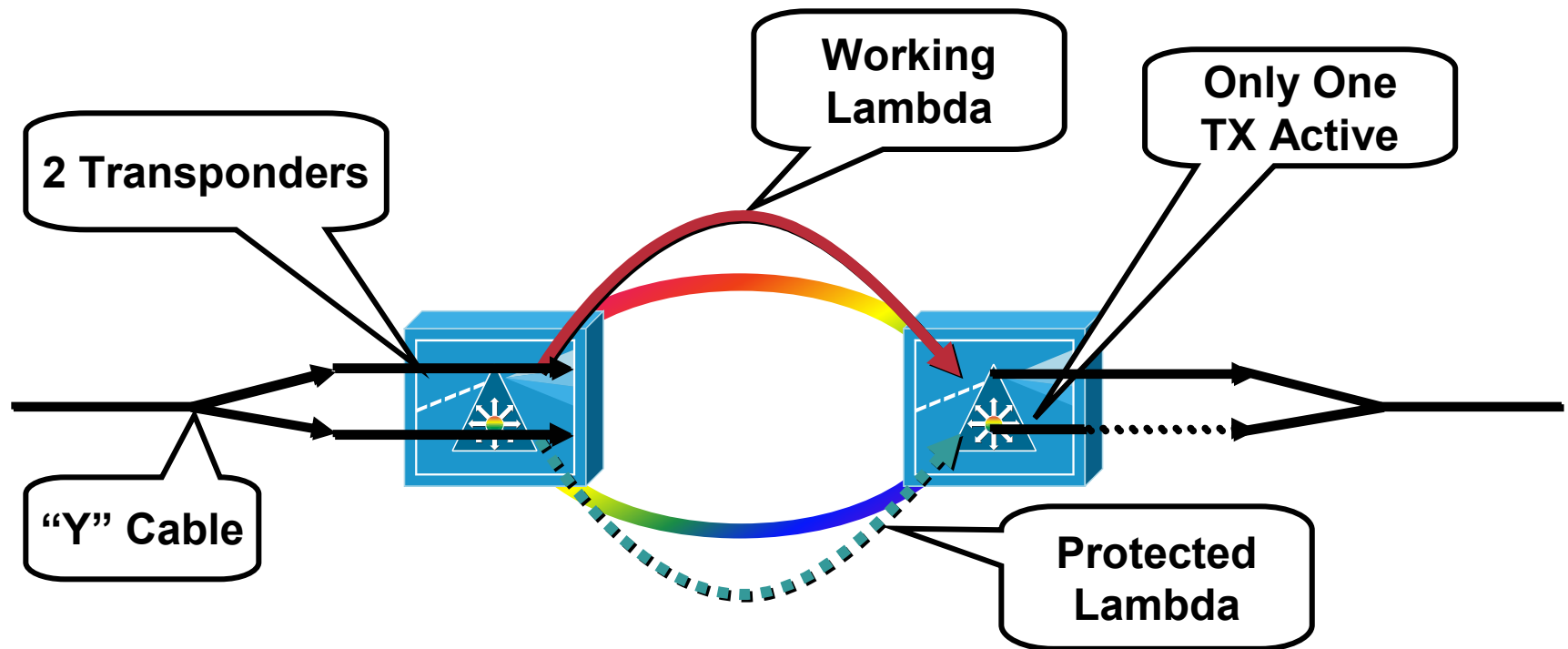

- **Dual transponders with optical splitter on CPE connection**
- **Receivers negotiate for active signal path**

DWDM—Client Protection

Cisco.com

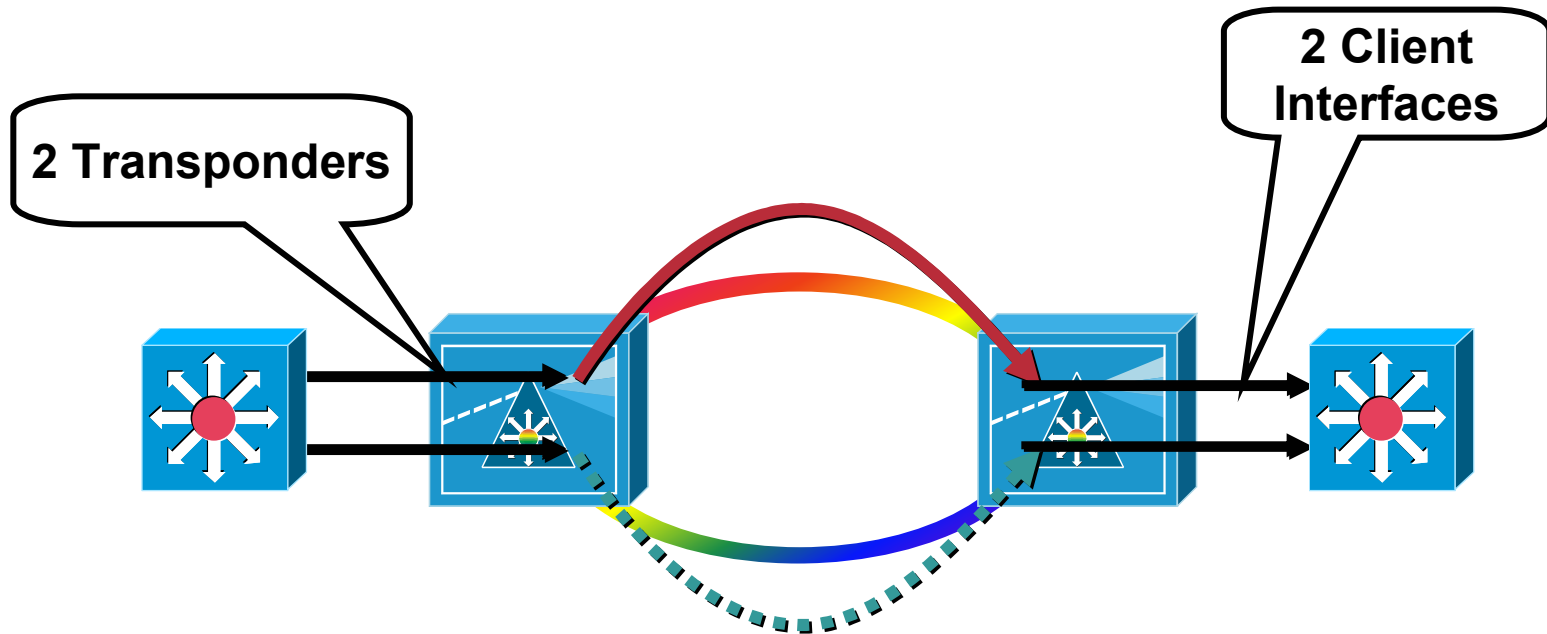

- **Dual transponders and dual CPE interfaces**
- **Protection via L2 or L3 on CPE equipment**

DWDM—Uni-Directional Protection Switch

Cisco.com

- OK for GigE and OC-3/OC-12
- Cannot be used for high-speed and storage protocols due to excess jitter
- The receiver alone makes the decision

Normal Operation

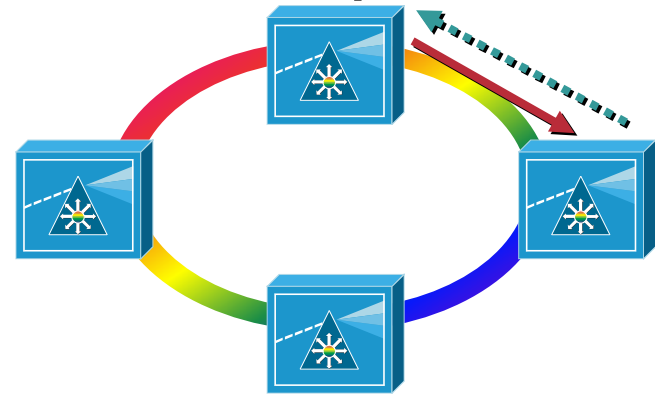

Both Cores Cut

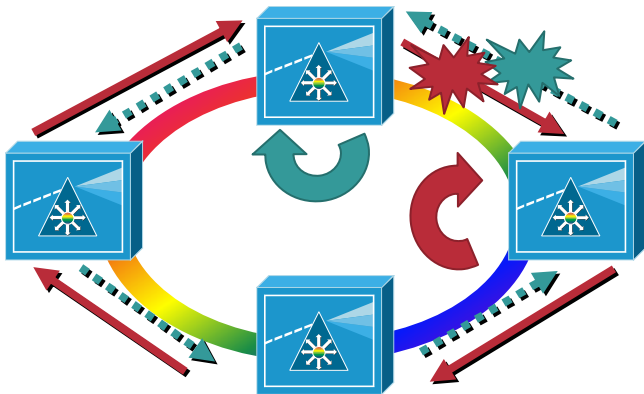

- Both sides of ring will wrap
- Distance on Tx and Rx path same

Single Core Cut

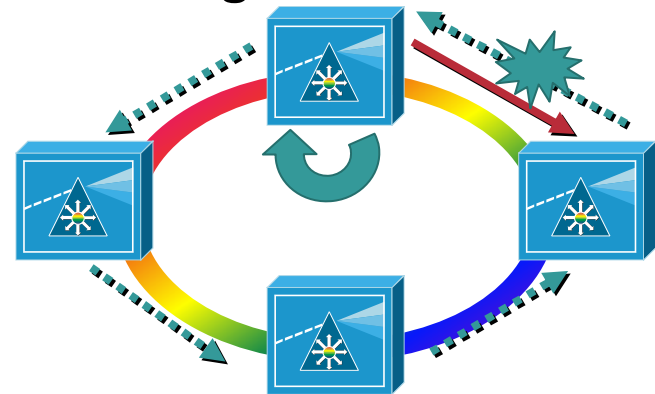

- Single side of ring will wrap
- Distance on Tx and Rx path different

DWDM—Bi-Directional Protection Switch

Cisco.com

- OK for all protocols except sysplex timer
- Notification to remote receiver to perform “wrap” via Optical Supervisory Channel

Normal Operation

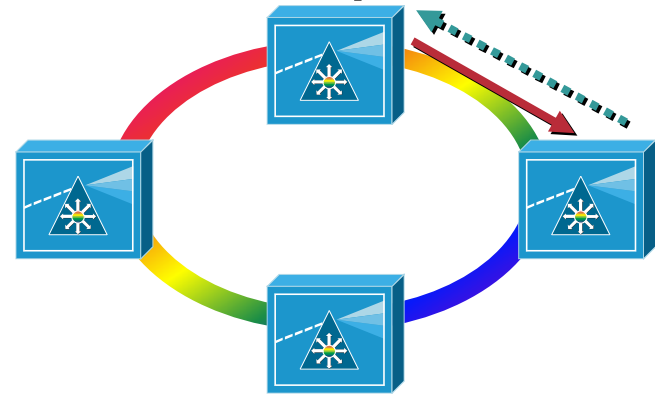

Both Cores Cut

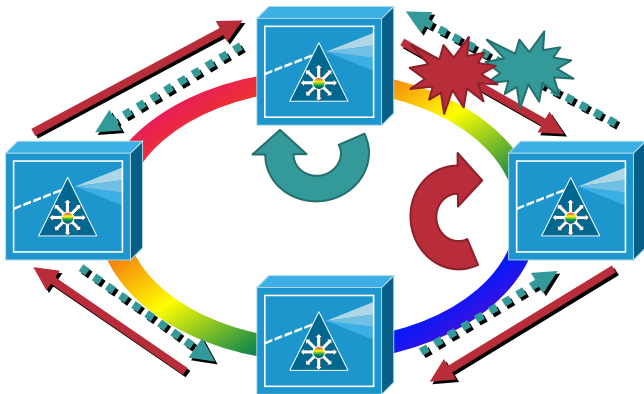

Single Core Cut

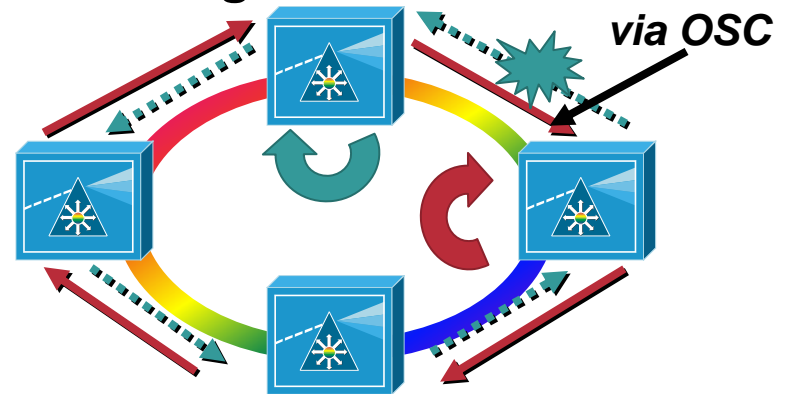

- Both sides of ring will wrap
- Distance on Tx and Rx path same

Deploying DWDM—Test Equipment

- **Optical Power Meter (OPM)**

Absolutely vital for all optical installations to verify there is “light” from the transmitter and the Rx sensitivity is within tolerance

- **Spectrum Analyzer (OSA)**

Required to ensure in WDM systems that the optical channels are balanced before multiple optical signals are amplified

- **Optical Time-Domain Reflectometer (OTDR)**

Required to test single mode fiber for splices, cuts, optical loss and to ensure optical budgets are met by the fiber service provider

DWDM Common Deployment Issues

- **Mismatch—Client interface and application**
Application out of spec—Under or over driven
- **Connectors not fixed or dirty**
Dirty connectors “transfer” dirt
- **Inappropriate light source used for testing**
Modulated signal must be used
- **Budgets out of specification**
- **Inappropriate attenuation techniques**
Core shifted splicing with MM cables
Air gap attenuators

DWDM Topologies

Point to Point—Logical Topology

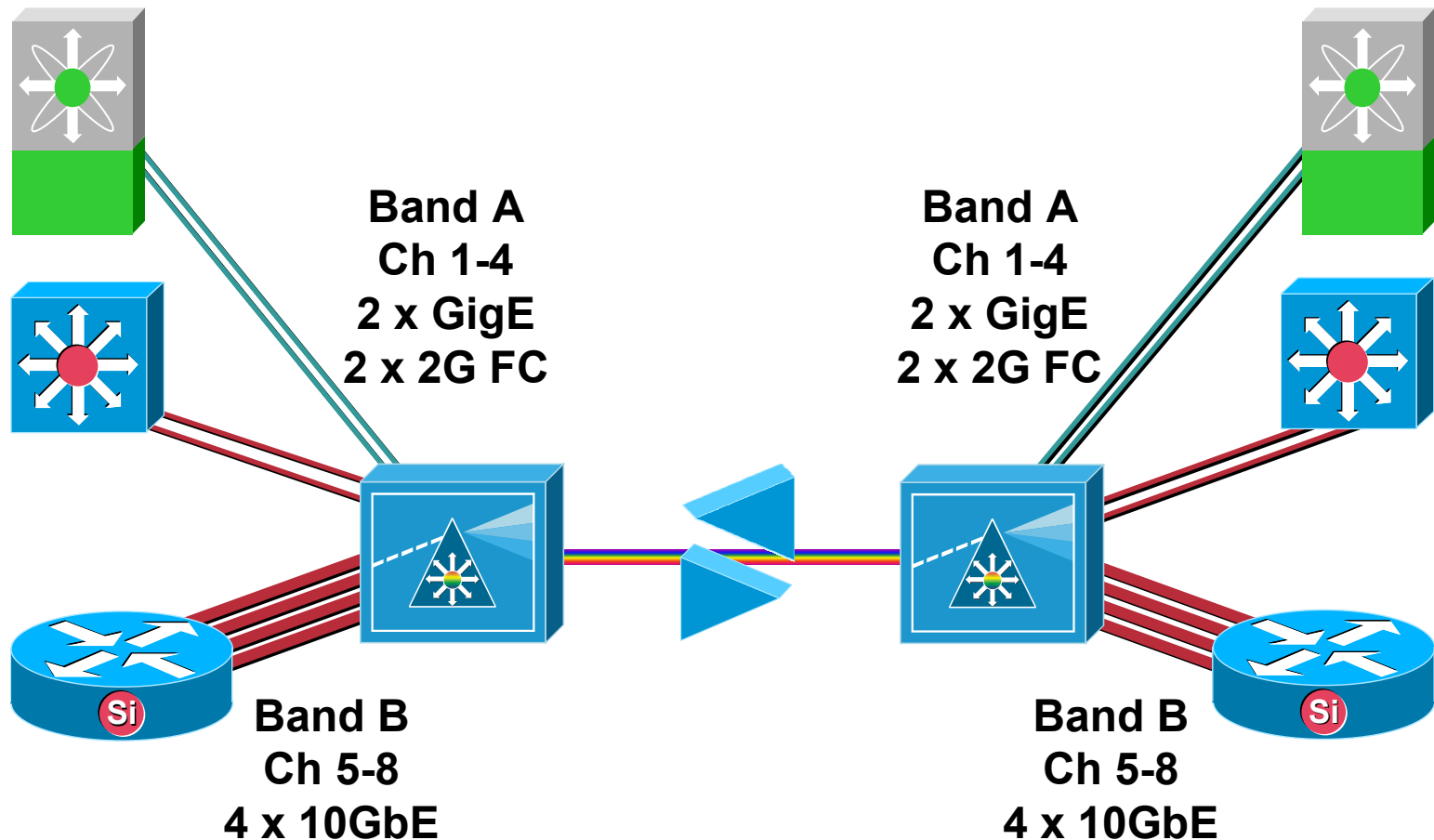

DWDM Topologies

Point to Point—Physical Topology

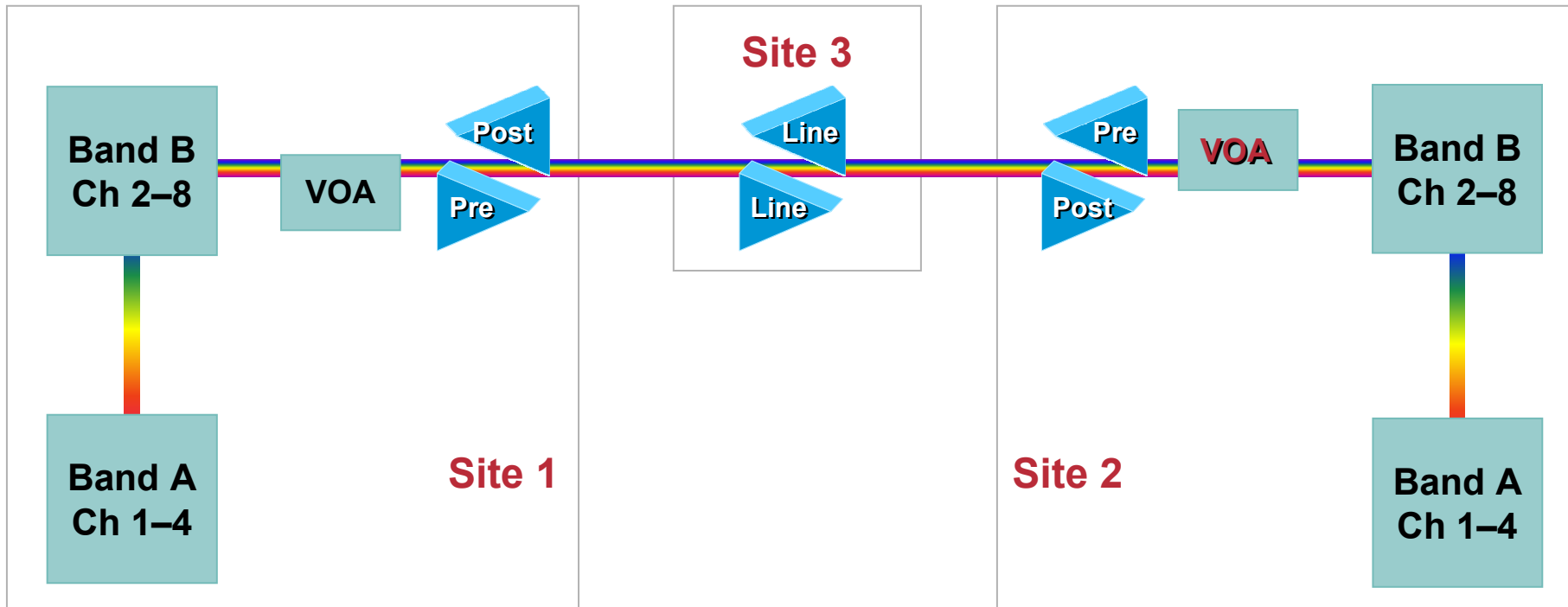

- **VOA's required to attenuate band B channels to an equal level of band A channels**
- **If 10GbE or OC192 is deployed then the governing factor is dispersion limits on the equipment and fiber (~80km for 10GbE)**

DWDM Topologies

Protected Hubbed Ring—Logical Topology

Cisco.com

Band AB—Site 1 to Site 2
Band CD—Site 1 to Site 3

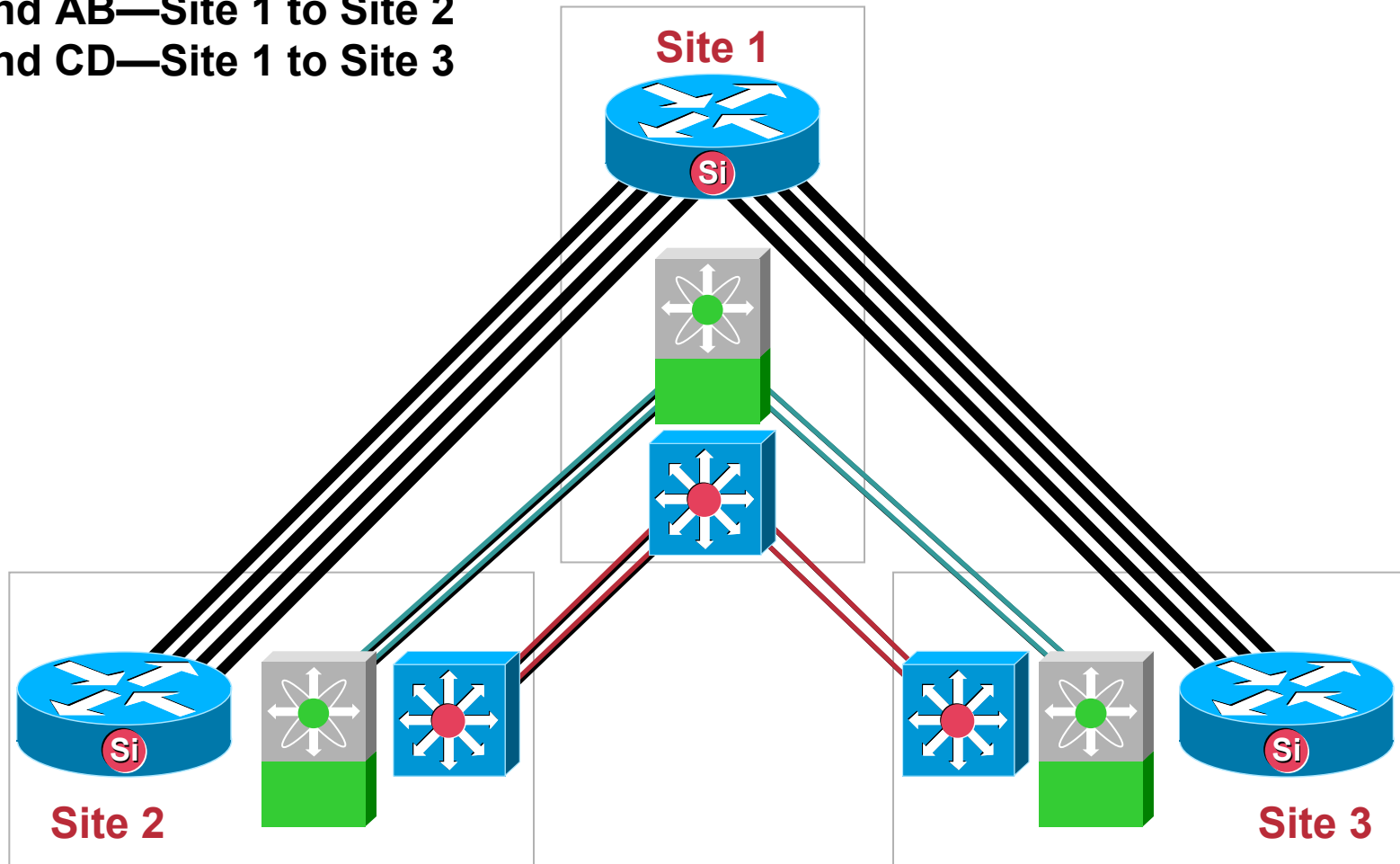

DWDM Topologies

Protected Hubbed Ring—Physical Topology

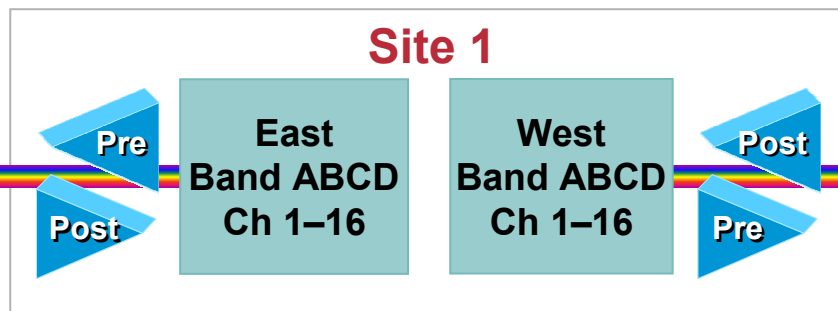

- No Fiber between MUX's in hub site 1
- No need for VOA's at hub site 1

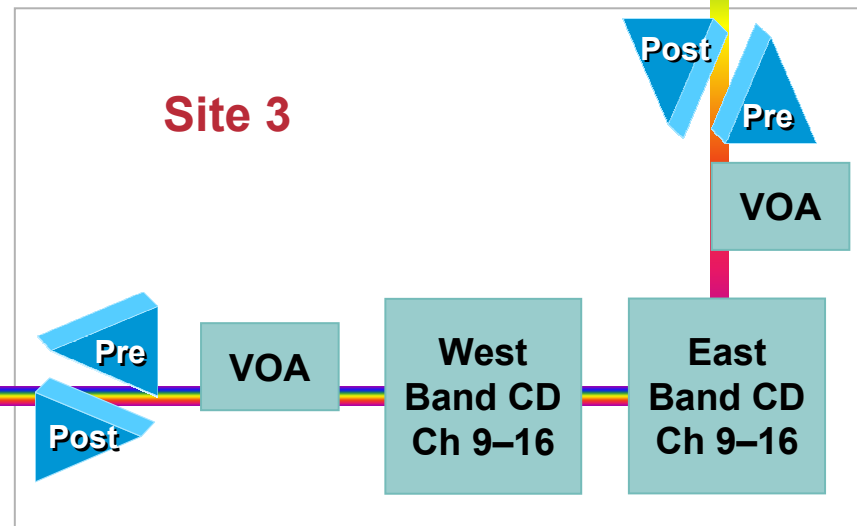
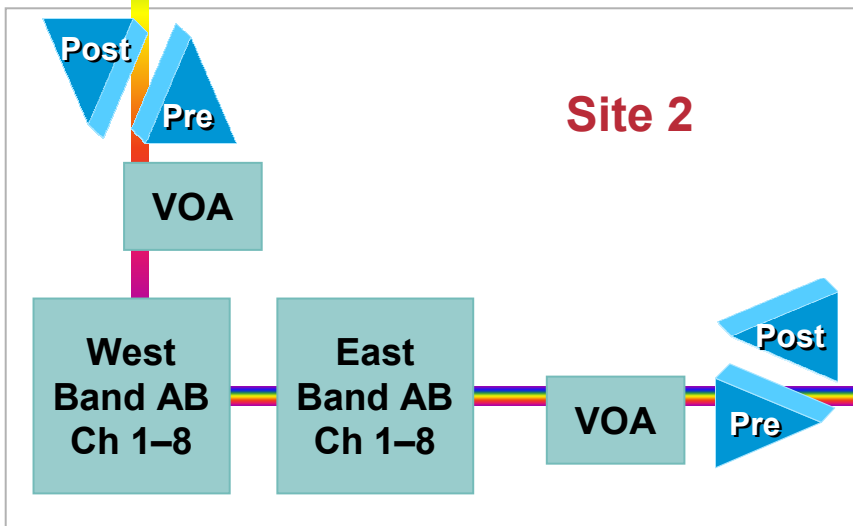

DWDM Topologies

Protected Meshed Ring—Logical Topology

Cisco.com

Band A—Site 1 to Site 2
Band B—Site 1 to Site 3

Band C—Site 1 to Site 4
Band D—Site 2 to Site 3

Band E—Site 2 to Site 4
Band F—Site 3 to Site 4

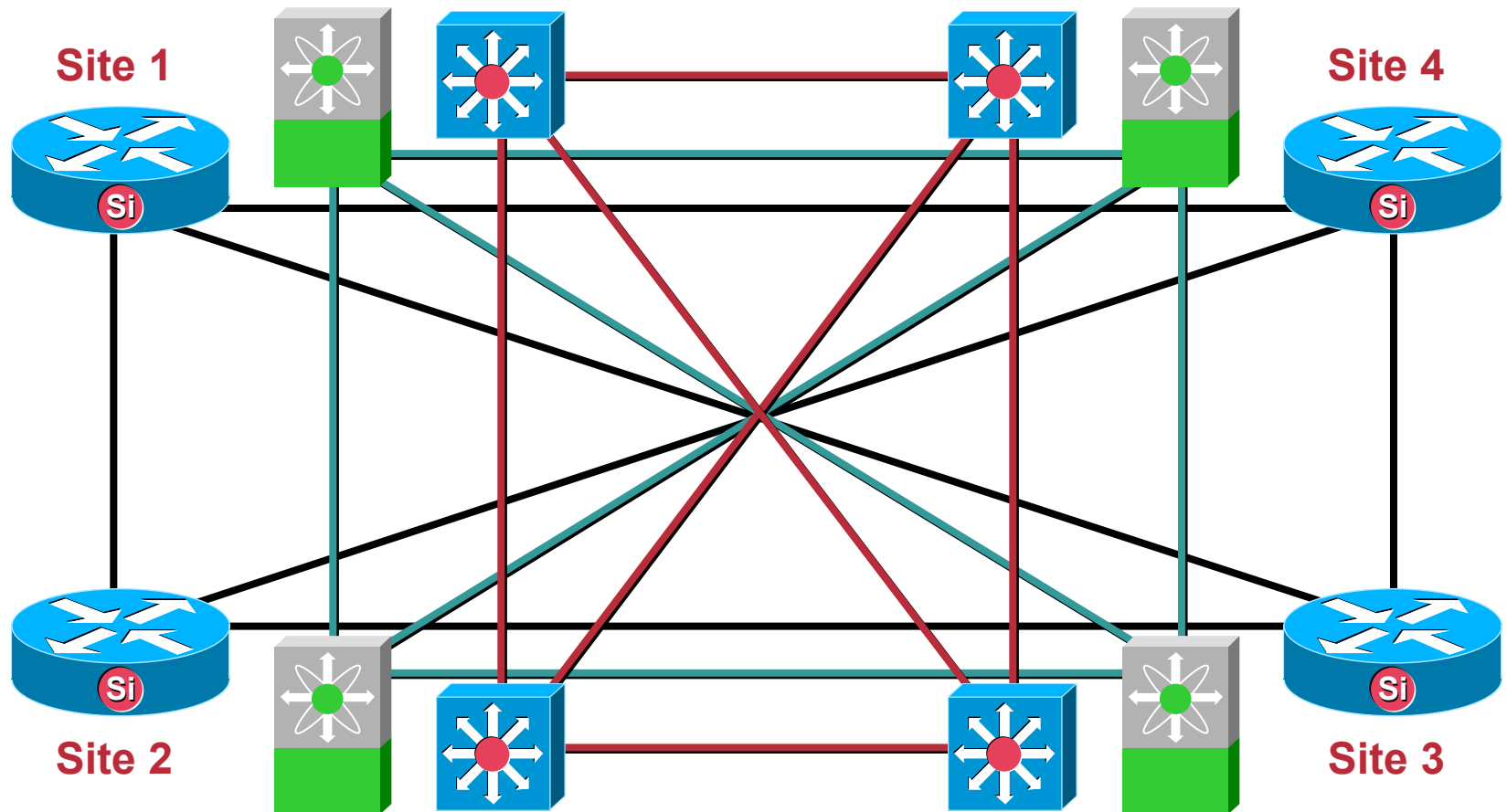

DWDM Topologies

Protected Meshed Ring

Cisco.com

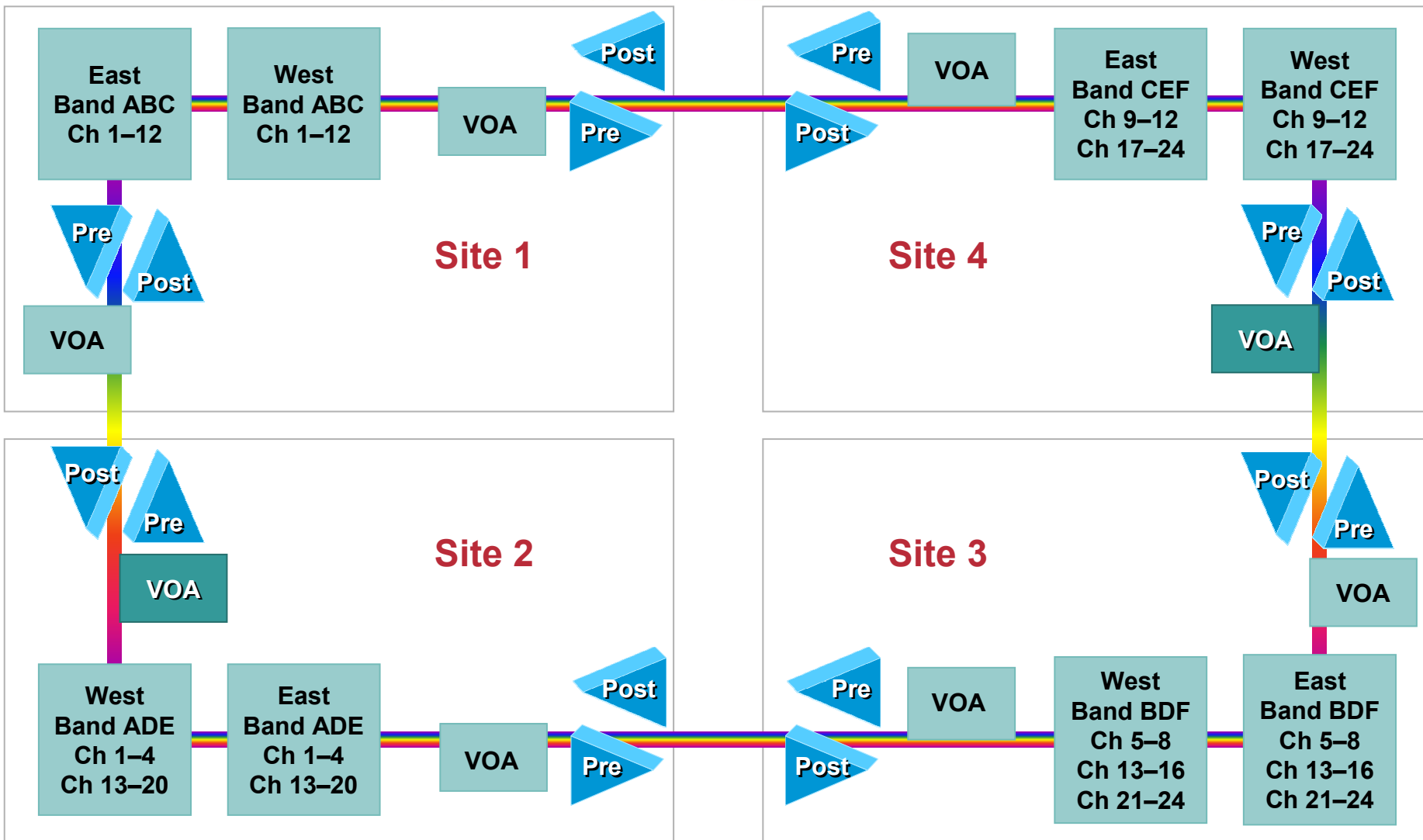

Cisco.com

Cisco ONS 15454 MSTP



What is a Multi-Service Provisioning Platform?

- **Pure SONET** - time division multiplexing of voice traffic
- **'Next-generation' SONET** - combines both transport of analogue voice as well as data over SONET
- **Multi-Service Provisioning Platforms** - also deliver TDM, Layer 2 and Layer 3 Ethernet functionality as well

What is a Multi-Service Transport Platform?

Multi-Service Transport Platform is the next step Cisco is taking to:

- Integrate MSPP functionalities with DWDM Transport capabilities
- Extend the “Fast, Easy & Simple” architecture to the DWDM domain
- Introduce the “Intelligent Optical Transmission” concept
- Provide a new Optical platform that can scale from Metro to Metro-Core and to Regional Networks

Cisco Metro Regional DWDM Approach: Eliminating Complexity

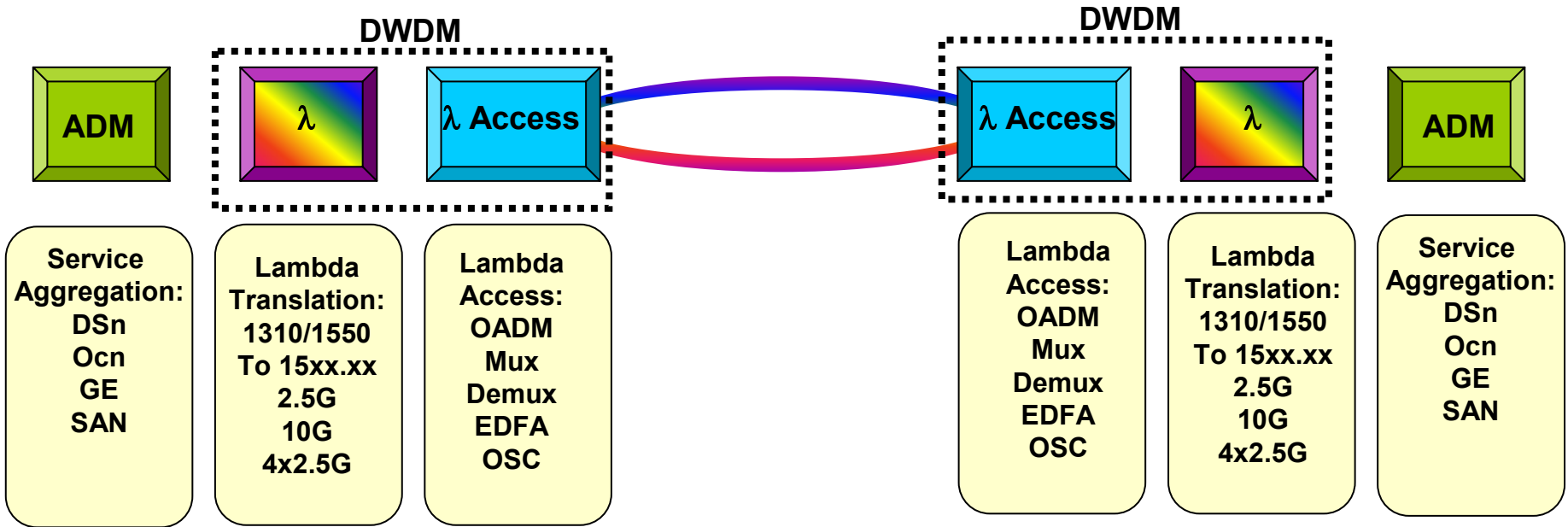

Cisco Metro Regional DWDM Approach: Eliminating Complexity

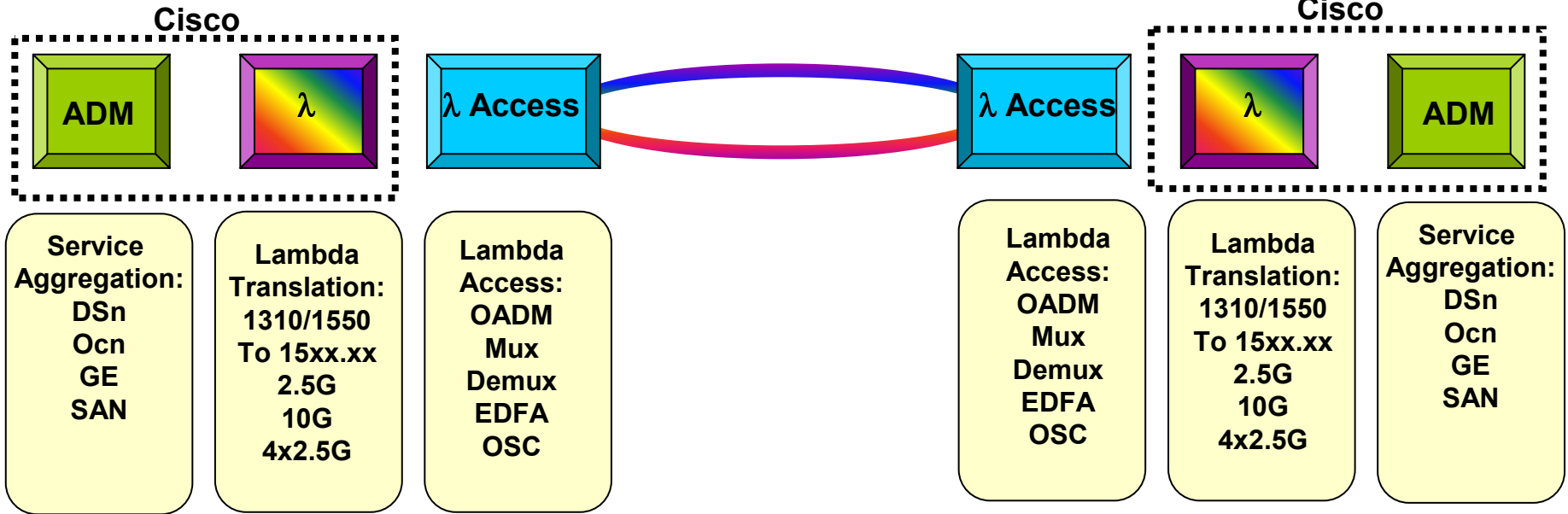

Cisco Metro Regional DWDM Approach: Eliminating Complexity

Cisco.com

Cisco Plan

Cisco Plan

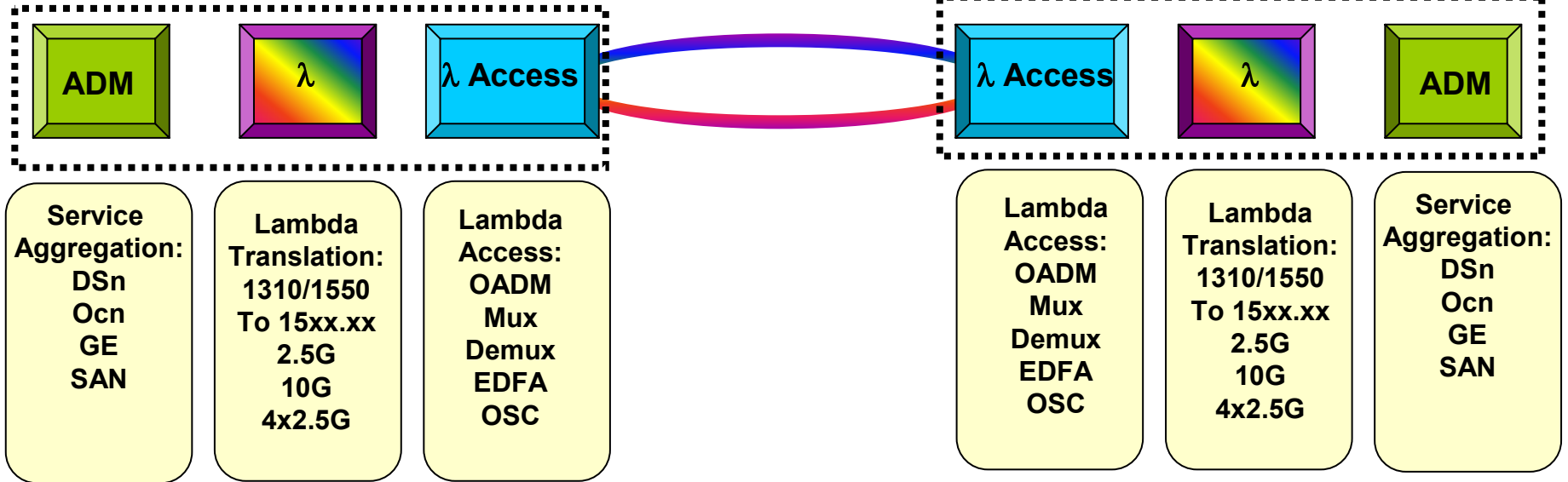

Leveraging 'Simple, Fast, Easy' MSP architecture pioneered by Cisco®

- Easy channel and capacity planning
- Reliable network design and management of NE's

Carrier-Class Reliability

- **Cisco ONS 15454 MSTP carrier-class reliability features:**
 - **Fast transient suppression on amplifiers to ensure continued operation in face of other channel failures and churn**
 - **Special support for the effects of aging in the network**
 - **Complete visibility into power levels at every card for fast troubleshooting**
 - **Various optical protection schemes to cover the spectrum between high availability and low cost**
 - **Dual controllers and OSC cards for continuous OAM&P**

Customer Value: Efficient bandwidth usage for any distributed traffic pattern

Cisco ONS 15454 MSTP

- **Multiservice Aggregation**

 - Ultimate wavelength density via multiservice wavelengths!

 - WDM is now a design option of MSPP

 - Eliminates need for stand-alone WDM platforms

- **Wavelength Aggregation & Transport**

 - Wavelength services

 - Transparent transport

 - Storage transport; Synchronous environments

- **DWDM Transmission**

 - Transmission layer that scales from metro IOF to regional networks

 - Flexible OADM design options that allow for focus on cost, growth or scalability



Carrier Class DWDM

Addressing Applications from Access to Regional Networks

Terminal IOF Chain (same reach as ring)

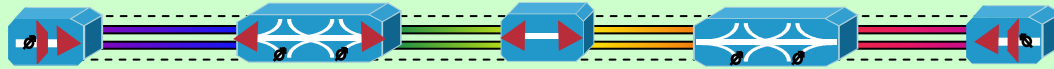

Single span (120 km)

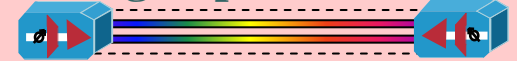

Point-to-point line (600 km)

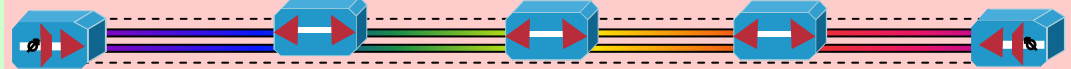

IOF Ring
(300 km for 3 nodes –
600 km for 8 nodes)

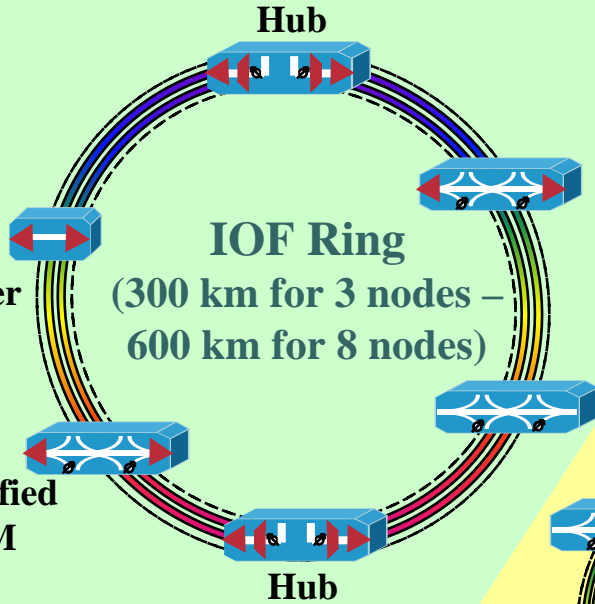

Access Ring
(50 km for 5 nodes)

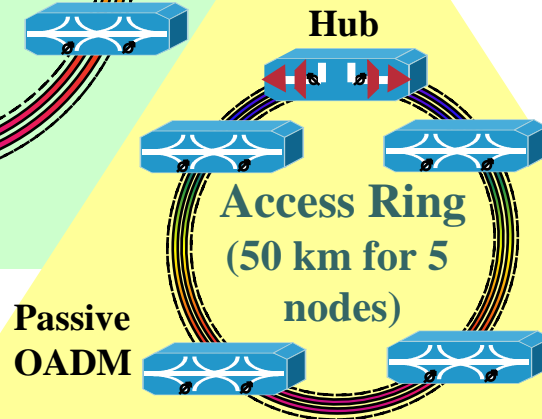

Metro Core
(900 km, 15 nodes)

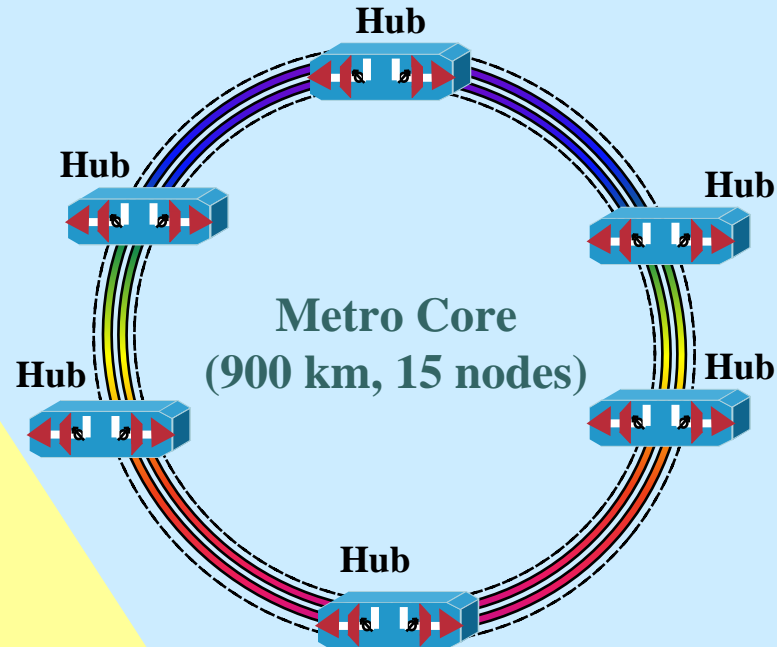

Customer Value: Optimized for many applications → CapEx, single technology → OpEx

Carrier-Class OAM&P Support

Cisco.com

- **Cisco ONS 15454 MSTP carrier-class OAM&P features:**
 - Automated network setup—planning to provisioning
 - Autodiscovery of network topology—Cisco Transport Manager always in sync
 - Automated wavelength additions throughout the network
 - Common management: MSPP, MSSP, and MSTP
 - Easy A-Z point-and-click provisioning
 - Full transparency to SONET overhead via use of G.709 wrappers
 - Reduced inventory via use of tunable lasers
 - ETSI and ANSI compliant—solution for global deployment

Customer Value: SONET/SDH-like ease of use and installation → OpEx advantage

Accommodate Unforeseen Traffic Needs; Deal with Inaccurate Forecasts

- **Fact**: Traffic forecasts are inaccurate
- **Challenge**: Designing optical layer to support unknown traffic without hit on existing traffic
- **Solution**: Flexible add/drop
 - **Hub nodes**: Fully future proof due to full mux/demux
 - **Wavelength-level add/drop at OADM**: Allows client ring to terminate at a middle location without affecting other wavelengths
 - **Band-level add/drop at OADM**: Allows bandwidth reservation around ring without knowledge off add/drop points → open it at A and Z later
 - **Network planning support**: Specify future traffic needs in the tool and automatically design network to meet these

Red wavelength can be dropped at any of these sites in the future without affecting other wavelengths

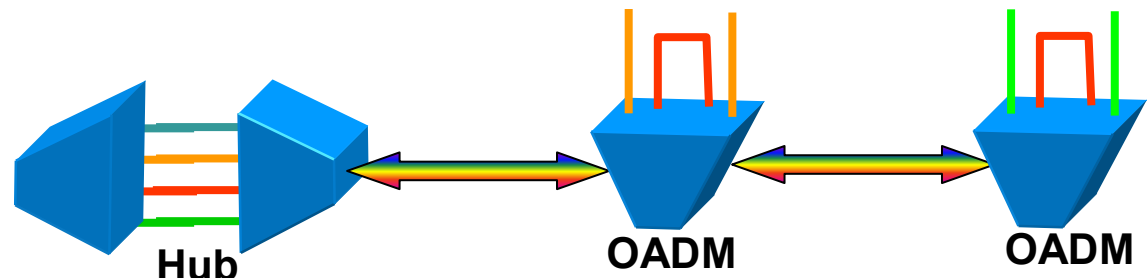

Cisco ONS 15454 MSTP Target Customer Networks

Cisco.com

Enterprise Networks

- Enterprise Managed Network
- Service Provider, Managed Service

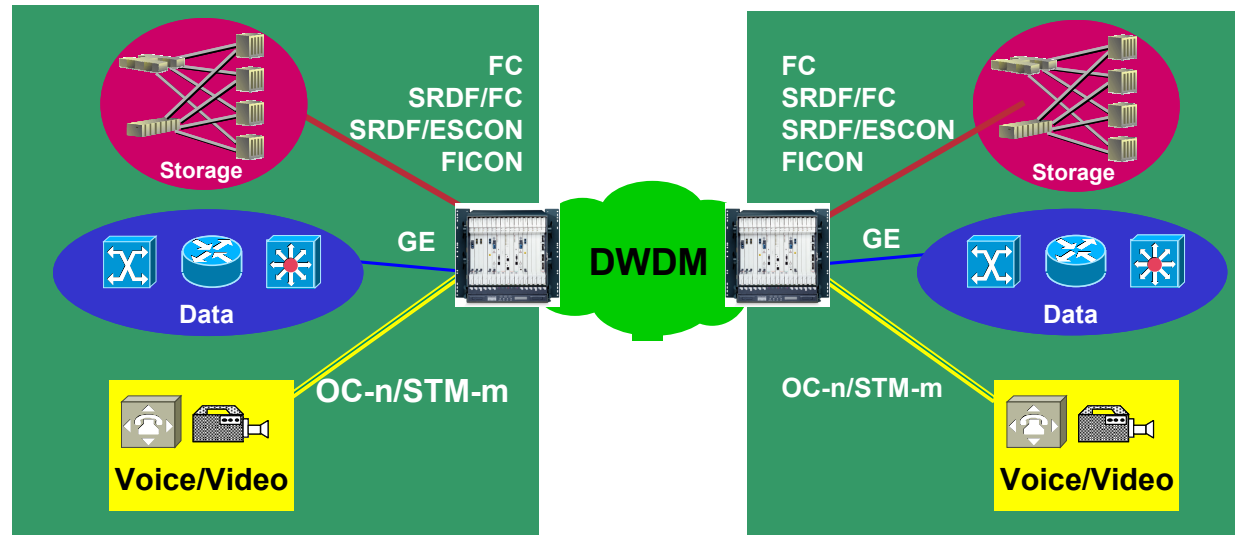

Carrier Networks

- MON – Metro Optical Networks
- Span Exhaust / Fiber Relief
- International Metro, Regional & Long Haul
- Core/IOF – Metro Regional WDM Networks

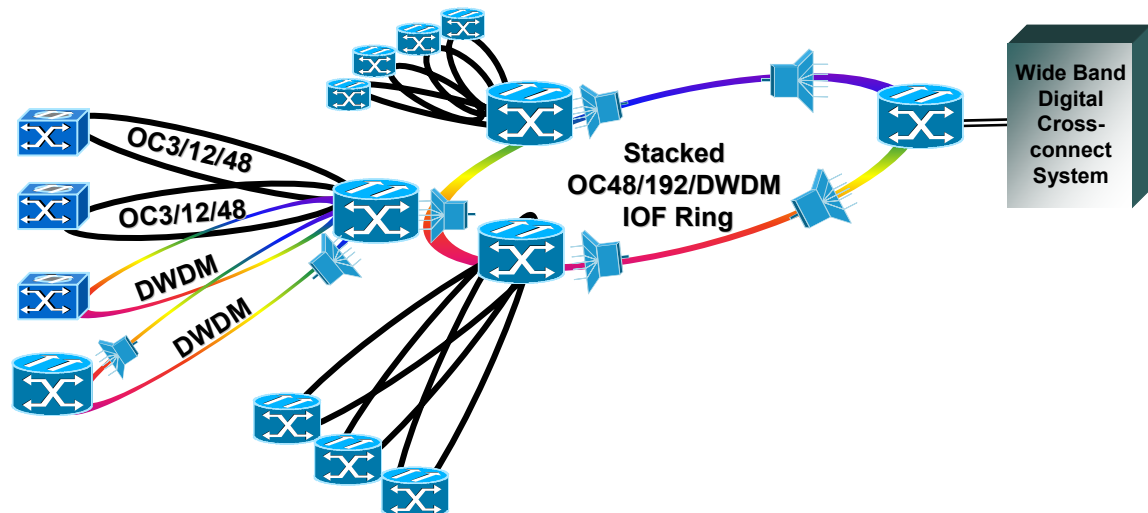

Cisco ONS 15454 MSTP Multiservice Aggregation

Cisco.com

32λ 100GHz ITU Interfaces

32 wavelengths today, 64 at 50 GHz planned

- OC-48 DWDM ITU
- OC-192 DWDM ITU

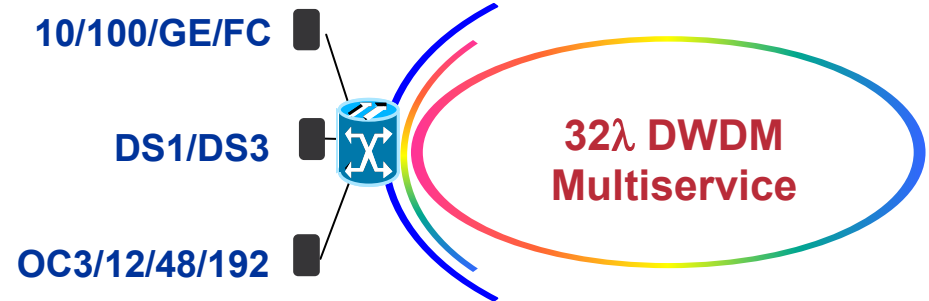

Highly Efficient Transport of Aggregated Services

DS1/E1 to OC-192/STM-64

Ethernet from 1Mbps to 1Gbps

Supports SONET Protocols

1+1 APS, UPSR, 2F-/4F-BLSR, PPMN

High Capacity

Universal slots may be used for wavelength,
packet or TDM services

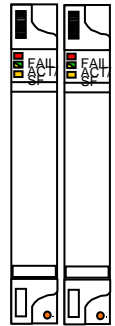

Cisco ONS 15454 MSTP Wavelength Aggregation & Transport

Cisco.com

Transponders & Muxponders

32 wavelengths today, 64 at 50 GHz planned
SW provisionable tunable lasers
Rich Service mix Storage, TDM & Data!

- **10G Multi-Rate Transponder**
 - OC-192/STM-64, 10GE LAN, 10GE WAN
- **4xOC48 10G Muxponder**
 - 4 x OC-48/STM-16
- **2.5G Multi-Rate Transponder**
 - 3R: OC-3/12/48, STM-1/4/16 GE, FC/2GFC, FICON
 - 2R (ESCON D1/SDI, DV6000)
 - Protected and Unprotected
- **2.5G ESCON/GE/FC Muxponder**
 - 8 port DWDM muxponder
 - 8 x ESCON, 2 x 1G FC, 2G FC, 2x 1GE; ISC1/3,
- **GE Transponder – EDGE WDM**
 - 4 port Transponder with GE Monitoring
 - Unidirectional WDM Transport

12 wavelengths per shelf, providing 120G capacity with 10G interfaces!

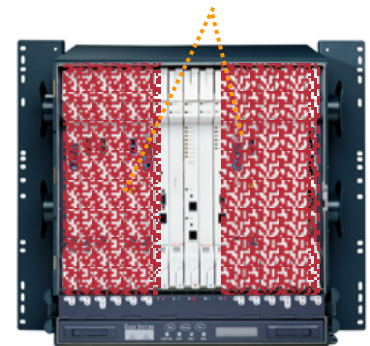
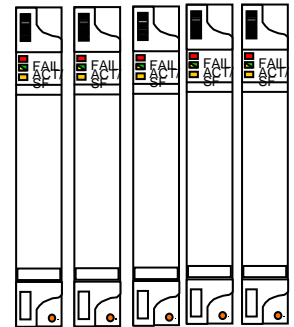

Cisco ONS 15454 MSTP Integrated WDM Transmission

Cisco.com

Integrated Transmission Elements

32 wavelengths today, 64 at 50 GHz planned

- **Multiplexer and De-Multiplexer**
 - 32- λ Multiplexer
 - 32- λ De-Multiplexer
 - 4- λ Multiplexer/Demultiplexer
- **Optical Add/Drop Multiplexer**
 - 1 and 4-Band OADM (Flexible OADM)
 - 1, 2 and 4- λ OADM
- **Optical Amplifier**
 - Optical Pre-Amplifier (EDFA)
 - Optical Booster-Amplifier (EDFA)
- **Optical Service Channel**
 - Optical Service Channel Module (Slots 8 and 10)
 - Optical Service Channel with Combiner/Separator
- **Dispersion Compensation Module (external)**

Any slot installation, providing tremendous flexibility for building DWDM Network Elements

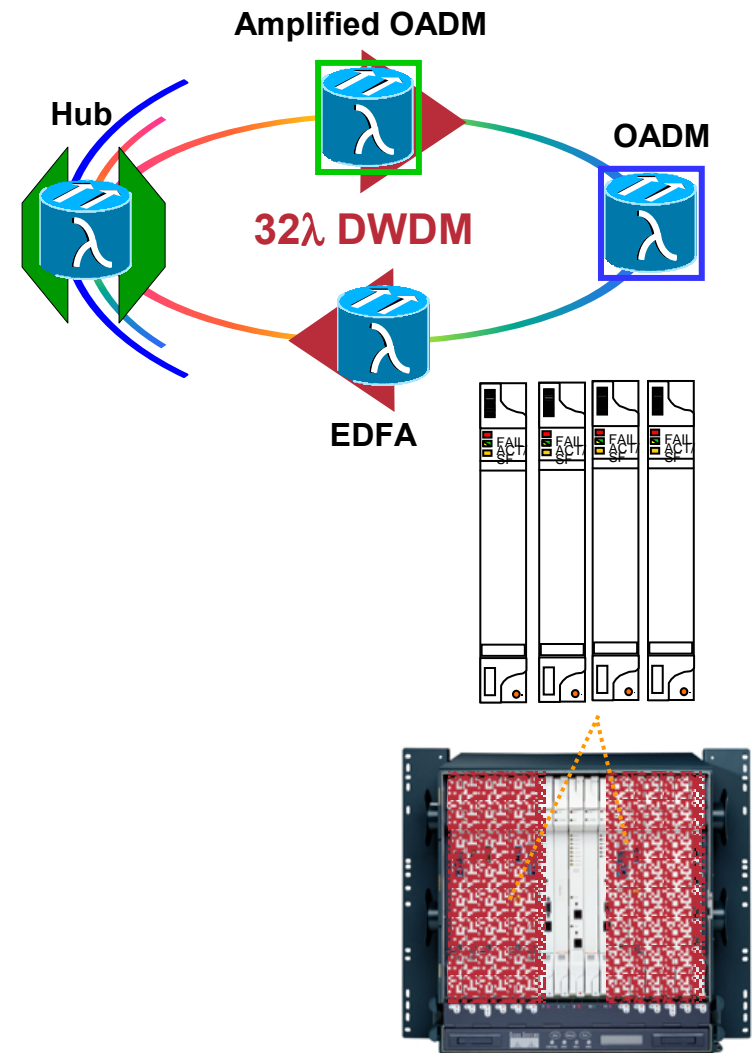

ONS 15454 MSTP:

Network Control Architecture

ONS 15454 MSTP Management Features

Cisco.com



ONS 15454 MSTP

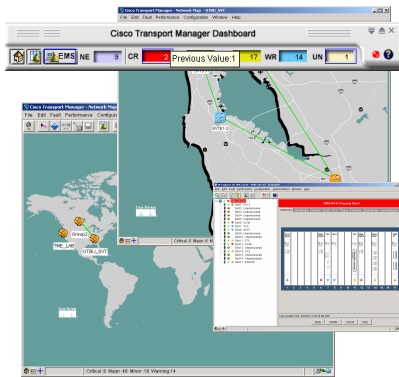
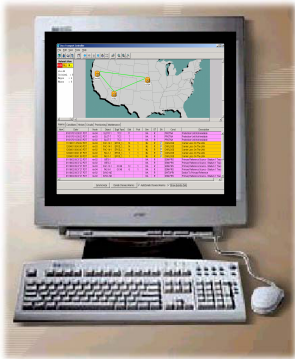

Cisco Transport Controller

Cisco Transport Manager

- **Cisco Transport Controller**
 - Revolutionary craft system
 - Installation and setup
 - Full node/ring management capability
- **Cisco Transport Manager**
 - EMS/NMS Layer applications for Advanced Optical Management
 - CORBA/TL1 and SNMP NBI available for OOS integration
- **Cisco MetroPlanner**
 - Network Design tool application
- **Intelligent Optical Transmission**
 - Automatic Power Control
 - Automatic Node setup
- **Full FCAPS for OTN and SONET/SDH**
 - OTN g.709 and SONET/SDH PM
 - DWDM Fault Management
 - TL1 and SNMP interface to OOS
- **Carrier Class future proof scalable architecture**
- **End To End Wavelength Management**
 - Point and click Optical circuit provisioning with selectable bit-rate
 - FCAPS available at Optical circuit level
 - Optical protection support
- **OSMINE certified**
 - TIRKS,NMA and TEMS

ONS 15454 MSTP

Intelligent optical Transmission

Cisco.com

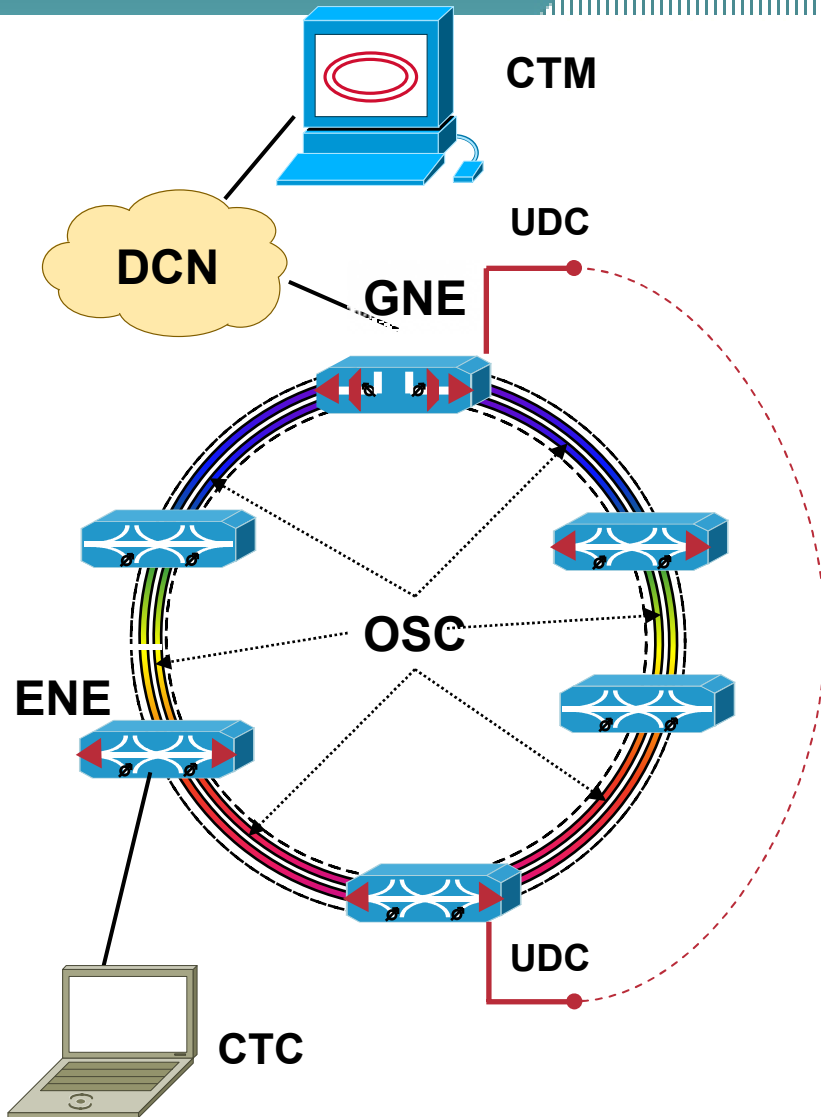

- Sub-network Topology **auto-discovery**
- SONET/SDH Like **Optical connection set up**
- Point and click **Node regulation and set up**
- **Automatic Power Control**
 - ✓ Channel number variation (system upgrade, channel failures)
 - ✓ Ageing effects on fibers/lasers
 - ✓ Operating conditions changing
- FE 100 Mb **User Data Channel** available at each node
- In band G.709 **GCC** available at OCH layer management operations

ONS 15454 MSTP

Automatic power control

Cisco.com

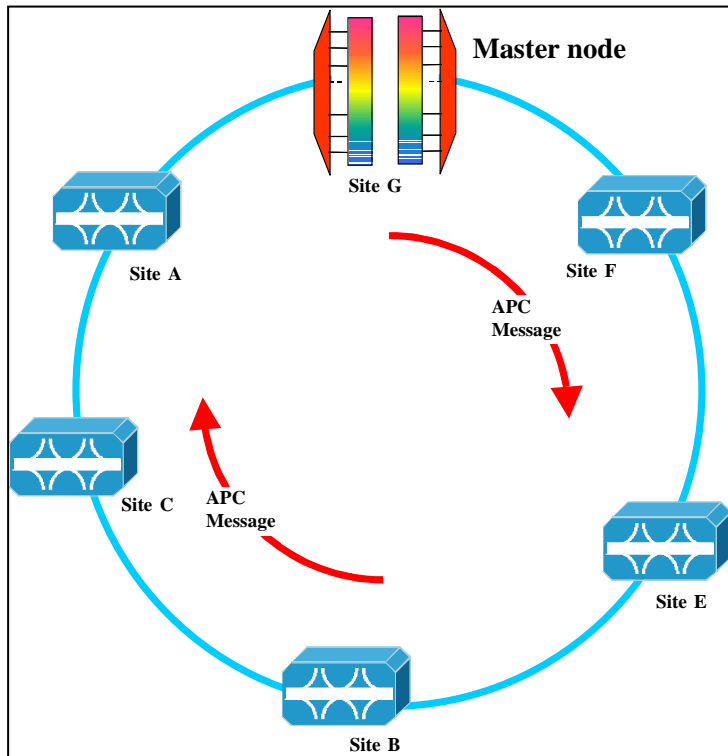

- **Keep** either power or gain constant on each amplifier
- **Avoid** BER or non linear effect
- **APC automatically starts** when network detects needs for a gain correction
- **No human** intervention required
- **Correct** amplifier power/gain
 - whenever the # of channels changes
 - to compensate ageing effects
 - To compensate changing in operating conditions (e.g. temperature increase)

Cisco Transport Controller Revolutionary Craft System

Cisco.com

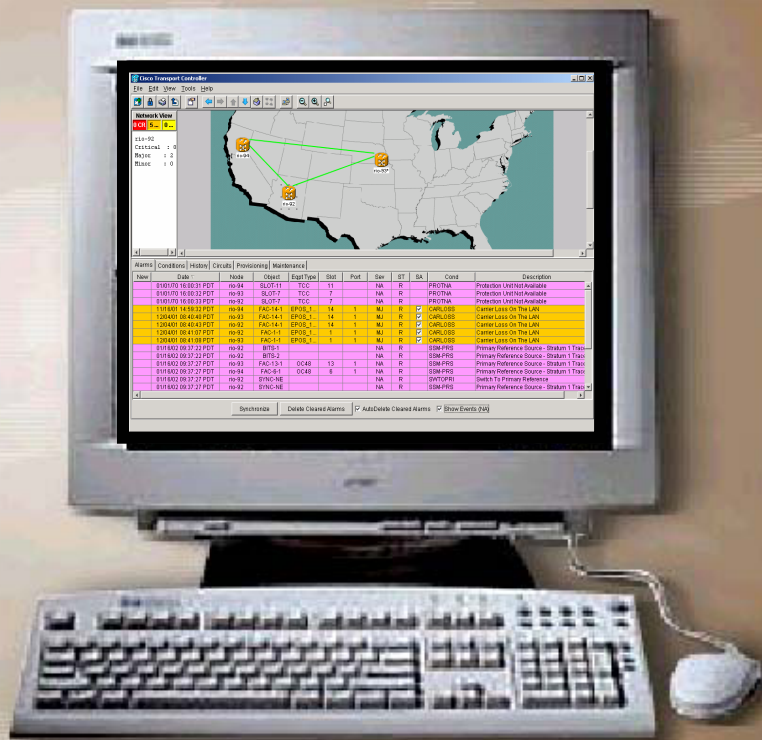

- **Integrated GUI craft system**
GUI available off node and no license needed
- **Auto-discover systems & networks**
- **Breaks the mold of legacy CLI craft interface**
Full GUI; no commands to remember
Manages Subdomain (OSC/GCC) and multiple subdomains
Auto-routed A-Z circuit provisioning
- **Task-oriented tool targeted at**
Installation & turn-up
Maintenance & troubleshooting
Provisioning & control of a subnetwork
Handle transport and data functions

ONS 15454 MSTP:

Network Planning Tool

Metro Planner - Design Objective

- **For a given physical network, find the equipment configuration that:**
 - Ensures Transmission Quality**
 - Accommodates Traffic Growth and Change**
 - Minimizes transmission equipment requirements**
- **Generate all parameters to facilitate MSTP turn up and commissioning**

ONS 15454 MSTP Network Topologies

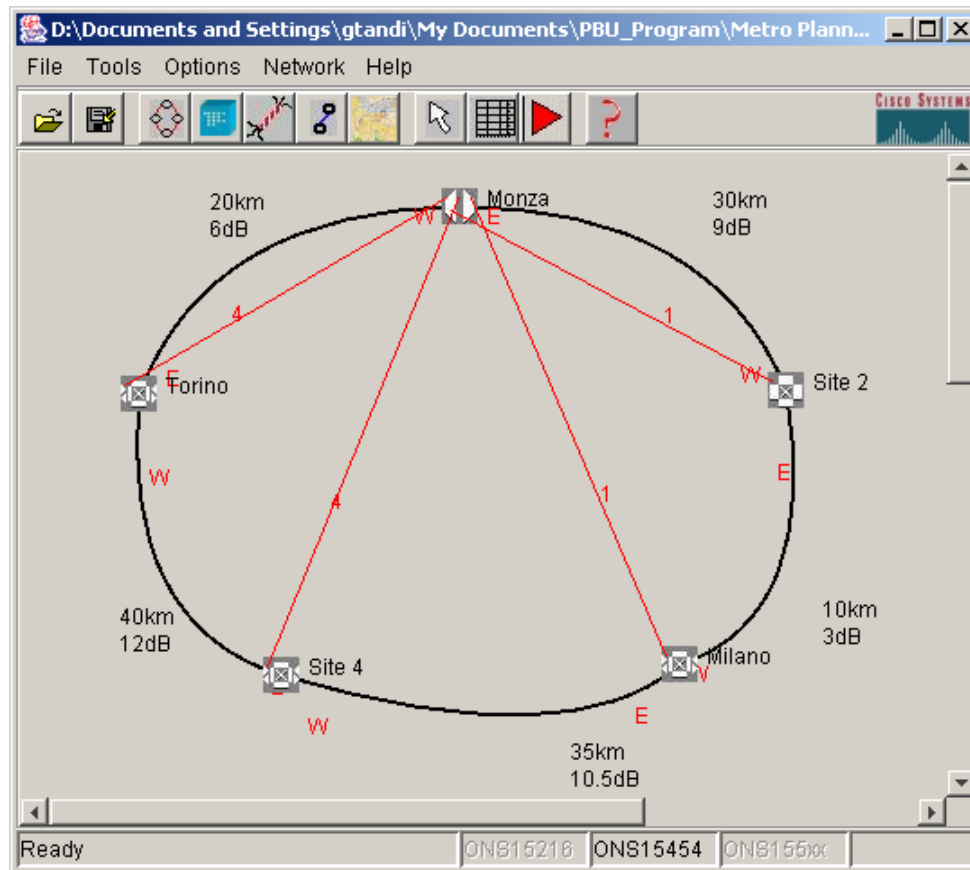

In this network topology a hub node terminates all the DWDM channels. Other configurations are supported, Open Ring case shown here as an example

Analyzer: Network Optical Channel Results

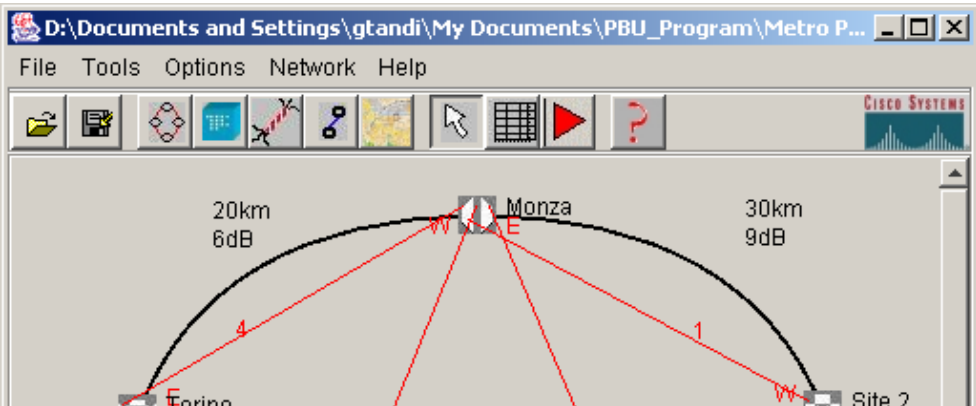

Network Optical Channel Results

Date / Time: 05-15-03 at 08:39:22
 Network Label:
 Version Network Label:

#	SOL	EOL	Srv. Circuit Label	P/F	Source	Dest	Side	Protect	ITU	Span (km)	TX Type	OSNR (dB)	RX (dBm)	BER target	Power margin (dB)	Overload margin (dB)	RX atten.	XTc penalty (dB)	PMD (ps)
1			Monza-Site 2_1_1.1	P/F	Monza	Site 2	East	Unprotected	59.0	30.00	Rockwell-FEC	22.79	-16.90	1.00E-15	5.31	7.12	16.00	0.00	0.10
				P/F	Site 2	Monza	West		59.0	30.00		29.72	-17.20	1.00E-15	5.30	7.70	0.00	1.00	0.10
2			Monza-Site 2_2_1.1	P/F	Monza	Site 2	West	Unprotected	59.0	105.00	Skane 10G	21.05	-13.89	1.00E-15	2.77	4.54	0.00	0.00	0.20
				P/F	Site 2	Monza	East		59.0	105.00		17.33	-13.50	1.00E-15	4.00	5.00	0.00	0.50	0.20
3			Monza-Site 2_3_1.1	P/F	Monza	Site 2	East	Unprotected	58.0	30.00	Rockwell-FEC	22.79	-16.90	1.00E-15	5.31	7.12	16.00	0.00	0.10
				P/F	Site 2	Monza	West		58.0	30.00		29.72	-17.20	1.00E-15	5.30	7.70	0.00	1.00	0.10
4			Monza-Site 2_4_1.1	P/F	Monza	Site 2	West	Unprotected	58.0	105.00	Skane 10G	21.05	-13.89	1.00E-15	2.77	4.54	0.00	0.00	0.20
				P/F	Site 2	Monza	East		58.0	105.00		17.33	-13.50	1.00E-15	4.00	5.00	0.00	0.50	0.20
5			Monza-Milano_1_1.1	P/F	Monza	Milano	East	Unprotected	57.0	40.00	Rockwell-FEC	22.79	-11.51	1.00E-15	10.68	1.69	0.00	0.00	0.14
				P/F	Milano	Monza	West		57.0	40.00		29.72	-17.20	1.00E-15	5.30	7.70	0.00	1.00	0.14
6			Monza-Milano_1_2.1	P/F	Monza	Milano	West	Unprotected	57.0	95.00	Rockwell-FEC	21.05	-16.90	1.00E-15	4.77	6.57	16.00	0.00	0.17
				P/F	Milano	Monza	East		57.0	95.00		17.33	-13.50	1.00E-15	9.00	4.00	0.00	1.00	0.17
7			Monza-Milano_1_3.1	P/F	Monza	Milano	East	Unprotected	56.0	40.00	Rockwell-FEC	22.79	-11.51	1.00E-15	10.68	1.69	0.00	0.00	0.14
				P/F	Milano	Monza	West		56.0	40.00		29.72	-17.20	1.00E-15	5.30	7.70	0.00	1.00	0.14

ONS 15454 MSTP:

Summary

MSTP Summary

- **Provides best-of-breed transmission capabilities:**
 - Extends geographical coverage
 - Supports multiple topologies
 - Delivers on requirements of today’s multiservice environment for a lowest-cost-per-service network
- **Cisco MSTP strategy integrates intelligent photonics into the service platform—next logical step in DWDM evolution**
 - Reduces OpEx
 - Allows tailoring for MSPP architectures, pure DWDM architectures, or mixed-application sets
 - Delivers “least cost per service”
- **Combined with other elements in Cisco COMET portfolio—MSPP, MSSP, and Cisco Transport Manager—MSTP helps service providers meet demands of their service networks**

Recommended Reading

Cisco.com

Cisco Self-Study: Building Cisco Metro Optical Networks (METRO)

ISBN: 1587050706

Available in Aug 2003

Essential Guide to Optical Networks

ISBN: 0130429562

Optical Networks

ISBN: 0130607266

Available on-site at the Cisco Company Store

CISCO SYSTEMS

