



# USP Installation Prerequisites

This chapter contains general installation prerequisites including hardware and software requirements. Though these requirements will support various deployment scenarios, the requirements for your specific use case and deployment scenario may differ.

- [Ultra M Deployments Using UAS, on page 1](#)
- [VNF Deployments Using AutoVNF, on page 5](#)

## Ultra M Deployments Using UAS

### Virtual Machine Recommendations

[Table 1: Minimum VM Sizing Recommendations, on page 1](#) lists the minimum recommended VM sizing configurations per VNF component. Your specific requirements for CF and SF VM sizing may vary based on your deployment scenario.

**Table 1: Minimum VM Sizing Recommendations**

Functions	Minimum Required	vCPU	RAM (GB)	Root Disk (GB)
OSP-D*	1	16	32	200
AutoIT	1**	2	8	80
AutoDeploy	1**	2	8	80
AutoVNF	2	2	4	40
ESC (VNFM)	2	2	8	40
UEM***	2	2	4	40
CF	2	8	16	6
SF	3	12	16	6

Functions	Minimum Required	vCPU	RAM (GB)	Root Disk (GB)
<p>* OSP-D is deployed as a VM within the Ultra M solution. Though the recommended root disk size is 200GB, additional space can be allocated if available.</p> <p>** AutoIT and AutoDeploy each minimally require 1 VM when deployed in non-HA mode. When deployed with HA, each requires 2 VMs.</p> <p>*** UEM VM requirement is dependent on VNFD configuration. It can be either 2 or 3 instances.</p>				



**Important** Ultra M solutions have specific requirements. Refer to the *Ultra M Solutions Guide* for more information.

## Software Requirements

Table 2: [Software Requirements, on page 2](#) identifies the software that must be installed on the prerequisite hardware before installing the USP.

**Table 2: Software Requirements**

Purpose	Software
RedHat Enterprise Linux	Release 6.1 and earlier: RedHat 7.3 Release 6.2.x: RedHat 7.4 Release 6.2.bx: RedHat 7.5 Release 6.3 through Release 6.8: RedHat 7.5 Release 6.9 and later: RedHat 7.5 or RedHat 7.6
Virtual Infrastructure Manager (VIM)	<b>Hyper-Converged Ultra M Single and Multi-VNF Models:</b> RedHat OpenStack Platform 10 (OSP 10 - Newton) or RedHat OpenStack Platform 13 (OSP 13 - Queens)
VIM Orchestrator	<b>Hyper-converged Ultra M Single and Multi-VNF Models:</b> RedHat OpenStack Platform 10 (OSP 10 - Newton) or RedHat OpenStack Platform 13 (OSP 13 - Queens)
UAS Component Operating System	Release 6.3 and earlier: Ubuntu 14.04 Release 6.4 and later: Ubuntu 16.04

In addition to the preceding software, it is assumed that you have downloaded the latest USP software ISO.

# Hardware Requirements

## Server Functions and Quantities

The servers host the VMs required by the USP-based VNF. Though server functions and quantity differ depending on your deployment scenario, the following server functions are required for use with UAS in this release:

- **Ultra M Manager Node:** Required only for Ultra M deployments based on the Hyper-Converged architecture, this server hosts the following:
  - AutoIT VM(s)
  - AutoDeploy VM(s)
  - OSP-D VM



---

**Important** When AutoIT and/or AutoDeploy are deployed in HA mode, both the active and redundant VMs are deployed on the same physical server.

---

- **OpenStack Controller Nodes:** These servers host the high availability (HA) cluster that serves as the VIM. In addition, they facilitate the Ceph storage monitor function required by the OSD Compute Nodes.
- **OSD Compute Nodes:** Required only for deployments based on the Hyper-Converged architecture, these servers containing a Ceph Object Storage Daemon (OSD) providing storage capacity for the VNF. In addition to hosting the following:

[Table 3: Server Quantities by Function, on page 3](#) provides information on server quantity requirements per function. Your specific server/node requirements may vary based on your deployment scenario.

**Table 3: Server Quantities by Function**

Server Quantity (min)	Ultra M Manager Node	Controller Nodes	OSD Compute Nodes	Compute Nodes (min)	Additional Specifications
15	1	3	3	8	Based on node type as described in <a href="#">Table 4: Minimum Server Specifications by Node Type, on page 3</a> .

**Table 4: Minimum Server Specifications by Node Type**

Node Type	CPU	RAM	Storage
Ultra M Manager Node	2x 2.60 GHz	4x 32GB DDR4-2400-MHz RDIMM/PC4	2x 1.2 TB 12G SAS HDD
Controller	2x 2.60 GHz	4x 32GB DDR4-2400-MHz RDIMM/PC4	2x 1.2 TB 12G SAS HDD

Node Type	CPU	RAM	Storage
Compute	2x 2.60 GHz	8x 32GB DDR4-2400-MHz RDIMM/PC4	2x 1.2 TB 12G SAS HDD
OSD Compute	2x 2.60 GHz	8x 32GB DDR4-2400-MHz RDIMM/PC4	4x 1.2 TB 12G SAS HDD 2x 300G 12G SAS HDD HDD 1x 480G 6G SAS SATA SSD

## Password Requirements and Login Security

All passwords configured for and/or through UAS components (AutoIT, AutoDeploy, and/or AutoVNF) and UEM must meet the following criteria:

- They must be a minimum of 8 alpha and/or numeric characters.
- They must contain at least one uppercase letter.
- They must contain at least one lowercase letter.
- They must contain at least one number.
- They must contain at least one special character (e.g. @, #, \$, etc.) with an exception of using exclamation (!) character.
- They must not contain any repetitive alphabets or digits (for example, aaaa, 1111).
- They must not contain any dictionary words.

The specified password criteria is applicable to all deployment scenarios — UAS-based Ultra M deployment, Standalone Auto-VNF-based deployment, and UEM-based VNF deployment.



### Important

UAS and UEM components have password generation tool (apg) to generate random passwords. Use the following commands on UAS or UEM component console to generate password with the preceding constraints:

```
# apg -a 0 -M SNCL -t -E !
```

or

```
# apg -a 1 -M SNCL -t -E !
```

For UAS and UEM components, the following login security restrictions are supported:

- You will be locked out of the system for 10 minutes upon the third incorrect attempt to login to a UAS and UEM VM.
- Should you need/want to change your password, the new password must be different than any of the last five previously configured passwords.

SSH session closes automatically if it is inactive for 5 minutes. Similarly, the CONFD CLI session also closes automatically if it is inactive for 5 minutes.

# VNF Deployments Using AutoVNF

## Virtual Machine Recommendations

[Table 5: Minimum VM Sizing Recommendations, on page 5](#) lists the minimum recommended VM sizing configurations per VNF component. Your specific requirements for CF and SF VM sizing may vary based on your deployment scenario.

**Table 5: Minimum VM Sizing Recommendations**

Functions	Minimum Required	vCPU	RAM (GB)	Root Disk (GB)
AutoVNF	1	2	4	40
ESC (VNFM)*	2	2	8	40
UEM**	2	2	4	40
CF	2	8	16	6
SF	3	12	16	6

\* Though ESC VM sizing recommendations are provided, ESC deployment information and instructions is beyond the scope of this document. Refer to the ESC product documentation for details.

\*\* UEM VM requirement is dependent on VNFD configuration. It can be either 2 or 3 instances.

The VMs identified in [Table 5: Minimum VM Sizing Recommendations, on page 5](#) are deployed in your NFVI as shown in [Figure 1: VM Distribution for VNF Deployments Using AutoVNF, on page 6](#).

Figure 1: VM Distribution for VNF Deployments Using AutoVNF

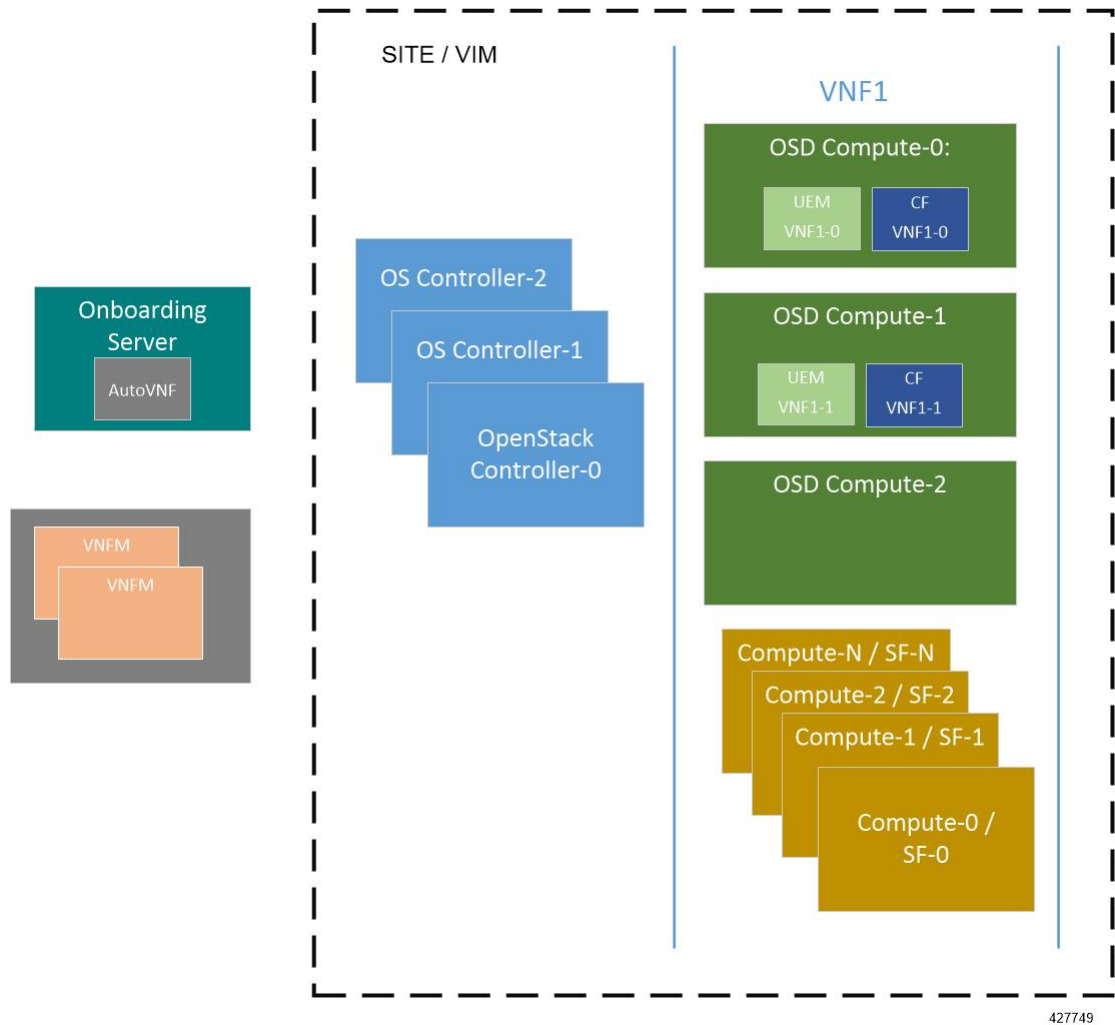

**Note** The above figure depicts an example deployment scenario. The placement of the VMs is based on your deployment requirements.

## Software Requirements

Table 6: Software Requirements, on page 7 identifies the software that must be installed on the prerequisite hardware before installing the USP.

Table 6: Software Requirements

Purpose	Software
Cloud Computing Platform	<p>OpenStack Platform 10 (OSP 10 - Newton) or OpenStack Platform 13 (OSP 13 - Queens)</p> <p><b>Note</b> In releases prior to 6.9, the OpenStack Platform 13 with RHEL 7.5 is validated only for Standalone AutoVNF-based deployments of the UGP VNF.</p> <p><b>Note</b> In release 6.9, the OSP 13 is validated with RHEL 7.6 for all the deployment scenarios.</p> <p><b>Note</b> OpenStack Keystone API versions 2 and 3 are supported. Ensure that all aspects of your deployment are configured to use the same API version.</p>
VNFM	<p>In releases prior to 6.0: Cisco Elastic Services Controller 3.1.0.116</p> <p>In releases 6.0 and 6.1: Cisco Elastic Services Controller 3.1.0.145</p> <p>In release 6.2: Cisco Elastic Services Controller 4.0.0.104</p> <p>In release 6.3: Cisco Elastic Services Controller 4.2</p> <p>In release 6.4 and 6.5: Cisco Elastic Services Controller 4.3.0.121</p> <p>In release 6.6 and release 6.7: Cisco Elastic Services Controller 4.4.0.88</p> <p>In release 6.8 and later: Cisco Elastic Services Controller 4.5.0.112</p>
UAS Component Operating System	<p>In releases prior to 6.3: Ubuntu 14.04</p> <p>In release 6.4 and later: Ubuntu 16.04</p>

In addition to the preceding software, it is assumed that you have downloaded the latest USP software ISO.

## Hardware Requirements

### Server Functions and Quantities

The servers host the VMs required by the USP-based VNF. Though server functions and quantity differ depending on your deployment scenario, the following server functions are required for VNF installation using AutoVNF:

- **Staging Server Node:** This server hosts the AutoVNF VM.
- **OpenStack Controller Nodes:** These servers host the high availability (HA) cluster that serves as the VIM. In addition, they facilitate the Ceph storage monitor function required by the OSD Compute Nodes.

- **OSD Compute Nodes:** Required only for deployments based on the Hyper-Converged architecture, these servers containing a Ceph Object Storage Daemon (OSD) providing storage capacity for the VNF. In addition to hosting the following:
  - Ultra Element Manager (UEM) HA cluster VMs
  - Ultra Service Platform (USP) Control Function (CF) active and standby VMs
- **Compute Nodes:** For all deployments, these servers host the active, standby, and demux USP Service Function (SF) VMs.

**Important**

The above information assumes that the VNFM (ESC) was previously deployed.

[Table 7: Server Quantities by Function, on page 8](#) provides information on server quantity requirements per function. Your specific server/node requirements may vary based on your deployment scenario.

**Table 7: Server Quantities by Function**

Server Quantity (min)	Red Hat Bare Metal/ Staging Server Node	Controller Nodes	OSD Compute Nodes	Compute Nodes (min)	Additional Specifications
15	1	3	3	8	Based on node type as described in <a href="#">Table 8: Minimum Server Specifications by Node Type, on page 8</a> .

**Table 8: Minimum Server Specifications by Node Type**

Node Type	CPU	RAM	Storage
Staging Server	2x 2.60 GHz	4x 32GB DDR4-2400-MHz RDIMM/PC4	2x 1.2 TB 12G SAS HDD
Controller	2x 2.60 GHz	4x 32GB DDR4-2400-MHz RDIMM/PC4	2x 1.2 TB 12G SAS HDD
Compute	2x 2.60 GHz	8x 32GB DDR4-2400-MHz RDIMM/PC4	2x 1.2 TB 12G SAS HDD



Node Type	CPU	RAM	Storage
OSD Compute	2x 2.60 GHz	8x 32GB DDR4-2400-MHz RDIMM/PC4	4x 1.2 TB 12G SAS HDD 2x 300G 12G SAS HDD HDD 1x 480G 6G SAS SATA SSD

## Network Requirements

While specific VNF network requirements are described in the documentation corresponding to the VNF, [Figure 2: Typical USP-based VNF Networks, on page 9](#) displays the types of networks typically required by USP-based VNFs.

**Figure 2: Typical USP-based VNF Networks**

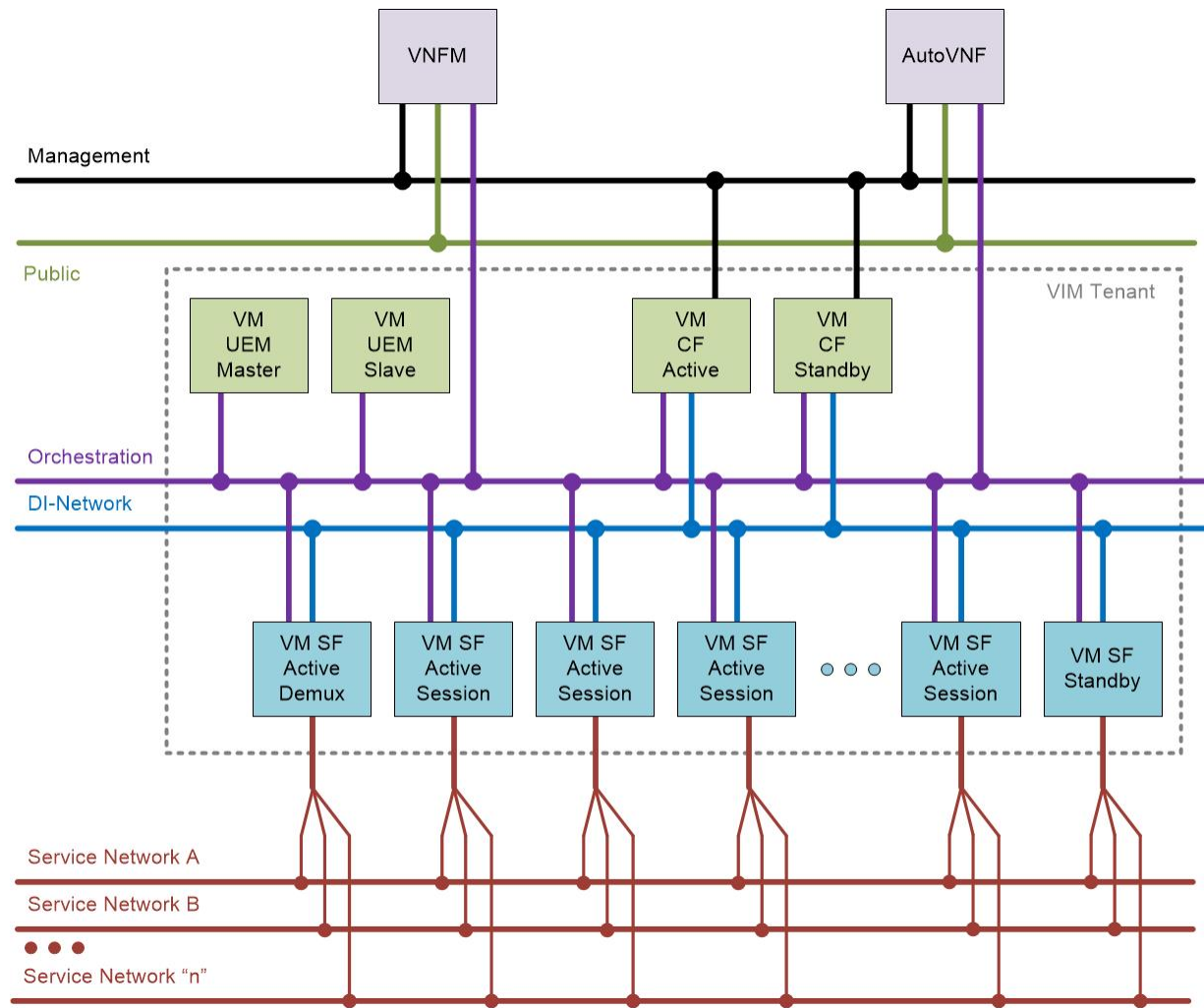

427753

The USP-based VNF networking requirements and the specific roles are described here:

- **Public:** External public network. The router has an external gateway to the public network. All other networks (except DI-Internal and ServiceA-n) have an internal gateway pointing to the router. And the router performs secure network address translation (SNAT).
- **DI-Internal:** This is the DI-internal network which serves as a ‘backplane’ for CF-SF and CF-CF communications. Since this network is internal to the UGP, it does not have a gateway interface to the router in the OpenStack network topology. A unique DI internal network must be created for each instance of the UGP. The interfaces attached to these networks use performance optimizations.
- **Management:** This is the local management network between the CFs and VNFs. To allow external access, an OpenStack floating IP address from the Public network must be associated with the UGP VIP (CF) address.



---

**Note** Prior to assigning floating and virtual IP addresses, make sure that they are not already allocated through OpenStack. If the addresses are already allocated, then they must be freed up for use or you must assign a new IP address that is available in the VIM.

---

- **Orchestration:** This is the network used for VNF deployment and monitoring. It is used by the VNFs to onboard the USP-based VNF.
- **ServiceA-n:** These are the service interfaces to the SF. Up to 12 service interfaces can be provisioned for the SF with this release. The interfaces attached to these networks use performance optimizations.

VNFs can be assigned a floating IP address from a fixed pool of IP addresses configured for each network type. This is done using the **ip-allocation-pool** parameter in the Virtual Link Descriptor’s Network Descriptor. Refer to the *Ultra Services Platform NETCONF API Guide* for more information.

## Password Requirements and Login Security

All passwords configured for and/or through UAS components (AutoIT, AutoDeploy, and/or AutoVNF) and UEM must meet the following criteria:

- They must be a minimum of 8 alpha and/or numeric characters.
- They must contain at least one uppercase letter.
- They must contain at least one lowercase letter.
- They must contain at least one number.
- They must contain at least one special character (e.g. @, #, \$, etc.) with an exception of using exclamation (!) character.
- They must not contain any repetitive alphabets or digits (for example, aaaa, 1111).
- They must not contain any dictionary words.

The specified password criteria is applicable to all deployment scenarios — UAS-based Ultra M deployment, Standalone Auto-VNF-based deployment, and UEM-based VNF deployment.

**Important**

UAS and UEM components have password generation tool (apg) to generate random passwords. Use the following commands on UAS or UEM component console to generate password with the preceding constraints:

```
# apg -a 0 -M SNCL -t -E !
```

or

```
# apg -a 1 -M SNCL -t -E !
```

For UAS and UEM components, the following login security restrictions are supported:

- You will be locked out of the system for 10 minutes upon the third incorrect attempt to login to a UAS and UEM VM.
- Should you need/want to change your password, the new password must be different than any of the last five previously configured passwords.

SSH session closes automatically if it is inactive for 5 minutes. Similarly, the CONF D CLI session also closes automatically if it is inactive for 5 minutes.

