



Applications

- Core UC Applications and Integrations, on page 1
- IP Multimedia Subsystem Network Architecture and Components, on page 3
- Video Call Flow in HCS Deployments, on page 4
- Fax, on page 7
- Cisco Webex Meetings - Cisco HCS Deployment, on page 8
- Cisco Webex Cloud Connected Audio , on page 8
- Mobility, on page 12
- Cisco Hosted Collaboration Mediation Fulfillment Impact, on page 22
- Cisco Collaboration Clients and Applications, on page 22
- Endpoints - Conference, on page 23
- Directory, on page 23
- Client Services Framework – Dial Plan Considerations, on page 25
- Translation Patterns, on page 25
- Application Dialing Rules, on page 25
- Directory Lookup Rules, on page 25
- Client Transformation, on page 26
- Deploying Client Services Framework, on page 26
- Deployment Models for Jabber Clients, on page 26
- Push Notifications, on page 27
- Cisco Webex Hybrid Services Architecture Overview, on page 27
- Cisco Cloud Collaboration Management, on page 27

Core UC Applications and Integrations

Cisco Unified Communications Manager (CUCM)

Cisco Unified Communications Manager (Unified CM) provides reliable, secure, scalable, and manageable call control and session management. Consolidate your communications infrastructure and enable your people and teams to communicate simply with IP telephony, high-definition video, unified messaging, instant messaging and presence.

For more information, see the CUCM documentation: <https://www.cisco.com/c/en/us/support/unified-communications/unified-communications-manager-version-12-5/model.html>

Cisco Unity Connection (CUC)

Cisco Unity Connection is a robust unified messaging and voicemail solution that provides users with flexible message access options and IT with management simplicity.

For more information, see the CUC documentation: <https://www.cisco.com/c/en/us/support/unified-communications/unity-connection/tsd-products-support-series-home.html>

Cisco Emergency Responder (CER)

Coupled with Cisco Unified Communications Manager, Cisco Emergency Responder surpasses traditional PBX capabilities by introducing user or phone moves and changes at no cost, and dynamic tracking of user and phone locations for emergency 9-1-1 safety and security purposes.

For more information, see the CER documentation: <https://www.cisco.com/c/en/us/support/unified-communications/emergency-responder/tsd-products-support-series-home.html>

Cisco Unified Attendant Console (CUAC)

Cisco Unified Attendant Consoles (UACs) can help you ensure that your teams handle all calls efficiently and professionally. CUACs combine superior call routing and distribution tools with support for Cisco Unified IP Phones and Unified Communications Manager. You may choose the standard or advanced option depending on scale requirements.

Standard version documentation: <https://www.cisco.com/c/en/us/support/unified-communications/jabber-windows/products-installation-guides-list.html><https://www.cisco.com/c/en/us/support/unified-communications/unified-attendant-console-standard/model.html>

Advanced version documentation: <https://www.cisco.com/c/en/us/support/unified-communications/unified-attendant-console-advanced/model.html>

Cisco Expressway

Cisco Expressway offers users outside your firewall simple, highly secure access to all collaboration workloads, including video, voice, content, IM, and presence. Users can collaborate with people who are on third-party systems and endpoints or in other companies; teleworkers and Cisco Jabber mobile users can work more effectively on their device of choice.

For more information, see the Cisco Expressway documentation: <https://www.cisco.com/c/en/us/support/unified-communications/expressway-series/tsd-products-support-series-home.html>

Cisco Paging Server

Cisco Paging Server is designed for applications of any size for customers of Cisco Unified Communications Manager. The InformaCast software application offers essential paging functions through Cisco IP Phones with emergency notification capabilities built-in. The solution provides business-critical corporate communications as well as reliable security awareness for many industries.

For more information, see the Cisco Paging Server documentation: <https://www.cisco.com/c/en/us/support/unified-communications/paging-server/tsd-products-support-series-home.html>

IP Multimedia Subsystem Network Architecture and Components

The IP Multimedia Subsystem or IP Multimedia Core Network Subsystem (IMS) is an architectural framework for delivering IP multimedia services. IMS was originally designed by the wireless standards body 3rd Generation Partnership Project (3GPP). Descriptions of the essential IMS network elements referred to in this section and how Cisco Unified Communications Manager functions as an application server (AS) in the IMS network follow.

The high-level topology of an IMS network using Cisco Unified Communications Manager as an application server is shown in the following figure.

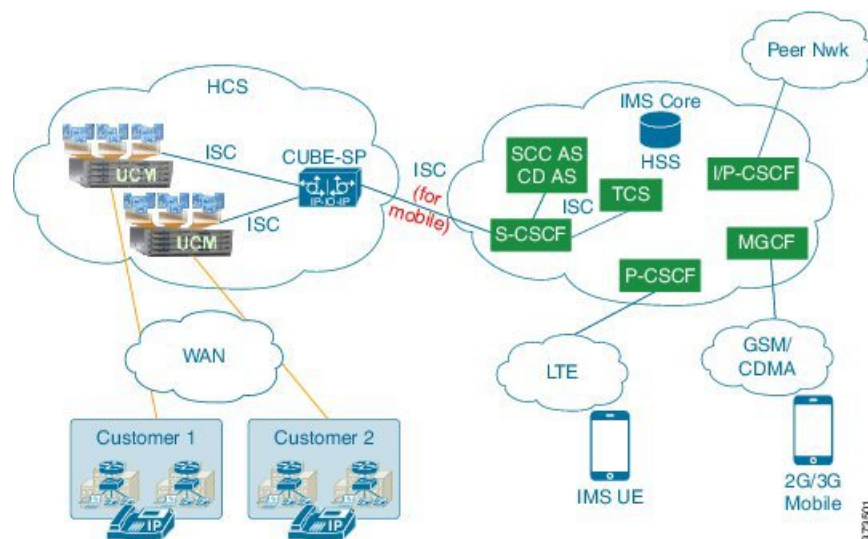

Essential IMS Network Elements

Essential IMS network elements include:

- Home Subscriber Server (HSS), or User Profile Server Function (UPSF)

Master subscriber database that supports the IMS network entities that handle calls. HSS contains subscription-related information (subscriber profiles), performs subscriber authentication and authorization, and can provide information about subscriber locations and IP information. HSS is similar to the GSM Home Location Register (HLR).

- Proxy Call Session Control Function (P-CSCF)

Session Initiation Protocol (SIP) proxy that is the first point of contact for the IMS terminal. P-CSCF can be in the SBC, but is not in our application.

- Serving-CSCF (S-CSCF)

The central node in the signaling plane. S-CSCF provides routing services, typically using electronic numbering (ENUM) lookups, and handles SIP registrations that enable S-CSCF to bind the user location (the IP address of the IMS terminal) and the SIP address.

- Interrogating-CSCF (I-CSCF)

The P-CSCF forwards registration requests to an I-CSCF, which interrogates HSS to obtain the address of the relevant S-CSCF to process the SIP initiation request. For call processing, SIP requests are sent to I-CSCF.

- SIP application servers (AS)

Servers that host and execute services and interface with the S-CSCF using SIP.CUCM) functions as an AS in the configuration via an ISC interface.

Video Call Flow in HCS Deployments

Intra-Enterprise Point-to-Point Video Calling

Point-to-point video calling is supported for all the video endpoints supported on Unified Communications Manager.

Figure 1: Intra-Enterprise Call

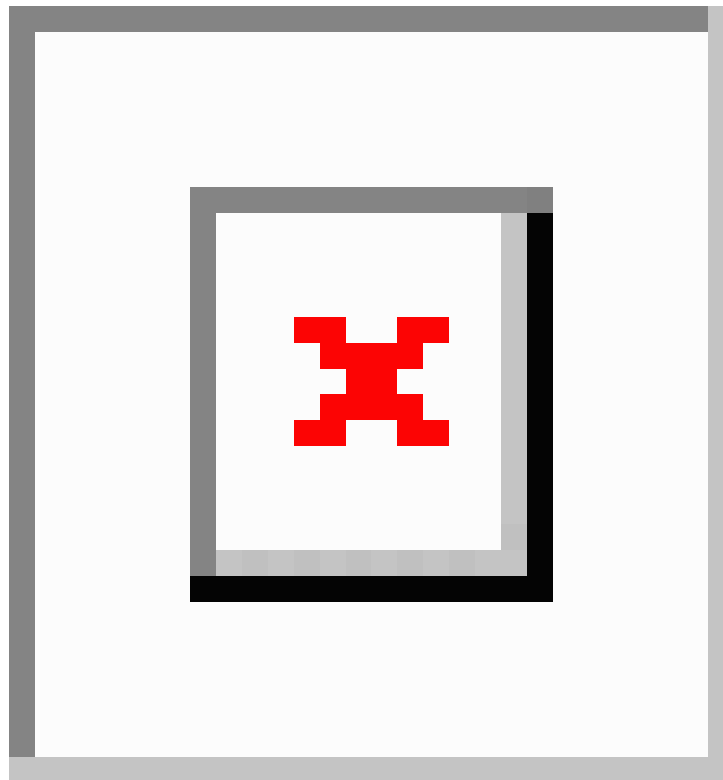

HCS Hosted Inter-Enterprise Point-to-Point Video Calling

In Cisco HCS all inter-enterprise calls are routed through the aggregation layer with the SBC providing the demarcation point. From the leaf cluster perspective, the video calls are handled the same way as intra-enterprise

calls. However, the trunks carrying video traffic to and from the SBC need to be appropriately configured to handle video sessions.

Depending on the service provider, aggregation layer routing options, inter-enterprise audio calls may be hairpinned at the SBC or at a Softswitch in the service provider domain.

Regardless of routing infrastructure within the SP domain, we assume that the SP network preserves the Video SDP (attributes) so that the inter-enterprise audio call can succeed as a video call if both endpoints support Video.

Figure 2: Inter-Enterprise Call

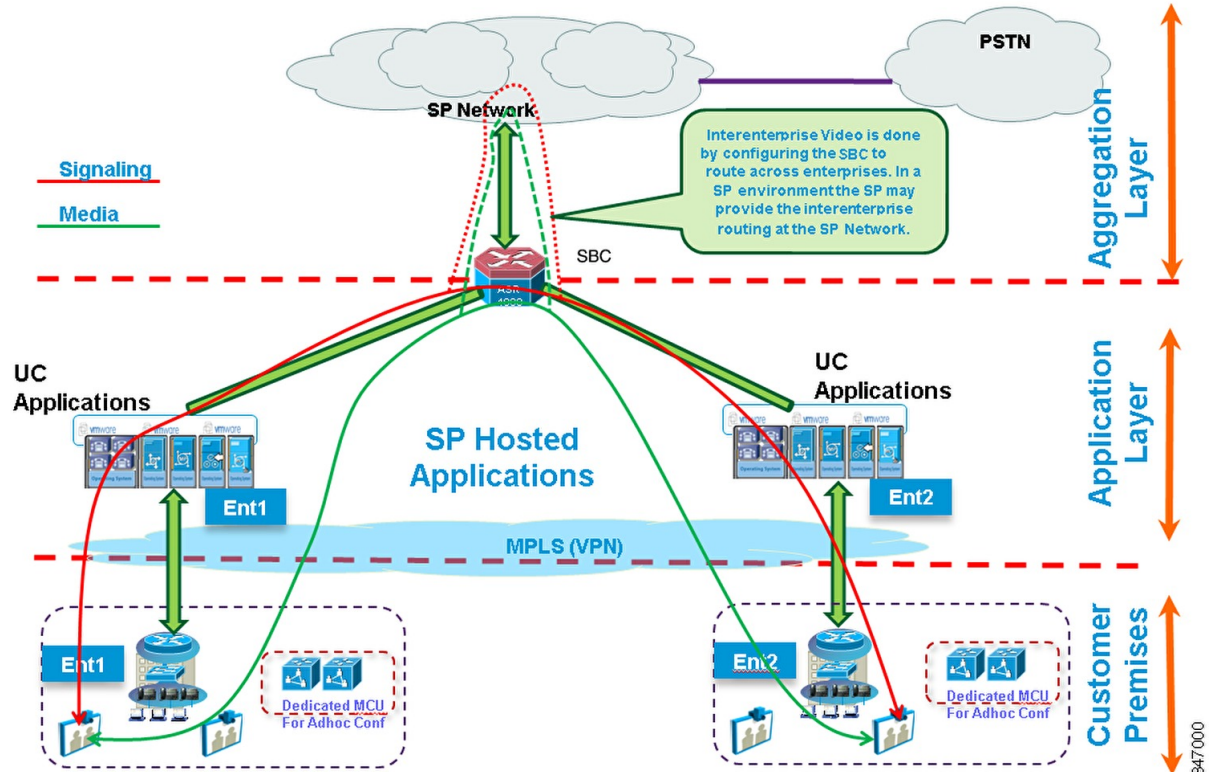

347000

Non-HCS to HCS Enterprise Point-to-Point Video Calling

In Cisco HCS, every call made to a non-Cisco HCS user traverses the SBC that is deployed as the demarcation point between Cisco HCS Customer instance and the aggregation layer. Video calls from non-Cisco HCS users are treated very similarly to an interenterprise call with the assumption that the video SDP will be preserved and compatible for the video sessions. Also all video sessions are expected to be using SIP signaling. The following diagram captures the interconnectivity for non-Cisco HCS Video calls.

Figure 3: Non-Cisco HCS to Cisco HCS Enterprise Call

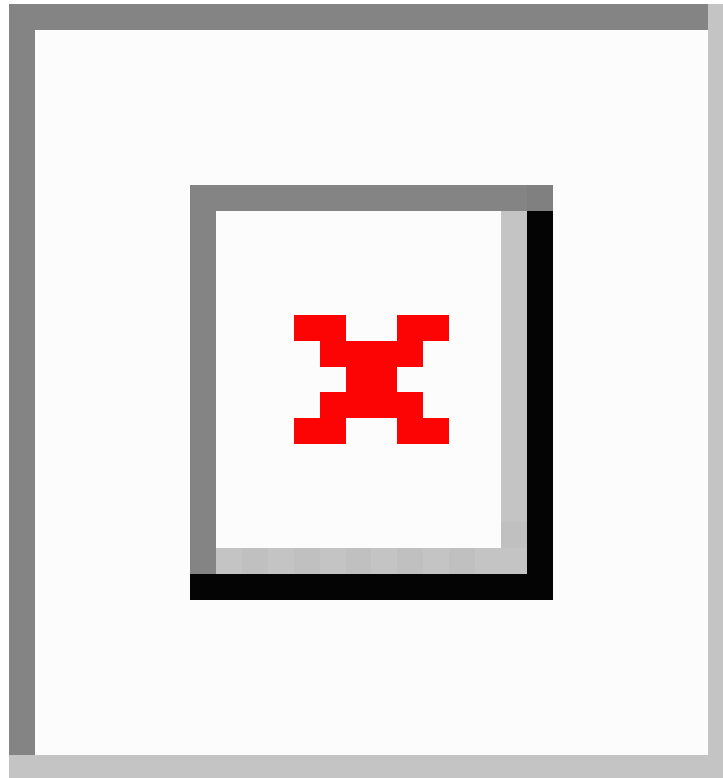

Depending on the SP network and requirements, you can configure an SBC with a dedicated adjacency to the non-Cisco HCS video cloud or the SP network can directly connect to the video cloud and provide the routing across Cisco HCS and non-Cisco HCS video endpoints.

Within Cisco HCS, the SBC is configured to validate the interworking of Non-Cisco HCS Video Signaling. Non-Cisco HCS video signaling includes calls to and from external Cisco TelePresence Systems, which can either be a scheduled or ad hoc meeting on the Cisco TelePresence Systems. However some of the features specific to Cisco TelePresence Systems like One Button To Push are not available on the Video Endpoints registered with the HCS leaf clusters.

HCS Enterprise Video

This following sections focus on HCS enterprise architecture video offerings, which enable external video service interoperability and integration.

The HCS TelePresence network architecture diagram below shows the multiple functions and features provided by the common components along with the connectivity model.

Figure 4: HCS TP Network Architecture

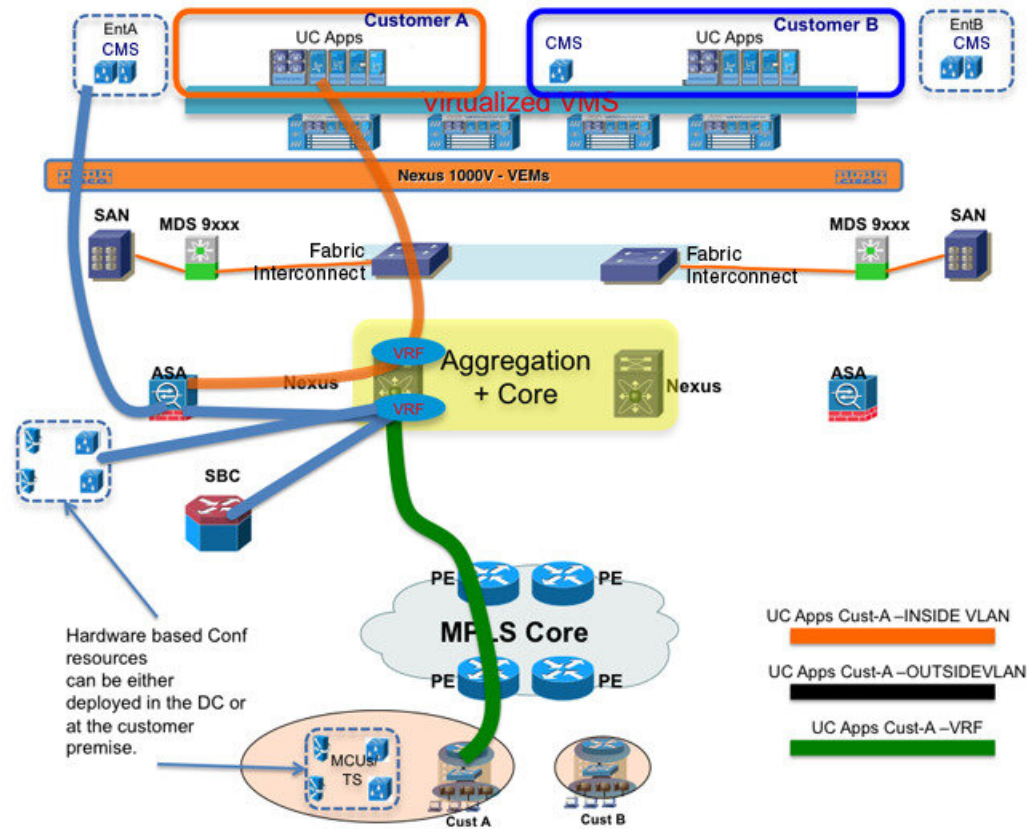

Fax

For most customers, there is a requirement to provide fax service to the end users. This includes inbound fax from the PSTN and outbound Fax to the PSTN and Fax over VoIP between sites.

The fax machines are connected to a VG, which communicates preferably in SIP with the Unified Communications Manager.

Supported Fax Gateways

For a complete list of supported fax models, see the *Cisco Hosted Collaboration Solution Compatibility Matrix*.

Inbound Fax from PSTN

The fax arrives on one of the dedicated DID numbers used for fax.

The call flow is as follows:

- PSTN user dials a managed fax number.

- Call comes in on Broadsoft, then from there is sent to SBC through SIP and from SBC to Unified Communications Manager SIP trunk.
- Unified Communications Manager sends the call to VG based on DN.
- Once the local fax provides fax tone, the fax session is established end-to-end and the fax is received by the local fax.

Outbound Fax to PSTN

Dial the remote fax number to be reached and the fax machine sends the fax out to PSTN over the central breakout.

The call flow is as follows:

- You dial a fax number.
- Call goes out through VG to Unified Communications Manager.
- Unified Communications Manager sends the call to SBC, SBC to Broadsoft, and from Broadsoft then out to PSTN.
- After the remote side provides fax tone, the fax session is established end to end and the fax goes out to the destination.



Note To configure Inbound and Outbound fax from the MGCP gateway, see the <http://www.cisco.com/c/en/us/tech/voice/gateway-protocols/tsd-technology-support-troubleshooting-technotes-list.html> for detailed information.

Fax Within the Customer

End users dial a fax DN or fax public number to reach a dedicated fax machine at another site. This fax call does not go over to PSTN but stays on-net because Unified Communications Manager recognizes the DN as one of the local DN.

Cisco Webex Meetings - Cisco HCS Deployment

Cisco Webex Meetings offers Web-based document/application/desktop sharing as a cloud based Over-The-Top (OTT) pass-through service from Cisco Webex cloud, that is, a Cisco HCS service provider typically does not host any Cisco Webex infrastructure. Cisco Webex Meetings provides collaboration features such as document sharing, application sharing, and desktop sharing. Cisco HCS enables provisioning of Cisco Webex Meetings user accounts through Unified Communications Domain Manager through the Cisco Webex API.

Cisco Webex Cloud Connected Audio

Cisco Webex Cloud Connected Audio enables on premise callers to connect to Cisco Webex audio over IP-based networks using IP-based signaling and media.

Calls received by an SBC or on the PSTN-Webex adjacency are routed out of the WebEx-CCA adjacency. Similarly, call back calls received on Cisco Webex CCA adjacency are routed out of PSTN-Cisco Webex adjacency towards the PSTN provider network. The PSTN network then routes the call to the final destination.

Cisco Webex Cloud Connected Audio allows Cisco Webex enabled enterprises to use native PSTN connectivity instead of using the Cisco Webex PSTN connectivity. Within an SBC, all calls originating from HCS tenants from leaf clusters towards Cisco Webex are routed to the PSTN provider network, which routes the call back to an SBC on a dedicated PSTN-Cisco Webex adjacency. For deployments with LBO, calls still use Cisco Webex PSTN.

This is done by creating a dedicated adjacency towards Cisco Webex. This adjacency is used to send and receive Cisco Webex audio calls from and to users joining Cisco Webex Meetings hosted by HCS tenant enterprises Cisco Webex Meetings. The following diagram captures architecture that will be supported in HCS for integrating/connecting to the Cisco Webex for cloud connected audio feature.

Figure 5: Cisco Webex Collaboration Cloud Audio Architecture

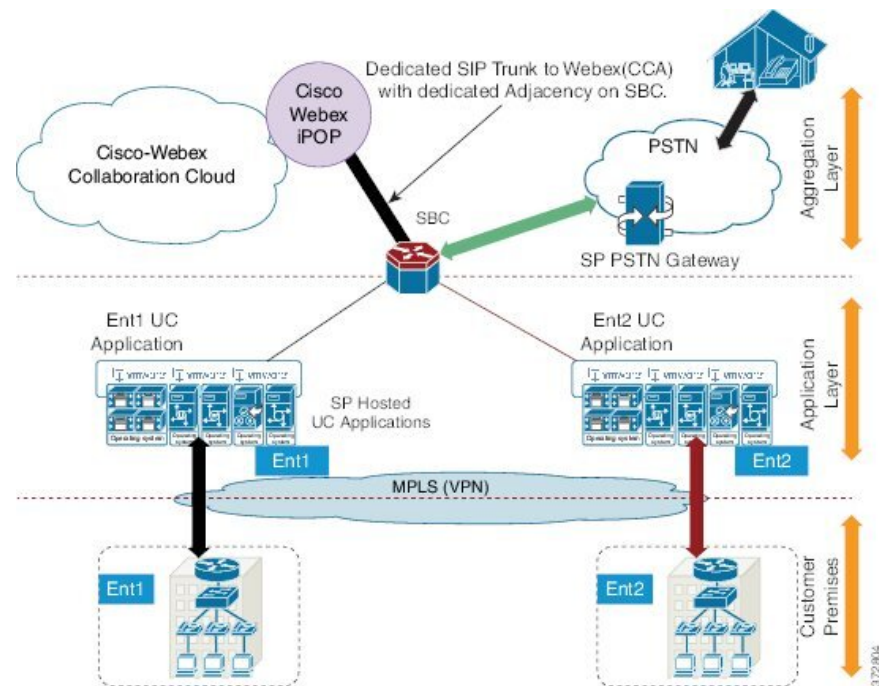

All signaling and media sessions specific to Cisco Webex audio between the leaf clusters and the Cisco Webex are routed through the Session Border Controller (SBC) on the existing sip trunk/Adjacency between leaf clusters and SBC. All Enterprises enabled for Cloud Connected Audio are configured with the same non-disable meeting number and the same or different E.164 numbers on per enterprise basis on Cisco Webex. Cisco Webex uses the meeting IDs to uniquely identify the meeting ownership.

The leaf clusters are configured to route the calls to the Cisco Webex number over the same SIP trunk configured towards the SBC. The SBC is configured to route the calls specific to Cisco Webex number over a shared trunk/adjacency to Cisco Webex. The SBC is configured to uniquely identify the enterprise or Cisco Unified Communications Manager initiating the Cisco Webex audio call.

In the figure below, the SBC hands over the Cisco Webex call to the Service Provider PSTN switch. The service provide PSTN switch does the number analysis and other various routing methodologies to identify the termination of a unique SIP trunk to an SBC for calls destined to Cisco Webex CCA. The SBC determines the destination adjacency is Cisco Webex CCA after receiving calls on this specific adjacency.

For call back calls requested during a specific enterprise hosted session, the Cisco Webex routes the calls to the SBC with additional parameters to uniquely identify the enterprise that needs to handle and complete the call.

For call back calls from Cisco Webex CCA, the SBC hands over all call invites to the service provider PSTN switch. The switch identifies the termination a subscriber under a hosted customer site or PSTN if the user joins a meeting from PSTN or sites that do not have Central Break Out and depend local connection to PSTN.

All non-enterprise users have to dial the enterprise specific Cisco Webex number that is routed through the SBC to the enterprise specific leaf cluster.

These call flows include both signalling and media information as they follow the same path.

Figure 6: Central Breakout for Cisco Webex CCA

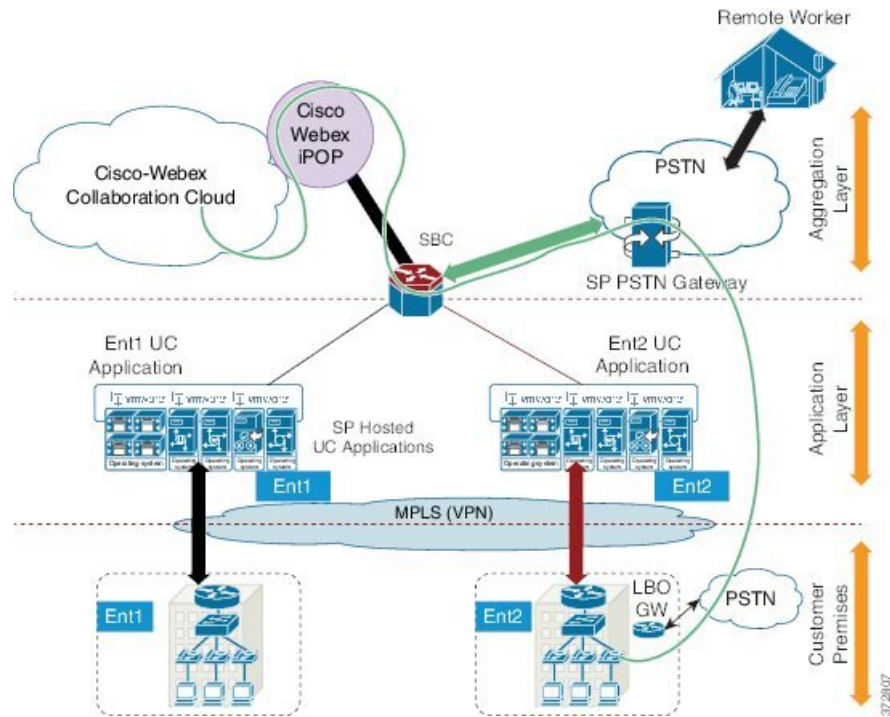

Enterprise User Calls Into Cisco Webex and Calls from Cisco Webex CCA to Enterprise Users

Figure 7: Routing for Hosted Enterprise User Joining a Meeting

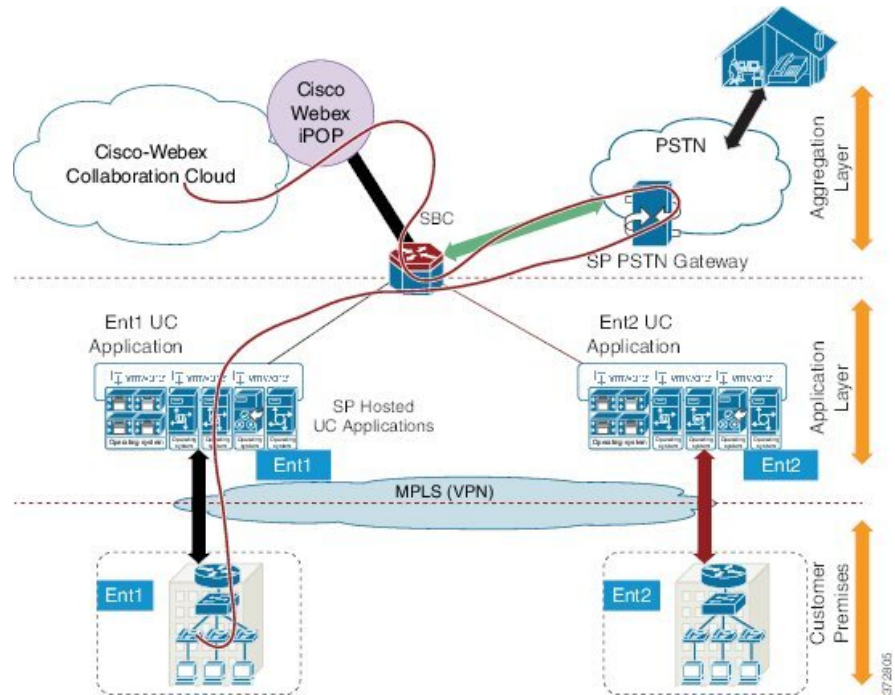

For Dial in:

Depending on the configuration enabled on Cisco Unified Communications Manager, the enterprise users can either dial an enterprise owned e.164 number or an extension dedicated for Cisco Webexaudio sessions. Leaf clusters transform this number to a CCA number and route it to the SBC over existing sip trunks for onward routing to Cisco Webex cloud. The service provider PSTN switch identifies a unique SIP trunk to an SBC to carry all call traffic towards Cisco Webex CCA. The SBC selects the destination adjacency towards Cisco Webex CCA to route the calls.

The Cisco Webex cloud includes additional parameters to uniquely identify the enterprise so that the SBC can route it to the corresponding enterprise for call back calls. This behavior allows the call back calls to be handled by the correct enterprise, regardless of the called user's number or location.

External Users Call into Cisco Webex and Calls from Cisco Webex CCA to External Users

Figure 8: Routing Callbacks Over PSTN

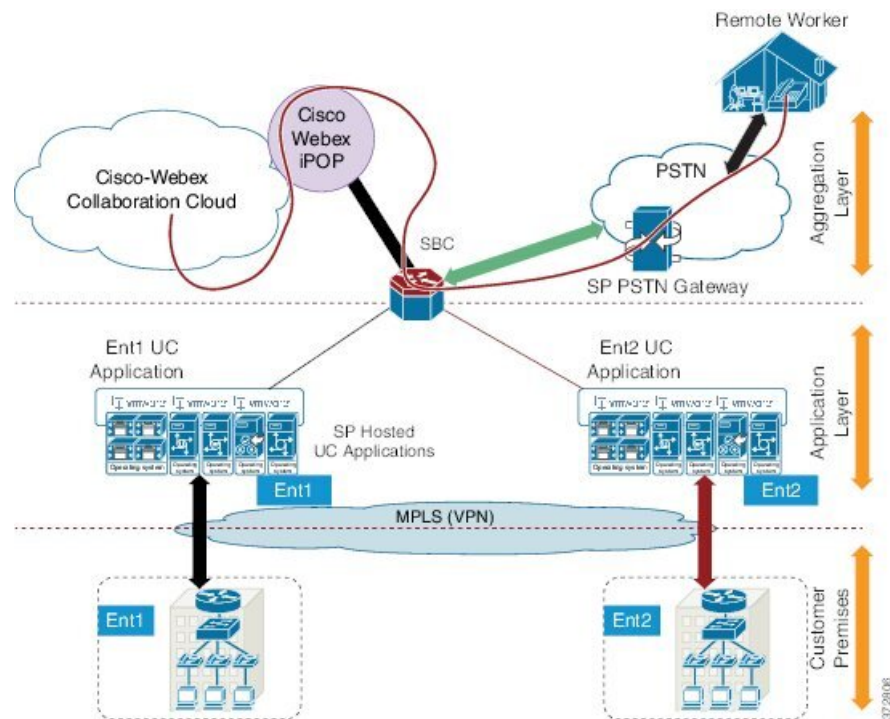

External users can dial an enterprise owned e.164 number dedicated for Cisco Webex audio sessions. When external users from PSTN dial-in to the meeting, the service provide PSTN switch identifies the unique SIP trunk to and SBC for calls destined to Cisco Webex CCA. The SBC routes the call to destination adjacency towards Cisco Webex CCA.

Callback calls from Cisco Webex CCA are handed over to PSTN by the service provider PSTN switch to route to the user joining the meeting. This behavior allows the call back calls to be handled by the correct enterprise, regardless of the called user's number or location.

Mobility

Cisco HCS offers Mobile Unified Communications solutions and applications that deliver features and functionality of the enterprise environment to mobile workers wherever they might be. With Mobile Unified Communications solutions, mobile users can handle business calls on a multitude of devices and access enterprise applications whether moving around the office building, between office buildings, or between geographic locations outside the enterprise.

The following are a set of mobility features that are offered through HCS:

- Mobile Connect: Includes Desk Phone Pickup, Remote Destination Pickup, Mid Call Features
- Enterprise Feature Access: Two-stage dialing without an IVR feature

- Mobile Voice Access: Two-stage dialing with an IVR feature
- Single Enterprise Voice mailbox: Unanswered calls made to the user's enterprise number and extended to the user's mobile phone are sent to the enterprise voicemail system rather than mobile carrier's voicemail system
- Clientless Fixed Mobile Convergence (FMC) Integration to mobile networks

Mobile Connect

The Mobile Connect feature allows an incoming call to an enterprise user to be offered to the user's IP desk phone and up to ten configurable remote destinations. Typically, a user's remote destination is their mobile or cellular telephone. After the call is offered to both the desktop and remote destination phone, the user can answer any of the phones. When the user answers the call on one of the remote destination phones, or on the IP desk phone, the user has the option to hand off or pick up the call on the other phone.

Mobile Connect supports the following scenarios:

- **Desk Phone Pickup:** When a call to the enterprise number has been made by or answered at the desk phone, the user can switch or move the active call to the remote destination.
- **Remote Destination Pickup:** When a call to the enterprise number has been made by or answered at the remote destination, the user can switch or move the active call to the desk phone.

Mobile Connect Mid-Call Features

When a user answers a Mobile Connect call at the remote destination device, the user can invoke mid-call features such as hold, resume, transfer, conference, directed call park, and session handoff by sending DTMF digits from the remote destination phone to Unified Communications Manager through the PSTN.

When the mid-call feature hold, transfer, conference, or directed call park is invoked, MoH is forwarded from Unified Communications Manager to the held party. In-progress calls can be transferred to another phone or directed call park number, or additional phones can be conferenced using enterprise conference resources.

The session handoff mid-call feature enables movement of the active call to the desk phone, but the call rings in to the desk phone, rather than using hold/resume. With the session handoff mid-call feature, call audio is maintained between the remote destination and the far-end until the call is answered at the desk phone.

Mid-call features are invoked at the remote destination phone by a series of DTMF digits forwarded to Unified Communications Manager. After these digit sequences are received by Unified Communications Manager, they are matched to the configured Enterprise Feature Access Codes for hold, exclusive hold, resume, transfer, and conference Unified Communications Manager, and the appropriate function is performed.

Mid-call features can be invoked on smartphones and manually. The following tables show the key sequences for smartphones and manual invocation.

Media resource allocation for mid-call features, such as hold and conference, is determined by the remote destination profile (RDP) configuration. The media resource group list (MRGL), of the device pool configured for the RDP, is used to allocate a conference bridge for the conferencing mid-call feature. The User Hold Audio Source and Network Hold MoH Audio Source settings of the RDP, in combination with the media resource group list (MRGL) of the device pool, is used to determine the appropriate MoH stream that is sent to a held device.

Table 1: Smartphone Key Sequences

Mid-call feature	Enterprise feature access code (default)	Smartphone feature name	Smartphone key sequence	Smartphone behaviour
Directed call park	—	Enterprise directed call park	<ol style="list-style-type: none"> 1. Press Enterprise Directed Call Park soft key. 2. Enter <Directed_Call_Park_Number>. <p>To retrieve a parked call, the user must use Mobile Voice Access or Enterprise Feature Access Two-Stage Dialing to place a call to the directed call park number. When entering the directed call park number to be dialed, it must be prefixed with the appropriate call park retrieval prefix.</p>	<p>Smartphone sends *82.</p> <p>Then the smartphone automatically does the following when the directed call park number is entered:</p> <ol style="list-style-type: none"> 1. Makes a new call to preconfigured Enterprise Feature Access DID. 2. Sends a preconfigured PIN number when Enterprise Feature Access answers it, followed by *84, followed by direct call park number, followed by *84.
Conference	*85	Enterprise Conference	<ol style="list-style-type: none"> 1. Press Enterprise Conference soft key. 2. Enter <Conference_Target/DN>. 3. When conference target answers, press Enterprise Conference soft key. 	<p>Smartphone sends *82.</p> <p>Then the smartphone automatically does the following when the conference target DN is entered:</p> <ol style="list-style-type: none"> 1. Makes a new call to preconfigured Enterprise Feature Access DID. 2. Sends a preconfigured PIN number when Enterprise Feature Access answers it, followed by *85, followed by conference target/DN.
Session handoff	#74	Enterprise session handoff		<p>With the mid-call session handoff feature, MoH is not forwarded to the far-end because the far-end is never placed on hold.</p> <p>Instead, the original audio path is maintained until the mobile user answers the handoff call at the desk phone.</p> <p>Once the call is answered, the call legs are shuffled at the enterprise gateway and the audio path is maintained.</p>

Table 2: Manual Key Sequences

Mid-call feature	Enterprise feature access code (default)	Manual key sequence
Hold	*81	Enter *81

Mid-call feature	Enterprise feature access code (default)	Manual key sequence
Exclusive Hold	*82	Enter *82
Resume	*83	Enter *83
Transfer	*84	<ol style="list-style-type: none"> 1. Enter *82 (Exclusive Hold). 2. Make a new call to Enterprise Feature Access Code. 3. When connected, enter <PIN_number> # *84# <Transfer_Target/DN>#. 4. When answered by transfer target (for consultative transfer) or upon ringback (for early attended transfer), enter *84.
Directed Call Park	—	<ol style="list-style-type: none"> 1. Enter *82 (Exclusive Hold). 2. Make a new call to Enterprise Feature Access DID. 3. When connected, enter <PIN_number> # *84# <Directed_Call_Park_Number>#. <p>To retrieve a parked call, the user must use Mobile Voice Access or Enterprise Feature Access Two-Stage Dialing to place a call to the directed call park number to be dialed that must be prefixed with the appropriate call park retrieval prefix.</p>
Conference	*85	<ol style="list-style-type: none"> 1. Enter *82 (Exclusive Hold). 2. Make a new call to Enterprise Feature Access Code. 3. When connected, enter <PIN_number> # *85# <Conference_Target/DN>#. 4. When the conference target answers, enter *85.
Session handoff	*74	<ol style="list-style-type: none"> 1. Enter *74. 2. Answer at the desk phone when it rings or the light flashes.

Enterprise Feature Access

Enterprise Feature Access includes the mid-call features, and also adds two-stage dialing, providing mobile users with the ability to place calls from their mobile phone as if they were calling from their enterprise IP desk phone. No IVR prompts are required. This feature also provides the ability to mask a user's mobile phone number when sending outbound caller ID. For example, the user's enterprise number is sent as caller ID to ensure that returned calls to the user are made to the enterprise number that result in enterprise call anchoring.

The system-configured Enterprise Feature Access DID is answered by Unified Communications Manager. The user then uses the phone key pad or smartphone soft keys to input authentication and the number to be dialed. These inputs are received without prompts.

An administrator must configure a number of service parameters for this feature that are available in the *Administration Guide for Cisco Unified Communications Manager*, available at <http://www.cisco.com/c/en/us/support/unified-communications/unified-communications-manager-callmanager/products-maintenance-guides-list.html>.

Mobile Voice Access Enterprise

Mobile Voice Access Enterprise is the same as Enterprise Feature Access, except it relies on the VoiceXML gateway for IVR prompts. The IVR platform can be an ISR at the customer premises or at the data center.

Mobile Voicemail Avoidance

The Mobile Voicemail Avoidance feature provides a single voice mailbox for all enterprise business calls. This feature prevents a user from having to check multiple mailboxes (enterprise, cellular, home) for calls to their enterprise phone number that are unanswered. This feature provides two methods for sending all enterprise voicemail to a single mailbox:

- **Timer Control method**—(Default) With this method the system relies on a set of timers (one for each remote destination) in conjunction with system call-forward timers to ensure that, when a call is forwarded to a voicemail system on ring-no-answer, the enterprise voicemail system receives the call. Perform one of the tasks in the table below to achieve this behavior.
- **User Control method**— With this method the system relies on a DTMF confirmation tone from the remote destination when the call is answered to determine if the call was received by the user or a nonenterprise voicemail system. If a DTMF tone is received by the system, then the system recognizes that the user answered the call and pressed a key to generate the DTMF tone. However, if the DTMF tone is not received by the system, the system assumes the call leg was answered by a nonenterprise voicemail system and it disconnects the call leg.



Note

The User Control method depends on successful relay of the DTMF tone from the remote destination on the mobile voice network or PSTN to Cisco Unified Communications Manager. The DTMF tone must be sent out-of-band to Unified Communications Manager. If DTMF relay is not properly configured on the network and system, DTMF is not received and all call legs to remote destinations relying on the user control method are disconnected. The system administrator should ensure proper DTMF interoperability and relay across the enterprise telephony network prior to enabling the user control method. If DTMF cannot be effectively relayed from the PSTN to Unified Communications Manager, the Timer Control method should be used instead.

Table 3: Single Enterprise Voice Mailbox Tasks

Task	Description
Ensure the forward-no-answer time is shorter at the desk phone than at the remote destination phones	Make sure that the global Forward No Answer Timer field in Unified Communications Manager or the No Answer Ring Duration field under the individual phone line is configured with a value that is less than the amount of time a remote destination phone rings before forwarding to the remote destination voice mailbox. In addition, you can use the Delay Before Ringing Timer parameter under the Remote Destination configuration page to delay the ringing of the remote destination phone in order to further lengthen the amount of time that must pass before a remote destination phone forwards to its own voice mailbox. However, when adjusting the Delay Before Ringing Timer parameter, take care to ensure that the global Unified Communications Manager Forward No Answer Timer (or the line-level No Answer Ring Duration field) is set sufficiently high enough so that the mobility user has time to answer the call on the remote destination phone. You can set the Delay Before Ringing Timer parameter for each remote destination; it is set to 4000 milliseconds by default.
Ensure that the remote destination phone stops ringing before it is forwarded to its own voice mailbox	Set the Answer Too Late Timer parameter under the Remote Destination configuration page to a value that is less than the amount of time that a remote destination phone rings before forwarding to its voice mailbox. This ensures that the remote destination phone stops ringing before the call can be forwarded to its own voice mailbox. You can set the Answer Too Late Timer parameter for each remote destination; it is set to 19,000 milliseconds by default

Clientless FMC Integration with NNI or SS7

Mobile service providers can provide an enhanced FMC experience to the end users by force routing all calls from/to MSISDN through Unified Communications Manager and using Cisco Unity Connections as a single Unified Communications Manager platform.

Figure 9: Clientless FMC Integration

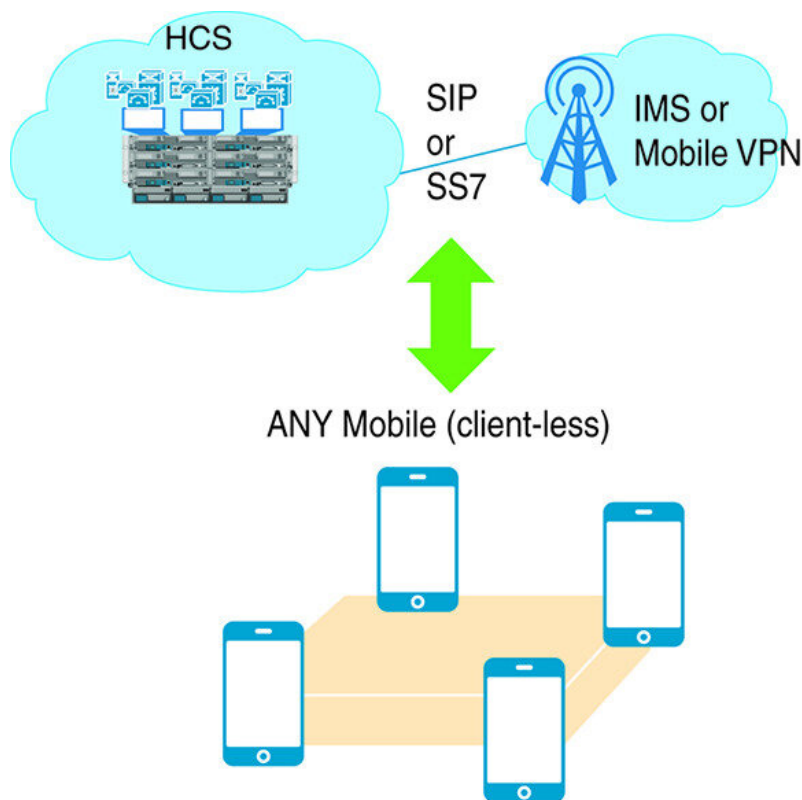

Users can extend the following business features to any mobile device and provide value proposition to MSP by reducing churn and sticky services:

- Enterprise dial plan and calling policy without special client: Same dialing policy, call barring as your desk (including ext dialing).
- Enterprise Caller-ID: Replace mobile number with enterprise caller ID.
- Single Number Reach through both Fixed or Mobile DN: Simultaneous ring for all shared-devices regardless of identity.
- Seamless handoff between devices: Seamless transition of active call between mobile and desk, or soft phone.
- True Single Business Voicemail: Single voice mailbox across multiple phone numbers.
- Native Message Waiting Indicator: MWI for business voicemail.
- DTMF-based Mid-Call features: Music on hold, conference, transfer, call park, session handoff, and call move are invoked through DTMF star codes.

The following call flow shows forced calls through Cisco HCS.

Figure 10: Clientless FMC Integration - Forced Calls

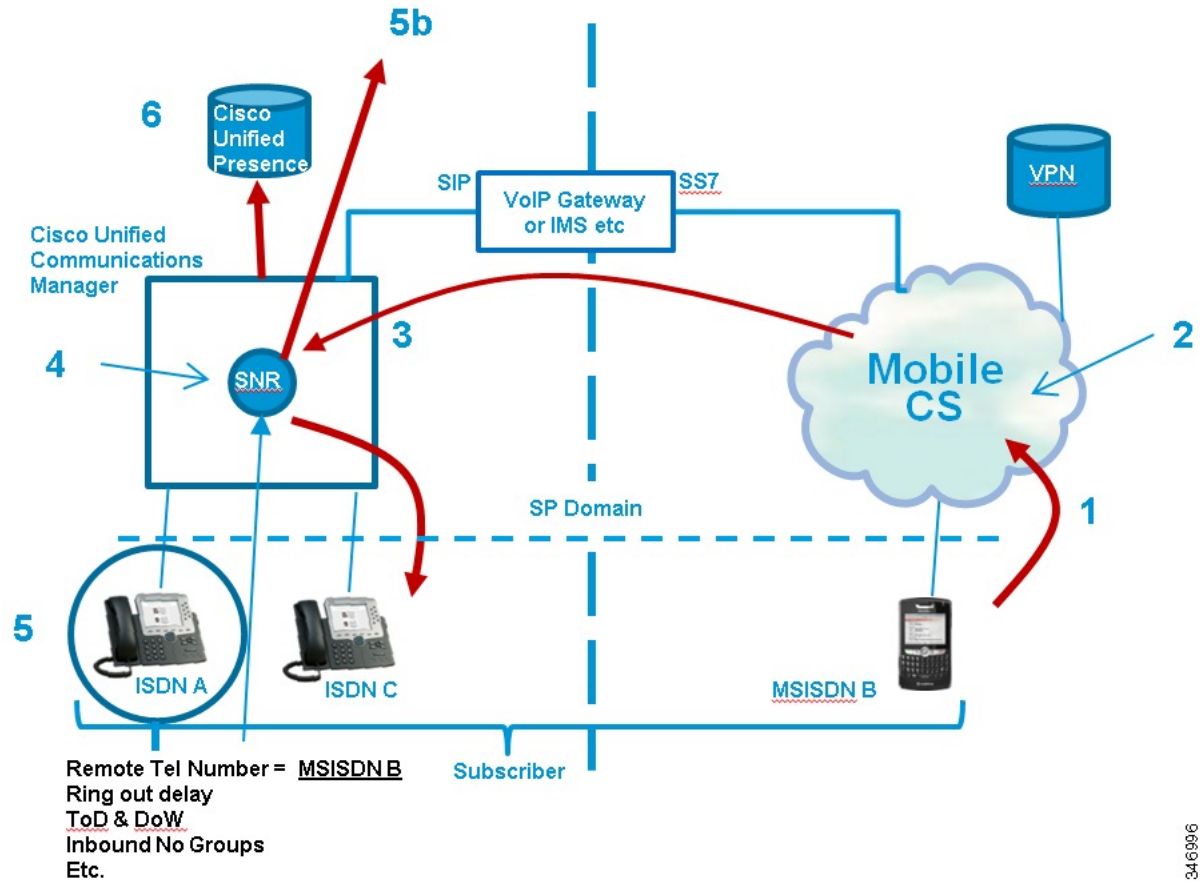

Call flow description for the preceding figure:

1. On-net (short code) or E.164 number is dialed on mobile.
2. CS domain "VPN" IN application force routes all calls through Cisco HCS platform.
3. Call is initiated to any destination CLI : MSISDN B.
4. Unified Communications Manager matches the inbound call to the remote destination associated with ISDN A and routes the call as if it originated from ISDN A.
5. Call is initiated to IP Phone or Communicator Associated with ISDN C CLI= ISDN A.

With the call flow shown in the preceding figure, all of the dialing experience is the same as the enterprise office location. All calling policies/restrictions apply to both fixed and mobile originations. Fixed credentials are presented for off-net calls rather than mobile. However, this feature does rely on the MSP to provide the IN VPN application to trigger the forced routing to Cisco HCS platform.

Figure 11: Mobile Terminated Calls Forced through Cisco HCS

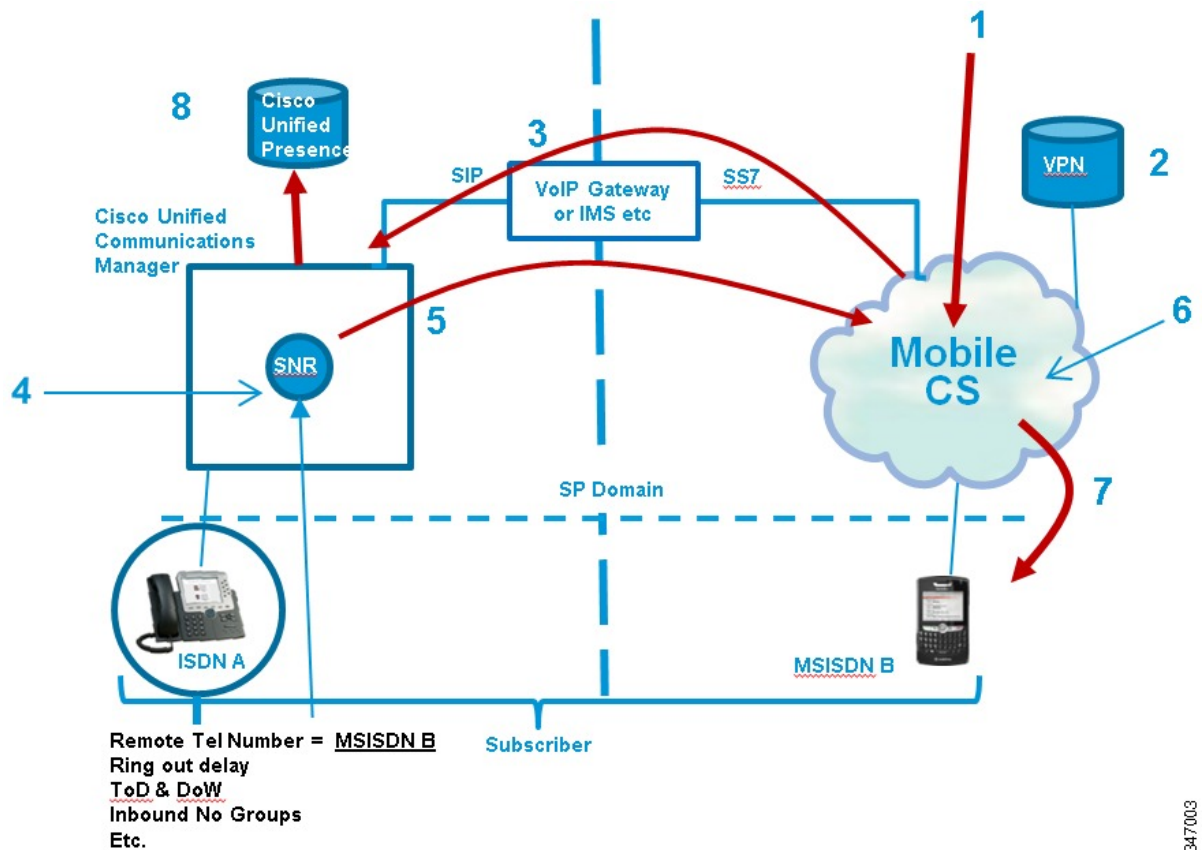

Call flow description for the preceding figure:

1. Call is inbound for MSISDN B.
2. CS domain “VPN” IN application force routes all calls through Cisco HCS platform.
3. Call is routed to Cisco HCS domain.
4. Unified Communications Manager matches the inbound call to the remote destination associated with ISDN A and routes the call as per normal routing.
5. Call is initiated to MSISDN B with a prefix to prevent circular routing.
6. CS domain removes the prefix and routes the call to the mobile.
7. MSISDN B is alerted.

Clientless FMC Integration with IMS

The IP Multimedia Subsystem (IMS) Application Server (AS) is based on the IMS Service Control (ISC) interface (3GPP specification TS 24.229 v 9). However, in the Cisco HCS solution, the Session Border Controller (SBC) is included between IMS and Unified Communications Manager acting as Application Server. The SBC supports the media anchoring, DTMF conversion, and some SIP header manipulations.

ISC interface is defined as call processing control interface between S-CSCF and application server. This interface runs SIP normal protocol as defined by RFC 3261, with additional enhancement to signify "origination" or "termination" call leg toward the application server.

Mobile Clients and Devices

Mobile devices, including dual-mode smartphones and the clients that run on them, afford an enterprise the ability to provide customized voice, video, and data services to users while inside the enterprise and to leverage the mobile carrier network as an alternate connection method for general voice and data services.

Other services and applications you can leverage through Cisco mobile clients and services include enterprise directory, enterprise voicemail, and XMPP-based enterprise IM (instant messaging) and presence. Further, you can deploy these clients and devices in conjunction with Cisco Unified Mobility so that users can leverage additional features and functions with their mobile device, such as Mobile Connect, and single enterprise voice mailbox.

Cisco Jabber

Cisco Jabber is a set of mobile clients for Android and Apple iOS mobile devices including iPhone and iPad that provide the ability to make voice and video calls over IP on the enterprise WLAN network or over the mobile data network. Cisco Jabber also provides the ability to access the corporate directory and enterprise voicemail services, and XMPP-based enterprise IM and Presence services.

The set of mobile clients for Android and Apple iOS include the following:

- Cisco Jabber for Android and iPhone
- Cisco Jabber for iPad

IMS Clients

To provide HCS FMC services, Unified Communications Manager defines generic mobile phones. They include "IMS Mobile(Basic)" and "Carrier Integrated Mobile".

Cisco Proximity for Mobile Voice

Cisco Proximity for Mobile Voice allows users of Apple iOS and Android smartphones and tablets to wirelessly connect to Cisco IP Phones and endpoints through a Bluetooth pairing. For more information about Intelligent Proximity for Mobile Voice, refer to <http://www.cisco.com/go/proximity> and the product documentation for the endpoints.

This feature

- **Sends audio of a cellular-terminated active call to the specified Cisco endpoint speaker or handset for superior audio quality.** Audio play-out of the cellular-terminated call can be moved back and forth between the DX, 8851, or 8861 and the mobile device. Because the Bluetooth-paired mobile device appears on the endpoints as another line, cellular calls on the Bluetooth-paired mobile device can also be initiated using the DX or 8800 IP endpoint.
- **Imports mobile device contacts and share call history** with the DX Series, 8851 or 8861 endpoints using the Bluetooth Phone Book Access Profile (PBAP), to simplify the call management process. You can also view signal strength and battery level of the mobile device on the Cisco IP Phone.

**Note**

- A maximum of 1500 contacts can be imported and displayed on Cisco IP Phones 8851 and 8861. Each contact item can have a maximum of five numbers with a maximum of 30 characters for each number. The allowed contact name is a maximum of 60 characters.
- When an Android phone is connected, the user sees an alert pop-up asking whether Phone Book Access is allowed. The number must select **Allowed** within 30 seconds in order to import the Android phone book to Cisco IP Phones 8851 and 8861.

Because Cisco Proximity for Mobile Voice relies on Bluetooth pairing, there is no requirement to run an application or client on the mobile device. All communication and interaction occurs over the standard-based Bluetooth interfaces.

Cisco Hosted Collaboration Mediation Fulfillment Impact

- HCM-F does not support C-series servers.
- The C-series servers cannot be configured in HCM-F, manually or through automatic sync.
- The ESXi hosts associated with the C-series servers are synced into SDR from vCenter.
- Virtual machines running on the C-series servers are synced from vCenter.
- Because the hardware associated with the C-series does not appear in SDR, service assurance is not able to do some service impact analysis and root cause analysis based on events from the C-series server. The reason is because SDR does not show which ESXi Host is associated with each C-series server.

Cisco Collaboration Clients and Applications

Cisco Collaboration Clients and Applications provide an integrated user experience and extend the capabilities and operations of the Cisco Unified Communications System. These clients and applications enable collaboration both inside and outside the company boundaries by bringing together, in a single easy to use collaboration client, applications such as online meetings, presence notification, instant messaging, audio, video, voicemail, and many more.

Several Cisco collaboration clients and applications are available. Third-party XMPP clients and applications are also supported. Cisco clients use the Cisco Unified Client Services Framework to integrate with underlying Unified Communication services through a common set of interfaces. In general, each client provides support for a specific operating system or device type. Use this document to determine which collaboration clients and applications are best suited for your deployment. The client-specific sections of this document also provide relevant deployment considerations, planning, and design guidance around integration into the Cisco Unified Communications System.

The Cisco Unified Communications System supports the following collaboration clients and applications:

- Cisco Jabber for Windows and Mac

The Cisco Jabber client streamlines communications and enhances productivity by unifying presence, instant messaging, video, voice, voice messaging, screen sharing, and conferencing capabilities securely into one client on your desktop. Cisco Jabber for Mac and Cisco Jabber for Windows deliver highly secure, clear, and reliable communications. They offer flexible deployment models, are built on open standards, and integrate with commonly used desktop applications. With the Cisco Jabber client, you can communicate and collaborate effectively from anywhere you have an Internet connection

- Cisco Webex

Whether on the go, at a desk, or together in a meeting room, Cisco Webex helps speed up projects, build better relationships, and solve business challenges. It's got all the team collaboration tools you need to keep work moving forward and connects with the other tools you use to simplify life.

- Third-party XMPP clients and applications

Cisco Unified Communications Manager IM and Presence Service, with support for SIP/SIMPLE and Extensible Messaging and Presence Protocol (XMPP), provides support of third-party clients and applications to communicate presence and instant messaging updates between multiple clients. Third-party XMPP clients, MomentIM, Adium, Ignite Realtime Spark, Pidgin, and others, allow for enhanced interoperability across various desktop operating systems. In addition, web-based applications can obtain presence updates, instant messaging, and roster updates using the HTTP interface with SOAP, REST, or BOSH (based on the Cisco AJAX XMPP Library API).

Endpoints - Conference

Be sure to consider requirements for conference endpoints as part of your Cisco HCS deployment:

- The Cisco Telepresence MX Series turns any conference room into a video collaboration hub by connecting teams face to face at a moment's notice. MX Series features the MX700 and MX800 systems for medium and large rooms, and gives you flexibility to deploy and scale video depending on the needs of your business.

For more information, see the Cisco Telepresence MX Series documentation: <https://www.cisco.com/c/en/us/support/collaboration-endpoints/telepresence-mx-series/tsd-products-support-series-home.html>

- The Cisco Webex DX Series offers all-in-one desktop collaboration, clearing desktop clutter while adding high-quality video conferencing. Enjoy all-in-one HD video and voice, with unified communications features that can replace your IP phone. With the Cisco Webex Room OS, you can whiteboard and annotate shared content with the touchscreen.

For more information, see the Cisco Webex DX Series documentation: <https://www.cisco.com/c/en/us/support/collaboration-endpoints/desktop-collaboration-experience-dx600-series/tsd-products-support-series-home.html>

Directory

LDAP Integration

Any access to a corporate directory for user information requires LDAP synchronization with Unified Communications Manager. However, if a deployment includes both an LDAP server and Unified

Communications Manager that does not have LDAP synchronization enabled, then the administrator should ensure consistent configuration across Unified Communications Manager and LDAP when configuring user directory number associations.

Cisco Unified CM User Data Service (UDS)

UDS provides clients with a contact search service on Cisco Unified Communications Manager. You can synchronize contact data into the Cisco Unified CM User database from Microsoft Active Directory or other LDAP directory sources. Clients can then automatically retrieve that contact data directly from Unified CM using the UDS REST interface.

LDAP Directory

You can configure a corporate LDAP directory to satisfy a number of different requirements, including the following:

- User provisioning: you can provision users automatically from the LDAP directory into the Cisco Unified Communications Manager database using directory integration. Cisco Unified CM synchronizes with the LDAP directory content so that you avoid having to add, remove, or modify user information manually each time a change occurs in the LDAP directory.
- User authentication: you can authenticate users using the LDAP directory credentials. Cisco IM and Presence synchronizes all the user information from Cisco Unified Communications Manager to provide authentication for client users.
- User lookup: you can enable LDAP directory lookups to allow Cisco clients or third-party XMPP clients to search for contacts in the LDAP directory.

Cisco Webex Directory Integration

Cisco Webex Directory Integration is achieved through the Cisco Webex Administration Tool. WebEx imports a comma-separated value (CSV) file of your enterprise directory information into its Cisco Webex Messenger service. For more information, refer to the documentation at: <http://www.webex.com/webexconnect/orgadmin/help/index.htm?toc.htm?17444.htm>.

Client Services Framework Cache

The Client Services Framework maintains a local cache of contact information derived from previous directory queries and contacts already listed, as well as the local address book or contact list. If a contact for a call already exists in the cache, the Client Services Framework does not search the directory. If a contact does not exist in the cache, the Client Services Framework performs a directory search.

Directory Search

When a contact cannot be found in the local Client Services Framework cache or contact list, a search for contacts can be made. The Cisco Webex Messenger user can utilize a predictive search whereby the cache, contact list, and local Outlook contact list are queried as the contact name is being entered. If no matches are found, the search continues to query the corporate directory (Cisco Webex Messenger database).

Client Services Framework – Dial Plan Considerations

Dial plan and number normalization considerations must be taken into account when deploying the Client Services Framework as part of any Unified Communications endpoint strategy. The Client Services Framework, as part of a Unified Communications collaboration client, will typically use the directory for searching, resolving, and adding contacts. The number that is associated with those contacts must be in a form that the client can recognize, resolve, and dial.

Deployments may vary, depending on the configuration of the directory and Unified CM. In the case where the directory contains E.164 numbering (for example, +18005551212) for business, mobile, and home telephone numbers and Unified CM also contains an E.164 dial plan, the need for additional dial rules is minimized because every lookup, resolution, and dialed event results in an E.164 formatted dial string.

If a deployment of Unified CM has implemented a private dial plan (for example, 5551212), then translation of the E.164 number to a private directory number needs to occur on Unified CM. Outbound calls can be translated by Unified CM translation patterns that allow the number being dialed (for example, +18005551212) to be presented to the endpoint as the private number (5551212 in this example). Inbound calls can be translated by means of directory lookup rules. This allows an incoming number of 5551212 to be presented for reverse number lookup caller identification as +18005551212.

Private numbering plan deployments may arise, where the dial plan used for your company and the telephone number information stored in the LDAP directory may require the configuration of translation patterns and directory lookup rules in Cisco Unified Communications Manager to manage number format differences. Directory lookup rules define how to reformat the inbound call ID to be used as a directory lookup key. Translation patterns define how to transform a phone number retrieved from the LDAP directory for outbound dialing.

Translation Patterns

Translation patterns are used by Unified CM to manipulate the dialed digits before a call is routed, and they are strictly handled by Unified CM. Translation patterns are the recommended method for manipulating dialed numbers.

Application Dialing Rules

Application dialing rules can be used as an alternative to translation patterns to manipulate numbers that are dialed. Application dialing rules can automatically strip numbers from, or add numbers to, phone numbers that the user dials. Application dial rules are configured in Unified CM and are downloaded through TFTP to the client from Unified CM. Translation patterns are the recommended method for manipulating dialed numbers.

Directory Lookup Rules

Directory lookup rules transform caller identification numbers into numbers that can be looked up in the directory. A directory lookup rule specifies which numbers to transform based on the initial digits and the length of the number. Directory lookup rules are configured in Unified CM and are downloaded through TFTP to the client from Unified CM.

Client Transformation

Before a call is placed through contact information, the client application removes everything from the phone number to be dialed, except for letters and digits. The application transforms the letters to digits and applies the dialing rules. The letter-to-digit mapping is locale-specific and corresponds to the letters found on a standard telephone keypad for that locale. For example, for a US English locale, 1-800-4UCSRND transforms to 18004827763. Users cannot view or modify the client transformed numbers before the application places the call.

Deploying Client Services Framework

Because the Client Services Framework is a fundamental building block for Unified Communications client integration and communication, it is necessary to deploy these devices to a number of users. Cisco recommends using the Bulk Administration Tool for the Client Services Framework deployment. The administrator can create a phone template for device pool, device security profile, and phone buttons, and can create a CSV data file for the mapping of device name to directory number. The administrator can also create a User template to include user groups and CTI, if enabled, as well as a CSV data file to map users to the appropriate controlled device.

Design Considerations for Client Services Framework

Observe the following design considerations when deploying the Cisco Unified Client Services Framework:

- The administrator must determine how to install, deploy, and configure the Unified Client Services Framework in their organization. Cisco recommends using a well known installation package such as Altiris to install the application
- The userid and password configuration of the Cisco Unified Client Services Framework user must match the userid and password of the user stored in the LDAP server to allow for proper integration of the Unified Communications and back-end directory components.
- The directory number configuration on Cisco Unified CM and the telephoneNumber attribute in LDAP should be configured with a full E.164 number. A private enterprise dial plan can be used, but it might involve the need to use translation patterns or application dialing rules and directory lookup rules.
- The use of deskphone mode for control of a Cisco Unified IP Phone uses CTI; therefore, when sizing a Unified CM deployment, you must also account for other applications that require CTI usage.
- For firewall and security considerations, the port usage required for the Client Services Framework and corresponding applications being integrated can be found in the product release notes for each application.
- To reduce the impact on the amount of traffic (queries and lookups) to the back-end LDAP servers, configure concise LDAP search bases for the Client Services Framework rather than a top-level search base for the entire deployment.

Deployment Models for Jabber Clients

Cisco Jabber for Windows and Jabber for Mac clients support the following deployment models:

- On-Premises
- Cloud-Based

- Hybrid (Cloud-Based and On-Premises)

Your choice of deployment will depend primarily upon your product choice for IM and presence and the requirement for additional services such as voice and video, voicemail, and deskphone control. For the latest information on Jabber and its deployment, see the installation and upgrade guides for your release:

<https://www.cisco.com/c/en/us/support/unified-communications/jabber-windows/products-installation-guides-list.html>

Push Notifications

Cisco Hosted Collaboration Solution can leverage push notifications for a variety of purposes, including:

- Apple iOS notifications
- Smart Licensing for Cisco products
- Endpoint activation

Cisco Webex Hybrid Services Architecture Overview

Cisco Webex Hybrid Services link your on-premises equipment with the Cisco Webex. For each hybrid service, when you register your environment to the cloud, a software connector is installed automatically on your equipment. Your connector communicates securely with our service in the cloud. These services complement your existing environment and provide augmented features for your users.

To integrate Cisco Webex Hybrid Services with Cisco HCS, you must consider:

- Network topology and interconnect options
- Customer and Service Provider administrator responsibilities
- Cisco Webex Hybrid Services connector components and existing Cisco HCS components

Cisco HCS integration must also consider configurations, call flows, the Cisco Webex Hybrid Services call model, and bandwidth calculations. For more information, see the *Cisco Webex Hybrid Services Integration Reference Guide*.

Cisco Cloud Collaboration Management

Cisco Cloud Collaboration Management is the web interface to Cisco Webex administration. It allows the administrator to enable users for Cisco Webex and for Hybrid Services. It is also used to register the Expressway-C connector host to the Cisco Webex and to manage connectors directly from the Cisco Webex.

For more information about Cisco Cloud Collaboration Management, see the Cisco Webex administration guides.

