



## Reporting Server

---

- [Reporting Service, on page 1](#)
- [Reporting Architecture, on page 1](#)
- [Cisco Unified Customer Voice Portal Reporting Server Deployment Options and Sizing, on page 3](#)
- [Cisco Unified Customer Voice Portal Reporting Server Installation and Upgrade, on page 3](#)
- [Cisco Unified Customer Voice Portal Reporting Server Setup, on page 3](#)
- [Database Maintenance, on page 4](#)

## Reporting Service

Reporting is an optional component for Cisco Unified Customer Voice Portal (CVP) installation.

Select **Reporting** during the installation process to install the Reporting Server, which is comprised of the reporting service and the reporting database.

The reporting service receives reporting data from the Interactive Voice Response (IVR) service, the Session Initiation Protocol (SIP) service (if used), and the VoiceXML (VXML) server and transforms and writes this data to the Informix reporting database to provide historical reporting in a call center environment.

Reporting data includes summary information about call activity, which assists call center managers in reviewing and managing daily operations. It can also include operational detail data for various IVR applications.

## Reporting Architecture

The following diagram shows the Unified CVP architecture. For clarity, the diagram separates the reporting service and the database.



---

**Note** The connection of the Operations Console to the call server through an OAMP Resource Manager (ORM) is simply indicative, because the ORM is invisible to the end user. An ORM is co-located with each managed Unified CVP component, and the Operations Console is connected to each component.

---

Figure 1: CVP Architecture

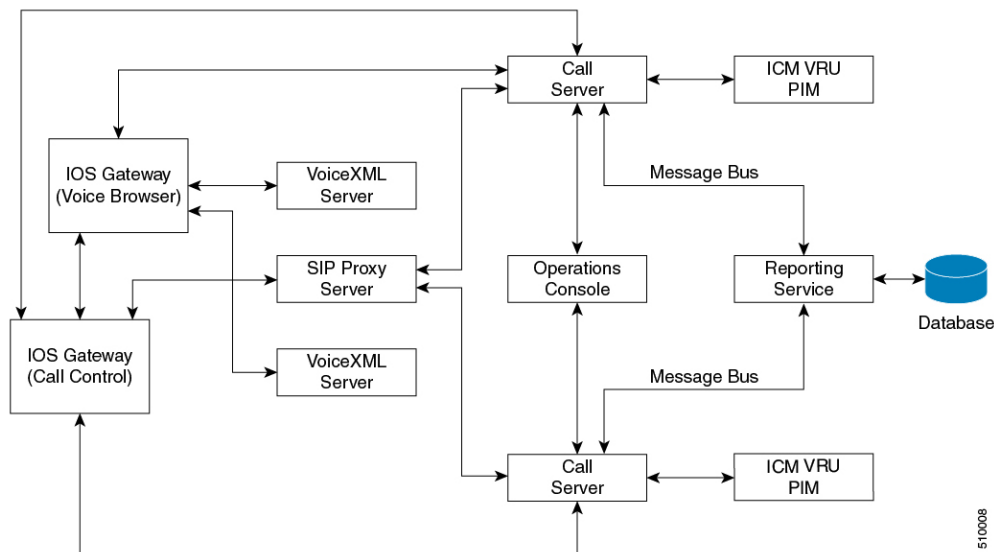

The call server uses a central messaging bus to allow each service to communicate.

The reporting service connects to the message bus through either an in-process plug-in or an out-of-process plug-in, depending on whether the reporting service resides in the same Java Virtual Machine (JVM) with the message bus system.

The service listens to all messages passing through the message bus and captures both call-state change messages sent from Call Server or reporting messages sent from the Reporting Server.

The reporting service then parses those messages, converts them into batches of applicable Structured Query language (SQL) statements, and executes them into an SQL database using the Java Database Connectivity (JDBC) Application provisioning interface (API).

The reporting service can also receive and process Unified CVP messages related to Unified CVP system administrative tasks, such as turning on or off debugging and querying statistics. As the Figure 1 shows, the reporting service can be shared by multiple Call Servers that belong to the same Unified CVP deployment.



**Note** A deployment needs only one reporting server. During temporary database outages, messages are buffered to file and are inserted into the database after the database comes back on line. The amount of time that messages can be buffered depends on the system throughput. See [Failure and Restoration](#).

If your environment uses more than one reporting server, be aware that:

- Each Call Server and each VXML Server can be associated with only one reporting server.
- Reports cannot span multiple Informix databases.

Although Unified CVP does not have a native reporting engine, its installation includes reporting templates designed for use with the Unified Intelligence Center (Unified IC) reporting application. You can import these templates into Unified IC and run them from the Unified IC interface.

# Cisco Unified Customer Voice Portal Reporting Server Deployment Options and Sizing

You can find the Unified CVP reporting solution deployment options, together with related sizing requirements in the *Solution Design Guide for Cisco Unified Contact Center Enterprise* at <https://www.cisco.com/c/en/us/support/customer-collaboration/unified-contact-center-enterprise/products-implementation-design-guides-list.html>.

# Cisco Unified Customer Voice Portal Reporting Server Installation and Upgrade

Explanations and procedures regarding the installation and upgrade of the Unified CVP reporting server are documented in the [Installation and Upgrade Guide for Cisco Unified Customer Voice Portal](#).

Topics in the Installation and Upgrade guide include:

- Installing the reporting component
- Specifying the reporting password
- Excluding the reporting server from anti-virus software port blocking
- Applying a license file to the reporting server
- Changing licensing information for the reporting server
- Upgrading the reporting server
- Adding reporting capability to the VXML Server
- Backing up and purging of the reporting database

# Cisco Unified Customer Voice Portal Reporting Server Setup

You can find explanations and procedures regarding the configuration and maintenance of the Unified CVP Reporting server in the *Administration Guide for Cisco Unified Customer Voice Portal* and in the *Configuration Guide for Cisco Unified Customer Voice Portal*.

Topics in the operations console help and in the Configuration guide include:

- Reporting server statistics
- Adding a reporting server
- Editing a reporting server
- Deleting a reporting server
- Finding a reporting server
- Applying a license to a reporting server

- Configuring a VoiceXML server for reporting (adding and editing)
- Applying inclusive and exclusive VoiceXML filters for reporting
- Transferring a file to multiple devices

## Database Maintenance

Through the Operations Console, Unified CVP provides access to database maintenance and enables you to perform administrative tasks such as backups and purges.

See *Configuration Guide for Cisco Unified Customer Voice Portal* for details on database operations.