



## SIP Call Flows

---

This section describes some basic call flows for the Cisco ATA:

- [Supported SIP Request Methods, page D-1](#)
- [Call Flow Scenarios for Successful Calls, page D-2](#)



**Note**

---

The term *Cisco ATA* refers to both the Cisco ATA 186 and the Cisco ATA 188, unless otherwise stated.

---

## Supported SIP Request Methods

The Cisco ATA supports the following SIP request methods:

- INVITE—Indicates a user or service is being invited to participate in a call session.
- ACK—Confirms that the client has received a final response to an INVITE request.
- BYE—Terminates a call and can be sent by either the caller or the callee.
- CANCEL—Cancels any pending searches but does not terminate a call that has already been accepted.
- REGISTER—Registers the address listed in the To header field with a SIP proxy.
- NOTIFY—Notifies the user of the status of a transfer using REFER. Also used for remote reset.
- OPTIONS

The following types of responses are used by SIP and generated by the Cisco SIP gateway:

- SIP 1xx—Informational responses
- SIP 2xx—Successful responses
- SIP 3xx—Redirection responses
- SIP 4xx—Client Failure responses
- SIP 5xx—Server Failure responses
- SIP 6xx—Global Failure responses

# Call Flow Scenarios for Successful Calls

This section describes call flows for the following scenarios:

- [Cisco ATA-to-SIP Server—Registration without Authentication, page D-2](#)
- [Cisco ATA-to-SIP Server—Registration with Authentication, page D-3](#)
- [Cisco ATA-to-Cisco ATA—Basic SIP to SIP Call without Authentication, page D-6](#)
- [Cisco ATA-to-Cisco ATA—Basic SIP to SIP Call with Authentication, page D-12](#)

Each of the call flows includes a call diagram, action descriptions table, and a sample log file.

## Cisco ATA-to-SIP Server—Registration without Authentication

[Figure D-1](#) illustrates the Cisco ATA registering with the SIP server. Authentication is not required for registration.

The call flow is as follows:

1. Cisco ATA requests registration.
2. Registration is completed.

**Figure D-1 Cisco ATA-to-SIP Server—Registration without Authentication**

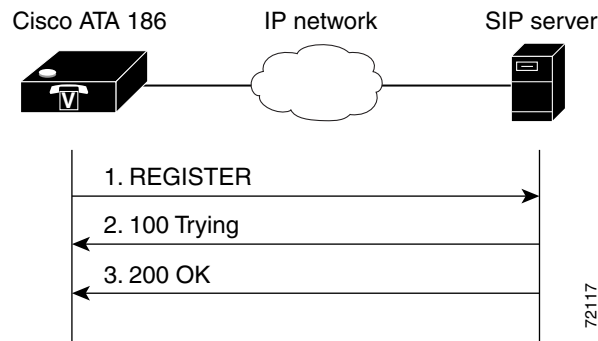

**Table D-1 Action Descriptions**

Step	Action	Description
Step 1	REGISTER—Cisco ATA to SIP server	Cisco ATA sends a REGISTER message to the SIP server to register the address in the To header field.
Step 2	100 Trying—SIP Server to Cisco ATA	SIP server returns a 100 Trying message, indicating that the REGISTER request has been received.
Step 3	200 OK—SIP server to Cisco ATA	SIP server returns a final 200 OK response, confirming that registration is complete.

**Table D-2 Log Listings**

<b>1.</b>	<pre>REGISTER sip:192.168.2.97 SIP/2.0 Via: SIP/2.0/UDP 192.168.2.194 From: &lt;sip:9301@192.168.2.97;user=phone&gt; To: &lt;sip:9301@192.168.2.97;user=phone&gt; Call-ID: 88397253@192.168.2.194 CSeq: 1 REGISTER Contact: &lt;sip:9301@192.168.2.194;user=phone;transport=udp&gt;;expires=3600 User-Agent; Cisco ATA v2.10 ata186 (0705a) Content-Length: 0</pre>
<b>2.</b>	<pre>SIP/2.0 100 Trying Via: SIP/2.0/UDP 192.168.2.194 Call-ID: 88397253@192.168.2.194 From: &lt;sip:9301@192.168.2.97;user=phone&gt; To: &lt;sip:9301@192.168.2.97;user=phone&gt; CSeq: 1 REGISTER Content-Length: 0</pre>
<b>3.</b>	<pre>SIP/2.0 200 OK Via: SIP/2.0/UDP 192.168.2.194 Call-ID: 88397253@192.168.2.194 From: &lt;sip:9301@192.168.2.97;user=phone&gt; To: &lt;sip:9301@192.168.2.97;user=phone&gt; CSeq: 1 REGISTER Contact: &lt;sip:9301@192.168.2.194;user=phone;transport=udp&gt;;expires="Tue, 23 Oct 2001 14:24:57 GMT" Expires: 3600 Content-Length: 0</pre>

## Cisco ATA-to-SIP Server—Registration with Authentication

Figure D-2 illustrates the Cisco ATA registering with the SIP server. Authentication is required for registration.

The call flow is as follows:

1. Cisco ATA requests registration.
2. SIP server requests authentication credential.
3. Authentication is received and registration is completed.

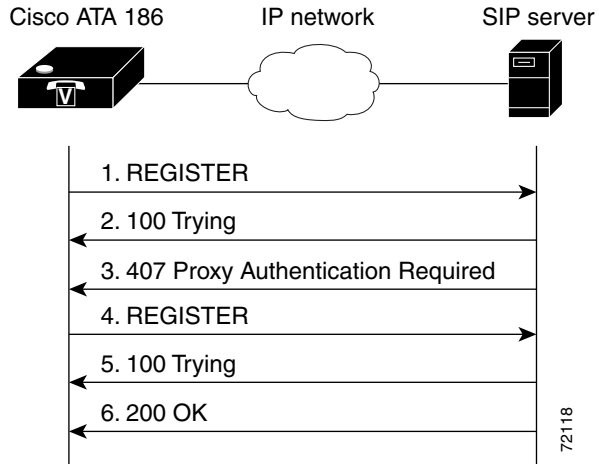
**Figure D-2 Cisco ATA-to-SIP Server—Registration with Authentication****Table D-3 Action Descriptions**

Step	Action	Description
Step 1	REGISTER—Cisco ATA to SIP server	Cisco ATA sends a REGISTER message to the SIP server to register the address in the To header field.
Step 2	100 Trying—SIP server to Cisco ATA	SIP server returns a 100 trying message, indicating that the REGISTER request has been received.
Step 3	407 Proxy authentication required— SIP server to Cisco ATA	SIP server returns a request for authentication.
Step 4	REGISTER—Cisco ATA to SIP server	Cisco ATA attempts to register using its authentication credential.
Step 5	100 Trying—SIP server to Cisco ATA	SIP server returns a 100 trying message, indicating that the new REGISTER request has been received.
Step 6	200 OK—SIP server to Cisco ATA	SIP server returns a final 200 OK response, confirming that the authentication credential has been verified and registration is complete.

Table D-4 Log Listings

1.	<pre>REGISTER sip:192.168.2.81 SIP/2.0 Via: SIP/2.0/UDP 192.168.2.194 From: &lt;sip:9301@192.168.2.81;user=phone&gt; To: &lt;sip:9301@192.168.2.81;user=phone&gt; Call-ID: 311316842@192.168.2.194 CSeq: 1 REGISTER Contact: &lt;sip:9301@192.168.2.194;user=phone;transport=udp&gt;;expires=3600 User-Agent: Cisco ATA v2.10 ata186 (0705a) Content-Length: 0</pre>
2.	<pre>SIP/2.0 100 Trying Via: SIP/2.0/UDP 192.168.2.194 Call-ID: 311316842@192.168.2.194 From: &lt;sip:9301@192.168.2.81;user=phone&gt; To: &lt;sip:9301@192.168.2.81;user=phone&gt; CSeq: 1 REGISTER Content-Length: 0</pre>
3.	<pre>SIP/2.0 407 Proxy Authentication Required Via: SIP/2.0/UDP 192.168.2.194 Call-ID:311316842@192.168.2.194 From: &lt;sip:9301@192.168.2.81;user=phone&gt; To: &lt;sip:9301@192.168.2.81;user=phone&gt; CSeq: 1 REGISTER Proxy-Authenticate: DIGEST realm="CISCO", nonce="3bd5e334" Content-Length: 0</pre>
4.	<pre>REGISTER sip:192.168.2.81 SIP/2.0 Via: SIP/2.0/UDP 192.168.2.194 From: &lt;sip:9301@192.168.2.81;user=phone&gt; To: &lt;sip:9301@192.168.2.81;user=phone&gt; Call-ID: 311316842@192.168.2.194 CSeq: 2 REGISTER Contact: &lt;sip:9301@192.168.2.194;user=phone;transport=udp&gt;;expires=3600 User-Agent: Cisco ATA v2.10 ata186 (0705a) Proxy-Authorization: Digest username="9301", realm="CISCO", nonce="3bd5e334", uri="sip:192.168.2.81", response="87ac0afeb08222af706f9e8b5c566ce2" Content-Length: 0</pre>
5.	<pre>SIP/2.0 100 Trying Via: SIP/2.0/UDP 192.168.2.194 Call-ID: 311316842@192.168.2.194 From: &lt;sip:9301@192.168.2.81;user=phone&gt; To: &lt;sip:9301@192.168.2.81;user=phone&gt; CSeq: 2 REGISTER Content-Length: 0</pre>
6.	<pre>SIP/2.0 200 OK Via: SIP/2.0/UDP 192.168.2.194 Call-ID: 311316842@192.168.2.194 From: &lt;sip:9301@192.168.2.81;user=phone&gt; To: &lt;sip:9301@192.168.2.81;user=phone&gt; CSeq: 2 REGISTER Contact: &lt;sip:9301@192.168.2.194;user=phone;transport=udp&gt;;expires="tue, 23 Oct 2001 22:37:56 GMT" Expires: 3600 Content-Length: 0</pre>

## Cisco ATA-to-Cisco ATA—Basic SIP to SIP Call without Authentication

Figure D-3 illustrates a call from one Cisco ATA to another. Authentication by the SIP server is not required.

The call flow is as follows:

1. Call is established between Cisco ATA A and Cisco ATA B.
2. Call is terminated.

**Figure D-3** Cisco ATA-to-Cisco ATA—Basic SIP to SIP Call without Authentication

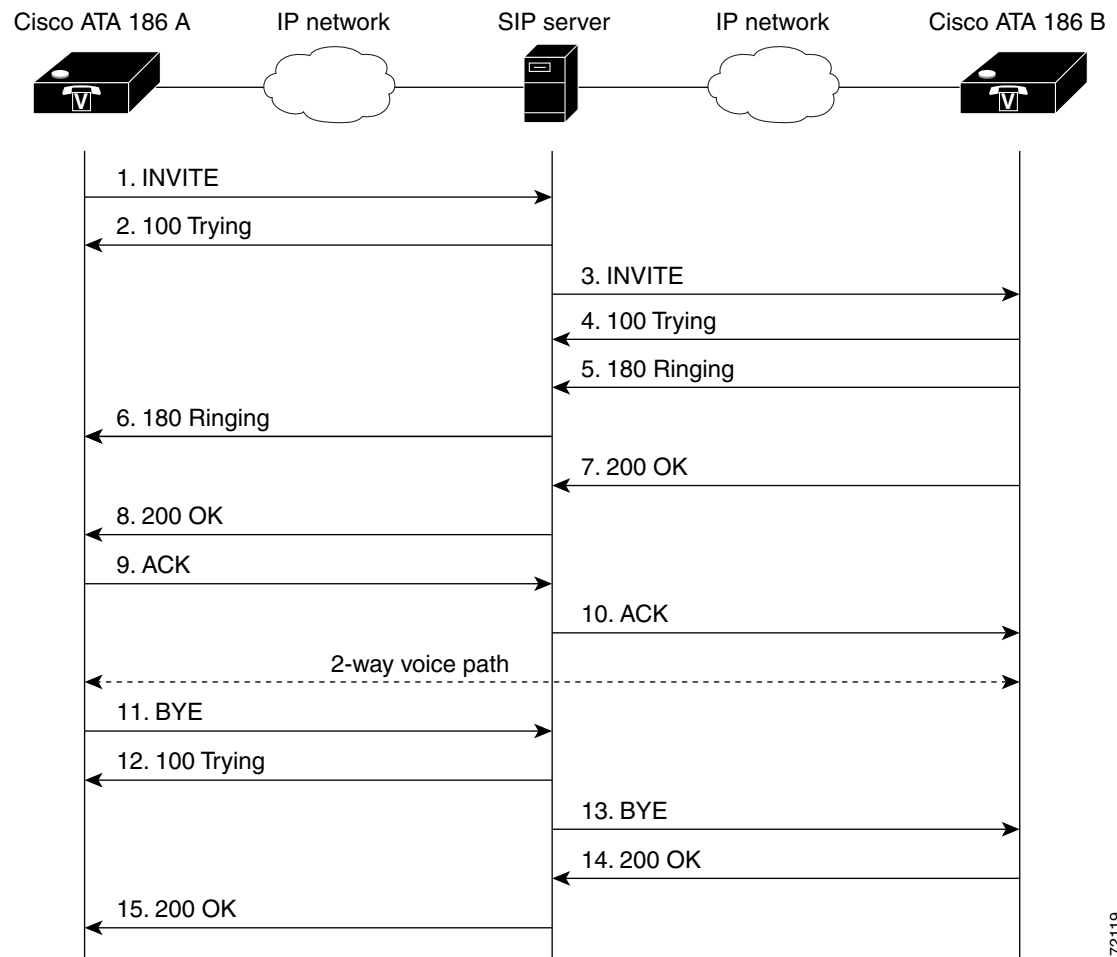

72119

**Table D-5 Action Descriptions**

<b>Step</b>	<b>Action</b>	<b>Description</b>
<b>Step 1</b>	INVITE—Cisco ATA A to SIP server	Cisco ATA A sends a call session INVITE request to the SIP server to pass on to Cisco ATA B.
<b>Step 2</b>	100 Trying—SIP server to Cisco ATA A	SIP server returns a 100 trying message, indicating that the INVITE request has been received.
<b>Step 3</b>	INVITE—SIP server to Cisco ATA B	SIP server sends the call session INVITE request to Cisco ATA B.
<b>Step 4</b>	100 Trying—Cisco ATA B to SIP server	Cisco ATA B returns a 100 trying message indicating that the INVITE request has been received.
<b>Step 5</b>	180 Ringing—Cisco ATA B to SIP server	Cisco ATA B sends a 180 ringing response to the SIP server to pass on to Cisco ATA A.
<b>Step 6</b>	180 Ringing—SIP server to Cisco ATA A	SIP server sends the 180 ringing response to Cisco ATA A.
<b>Step 7</b>	200 OK—Cisco ATA B to SIP server	Cisco ATA B sends a 200 OK message to the SIP server indicating that a connection has been established.
<b>Step 8</b>	200 OK—SIP server to Cisco ATA A	SIP server passes the 200 OK message to Cisco ATA A.
<b>Step 9</b>	ACK—Cisco ATA A to SIP server	Cisco ATA A sends acknowledgement of the 200 OK response to the SIP server to pass on to Cisco ATA B.
<b>Step 10</b>	ACK—SIP server to Cisco ATA B	SIP server passes ACK response to Cisco ATA B.
A two-way voice path is established between Cisco ATA A and Cisco ATA B.		
<b>Step 11</b>	BYE—Cisco ATA A to SIP server	Cisco ATA A terminates the call session and sends a BYE request to the SIP server indicating that Cisco ATA A wants to terminate the call.
<b>Step 12</b>	100 Trying—SIP server to Cisco ATA A	SIP server returns a 100 trying message indicating that the BYE request has been received.
<b>Step 13</b>	BYE—SIP server to Cisco ATA B	SIP server passes the BYE request to Cisco ATA B.
<b>Step 14</b>	200 OK—Cisco ATA B to SIP server	Cisco ATA B sends a 200 OK message to the SIP server indicating that Cisco ATA B has received the BYE request.
<b>Step 15</b>	200 OK—SIP server to Cisco ATA A	SIP server passes the BYE request to Cisco ATA A.

Table D-6 Log Listings

1.	<pre> INVITE sip:9000@192.168.2.97;user=phone SIP/2.0 Via: SIP/2.0/UDP 192.168.3.175 From: &lt;sip:8000@192.168.2.97;user=phone&gt;;tag=2819471139 To: &lt;sip:9000@192.168.2.97;user=phone&gt; Call-ID: 488337201@192.168.3.175 CSeq: 1 INVITE Contact: &lt;sip:8000@192.168.3.175;user=phone;transport=udp&gt; User-Agent: Cisco ATA v2.12 ata186 (0928a) Expires: 300 Content-Length: 253 Content-Type: application/sdp v=0 o=8000 206154 206154 IN IP4 192.168.3.175 s=ATA186 Call c=IN IP4 192.168.3.175 t=0 0 m=audio 10000 RTP/AVP 0 18 8 101 a=rtpmap:0 PCMU/8000/1 a=rtpmap:18 G729/8000/1 a=rtpmap:8 PCMA/8000/1 a=rtpmap:101 telephone-event/8000 a=fmtp:101 0-15 </pre>
2.	<pre> SIP/2.0 100 Trying Via: SIP/2.0/UDP 192.168.3.175 Call-ID: 488337201@192.168.3.175 From: &lt;sip:8000@192.168.2.97;user=phone&gt;;tag=2819471139 To: &lt;sip:9000@192.168.2.97;user=phone&gt; CSeq: 1 INVITE Content-Length: 0 </pre>
3.	<pre> INVITE sip:9000@192.168.2.194;user=phone SIP/2.0 Record-Route: &lt;sip:9000@192.168.2.97:5060;user=phone;maddr=192.168.2.97&gt; Via: SIP/2.0/UDP 192.168.2.97:5060;branch=140fed6e-f61cbd1a-52f223b1-9beb149a-1 Via: SIP/2.0/UDP 192.168.3.175 From: &lt;sip:8000@192.168.2.97;user=phone&gt;;tag=2819471139 To: &lt;sip:9000@192.168.2.97;user=phone&gt; Call-ID: 488337201@192.168.3.175 CSeq: 1 INVITE Contact: &lt;sip:8000@192.168.3.175;user=phone;transport=udp&gt; User-Agent: Cisco ATA v2.12 ata186 (0928a) Expires: 300 Content-Length: 253 Content-Type: application/sdp v=0 o=8000 206154 206154 IN IP4 192.168.3.175 s=ATA186 Call c=IN IP4 192.168.3.175 t=0 0 m=audio 10000 RTP/AVP 0 18 8 101 a=rtpmap:0 PCMU/8000/1 a=rtpmap:18 G729/8000/1 a=rtpmap:8 PCMA/8000/1 a=rtpmap:101 telephone-event/8000 a=fmtp:101 0-15 </pre>



Table D-6 Log Listings (continued)

4.	<pre>SIP/2.0 100 Trying Via: SIP/2.0/UDP 192.168.2.97:5060;branch=140fed6e-f61cbd1a-52f223b1-9beb149a-1 Via: SIP/2.0/UDP 192.168.3.175 Record-Route: &lt;sip:9000@192.168.2.97:5060;user=phone;maddr=192.168.2.97&gt; From: &lt;sip:8000@192.168.2.97;user=phone&gt;;tag=2819471139 To: &lt;sip:9000@192.168.2.97;user=phone&gt;;tag=909616993 Call-ID: 488337201@192.168.3.175 CSeq: 1 INVITE Server: Cisco ATA v2.12 ata186 (0928a) Content-Length: 0</pre>
5.	<pre>SIP/2.0 180 Ringing Via: SIP/2.0/UDP 192.168.2.97:5060;branch=140fed6e-f61cbd1a-52f223b1-9beb149a-1 Via: SIP/2.0/UDP 192.168.3.175 Record-Route: &lt;sip:9000@192.168.2.97:5060;user=phone;maddr=192.168.2.97&gt; From: &lt;sip:8000@192.168.2.97;user=phone&gt;;tag=2819471139 To: &lt;sip:9000@192.168.2.97;user=phone&gt;;tag=909616993 Call-ID: 488337201@192.168.3.175 CSeq: 1 INVITE Server: Cisco ATA v2.12 ata186 (0928a) Content-Length: 0</pre>
6.	<pre>SIP/2.0 180 Ringing Via: SIP/2.0/UDP 192.168.3.175 Record-Route: &lt;sip:9000@192.168.2.97:5060;user=phone;maddr=192.168.2.97&gt; From: &lt;sip:8000@192.168.2.97;user=phone&gt;;tag=2819471139 To: &lt;sip:9000@192.168.2.97;user=phone&gt;;tag=909616993 Call-ID: 488337201@192.168.3.175 CSeq: 1 INVITE Server: Cisco ATA v2.12 ata186 (0928a) Content-Length: 0</pre>
7.	<pre>SIP/2.0 200 OK Via: SIP/2.0/UDP 192.168.2.97:5060;branch=140fed6e-f61cbd1a-52f223b1-9beb149a-1 Via: SIP/2.0/UDP 192.168.3.175 Record-Route: &lt;sip:9000@192.168.2.97:5060;user=phone;maddr=192.168.2.97&gt; From: &lt;sip:8000@192.168.2.97;user=phone&gt;;tag=2819471139 To: &lt;sip:9000@192.168.2.97;user=phone&gt;;tag=909616993 Call-ID: 488337201@192.168.3.175 CSeq: 1 INVITE Contact: &lt;sip:9000@192.168.2.194;user=phone;transport=udp&gt; Server: Cisco ATA v2.12 ata186 (0928a) Content-Length: 199 Content-Type: application/sdp v=0 o=9000 206275 206275 IN IP4 192.168.2.194 s=ATA186 Call c=IN IP4 192.168.2.194 t=0 0 m=audio 10000 RTP/AVP 0 101 a=rtpmap:0 PCMU/8000/1 a=rtpmap:101 telephone-event/8000 a=fmtp:101 0-15</pre>

Table D-6 Log Listings (continued)

8.	<pre>SIP/2.0 200 OK Via: SIP/2.0/UDP 192.168.3.175 Record-Route: &lt;sip:9000@192.168.2.97:5060;user=phone;maddr=192.168.2.97&gt; From: &lt;sip:8000@192.168.2.97;user=phone&gt;;tag=2819471139 To: &lt;sip:9000@192.168.2.97;user=phone;tag=909616993&gt; Call-ID: 488337201@192.168.3.175 CSeq: 1 INVITE Contact: &lt;sip:9000@192.168.2.194;user=phone;transport=udp&gt; Server: Cisco ATA v2.12 ata186 (0928a) Content-Length: 199 Content-Type: application/sdp v=0 o=9000 206275 206275 IN IP4 192.168.2.194 s=ATA186 Call c=IN IP4 192.168.2.194 t=0 0 m=audio 10000 RTP/AVP 0 101 a=rtpmap:0 PCMU/8000/1 a=rtpmap:101 telephone-event/8000 a=fmtp:101 0-15</pre>
9.	<pre>ACK sip:9000@192.168.2.97;user=phone SIP/2.0 Route: &lt;sip:9000@192.168.2.194:5060;user=phone;transport=udp&gt; Via: SIP/2.0/UDP 192.168.3.175 From: &lt;sip:8000@192.168.2.97;user=phone&gt;;tag=2819471139 To: &lt;sip:9000@192.168.2.97;user=phone&gt;;tag=909616993 Call-ID: 488337201@192.168.3.175 CSeq: 1 ACK User-Agent: Cisco ATA v2.12 ata186 (0928a) Content-Length: 0</pre>
10.	<pre>ACK sip:9000@192.168.2.194;user=phone SIP/2.0 Via: SIP/2.0/UDP 192.168.2.97:5060;branch=140fed6e-f61cbd1a-52f223b1-9beb149a- Via: SIP/2.0/UDP 192.168.3.175 From: &lt;sip:8000@192.168.2.97;user=phone&gt;;tag=2819471139 To: &lt;sip:9000@192.168.2.97;user=phone&gt;;tag=909616993 Call-ID: 488337201@192.168.3.175 CSeq: 1 ACK User-Agent: Cisco ATA v2.12 ata186 (0928a) Content-Length: 0</pre>
11.	<pre>BYE sip:9000@192.168.2.97;user=phone SIP/2.0 Route: &lt;sip:9000@192.168.2.194:5060;user=phone;transport=udp&gt; Via: SIP/2.0/UDP 192.168.3.175 From: &lt;sip:8000@192.168.2.97;user=phone&gt;;tag=2819471139 To: &lt;sip:9000@192.168.2.97;user=phone&gt;;tag=909616993 Call-ID: 488337201@192.168.3.175 CSeq: 2 BYE User-Agent: Cisco ATA v2.12 ata186 (0928a) Content-Length: 0</pre>
12.	<pre>SIP/2.0 100 Trying Via: SIP/2.0/UDP 192.168.3.175 Call-ID: 488337201@192.168.3.175 From: &lt;sip:8000@192.168.2.97;user=phone&gt;;tag=2819471139 To: &lt;sip:9000@192.168.2.97;user=phone&gt;;tag=909616993 CSeq: 2 BYE Content-Length: 0</pre>

**Table D-6 Log Listings (continued)**

<b>13.</b>	<pre> BYE sip:9000@192.168.2.194;user=phone SIP/2.0 Via: SIP/2.0/UDP 192.168.2.97:5060;branch=b499b4be-d7995db7-980cd8af-e5ba35f5-1 Via: SIP/2.0/UDP 192.168.3.175 From: &lt;sip:8000@192.168.2.97;user=phone&gt;;tag=2819471139 To: &lt;sip:9000@192.168.2.97;user=phone&gt;;tag=909616993 Call-ID: 488337201@192.168.3.175 CSeq: 2 BYE User-Agent: Cisco ATA v2.12 ata186 (0928a) Content-Length: 0 </pre>
<b>14.</b>	<pre> SIP/2.0 200 OK Via: SIP/2.0/UDP 192.168.2.97:5060;branch=b499b4be-d7995db7-980cd8af-e5ba35f5-1 Via: SIP/2.0/UDP 192.168.3.175 From: &lt;sip:8000@192.168.2.97;user=phone&gt;;tag=2819471139 To: &lt;sip:9000@192.168.2.97;user=phone&gt;;tag=909616993 Call-ID: 488337201@192.168.3.175 CSeq: 2 BYE Server: Cisco ATA v2.12 ata186 (0928a) Content-Length: 0 </pre>
<b>15.</b>	<pre> SIP/2.0 200 OK Via: SIP/2.0/UDP 192.168.3.175 From: &lt;sip:8000@192.168.2.97;user=phone&gt;;tag=2819471139 To: &lt;sip:9000@192.168.2.97;user=phone&gt;;tag=909616993 Call-ID: 488337201@192.168.3.175 CSeq: 2 BYE Server: Cisco ATA v2.12 ata186 (0928a) Content-Length: 0 </pre>

## Cisco ATA-to-Cisco ATA—Basic SIP to SIP Call with Authentication

Figure D-4 illustrates a call from one Cisco ATA to another. Authentication by the SIP server is required.

The call flow is as follows:

1. Authentication is requested for call initiated by Cisco ATA A.
2. Call is established between Cisco ATA A and Cisco ATA B.
3. Call is terminated.

Figure D-4 Cisco ATA-to-Cisco ATA—Basic SIP to SIP Call with Authentication

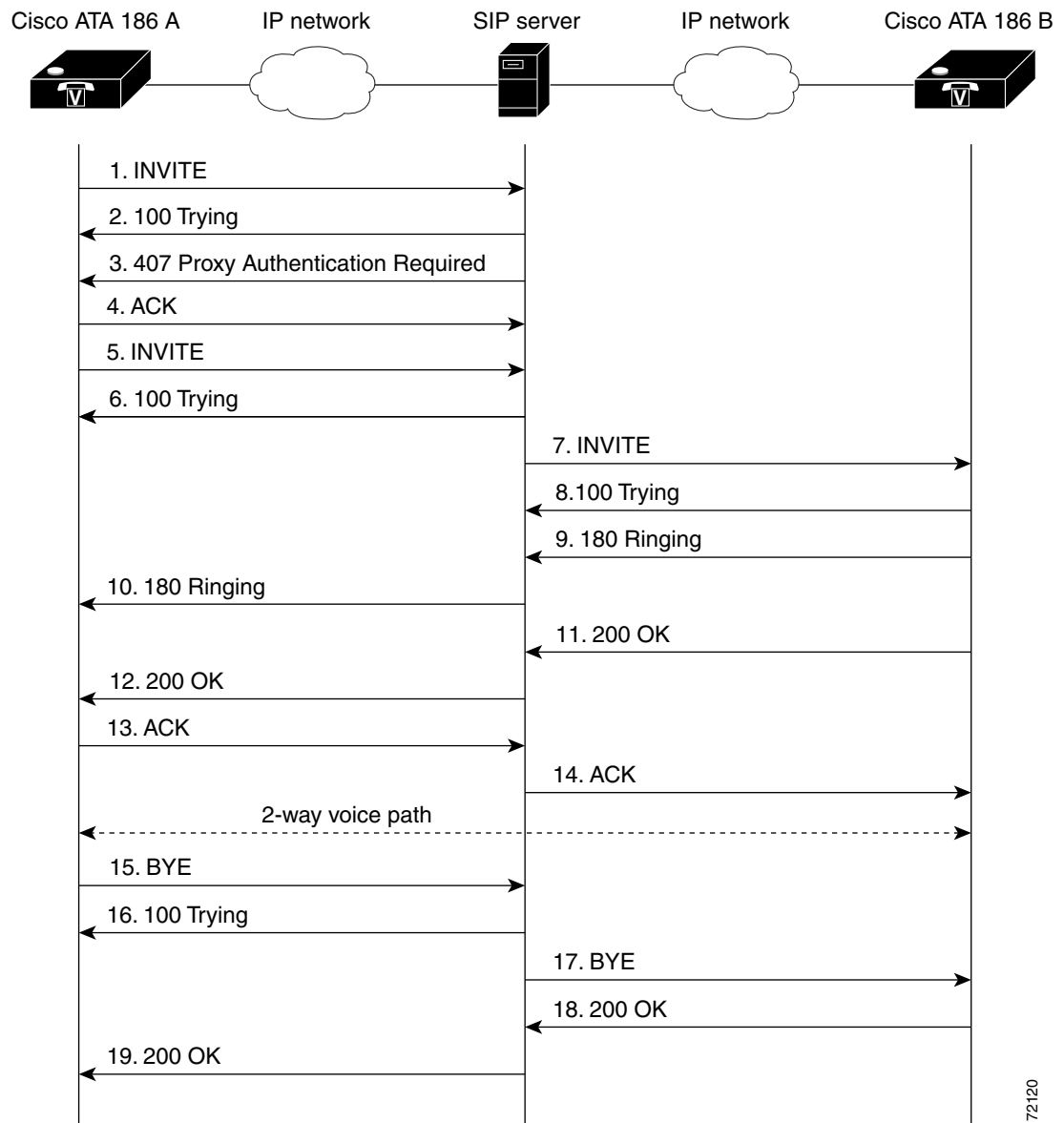

72120

Table D-7 Action Descriptions

Step	Action	Description
Step 1	INVITE—Cisco ATA A to SIP server	Cisco ATA A sends a call session INVITE request to the SIP server to pass on to Cisco ATA B.
Step 2	100 Trying—SIP server to Cisco ATA A	SIP server returns a 100 Trying message, indicating that the INVITE request has been received.
Step 3	407 Proxy Authentication Required—SIP server to Cisco ATA A	SIP server returns a request for authentication to Cisco ATA A.
Step 4	ACK—Cisco ATA A to SIP server	Cisco ATA A acknowledges the request for authentication.
Step 5	INVITE—Cisco ATA A to SIP server	Cisco ATA A sends a call session INVITE request along with authentication credential to the SIP server to pass on to Cisco ATA B.
Step 6	100 Trying—SIP server to Cisco ATA A	SIP server returns a 100 Trying message, indicating that the INVITE request has been received.
Step 7	INVITE—SIP server to Cisco ATA B	SIP server sends the call session INVITE request to Cisco ATA B.
Step 8	100 Trying—Cisco ATA B to SIP server	Cisco ATA B returns a 100 trying message indicating that the INVITE request has been received.
Step 9	180 Ringing—Cisco ATA B to SIP server	Cisco ATA B sends a 180 ringing response to the SIP server to pass on to Cisco ATA A.
Step 10	180 Ringing—SIP server to Cisco ATA A	SIP server sends the 180 ringing response to Cisco ATA A.
Step 11	200 OK—Cisco ATA B to SIP server	Cisco ATA B sends a 200 OK message to the SIP server indicating that a connection has been established.
Step 12	200 OK—SIP server to Cisco ATA A	SIP server passes the 200 OK message to Cisco ATA A.
Step 13	ACK—Cisco ATA A to SIP server	Cisco ATA A sends acknowledgment of the 200 OK response to the SIP server to pass on to Cisco ATA B.
Step 14	ACK—SIP server to Cisco ATA B	SIP server passes ACK response to Cisco ATA B.
A two-way voice path is established between Cisco ATA A and Cisco ATA B.		
Step 15	BYE—Cisco ATA A to SIP server	Cisco ATA A terminates the call session and sends a BYE request to the SIP server indicating that Cisco ATA A wants to terminate the call.
Step 16	100 Trying—SIP server to Cisco ATA A	SIP server returns a 100 trying message indicating that the BYE request has been received.
Step 17	BYE—SIP server to Cisco ATA B	SIP server passes the BYE request to Cisco ATA B.
Step 18	200 OK—Cisco ATA B to SIP server	Cisco ATA 186 B sends a 200 OK message to the SIP server indicating that Cisco ATA 186 B has received the BYE request.
Step 19	200 OK—SIP server to Cisco ATA A	SIP server passes the BYE request to Cisco ATA A.

Table D-8 Log Listings

1.	<pre> INVITE sip:9000@192.168.2.81;user=phone SIP/2.0 Via: SIP/2.0/UDP 192.168.3.175 From: &lt;sip:8000@192.168.2.81;user=phone&gt;;tag=3515135869 To: &lt;sip:9000@192.168.2.81;user=phone&gt; Call-ID: 557188650@192.168.3.175 CSeq: 1 INVITE Contact: &lt;sip:8000@192.168.3.175;user=phone;transport=udp&gt; User-Agent: Cisco ATA v2.12 ata186 (0928a) Expires: 300 Content-Length: 253 Content-Type: application/sdp v=0 o=8000 177731 177731 IN IP4 192.168.3.175 s=ATA186 Call c=IN IP4 192.168.3.175 t=0 0 m=audio 10000 RTP/AVP 0 18 8 101 a=rtpmap:0 PCMU/8000/1 a=rtpmap:18 G729/8000/1 a=rtpmap:8 PCMA/8000/1 a=rtpmap:101 telephone-event/8000 a=fmtp:101 0-15 </pre>
2.	<pre> SIP/2.0 100 Trying Via: SIP/2.0/UDP 192.168.3.175 Call-ID: 557188650@192.168.3.175 From: &lt;sip:8000@192.168.2.81;user=phone&gt;;tag=3515135869 To: &lt;sip:9000@192.168.2.81;user=phone&gt; CSeq: 1 INVITE Content-Length: 0 </pre>
3.	<pre> SIP/2.0 407 Proxy Authentication Required Via: SIP/2.0/UDP 192.168.3.175 Call-ID: 557188650@192.168.3.175 From: &lt;sip:8000@192.168.2.81;user=phone&gt;;tag=3515135869 To:&lt;sip:9000@192.168.2.81;user=phone&gt;;tag=600eaf7-7c3a549a CSeq: 1 INVITE Proxy-Authenticate: DIGEST realm="CISCO", nonce="3bd76584" Content-Length: 0 </pre>
4.	<pre> ACK sip:9000@192.168.2.81:5060 SIP/2.0 Via: SIP/2.0/UDP 192.168.3.175 From: &lt;sip:8000@192.168.2.81;user=phone&gt;;tag=3515135869 To:&lt;sip:9000@192.168.2.81;user=phone&gt;;tag=600eaf7-7c3a549a Call-ID: 557188650@192.168.3.175 CSeq: 1 ACK User-Agent: Cisco ATA v2.12 ata186 (0928a) Content-Length: 0 </pre>

Table D-8 Log Listings (continued)

5.	<pre> INVITE sip:9000@192.168.2.81;user=phone SIP/2.0 Via: SIP/2.0/UDP 192.168.3.175 From: &lt;sip:8000@192.168.2.81;user=phone&gt;;tag=3515135869 To: &lt;sip:9000@192.168.2.81;user=phone&gt; Call-ID: 557188650@192.168.3.175 CSeq: 2 INVITE Contact: &lt;sip:8000@192.168.3.175;user=phone;transport=udp&gt; User-Agent: Cisco ATA v2.12 ata186 (0928a) Proxy-Authorization: Digest username="8000", realm="CISCO", nonce="3bd76584", uri="sip:9000@192.168.2.81", response="6e91de67ad976997ffac76f0398ef224" Expires: 300 Content-Length: 253 Content-Type: application/sdp v=0 o=8000 177738 177738 IN IP4 192.168.3.175 s=ATA186 Call c=IN IP4 192.168.3.175 t=0 0 m=audio 10000 RTP/AVP 0 18 8 101 a=rtpmap:0 PCMU/8000/1 a=rtpmap:18 G729/8000/1 a=rtpmap:8 PCMA/8000/1 a=rtpmap:101 telephone-event/8000 a=fmtp:101 0-15 </pre>
6.	<pre> SIP/2.0 100 Trying Via: SIP/2.0/UDP 192.168.3.175 Call-ID: 557188650@192.168.3.175 From: &lt;sip:8000@192.168.2.81;user=phone&gt;;tag=3515135869 To: &lt;sip:9000@192.168.2.81;user=phone&gt; CSeq: 2 INVITE Content-Length: 0 </pre>
7.	<pre> INVITE sip:9000@192.168.2.194;user=phone SIP/2.0 Record-Route: &lt;sip:9000@192.168.2.81:5060;user=phone;maddr=192.168.2.81 Via: SIP/2.0/UDP 192.168.2.81:5060;branch=c0b3510a-819f9d1a-ea43c345-9604747f-1 Via: SIP/2.0/UDP 192.168.3.175 From: &lt;sip:8000@192.168.2.81;user=phone&gt;;tag=3515135869 To: &lt;sip:9000@192.168.2.81;user=phone&gt; Call-ID: 557188650@192.168.3.175 CSeq: 2 INVITE Contact: &lt;sip:8000@192.168.3.175;user=phone;transport=udp&gt; User-Agent: Cisco ATA v2.12 ata186 (0928a) Proxy-Authorization: Digest username="8000", realm="CISCO", nonce="3bd76584", uri="sip:9000@192.168.2.81", response="6e91de67ad976997ffac76f0398ef224" Expires: 300 Content-Length: 253 Content-Type: application/sdp v=0 o=8000 177738 177738 IN IP4 192.168.3.175 s=ATA186 Call c=IN IP4 192.168.3.175 t=0 0 m=audio 10000 RTP/AVP 0 18 8 101 a=rtpmap:0 PCMU/8000/1 a=rtpmap:18 G729/8000/1 a=rtpmap:8 PCMA/8000/1 a=rtpmap:101 telephone-event/8000 a=fmtp:101 0-15 </pre>

Table D-8 Log Listings (continued)

8.	<pre>SIP/2.0 100 Trying Via: SIP/2.0/UDP 192.168.2.81:5060;branch=c0b3510a-819f9d1a-ea43c345-9604747f-1 Via: SIP/2.0/UDP 192.168.3.175 Record-Route: &lt;sip:9000@192.168.2.81:5060;user=phone;maddr=192.168.2.81&gt; From: &lt;sip:8000@192.168.2.81;user=phone&gt;;tag=3515135869 To: &lt;sip:9000@192.168.2.81;user=phone&gt;;tag=100585329 Call-ID: 557188650@192.168.3.175 CSeq: 2 INVITE Server: Cisco ATA v2.12 ata186 (0928a) Content-Length: 0</pre>
9.	<pre>SIP/2.0 180 Ringing Via: SIP/2.0/UDP 192.168.2.81:5060;branch=c0b3510a-819f9d1a-ea43c345-9604747f-1 Via: SIP/2.0/UDP 192.168.3.175 Record-Route: &lt;sip:9000@192.168.2.81:5060;user=phone;maddr=192.168.2.81&gt; From: &lt;sip:8000@192.168.2.81;user=phone&gt;;tag=3515135869 To: &lt;sip:9000@192.168.2.81;user=phone&gt;;tag=100585329 Call-ID: 557188650@192.168.3.175 CSeq: 2 INVITE Server: Cisco ATA v2.12 ata186 (0928a) Content-Length: 0</pre>
10.	<pre>SIP/2.0 180 Ringing Via: SIP/2.0/UDP 192.168.3.175 Record-Route: &lt;sip:9000@192.168.2.81:5060;user=phone;maddr=192.168.2.81&gt; From: &lt;sip:8000@192.168.2.81;user=phone&gt;;tag=3515135869 To: &lt;sip:9000@192.168.2.81;user=phone&gt;;tag=100585329 Call-ID: 557188650@192.168.3.175 CSeq: 2 INVITE Server: Cisco ATA v2.12 ata186 (0928a) Content-Length: 0</pre>
11.	<pre>SIP/2.0 200 OK Via: SIP/2.0/UDP 192.168.2.81:5060;branch=c0b3510a-819f9d1a-ea43c345-9604747f-1 Via: SIP/2.0/UDP 192.168.3.175 Record-Route: &lt;sip:9000@192.168.2.81:5060;user=phone;maddr=192.168.2.81&gt; From: &lt;sip:8000@192.168.2.81;user=phone&gt;;tag=3515135869 To: &lt;sip:9000@192.168.2.81;user=phone&gt;;tag=100585329 Call-ID: 557188650@192.168.3.175 CSeq: 2 INVITE Contact: &lt;sip:9000@192.168.3.194;user=phone;transport=udp&gt; Server: Cisco ATA v2.12 ata186 (0928a) Content-Length: 199 Content-Type: application/sdp v=0 o=9000 179263 179263 IN IP4 192.168.2.194 s=ATA186 Call c=IN IP4 192.168.2.194 t=0 0 m=audio 10000 RTP/AVP 0 101 a=rtpmap:0 PCMU/8000/1 a=rtpmap:101 telephone-event/8000 a=fmtp:101 0-15</pre>



Table D-8 Log Listings (continued)

12.	<pre>SIP/2.0 200 OK Via: SIP/2.0/UDP 192.168.3.175 Record-Route: &lt;sip:9000@192.168.2.81:5060;user=phone;maddr=192.168.2.81 From: &lt;sip:8000@192.168.2.81;user=phone&gt;;tag=3515135869 To: &lt;sip:9000@192.168.2.81;user=phone;tag=100585329 Call-ID: 557188650@192.168.3.175 CSeq: 2 INVITE Contact: &lt;sip:9000@192.168.2.194;user=phone;transport=udp&gt; Server: Cisco ATA v2.12 ata186 (0928a) Content-Length: 199 Content-Type: application/sdp v=0 o=9000 179263 179263 IN IP4 192.168.2.194 s=ATA186 Call c=IN IP4 192.168.2.194 t=0 0 m=audio 10000 RTP/AVP 0 101 a=rtpmap:0 PCMU/8000/1 a=rtpmap:101 telephone-event/8000 a=fmtp:101 0-15</pre>
13.	<pre>ACK sip:9000@192.168.2.81;user=phone SIP/2.0 Route: &lt;sip:9000@192.168.2.194:5060;user=phone;transport=udp&gt; Via: SIP/2.0/UDP 192.168.3.175 From: &lt;sip:8000@192.168.2.81;user=phone&gt;;tag=3515135869 To: &lt;sip:9000@192.168.2.81;user=phone&gt;;tag=100585329 Call-ID: 557188650@192.168.3.175 CSeq: 2 ACK User-Agent: Cisco ATA v2.12 ata186 (0928a) Content-Length: 0</pre>
14.	<pre>ACK sip:9000@192.168.2.194;user=phone SIP/2.0 Via: SIP/2.0/UDP 192.168.2.81:5060;branch=c0b3510a-819f9d1a-ea43c345-9604747f-1 Via: SIP/2.0/UDP 192.168.3.175 From: &lt;sip:8000@192.168.2.81;user=phone&gt;;tag=3515135869 To: &lt;sip:9000@192.168.2.81;user=phone&gt;;tag=100585329 Call-ID: 557188650@192.168.3.175 CSeq: 2 ACK User-Agent: Cisco ATA v2.12 ata186 (0928a) Content-Length: 0</pre>
15.	<pre>BYE sip:9000@192.168.2.81;user=phone SIP/2.0 Route: &lt;sip:9000@192.168.2.194:5060;user=phone;transport=udp&gt; Via: SIP/2.0/UDP 192.168.3.175 From: &lt;sip:8000@192.168.2.81;user=phone&gt;;tag=3515135869 To: &lt;sip:9000@192.168.2.81;user=phone&gt;;tag=100585329 Call-ID: 557188650@192.168.3.175 CSeq: 3 BYE User-Agent: Cisco ATA v2.12 ata186 (0928a) Content-Length: 0</pre>
16.	<pre>SIP/2.0 100 Trying Via: SIP/2.0/UDP 19.168.3.175 Call-ID: 557188650@192.168.3.175 From: &lt;sip:8000@192.168.2.81;user=phone&gt;;tag=3515135869 To: &lt;sip:9000@192.168.2.81;user=phone&gt;;tag=100585329 CSeq: 3 BYE Content-Length: 0</pre>

**Table D-8 Log Listings (continued)**

<b>17.</b>	<pre> BYE sip:9000@192.168.2.194;user=phone SIP/2.0 Via: SIP/2.0/UDP 192.168.2.81:5060;branch=424f3898-9ef87cec-82179ac3-50eeb1d3-1 Via: SIP/2.0/UDP 192.168.3.175 From: &lt;sip:8000@192.168.2.81;user=phone&gt;;tag=3515135869 To: &lt;sip:9000@192.168.2.81;user=phone&gt;;tag=100585329 Call-ID: 557188650@192.168.3.175 CSeq: 3 BYE User-Agent: Cisco ATA v2.12 ata186 (0928a) Content-Length: 0 </pre>
<b>18.</b>	<pre> SIP/2.0 200 OK Via: SIP/2.0/UDP 192.168.2.81:5060;branch=424f3898-9ef87cec-82179ac3-50eeb1d3-1 Via: SIP/2.0/UDP 192.168.3.175 From: &lt;sip:8000@192.168.2.81;user=phone&gt;;tag=3515135869 To: &lt;sip:9000@192.168.2.81;user=phone&gt;;tag=100585329 Call-ID: 557188650@192.168.3.175 CSeq: 3 BYE Server: Cisco ATA v2.12 ata186 (0928a) Content-Length: 0 </pre>
<b>19.</b>	<pre> SIP/2.0 200 OK Via: SIP/2.0/UDP 192.168.3.175 From: &lt;sip:8000@192.168.2.81;user=phone&gt;;tag=3515135869 To: &lt;sip:9000@192.168.2.81;user=phone&gt;;tag=100585329 Call-ID: 557188650@192.168.3.175 CSeq: 3 BYE Server: Cisco ATA v2.12 ata186 (0928a) Content-Length: 0 </pre>