



Migration Guide for Cisco UCS Fabric Interconnects, Release 6.0

First Published: 2025-09-02

Last Modified: 2026-03-16

Americas Headquarters

Cisco Systems, Inc.
170 West Tasman Drive
San Jose, CA 95134-1706
USA
<http://www.cisco.com>
Tel: 408 526-4000
800 553-NETS (6387)
Fax: 408 527-0883

THE SPECIFICATIONS AND INFORMATION REGARDING THE PRODUCTS IN THIS MANUAL ARE SUBJECT TO CHANGE WITHOUT NOTICE. ALL STATEMENTS, INFORMATION, AND RECOMMENDATIONS IN THIS MANUAL ARE BELIEVED TO BE ACCURATE BUT ARE PRESENTED WITHOUT WARRANTY OF ANY KIND, EXPRESS OR IMPLIED. USERS MUST TAKE FULL RESPONSIBILITY FOR THEIR APPLICATION OF ANY PRODUCTS.

THE SOFTWARE LICENSE AND LIMITED WARRANTY FOR THE ACCOMPANYING PRODUCT ARE SET FORTH IN THE INFORMATION PACKET THAT SHIPPED WITH THE PRODUCT AND ARE INCORPORATED HEREIN BY THIS REFERENCE. IF YOU ARE UNABLE TO LOCATE THE SOFTWARE LICENSE OR LIMITED WARRANTY, CONTACT YOUR CISCO REPRESENTATIVE FOR A COPY.

The Cisco implementation of TCP header compression is an adaptation of a program developed by the University of California, Berkeley (UCB) as part of UCB's public domain version of the UNIX operating system. All rights reserved. Copyright © 1981, Regents of the University of California.

NOTWITHSTANDING ANY OTHER WARRANTY HEREIN, ALL DOCUMENT FILES AND SOFTWARE OF THESE SUPPLIERS ARE PROVIDED "AS IS" WITH ALL FAULTS. CISCO AND THE ABOVE-NAMED SUPPLIERS DISCLAIM ALL WARRANTIES, EXPRESSED OR IMPLIED, INCLUDING, WITHOUT LIMITATION, THOSE OF MERCHANTABILITY, FITNESS FOR A PARTICULAR PURPOSE AND NON-INFRINGEMENT OR ARISING FROM A COURSE OF DEALING, USAGE, OR TRADE PRACTICE.

IN NO EVENT SHALL CISCO OR ITS SUPPLIERS BE LIABLE FOR ANY INDIRECT, SPECIAL, CONSEQUENTIAL, OR INCIDENTAL DAMAGES, INCLUDING, WITHOUT LIMITATION, LOST PROFITS OR LOSS OR DAMAGE TO DATA ARISING OUT OF THE USE OR INABILITY TO USE THIS MANUAL, EVEN IF CISCO OR ITS SUPPLIERS HAVE BEEN ADVISED OF THE POSSIBILITY OF SUCH DAMAGES.

Any Internet Protocol (IP) addresses and phone numbers used in this document are not intended to be actual addresses and phone numbers. Any examples, command display output, network topology diagrams, and other figures included in the document are shown for illustrative purposes only. Any use of actual IP addresses or phone numbers in illustrative content is unintentional and coincidental.

All printed copies and duplicate soft copies of this document are considered uncontrolled. See the current online version for the latest version.

Cisco has more than 200 offices worldwide. Addresses and phone numbers are listed on the Cisco website at www.cisco.com/go/offices.

Cisco and the Cisco logo are trademarks or registered trademarks of Cisco and/or its affiliates in the U.S. and other countries. To view a list of Cisco trademarks, go to this URL: <https://www.cisco.com/c/en/us/about/legal/trademarks.html>. Third-party trademarks mentioned are the property of their respective owners. The use of the word partner does not imply a partnership relationship between Cisco and any other company. (1721R)

© 2025–2026 Cisco Systems, Inc. All rights reserved.



CONTENTS

CHAPTER 1	New and Changed Information	1
	New and Changed Information for This Release	1

CHAPTER 2	Overview of Cisco UCS Fabric Interconnects	5
	Cisco UCS 6000 Series Fabric Interconnects	5
	Overview of Cisco UCS 6652 Fabric Interconnect	5
	Cisco UCS 6652 Fabric Interconnect	6
	Overview of Cisco UCS 6664 Fabric Interconnect	8
	Cisco UCS 6664 Fabric Interconnect	8
	Cisco UCS 6500 Series Fabric Interconnects	11
	Cisco UCS 6536 Fabric Interconnect Overview	11
	Cisco UCS 6536 Fabric Interconnect	12
	Cisco UCS 6400 Series Fabric Interconnects	16
	Cisco UCS 6400 Series Fabric Interconnect Overview	16
	Cisco UCS 64108 Fabric Interconnect	16
	Cisco UCS 6454 Fabric Interconnect	18
	Ports on the Cisco UCS Fabric Interconnects	19

CHAPTER 3	Migrating to Cisco UCS 6600 Series Fabric Interconnects	23
	Cisco UCS 6600 Series Fabric Interconnect Migration	23
	Migrating Cisco UCS Fabric Interconnects: 6500 to 6600 Series	23
	Cisco UCS 6500 Series Fabric Interconnect Migration Considerations	23
	Migrating from Cisco UCS 6536 Fabric Interconnect to Cisco UCS 6600 Series Fabric Interconnect	26
	Migrating Cisco UCS Fabric Interconnects: 6400 to 6600 Series	29
	Considerations for Migrating Cisco UCS 6400 Series Fabric Interconnects	29

Migrating from UCS 6400 Series Fabric Interconnects to Cisco UCS 6600 Series Fabric Interconnects 33

CHAPTER 4

Migrating to Cisco UCS 6500 Series Fabric Interconnects 37

Cisco UCS 6400 Series Fabric Interconnect Migration 37

Cisco UCS 6400 Series Fabric Interconnect Migration Considerations 37

Validating Feature Configurations for Cisco UCS 6536 before Upgrade 40

Considerations for migrating Cisco UCS 6400 Series Fabric Interconnects to Cisco UCS 6500 Series Fabric Interconnects with Cisco UCS Central 40

Migrating from UCS 6400 Series Fabric Interconnects to UCS 6536 Fabric Interconnects 41

CHAPTER 5

Migrating to Cisco UCS 6400 Series Fabric Interconnect 45

Cisco UCS 6454 Fabric Interconnect to Cisco UCS 64108 Fabric Interconnect Migration 45

Cisco UCS 6400 Series Fabric Interconnect Migration Considerations 45

Validating Feature Configurations for Cisco UCS 64108 Fabric Interconnect before Upgrade 47

Considerations for migrating Cisco UCS 6454 Fabric Interconnects to Cisco UCS 64108 Fabric Interconnects with Cisco UCS Central 47

Migrating from UCS 6454 Fabric Interconnects to UCS 64108 Fabric Interconnects 48

CHAPTER 6

Appendix 53

Appendix 53



CHAPTER 1

New and Changed Information

- [New and Changed Information for This Release, on page 1](#)

New and Changed Information for This Release

The following table provides an overview of the changes to this guide for Cisco UCS Manager, Release 6.0

Table 1: New Features and Changed Behavior in Cisco UCS Manager, Release 6.0(2b)

Feature	Description	Where Documented
Support for Cisco UCS 6652 Fabric Interconnect	Cisco UCS Manager now supports the Cisco UCS 6652 Fabric Interconnect, adding it to the portfolio of sixth-generation fabric interconnects within the Cisco UCS 6600 Series.	<ul style="list-style-type: none">• Overview of Cisco UCS 6652 Fabric Interconnect, on page 5• Cisco UCS 6652 Fabric Interconnect, on page 6

Feature	Description	Where Documented
Migrating Cisco UCS 6500 Series Fabric Interconnects to Cisco UCS 6600 Series Fabric Interconnects	Cisco UCS Manager supports migration of UCS 6536 Fabric Interconnects to UCS 6652 Fabric Interconnect.	<ul style="list-style-type: none"> • Validating Feature Configurations for Cisco UCS 6600 Series Fabric Interconnect before Upgrade, on page 25 • Cisco UCS 6500 Series Fabric Interconnect Migration Considerations, on page 23 • Considerations for migrating Cisco UCS 6536 Fabric Interconnect to Cisco UCS 6600 Series Fabric Interconnect with Cisco UCS Central, on page 26 • Migrating from Cisco UCS 6536 Fabric Interconnect to Cisco UCS 6600 Series Fabric Interconnect, on page 26
Migrating Cisco UCS 6400 Series Fabric Interconnects to Cisco UCS 6600 Series Fabric Interconnects	Cisco UCS Manager supports migration of UCS 6454 and 64108 Fabric Interconnects to UCS 6652 Fabric Interconnect.	<ul style="list-style-type: none"> • Considerations for Migrating Cisco UCS 6400 Series Fabric Interconnects, on page 29 • Validating Feature Configurations for Cisco UCS 6664 before Upgrade, on page 31 • Considerations for migrating Cisco UCS 6400 Series Fabric Interconnects to UCS 6664 Fabric Interconnects with Cisco UCS Central, on page 32 • Migrating from UCS 6400 Series Fabric Interconnects to Cisco UCS 6600 Series Fabric Interconnects, on page 33

Table 2: New Features and Changed Behavior in Cisco UCS Manager, Release 6.0(1b)

Feature	Description	Where Documented
Migrating Cisco UCS 6500 Series Fabric Interconnects to Cisco UCS 6600 Series Fabric Interconnects	Cisco UCS Manager supports migration of UCS 6536 Fabric Interconnects to UCS 6664 Fabric Interconnect.	<ul style="list-style-type: none"> • Validating Feature Configurations for Cisco UCS 6600 Series Fabric Interconnect before Upgrade, on page 25 • Cisco UCS 6500 Series Fabric Interconnect Migration Considerations, on page 23 • Considerations for migrating Cisco UCS 6536 Fabric Interconnect to Cisco UCS 6600 Series Fabric Interconnect with Cisco UCS Central, on page 26 • Migrating from Cisco UCS 6536 Fabric Interconnect to Cisco UCS 6600 Series Fabric Interconnect, on page 26
Migrating Cisco UCS 6400 Series Fabric Interconnects to Cisco UCS 6600 Series Fabric Interconnects	Cisco UCS Manager supports migration of UCS 6454 and 64108 Fabric Interconnects to UCS 6664 Fabric Interconnect.	<ul style="list-style-type: none"> • Considerations for Migrating Cisco UCS 6400 Series Fabric Interconnects, on page 29 • Validating Feature Configurations for Cisco UCS 6664 before Upgrade, on page 31 • Considerations for migrating Cisco UCS 6400 Series Fabric Interconnects to UCS 6664 Fabric Interconnects with Cisco UCS Central, on page 32 • Migrating from UCS 6400 Series Fabric Interconnects to Cisco UCS 6600 Series Fabric Interconnects, on page 33



CHAPTER 2

Overview of Cisco UCS Fabric Interconnects

- [Cisco UCS 6000 Series Fabric Interconnects, on page 5](#)
- [Cisco UCS 6500 Series Fabric Interconnects, on page 11](#)
- [Cisco UCS 6400 Series Fabric Interconnects, on page 16](#)
- [Ports on the Cisco UCS Fabric Interconnects, on page 19](#)

Cisco UCS 6000 Series Fabric Interconnects

Overview of Cisco UCS 6652 Fabric Interconnect

The Cisco UCS 6652 Fabric Interconnect is a 1-rack unit (RU), fixed-port system designed for Top-of-Rack deployment in data centers. The fabric interconnect has both Ethernet and unified ports. Unified ports provide Fibre Channel over Ethernet (FCoE), Fibre Channel, and Ethernet. By supporting these different protocols, you can use a single multi-protocol Virtual Interface Card (VIC) in your servers.

The UCS 6652 Fabric Interconnect supports an array of Gigabit Ethernet (GbE), Fibre Channel (FC), and Fibre Channel over Ethernet (FCoE) ports to offer connectivity to peer data center devices. This device is also ideal for high-performance, scalable, and secure networking in modern data centers.

The UCS 6652 Fabric Interconnect includes:

The Cisco UCS 6652 Fabric Interconnect includes:

- **Total Ports:** 52
- **Ethernet SFP28 Ports:** 32 (10/25/50 Gbps)
- **Unified Ports:** 16 (supporting 10/25 Gbps Ethernet, FCoE, and 16/32/64 Gbps Fibre Channel)
- **Uplink Ports:** 4 QSFP ports (supporting 40/100/400 Gbps Ethernet)
- **Form Factor:** 1RU fixed-port system for dense connectivity
- **Operational Modes:** Fibre Channel end-host and switch-mode support

Cisco UCS 6652 Fabric Interconnect

The Cisco UCS 6652 Fabric Interconnect (UCSC-FI-6652) is a 1-rack unit (1RU), fixed-port system designed for Top-of-Rack (TOR) deployment in data centers. It serves as a central component in the Cisco UCS system, providing both network connectivity and management capabilities. It connects servers to the LAN or SAN, facilitating a unified computing environment. Management of the fabric interconnect can be performed through its console interface for initial setup, and subsequently via its management interface within Cisco UCS Manager.

Figure 1: Cisco UCS 6652 Fabric Interconnect Front View

Front View



Key features of Cisco UCS 6652 Fabric Interconnect:

Ports

- **32 SFP28 ports (Ports 1-16 and 33-48):** These ports operate at 10/25/50 Gbps Ethernet/FCoE.
- **16 Unified Ports (SFP28 ports 17-32):** These flexible ports can support:
 - 10/25/50 Gbps SFP28 Ethernet/FCoE
 - 16/32/64 Gbps Fibre Channel
- **4 QSFP-DD Uplink ports (Ports 49-52):** These ports are recommended for uplink connections and support 40/100/400 Gbps Ethernet/FCoE.
- **MACsec-capable Ports:** A total of 36 ports support MACsec, including ports 1-16 and 33-48, and all 4 QSFP-DD ports (49-52).

Breakout Support: Breakout is supported exclusively on the 4 QSFP-DD ports (49-52). Each port can be broken out into 2 or 4 logical ports (4x100G or 2x100G) depending on the transceiver.

Fan modules (5): These are variable speed fans located on the front panel providing 3+1 redundancy and are hot-swappable.

Power supply modules (2): Two identical 1400W AC power supply units are provided on the front panel for 1+1 redundancy and are hot-swappable.

Management/Console: Includes Network management port, RS-232 serial console port, and L1/L2 high-availability ports (RJ-45).

Figure 2: Cisco UCS 6652 Fabric Interconnect Chassis Overall Front View

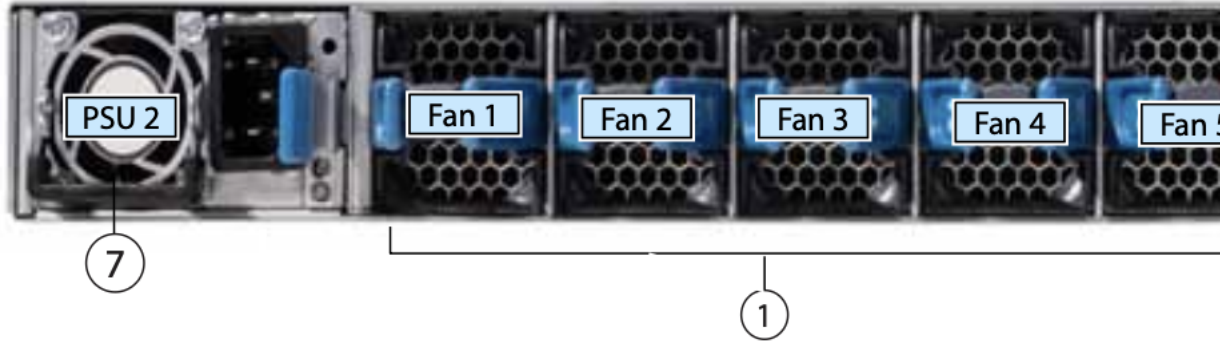

1 Cooling fans (hot swappable, 3+1 redundancy)	2 Network management port □ (RJ-45 connector)
3 USB port	4 RS-232 serial console port □ (RJ-45 connector)
5 L1 high-availability ports □ (RJ-45 connector)	6 L2 high-availability ports □ (RJ-45 connector)
7 Power supplies Two identical AC PSUs, hot-swappable, 1+1 redundancy	--

Figure 3: Cisco UCS 6652 Fabric Interconnect Chassis Overall Rear View

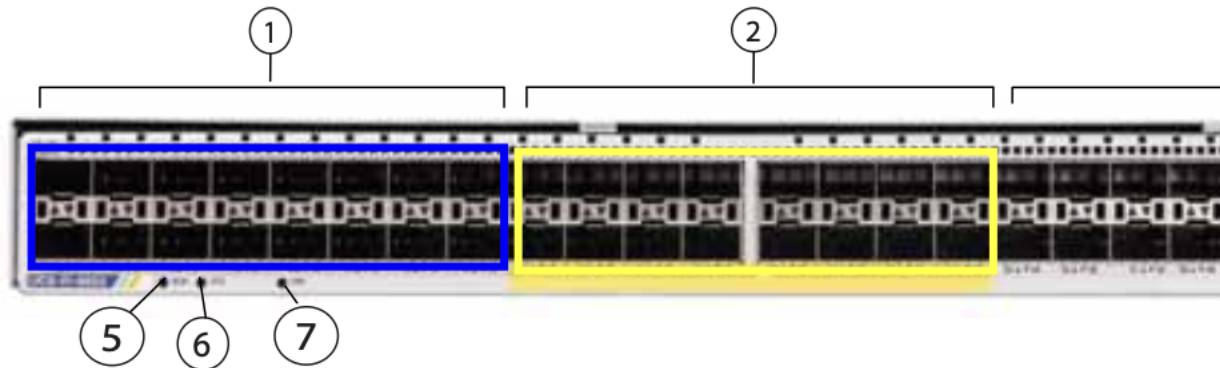

1	Ports 1-16 10/25/50 Gbps Ethernet/FCoE	2	Unified Ports • 10/25/50 Gbps Ethernet/FCoE or • 16/32/64 Gbps FC
3	Ports 33-48 10/25/50 Gbps Ethernet/FCoE	4	Recommended uplink ports 49-52 40/100/400 Gbps Ethernet/FCoE
5	System Environment (fan fault) LED	6	System Status LED
7	Beacon LED		

Overview of Cisco UCS 6664 Fabric Interconnect

The Cisco UCS 6664 Fabric Interconnect is a 2-rack unit (RU), fixed-port system designed for Top-of-Rack deployment in data centers. The fabric interconnect has both Ethernet and unified ports. Unified ports provide Fibre Channel over Ethernet (FCoE), Fibre Channel, NVMe over Fabric, and Ethernet. By supporting these different protocols, you can use a single multi-protocol Virtual Interface Card (VIC) in your servers.

The UCS 6664 Fabric Interconnect supports an array of Gigabit Ethernet (GbE), Fibre Channel (FC), and Fibre Channel over Ethernet (FCoE) ports to offer connectivity to peer data center devices. This device is also ideal for high-performance, scalable, and secure networking in modern data centers.

The Cisco UCS 6664 Fabric Interconnect includes:

- 64 total ports
 - 48 ports of 40/100 Gbps
 - 16 unified ports
 - Supports 10/25/50 Gbps for Ethernet and Fibre Channel over Ethernet (FCoE)
 - Supports 10/25 Gbps or 16/32/64 Gbps Fibre Channel for maximum flexibility
- 2RU fixed form factor for dense 100 Gbps connectivity
- Fibre Channel end-host and switch-mode support

Cisco UCS 6664 Fabric Interconnect

The Cisco UCS 6664 Fabric Interconnect (UCSC-FI-6664) is a 2-rack unit (2RU), fixed-port system designed for Top-of-Rack (TOR) deployment in data centers. It serves as a central component in the Cisco UCS system, providing both network connectivity and management capabilities. It connects servers to the LAN or SAN, facilitating a unified computing environment. Management of the fabric interconnect can be performed through its console interface for initial setup, and subsequently via its management interface within Cisco UCS Manager.

Figure 4: Cisco UCS 6664 Fabric Interconnect Front View



Key features of Cisco UCS 6664 Fabric Interconnect:

• Ports

48 QSFP ports: These ports are divided into two groups:

- **QSFP Ports 1-24:** Support Gigabit Ethernet links at speeds of 10 Gbps (through QSA transceivers), and 25 Gbps, 40 Gbps, and 100 Gbps (through QSA28 transceivers). FCoE links are also supported, but standard FC links are not.
- **QSFP Ports 41-64:** Support only Gigabit Ethernet or Fibre Channel over Ethernet (FCoE) links at speeds of 10 Gbps (through QSA transceivers), and 25 Gbps, 40 Gbps, or 100 Gbps (through QSA28 transceivers). Standard Fibre Channel links are not supported on these ports.

• **16 Unified Ports (SFP ports 25-40):** These ports, indicated by yellow silk screening, are flexible and support:

- Fibre Channel: 16 Gbps, 32 Gbps, or 64 Gbps. These are the only ports on the Fabric Interconnect that support standard FC traffic.
- Gigabit Ethernet or Fibre Channel over Ethernet (FCoE): 10 Gbps or 25 Gbps.

• **MACsec-capable Ports:** QSFP ports 49-64 are recommended as uplinks and support Media Access Control Security (MACsec) on Gigabit Ethernet links, but not FCoE links.

• **Breakout Support:** Breakout port support for this fabric interconnect currently not available.

• Secure Boot Support

• **Fan modules (4):** These are port-side exhaust fan modules (NXASFAN-160CFM2-PE) with blue coloring, providing redundant and load-sharing cooling.

• **Power supply modules (2):** Two 1400-W AC power supply modules (NXA-PAC-1400W-PE) are provided for 1+1 redundancy. These also feature port-side exhaust airflow with blue coloring.

Figure 5: Cisco UCS 6664 Fabric Interconnect Front Panel View

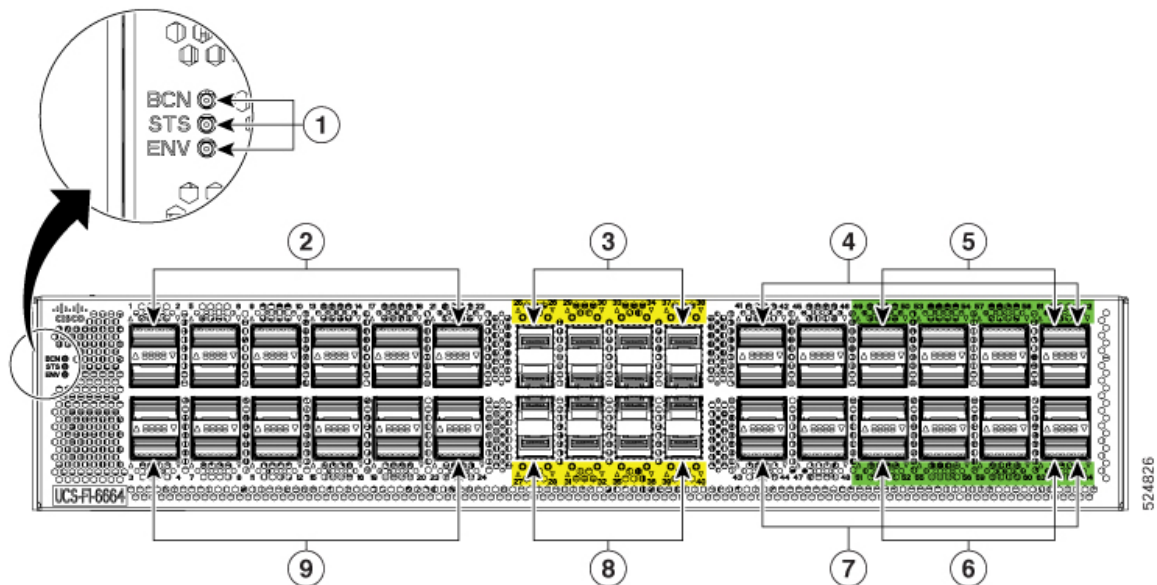

1	Beacon (BCN), Status (STS), and Environment (ENV) LEDs	2	QSFP Ports 1, 2, 5, 6, 9,10, 13, 14, 17, 18, 21, and 22. Ports are arranged vertically in pairs and support QSA or QSA28 transceivers.
3	SFP Ports 25, 26, 29, 30, 33, 34, 37, and 38 are Unified Ports	4	QSFP Ports 41, 42, 45, 46, 49, 50, 53, 54, 57,58, 61, and 62.
5	MACsec-capable QSFP ports 49, 50, 53, 54, 57, 58, 61, and 62.	6	MACsec-capable QSFP ports 51, 52, 55, 56, 59, 60, 63, and 64.
7	QSFP Ports 43, 44,47, 48, 51, 52, 55, 56, 59, 60, 63, and 64.	8	SFP Ports 27, 28, 31, 32, 35, 36, 39, and 40 are Unified Ports
9	QSFP Ports 3, 4, 7, 8, 11,12, 15, 16, 19, 20, 23, and 24. Ports are arranged vertically in pairs and support QSA or QSA28 transceivers.		

Figure 6: Cisco UCS 6664 Fabric Interconnect Rear Panel View

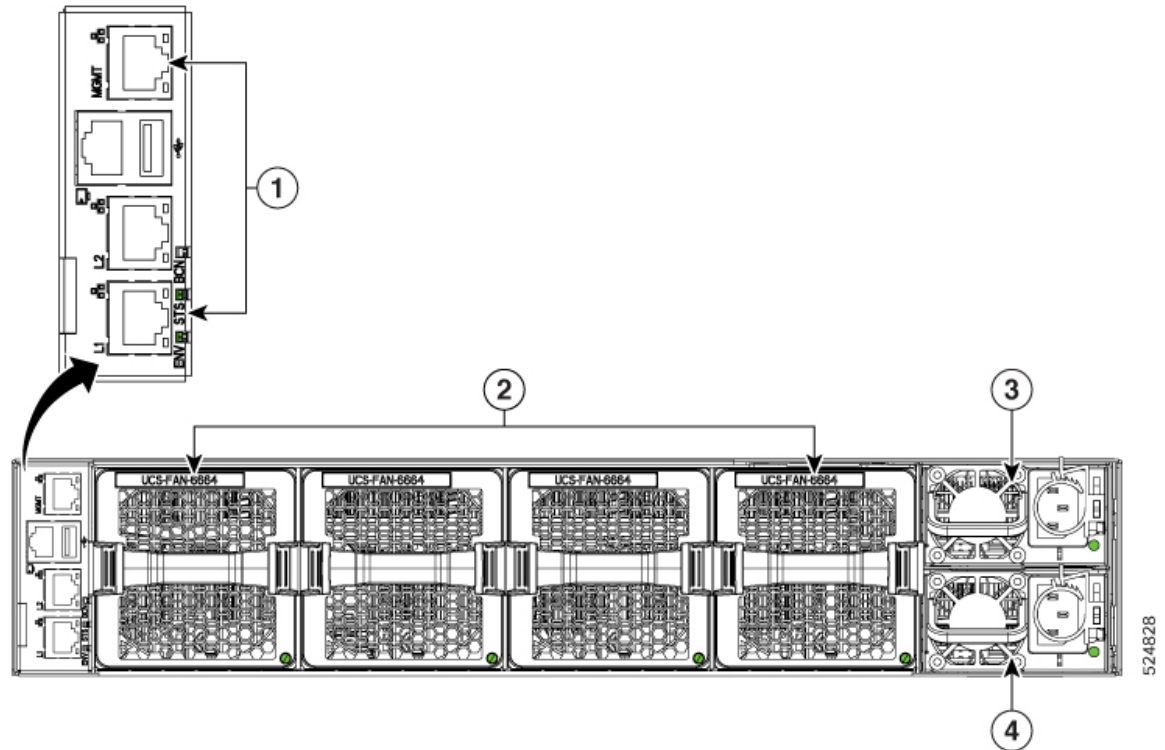

1 Management Module	2 Fan Modules, numbered one through four with fan 1 on the left and fan four on the right.
3 Power Supply 1	4 Power Supply 2

524828

Cisco UCS 6500 Series Fabric Interconnects

Cisco UCS 6536 Fabric Interconnect Overview

The Cisco UCS 6536 Fabric Interconnect is a core part of the Cisco Unified Computing System, providing both network connectivity and management capabilities for the system. The Cisco UCS 6536 Fabric Interconnect provides the communication backbone and management connectivity for UCS B-series blade servers and UCS C-series rack servers.

Cisco UCS 6500 Series Fabric Interconnects currently include Cisco UCS 6536 Fabric Interconnect. All servers attached to a Cisco UCS 6536 Fabric Interconnect become part of a single, highly available management domain. In addition, by supporting a unified fabric, Cisco UCS 6536 Fabric Interconnect provides both LAN and SAN connectivity for all servers within its domain.

The Cisco UCS 6536 Fabric Interconnect supports multiple traffic classes over a lossless Ethernet fabric from the server through the fabric interconnect.

Cisco UCS 6536 Fabric Interconnect

The Cisco UCS 6536 Fabric Interconnect (UCSC-FI-6536) is a One-rack unit (1RU), top of rack (TOR), fixed-port data center platform that provides both network connectivity and management capabilities to the Cisco UCS system.

The fabric interconnect can provide Ethernet and Fibre Channel connectivity to the servers in the system. The servers connect to the fabric interconnect, and then to the LAN or SAN.

Cisco UCS Manager on UCS 6536 Fabric Interconnect supports Cisco UCS X-Series Compute Nodes, B-Series Blade Servers and C-Series Rack Servers, Cisco UCS S-Series Storage Servers, as well as the associated storage resources and networks.

High availability and redundancy can be achieved by connecting a pair of fabric interconnects to each other through L1 or L2 ports in cluster mode configuration.

Each Cisco UCS 6536 Fabric Interconnect offers the following features:

- Thirty-six QSFP28 ports capable of 100G including 4 unified ports (33-36). Ports also support:
 - Autonegotiating with peer devices to speeds of 100G, 40G, 25G, 10G, and 1G.
 - Port breakout is supported for Ethernet ports (1-32) and Unified ports (33-36).
 - Ethernet breakout is supported on switch ports 1 through 36 when each port is configured with a breakout cable.
 - The Dynamic Ethernet Breakout feature enables converting a standard Ethernet port to a breakout port on-the-fly so that you do not need to reboot the Fabric Interconnect. Dynamic Ethernet Breakout also supports converting breakout ports back to a standard Ethernet port without a reboot.
 - FC breakout is supported on ports 33 through 36 wherein each port is configured with a four-port breakout cable. For example 1/33/1, 1/33/2, 1/33/3, and 1/33/4 are the four FC breakout ports on the physical port 33.



Note Fibre Channel support is only available through the configuration of Unified Ports (33-36) as FC breakout port.

- FC breakout ports support peer communication at fixed speeds of 8Gbps, 16 Gbps, and 32 Gbps.
- All four FC breakout ports must be configured with the same speed. Mixed speeds on a QSFP port's FC breakout ports are not supported.
- Using breakout ports enables the fabric interconnect to support the maximum 16 FC ports supported by Fibre Channel.



Note

- Converting from Ethernet to FC breakout ports, or FC breakout ports back to Ethernet, requires a reboot/reload after changing the breakout type.
- FCoE storage ports are not supported.

- One management port (one 10/100/1000BASE-T port)
- Two L1/L2 Ethernet RJ-45 ports for high availability or cluster configurations. Ethernet ports support 10/100/1000Mb speed.
- One console port (RS-232)
- One USB 3.0 port
- CPU: 4 Core, 1.8GHz, Intel 5th-Generation core processor
- Memory:
 - 32 GB DDR4 DIMMs
 - 128 GB M.2 SSD Flash Drive
 - 32 GB Boot Flash (16 MB primary, and 16 MB standby/golden)

This fabric interconnect includes the following user-replaceable components:

- Fan modules (6), each is a port-side exhaust fan module with dark grey latch coloring (UCS-FAN-6536).
- Power supply modules (2). One power supply module (PSU) is the active module for operations, and the second PSU is the standby for redundancy [1+1]) with the following choices:
 - 1100-W AC power supply with dark grey latch coloring (UCS-PSU-6536-AC)



Note All fan modules and power supplies must use the same airflow direction.

The following figure shows the fabric interconnect features on the port side of the chassis.

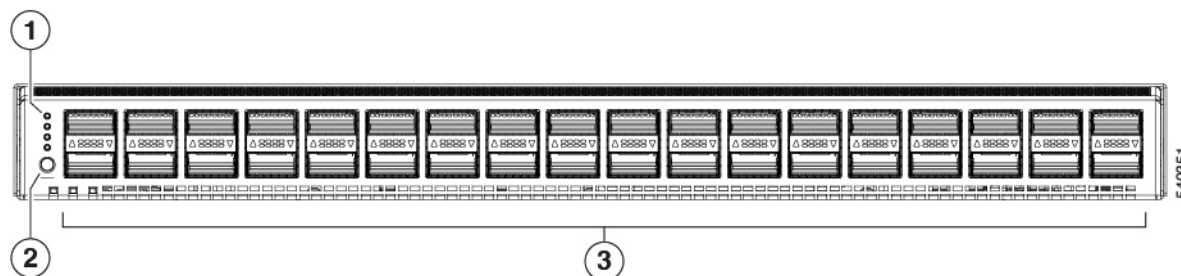

1	LEDs	3	36 40/100-Gigabit QSFP28 ports
2	Lane Select button		

To determine which transceivers, adapters, and cables are support the fabric interconnect, see the [Cisco Transceiver Modules Compatibility Information](#) document.

The following figure shows the fabric interconnect features on the power supply side of the chassis.

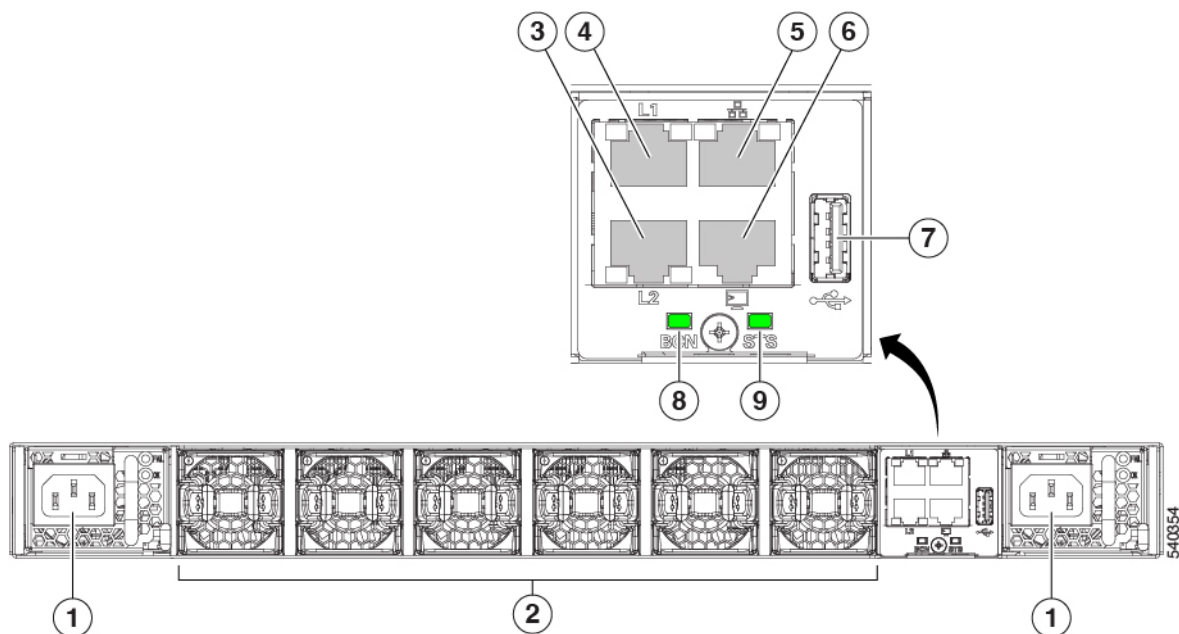

1	Power supply modules (1 or 2) (AC power supplies shown) with slots numbered 1 (left) and 2 (right).	2	Fan modules (6) with slots numbered from 1 (left) to 6 (right).
3	Layer 2 (L2) Ethernet port, 10/100/100Mb autonegotiating. Supports high availability (HA) or clustering through an RJ-45 port.	4	Layer 1 (L1) Ethernet port, 10/100/100Mb autonegotiating. Supports high availability (HA) or clustering through an RJ-45 port.
5	Ethernet network management port (RJ45), 10/100/1000Mb autonegotiating	6	Serial Console port (RJ45), 9600 baud.
7	USB 3.0/2.0 port Supports booting the system and downloading scripts.	8	Beacon (BCN) LED
9	Status (STS) LED	-	

The following figure shows the side of the chassis.

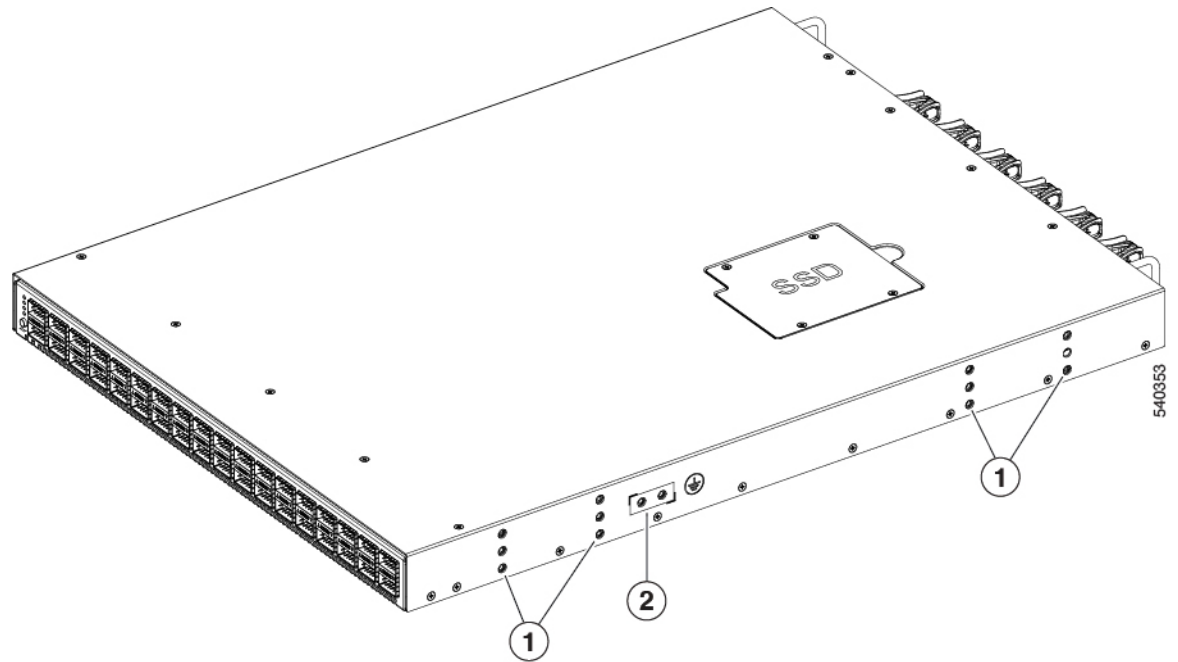

1	Screw holes for mounting brackets	2	Grounding pad
---	-----------------------------------	---	---------------

Plan to position the ports in a hot aisle so that fans and power supplies intake air from the cold aisle, blow the cool air through the fabric interconnect, and exhaust the heated air into the hot aisle.

The fan and power supply modules are field replaceable. You can replace one fan module or one power supply module during operations so long as the other modules are installed and operating. If you have only one power supply installed, you can install the replacement power supply in the open slot before removing the original power supply.



Note All fan and power supply modules must have the same direction of airflow. Otherwise, the fabric interconnect can overheat and shut down.



Caution Because fans and power supply modules have port-side exhaust airflow (blue coloring for fan modules), you must locate the ports in the hot aisle. If you locate the air intake in a hot aisle, the fabric interconnect can overheat and shut down.

Cisco UCS 6400 Series Fabric Interconnects

Cisco UCS 6400 Series Fabric Interconnect Overview

Cisco UCS 6400 Series Fabric Interconnect provides both network connectivity and management capabilities to the Cisco UCS system. The fabric interconnect provides Ethernet and Fibre Channel to the servers in the system, the servers connect to the fabric interconnect, and then to the LAN or SAN.

Each Cisco UCS 6400 Series Fabric Interconnect runs Cisco UCS Manager to fully manage all Cisco UCS elements. The fabric interconnect supports 10/25 Gigabit ports in the fabric with 40/100 Gigabit uplink ports. High availability can be achieved when a Cisco UCS 6400 Series Fabric Interconnect is connected to another Cisco UCS 6400 Series Fabric Interconnect through the L1 or L2 port on each device.

Cisco UCS 6400 Series Fabric Interconnect consists of:

- Cisco UCS 6454 Fabric Interconnects
- Cisco UCS 64108 Fabric Interconnects

The Cisco UCS 6400 Series fabric interconnect supports Cisco UCS B-Series Blade Servers, UCS 5108 B-Series Server Chassis, C-Series Rack Servers, and UCS S-Series Storage Servers.

Cisco UCS 64108 Fabric Interconnect

The Cisco UCS 64108 Fabric Interconnect is a 2 RU top-of-rack (TOR) switch that mounts in a standard 19-inch rack such as the Cisco R Series rack.

The high-density Cisco UCS 64108 Fabric Interconnect has 96 10/25 Gb SFP28 ports and 12 40/100 Gb QSFP28 ports. Each 40/100 Gb port can break out into 4 x 10/25 Gb uplink ports. Ports 1 - 16 are unified ports that support 10/25 GbE or 8/16/32G Fibre Channel speeds. Ports 89-96 support 1Gbps Ethernet speeds.

The Cisco UCS 64108 Fabric Interconnect supports either:

- Eight FCoE port channels
- Or Four SAN port channels
- or Four SAN port channels and four FCoE port channels

The Cisco UCS 64108 Fabric Interconnect also has one network management port, one RS-232 serial console port for setting the initial configuration, and one USB port for saving or loading configurations. The FI also includes L1/L2 ports for connecting two fabric interconnects in a high-availability configuration.

The Cisco UCS 64108 Fabric Interconnect also contains a CPU board that consists of:

- Intel Xeon Processor, 6 core
- 64 GB of RAM
- 8 MB of NVRAM (4 x NVRAM chips)
- 128 GB SSD (bootflash)

Figure 7: Cisco UCS 64108 Fabric Interconnect Rear View

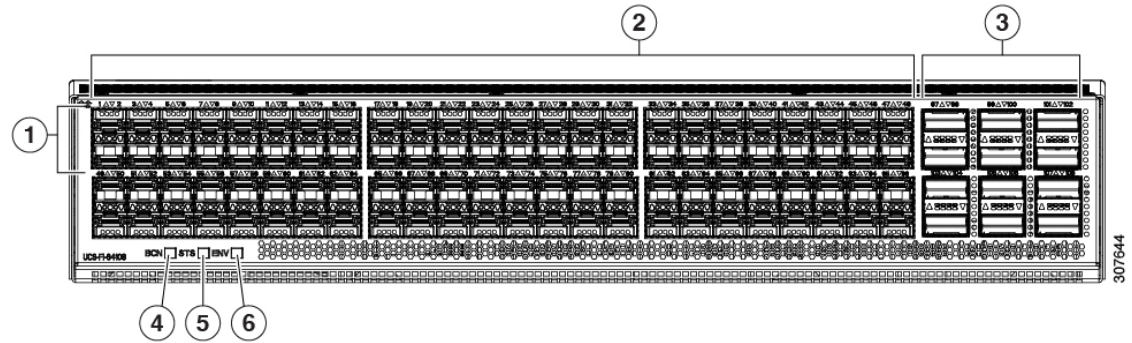

1	Ports 1-16 Unified ports: <ul style="list-style-type: none"> • 10/25 Gbps Ethernet or FCoE • 8/16/32 Gbps Fibre Channel 	2	Ports 17-88 (10/25 Gbps Ethernet or FCoE)
3	Ports 89-96 <ul style="list-style-type: none"> • 10/25 Gbps Ethernet or FCoE • 1 Gbps Ethernet 	4	Uplink Ports 97-108 (40/100 Gbps Ethernet or FCoE) Each of these ports can be 4 x 10/25 Gbps Ethernet or FCoE uplink ports when using a breakout cable.
5	System environment (fan fault) LED	6	System status LED
7	Beacon LED		

The Cisco UCS 64108 Fabric Interconnect has two power supplies (redundant as 1+1) and three fans (redundant as 2+1).

Figure 8: Cisco UCS 64108 Fabric Interconnect Front View

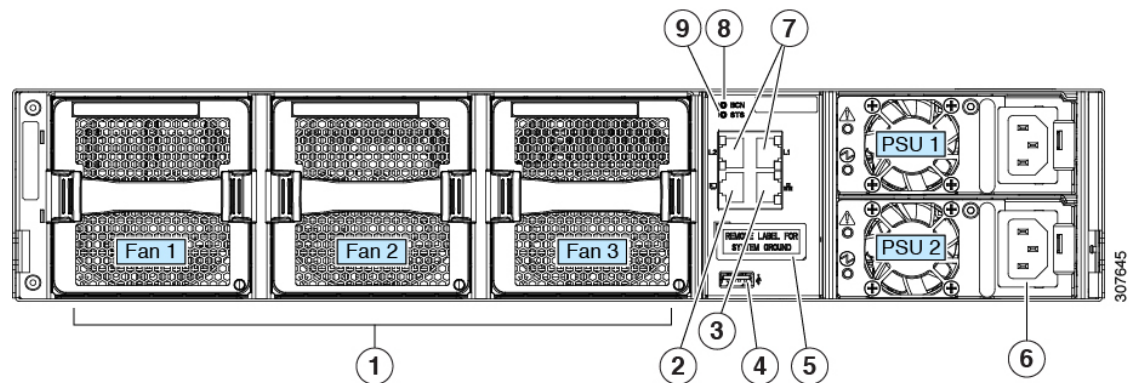

1	Cooling fans (hot swappable, 2+1 redundancy)	2	RS-232 serial console port (RJ-45 connector)
---	---	---	--

3	Network management port (RJ-45 connector)	4	USB port
5	Grounding pad for two-hole grounding lug (under protective label)	6	Power supplies Two identical AC or DC PSUs, hot-swappable, 1+1 redundancy)
7	L1/L2 high-availability ports (RJ-45 connector)	8	Beacon LED
9	System status LED		

Cisco UCS 6454 Fabric Interconnect

The Cisco UCS 6454 Fabric Interconnect (FI) is a 1-RU top-of-rack switch that mounts in a standard 19-inch rack such as the Cisco R Series rack.

The Cisco UCS 6454 Fabric Interconnect has 48 10/25 Gb SFP28 ports (16 unified ports) and 6 40/100 Gb QSFP28 ports. Each 40/100 Gb port can break out into 4 x 10/25 Gb uplink ports. The sixteen unified ports support 10/25 GbE or 8/16/32G Fibre Channel speeds.



Note The Cisco UCS 6454 Fabric Interconnect supported 8 unified ports (ports 1 - 8) with Cisco UCS Manager 4.0(1) and 4.0(2), but with release 4.0(4) and later it supports 16 unified ports (ports 1 - 16).

The Cisco UCS 6454 Fabric Interconnect supports:

- Maximum of 8 FCoE port channels
- Or 4 SAN port channels
- Or a maximum of 8 SAN port channels and FCoE port channels (4 each)

The Cisco UCS 6454 Fabric Interconnect also has one network management port, one console port for setting the initial configuration, and one USB port for saving or loading configurations. The FI also includes L1/L2 ports for connecting two fabric interconnects for high availability.

The Cisco UCS 6454 Fabric Interconnect also contains a CPU board that consists of:

- Intel Xeon D-1528 v4 Processor, 1.6 GHz
- 64 GB of RAM
- 8 MB of NVRAM (4 x NVRAM chips)
- 128 GB SSD (bootflash)

Figure 9: Cisco UCS 6454 Fabric Interconnect Rear View

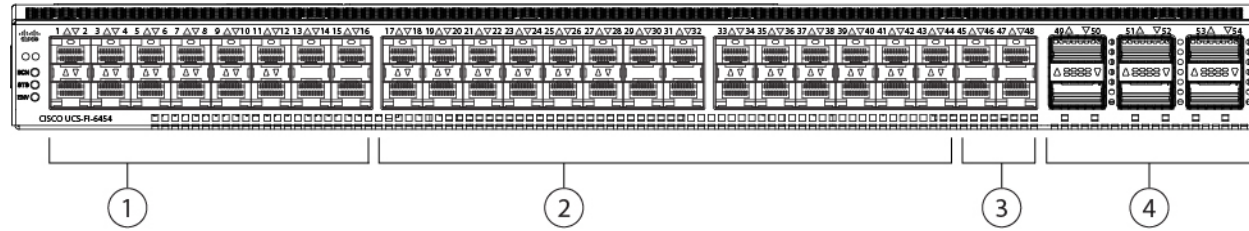

1	Ports 1-16 (Unified Ports 10/25 Gbps Ethernet or FCoE or 8/16/32 Gbps Fibre Channel) Note When using Cisco UCS Manager releases earlier than 4.0(4), only ports 1-8 are Unified Ports.	2	Ports 17-44 (10/25 Gbps Ethernet or FCoE) Note When using Cisco UCS Manager releases earlier than 4.0(4), ports 9-44 are 10/25 Gbps Ethernet or FCoE.
3	Ports 45-48 (1/10/25 Gbps Ethernet or FCoE)	4	Uplink Ports 49-54 (40/100 Gbps Ethernet or FCoE) Each of these ports can be 4 x 10/25 Gbps Ethernet or FCoE uplink ports when using an appropriate breakout cable.

The Cisco UCS 6454 Fabric Interconnect chassis has two power supplies and four fans. Two of the fans provide front to rear airflow.

Figure 10: Cisco UCS 6454 Fabric Interconnect Front View

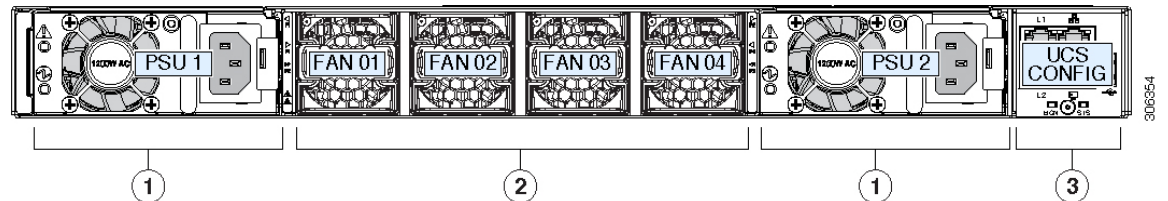

1	Power supply and power cord connector	2	Fans 1 through 4, numbered left to right, when facing the front of the chassis.
3	L1 port, L2 port, RJ45, console, USB port, and LEDs		

Ports on the Cisco UCS Fabric Interconnects

Cisco UCS Fabric Interconnect Port Overview

Cisco UCS Fabric Interconnects offer flexible and high-performance networking solutions, supporting various port configurations for Ethernet, Fibre Channel (FC), and Fibre Channel over Ethernet (FCoE) traffic. The specific capabilities vary by model and generation.

Port Details by Fabric Interconnect Model

This section details the unique port configurations and capabilities of each Cisco UCS Fabric Interconnect model.

• Cisco UCS 6652 Fabric Interconnect

Cisco UCS 6652 Fabric Interconnect features 52 ports, designed for high-density 25G/50G connectivity:

- Ports 1-16 and 33-48: supports 10/25/50 Gbps Ethernet with MACsec security.
- Ports 17-32 (Unified Ports): supports configuration of 10/25/50 Gbps Ethernet or 16/32/64 Gbps Fibre Channel (FC).
- Ports 49-52: supports 40/100/400 Gbps Ethernet with MACsec security.

• Cisco UCS 6664 Fabric Interconnect

Cisco UCS 6664 Fabric Interconnect features 64 ports, designed for flexible and high-performance networking:

- **Ports 1-24:** supports 40/100 Gbps for Ethernet, FCoE, and storage connectivity.
- **Ports 25-40 (Unified Ports):** supports configuration of 10/25/50 Gbps Ethernet or 16/32/64Gbps Fibre Channel (FC).
- **Ports 41-64:** supports configuration of 40/100 Gbps Ethernet with MACsec security (ports 49-64).

• Cisco UCS Fabric Interconnect 9108 100G (Cisco UCS X-Series Direct)

- **Ports 1 & 2:** Functions as unified ports to manage all SAN features and configurations.
- **100G Ethernet ports [1-8]:** Can be configured as 25Gx4 SFP28 compatible breakout ports or 4x10G ports, offering flexible networking solutions.
- **32G Fibre Channel ports [1 & 2] :** Can also be configured as 8Gx4 SFP28 compatible breakout ports for enhanced Fibre Channel connectivity.

• Cisco UCS 6536 Fabric Interconnect

Ports on the Cisco UCS 6536 Fabric Interconnects can be configured to carry either Ethernet or Fibre Channel traffic. You can configure only ports 33-36 to carry Fibre Channel traffic. The ports cannot be used by a Cisco UCS domain until you configure them.

• Cisco UCS 6400 Series Fabric Interconnect

Ports on the Cisco UCS 6400 Series Fabric Interconnects can be configured to carry either Ethernet or Fibre Channel traffic. The Cisco UCS 6400 Series Fabric Interconnect supported 8 unified ports (ports 1 - 8) with Cisco UCS Manager 4.0(1) and 4.0(2), but with Release 4.0(4) and later releases, it supports 16 unified ports (ports 1 - 16).

Ports 1-16 can be configured to carry Fibre Channel traffic. The ports cannot be used by a Cisco UCS domain until you configure them.

Configuration Notes

When you configure a port on a Fabric Interconnect, the administrative state is automatically set to enabled. If the port is connected to another device, this may cause traffic disruption. The port can be disabled and enabled after it has been configured.

The following table summarizes the port support the Cisco UCS Fabric Interconnects:

	Fourth Generation		Fifth Generation	Cisco UCS X-Series Direct	Sixth Generation	
Item	Cisco UCS 6454	Cisco UCS 64108	Cisco UCS 6536	Cisco UCS Fabric Interconnect 9108 100G	Cisco UCS 6664 Fabric Interconnect	Cisco UCS 6652 Fabric Interconnect
Description	54-Port Fabric Interconnect	108-Port Fabric Interconnect	36-Port Fabric Interconnect	8 Ports	64 Ports	52 Ports
Form factor	1 RU	2 RU	1 RU	1 RU	2 RU	1 RU
Number of fixed 10 GB Interfaces	48 10G/25G interfaces	96 10G/25G interfaces	36 10G/25G/40G/100G interfaces Note 144 breakout ports (36x4)	—	<ul style="list-style-type: none"> • 16x 10G/25G/50G ports • 48x 100G ports will support 10/25G using QSFP28 modules 	<ul style="list-style-type: none"> • 48 10G/25G/50G interfaces • 4x 400G ports will support 10/25G using breakout
Number of Unified Ports	16 This FI supported 8 unified ports (ports 1 - 8) with Cisco UCS Manager 4.0(1) and 4.0(2), but with Release 4.0(4) and later it supports 16 unified ports (ports 1 - 16).	16 ports 1-16	4 Note 16 breakout ports (4x4)	2 Ports 1-2	16 Ports 25-40	16 Ports 17-32
Unified Port Speeds in Gbps	10G/25G or 8G/16G/32G-FC	10G/25G or 8G/16G/32G-FC	10G/25G/40G/100G or 8G/16G/32G-FC	10G/25G/40G/100G or 8G/16G/32G-FC	10G/25G/50G or 16G/32G/64G-FC	10G/25G/50G or 16G/32G/64G-FC

	Fourth Generation		Fifth Generation	Cisco UCS X-Series Direct	Sixth Generation	
Number of 40-Gbps ports	6 40G/100G	12 40G/100G	36	—	48	4 (Ports 49-52)
Unified Port Range	Ports 1-16	Ports 1-16	Ports 33-36	Ports 1-2	Ports 25-40	Ports 17-32
Compatibility with the IOM	UCS 2408	UCS 2408	UCS 2408	—	UCS 2408	UCS 2408
Compatibility with the FEX	Cisco Nexus 93180YC-FX3	Cisco Nexus 93180YC-FX3	Cisco Nexus 93180YC-FX3	—	Cisco Nexus 93180YC-FX3	Cisco Nexus 93180YC-FX3
Compatibility with IFM	Cisco UCS 9108 25G	Cisco UCS 9108 25G	Cisco UCS 9108 25G Cisco UCS 9108 100G	Cisco UCS 9108 25G Cisco UCS 9108 100G	Cisco UCS 9108 25G Cisco UCS 9108 100G	Cisco UCS 9108 25G
Expansion Slots	None	None	None	—	None	None
Fan Modules	4	3	6	3	4	5
Power Supplies	2 (AC/DC)	2 (AC/DC)	2 (AC)	Supplied by chassis	2 (AC)	2 (AC)

Migration Limitations:

Migration from any generation Cisco UCS Fabric Interconnects (including fourth, fifth, or sixth generation) to Cisco UCS Fabric Interconnects 9108 100G (Cisco UCS X-Series Direct) is currently not supported.



CHAPTER 3

Migrating to Cisco UCS 6600 Series Fabric Interconnects

- [Cisco UCS 6600 Series Fabric Interconnect Migration, on page 23](#)

Cisco UCS 6600 Series Fabric Interconnect Migration

Migrating Cisco UCS Fabric Interconnects: 6500 to 6600 Series

Cisco UCS 6500 Series Fabric Interconnect Migration Considerations

Cisco UCS 6500 to 6652 Fabric Interconnect Migration:

Starting from Cisco UCS Manager Release 6.0(2b), you can migrate Cisco UCS 6500 Series Fabric Interconnect to Cisco UCS 6652 Fabric Interconnect with X-Series servers or C-Series rack servers.

To migrate from Cisco UCS 6500 Series Fabric Interconnect to Cisco UCS 6652 Fabric Interconnect:

- Cisco UCS 6500 Series Fabric Interconnect must be on Cisco UCS Manager 6.0(2b) or a later release versions.
- Cisco UCS 6652 Fabric Interconnect must be loaded with the same Infrastructure Firmware version that is on the Cisco UCS 6536 Fabric Interconnect that it will replace.

Cisco UCS 6500 to 6664 Fabric Interconnect Migration:

Beginning with Cisco UCS Manager, Release 6.0(1b), you can migrate Cisco UCS 6500 Series Fabric Interconnect to Cisco UCS 6664 Fabric Interconnect with X-Series servers or C-Series rack servers.

To migrate from Cisco UCS 6500 Series Fabric Interconnect to Cisco UCS 6664 Fabric Interconnect:

- Cisco UCS 6500 Series Fabric Interconnect must be on Cisco UCS Manager 6.0(1b) or a later release versions.
- Cisco UCS 6664 Fabric Interconnect must be loaded with the same Infrastructure Firmware version that is on the Cisco UCS 6536 Fabric Interconnect that it will replace.

Prerequisites

Before performing the migration from Cisco UCS 6500 Series Fabric Interconnects to Cisco UCS 6600 Series Fabric Interconnect, ensure that the following prerequisites are met for a successful migration:

- Back up and export Cisco UCS Manager configuration before initiating the upgrade.
- Take an inventory of the Cisco UCS domain and remove any unsupported hardware.
- Ensure to enable the cluster failover.
- Do not attempt to implement new software features from the new Cisco UCS software version until all required hardware is installed.
- Validate the software features and configurations between Cisco UCS 6500 series and Cisco UCS 6600 Series Fabric Interconnect. Before migration, ensure that 6500 series Fabric Interconnect is reconfigured to only have features that are supported with 6600 Series Fabric Interconnect.



Note This is one of the common reasons for migration failures.

- Make sure both Cisco UCS 6500 Series Fabric Interconnect and Cisco UCS 6600 Series Fabric Interconnect are on the same UCSM build before migration.
- Licenses from Cisco UCS 6500 Series Fabric Interconnect are not transferable to Cisco UCS 6600 Series Fabric Interconnect. Cisco UCS 6600 Series Fabric Interconnect has perpetual license enabled by default.
- Standalone installations should expect down time. In a cluster configuration, migrating the Fabric Interconnects can result in a small traffic disruption when the traffic fails over from one Fabric Interconnect to another. To avoid permanent traffic loss during migration, ensure that there is redundancy in the UCS domain on both Fabric Interconnects before migration and test the redundancy before starting the migration.
- Ensure the latest firmware bundle is downloaded and upgraded through GUI or CLI. In case of attempting to upgrade the firmware bundle using other methods (loader prompt/erase configuration) can result in missing package version.
- Before migration, make sure that the FC Speed settings on Cisco UCS Fabric Interconnects are set to operate on a mutually supported value.
 - Cisco UCS 6500 Series Fabric Interconnect supported FC speeds: 8/16/32 Gbps
 - Cisco UCS 6600 Series Fabric Interconnect supported FC speeds: 16/32/64 Gbps
- Ensure the IOM or IFM modules on both Primary and Secondary Fabric Interconnects match and are supported. Incompatible modules can result in peer communication issues.
- Make a detailed record of the cabling between FEX and fabric interconnects. You must preserve the physical port mapping to maintain the server pinning already configured and minimize down time.
- For a cluster configuration, both primary and secondary fabric interconnects must have symmetrical connection topologies between fabric interconnect and FEX.
- Ensure all cables used for connecting servers, storage, and network devices to the Fabric Interconnect support the required speeds and are compatible with fabric interconnects.
- A WWN pool in Cisco UCS can include only WWNNs or WWPNS within the ranges 20:00:00:00:00:00:00:00 to 20:FF:00:FF:FF:FF:FF:FF or 50:00:00:00:00:00:00:00 to 5F:FF:00:FF:FF:FF:FF:FF; all other WWN ranges are reserved.

When Fibre Channel traffic passes through the UCS system, the source WWPN is converted to a MAC address. Avoid configuring WWPN pools that could translate into multicast MAC addresses. To ensure uniqueness in the SAN fabric, Cisco recommends using the WWN prefix 20:00:00:25:B5:XX:XX:XX for all pool blocks.

- Enable Fabric Evacuation on the subordinate Cisco UCS 6536 Fabric Interconnect. After evacuation is complete, unconfigure all port roles and port channel configurations on the subordinate Fabric Interconnect, then configure them on the Cisco UCS 6600 Series Fabric Interconnect during migration.

Recommendations

Following are the best practices for a successful migration:

- For minimal disruption during migration, ensure that there is redundancy for Ethernet and FC traffic from the servers in the UCS domain across both Cisco UCS 6500 Series Fabric Interconnect before migration.
- Changes to the topology, such as the number of servers or uplink connections, should be performed after the fabric interconnect migration is complete.
- During the migration of Fabric Interconnects, ensure the Cluster ID is not changed.
- Image synchronization between Fabric Interconnects is disabled during migration to avoid syncing incompatible images. Once migration is complete, download and reinstall the appropriate server software bundles.
- During the migration, ensure that VLAN is not created in the range of 3915 to 4042 which are the reserved VLAN range for Cisco UCS 6600 Series Fabric Interconnects.



Note For more information on migrating Cisco UCS 6500 series Fabric Interconnects to Cisco UCS 6600 series Fabric Interconnect with UCS Central, see [Considerations for migrating Cisco UCS 6536 Fabric Interconnect to Cisco UCS 6600 Series Fabric Interconnect with Cisco UCS Central](#).

Validating Feature Configurations for Cisco UCS 6600 Series Fabric Interconnect before Upgrade

Cisco UCS 6600 Series Fabric Interconnect does not support some software features that were allowed with Cisco UCS 6536 Fabric Interconnect. Some of these features will become available at a later software release.

Table 3: Features that needs special attention prior to upgrading

Feature	Remediation
License Management	Cisco UCS 6536 Fabric Interconnect and Cisco UCS 6600 Series Fabric Interconnect requires perpetual software license. All ports and software features are activated through a perpetual software license. No additional license management is required.
Multicast optimization	Verify that multicast optimization is not enabled under the LAN quality-of-service (QoS) system classes

Feature	Remediation
Fabric forwarding mode for Ethernet	Verify that the Ethernet forwarding mode is set to End Host Mode Only .
Fabric forwarding mode for Fibre Channel	Verify that Fibre Channel forwarding mode is set to End Host Mode or FC Switching Mode .
Cisco NetFlow	Unconfigure NetFlow.
MAC Security	Select Allow for MAC security.
Cisco Switched Port Analyzer (SPAN)	Use receive (RX) direction only. The installer will change SPAN to the RX direction and send an alert indicating that this setting is being changed.

Failure to comply with these remediation steps will result in a migration warning alert during the migration process and prevent the fabric interconnects from synchronizing.

Considerations for migrating Cisco UCS 6536 Fabric Interconnect to Cisco UCS 6600 Series Fabric Interconnect with Cisco UCS Central

In addition to [Cisco UCS 6500 Series Fabric Interconnect Migration Considerations, on page 23](#), consider the following prerequisites when migrating with Cisco UCS Central:

- Before initiating the migration, ensure to have a complete backup of Cisco UCS Manager and UCS Central configurations.
- To avoid any configuration issues during migration, make sure the following policies on Policy Resolution Control is set to Local in Cisco UCS Manager:
 - Infrastructure and Catalog Firmware Policy
 - Equipment Policy
 - Port Configuration Policy

Migrating from Cisco UCS 6536 Fabric Interconnect to Cisco UCS 6600 Series Fabric Interconnect

Cisco UCS 6500 Series Fabric Interconnect include Cisco UCS 6536 Fabric Interconnect and Cisco UCS 6600 Series Fabric Interconnect include Cisco UCS 6664 Fabric Interconnect and Cisco UCS 6652 Fabric Interconnect.

You can migrate from Cisco UCS 6536 Fabric Interconnect to Cisco UCS 6600 Series Fabric Interconnect. After migrating to Cisco UCS 6600 Series Fabric Interconnect, Cisco recommends not to migrate back to Cisco UCS 6536 Fabric Interconnect.

The Cisco UCS 6600 Series Fabric Interconnect supports only port-channel mode for chassis-discovery. On changing the chassis or FEX discovery policy to port-channel, the chassis needs to be re-acknowledged before proceeding with the migration.

To acknowledge the chassis in Cisco UCS Manager, do the following:

1. In the Navigation pane of Cisco UCS Manager, click **Equipment**.
2. Click the **Equipment** node.

3. In the Work pane, click the **Policies** tab.
4. Click the **Global Policies** subtab.
5. Expand **Equipment** > **Chassis**, and choose the chassis that you want to acknowledge.
6. In the Work pane, click the **General** tab.
7. In the **Actions** area, click **Acknowledge Chassis**.



Note For more information about how to perform configuration procedures in Cisco UCS Manager, see the appropriate [Cisco UCS Manager Configuration Guide](#).

Procedure

- Step 1** Move the traffic to the primary fabric interconnect. This can be performed in two ways: fabric evacuation and uplink disablement. Use the below flowchart to choose between the two based on your Cisco UCS domain server and

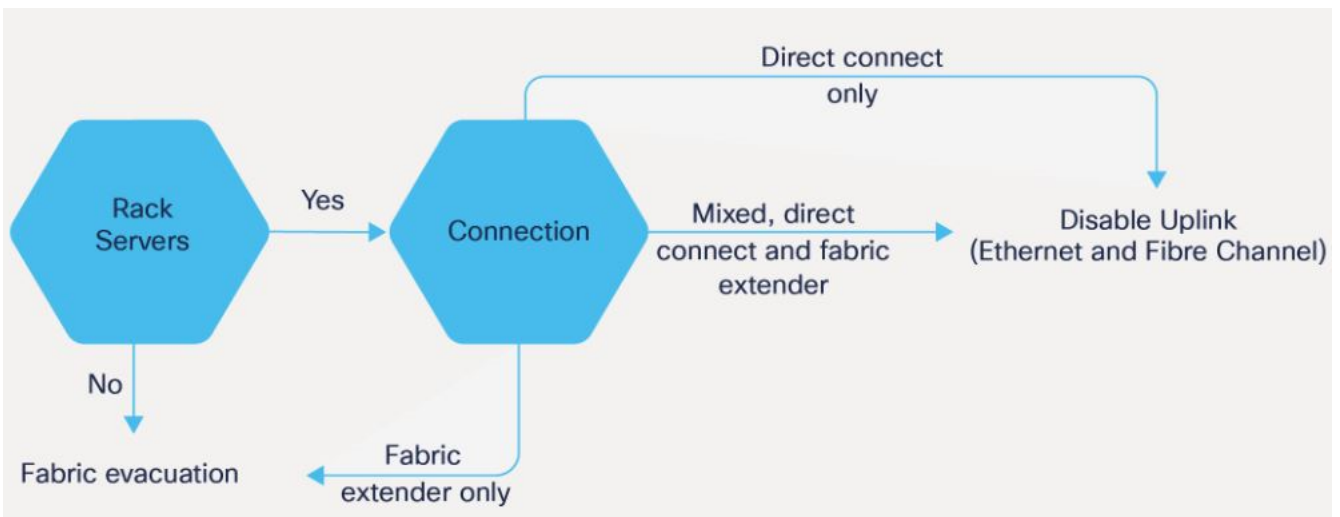

Note

For direct-attached rack servers, only uplink disablement is supported.

- Step 2** Verify that all traffic has failed over to the primary fabric interconnect. Unconfigure all server ports or fibre channel ports on the subordinate fabric interconnect.
- For more information, see the *Fabric Interconnect Traffic Evacuation* section in the *Guidelines and Prerequisites* chapter of the [Firmware Management Guide](#).
- Step 3** Power down the old subordinate fabric interconnect and disconnect the power and the L1/L2 cables.
- If you are monitoring the migration using a KVM session to a server host, you may need to reconnect it after you powered down the secondary fabric interconnect.

- Step 4** Mount the replacement Cisco UCS 6600 Series Fabric Interconnect into either the same rack or an adjacent rack.
- Note**
It is recommended to label cables as a best practice.
- Step 5** Connect the L1/L2 cables and the server ports according to your port mapping plan.
- Step 6** Power up the new fabric interconnect. If it is connected correctly, the new subordinate fabric interconnect will detect that it is being added to an existing cluster.
- Step 7** The subordinate Cisco UCS 6600 Series Fabric Interconnect will automatically synchronize the configuration and database/state information from the primary Cisco UCS 6536 Fabric Interconnect.
- Synchronization between primary and subordinate fabric interconnects can take several minutes. You may see an error message that will persist until the server ports are enabled.
- The port configuration is copied from the subordinate Fabric Interconnect to the new Fabric Interconnect.
- Note**
Skip to Step 10 in case of replacing with a different IOM, IFM, or FEX during migration. For more information on the compatibility matrix of supported IOM, IFM, or FEX on the Fabric Interconnect, see [Ports on the Cisco UCS Fabric Interconnects](#), on page 19.
- Step 8** Unified ports on the Cisco UCS 6600 Series Fabric Interconnect are different from the unified port ordering on the Cisco UCS 6536 Fabric Interconnect.
- Note**
- When you convert from ethernet ports to fibre channel ports, a reboot is required. Fibre channel ports are converted in blocks of four (breakout ports).
 - For more information on *Configuring FC Uplink port* or *Converting FC storage port to FC uplink port*, see the *LAN Ports and Port Channels* chapter in [Network Management Guide](#).
- Step 9** Configure the network uplink ports on the new Cisco UCS 6600 Series Fabric Interconnect
- Step 10** Match the old configuration from Cisco UCS 6500 Series Fabric Interconnect for the port-channel. Add uplink ports to the necessary port-channel or any other previous configuration required for the port-channel. Wait for configuration to complete before proceeding to the next step.
- Note**
Waiting to enable the server ports prevents the svc_sam_bladeAG service from communicating with chassis and servers. In previous migrations, when enabling server ports at the same time as the uplink ports, it would cause topping out (pinning) the CPU to near 100% on the primary fabric interconnect. When there is high CPU usage, the user interface becomes unresponsive and the svc_sam_bladeAG service must be restarted to recover.
- Step 11** Reconfigure the server ports or fibre channel ports.
- a) If you have changed port mappings, you may need to reacknowledge the IOM, FEX, or direct-connect rack server connected to the subordinate fabric interconnect.
 - b) Verify and if necessary, you can reconfigure ethernet ports as server ports.
 - c) Skip to Step 13 to verify the data path.
- Step 12** To remove and replace the new IOM, IFM, or FEX and reconfigure the server ports, do the following:

- a) Remove the existing module connected to the subordinate Fabric Interconnect and replace it with a supported module of Cisco UCS 6600 Series Fabric Interconnect.
- b) Verify if cable connections require modifications.

Note

If the current Fabric Interconnect configuration includes the FEX (Cisco Nexus 93180YC-FX3 (100G)), ensure that its connection to the Cisco UCS 6652 Fabric Interconnect uses breakout cables, with the breakout ends connected to the Fabric Interconnect.

- c) Reconfigure to maintain the same port mappings. If not preserved, configure server ports accordingly.
- d) Reacknowledge the IOM, FEX, or IFM connected to the subordinate Fabric Interconnect.

Step 13 Verify that the data path is ready.

For more information, see the *Verifying that Dynamic vNICs Are Up and Running* section in the *Guidelines and Prerequisites* chapter of the [Cisco UCS Manager Firmware Management](#).

Ensure that all faults are resolved before proceeding with next step.

- a) Verify, and if necessary, reconfigure the SAN pin group for fibre channel ports in the associated service profile.
- b) Verify, and if necessary, reconfigure the LAN pin group for ethernet ports in the associated service profile.
- c) Verify, and if necessary, reconfigure the port channel for uplink ethernet ports.

Step 14 Move the traffic back to the new subordinate fabric interconnect. If you used the fabric evacuation method, then deselect fabric evacuation. If you disabled the uplinks (Ethernet and Fibre Channel), then re-enable the uplinks. Verify that traffic is flowing correctly on the new subordinate fabric interconnect.

Step 15 After verifying that traffic is flowing on the subordinate fabric interconnect, promote the subordinate fabric interconnect to primary using the below commands:

- UCS-A #connect local-mgmt: This command connects to the local management interface of the cluster.
- UCS-A (local-mgmt) #cluster{lead {a|b}} or UCS-A (local-mgmt) #cluster{force primary {a|b}}: The cluster lead command and cluster force primary command are two separate commands that can be used for promoting the fabric interconnect.

Note

Ensure that the primary fabric interconnect is Cisco UCS 6600 Series Fabric Interconnect.

Step 16 Cable the second new fabric interconnect identically to the first and repeat the steps for the other fabric interconnect replacements to complete the migration.

Migrating Cisco UCS Fabric Interconnects: 6400 to 6600 Series

Considerations for Migrating Cisco UCS 6400 Series Fabric Interconnects

Cisco UCS Manager supports migration from Cisco UCS 6400 Series Fabric Interconnects (Cisco UCS 6454 or Cisco UCS 64108) to Cisco UCS 6600 Series Fabric Interconnects (Cisco UCS 6664 or Cisco UCS 6652). The Cisco UCS 6400 Series Fabric Interconnects must be running a UCS Manager release that supports migration to the Cisco UCS 6600 Series.

During migration, ensure that the Cisco UCS 6600 Series Fabric Interconnects are loaded with the same Infrastructure Firmware version as the Cisco UCS 6400 Series Fabric Interconnects being replaced. This ensures compatibility and a smooth migration process.

Prerequisites

Before performing the migration from Cisco UCS 6400 Series Fabric Interconnects to Cisco UCS 6600 Series Fabric Interconnect, ensure that the following prerequisites are met for a successful migration:

- Back up and export Cisco UCS Manager configuration before initiating the upgrade.
- Take an inventory of the Cisco UCS domain and remove any unsupported hardware.
- Ensure to enable the cluster failover.
- Do not attempt to implement new software features from the new Cisco UCS software version until all required hardware is installed.
- Validate the software features and configurations between Cisco UCS 6400 series and Cisco UCS 6600 Series Fabric Interconnect. Before migration, ensure that 6400 series Fabric Interconnect is reconfigured to only have features that are supported with 6600 Series Fabric Interconnect.



Note This is one of the common reasons for migration failures.

- Make sure both Cisco UCS 6400 series Fabric Interconnect and Cisco UCS 6600 Series Fabric Interconnect are on the same UCSM build before migration.
- Licenses from Cisco UCS 6400 Series Fabric Interconnects are not transferable to Cisco UCS 6600 Series Fabric Interconnect. Cisco UCS 6600 Series Fabric Interconnect has perpetual license enabled by default.
- Standalone installations should expect down time. In a cluster configuration, migrating the Fabric Interconnects can result in a small traffic disruption when the traffic fails over from one Fabric Interconnect to another. To avoid permanent traffic loss during migration, ensure that there is redundancy in the UCS domain on both Fabric Interconnects before migration and test the redundancy before starting the migration.
- Ensure the latest firmware bundle is downloaded and upgraded through GUI or CLI. In case of attempting to upgrade the firmware bundle using other methods (loader prompt/erase configuration) can result in missing package version.
- Before migration, make sure that the FC Speed settings on Cisco UCS Fabric Interconnects are set to operate on a mutually supported value.
 - Cisco UCS 6400 Series Fabric Interconnect supported FC speeds: 8/16 Gbps
 - Cisco UCS 6600 Series Fabric Interconnect supported FC speeds: 16/32/64 Gbps
- Ensure the IOM or IFM modules on both Primary and Secondary Fabric Interconnects match and are supported. Incompatible modules can result in peer communication issues.
- Make a detailed record of the cabling between FEX and fabric interconnects. You must preserve the physical port mapping to maintain the server pinning already configured and minimize down time.
- For a cluster configuration, both primary and secondary fabric interconnects must have symmetrical connection topologies between fabric interconnect and FEX.

- Ensure all cables used for connecting servers, storage, and network devices to the Fabric Interconnect support the required speeds and are compatible with fabric interconnects.
- A WWN pool in Cisco UCS can include only WWNNs or WWPNS within the ranges 20:00:00:00:00:00:00:00 to 20:FF:00:FF:FF:FF:FF:FF or 50:00:00:00:00:00:00:00 to 5F:FF:00:FF:FF:FF:FF:FF; all other WWN ranges are reserved.

When Fibre Channel traffic passes through the UCS system, the source WWPN is converted to a MAC address. Avoid configuring WWPNS pools that could translate into multicast MAC addresses. To ensure uniqueness in the SAN fabric, Cisco recommends using the WWN prefix 20:00:00:25:B5:XX:XX:XX for all pool blocks.

- Enable Fabric Evacuation on the subordinate Cisco UCS 6400 Series Fabric Interconnect. After evacuation is complete, unconfigure all port roles and port channel configurations on the subordinate Fabric Interconnect, then configure them on the Cisco UCS 6600 Series Fabric Interconnect during migration.

Recommendations

Following are the best practices for a successful migration:

- For minimal disruption during migration, ensure that there is redundancy for Ethernet and FC traffic from the servers in the UCS domain across both 6400 series fabric interconnects before migration.
- Changes to the topology, such as the number of servers or uplink connections, should be performed after the fabric interconnect migration is complete.
- During the migration of Fabric Interconnects, ensure the Cluster ID is not changed.
- Image synchronization between Fabric Interconnects is disabled during migration to avoid syncing incompatible images. Once migration is complete, download and reinstall the appropriate server software bundles.
- During the migration, ensure that VLAN is not created in the range of 3915 to 4042 which are the reserved VLAN range for Cisco UCS 6600 Series Fabric Interconnects.



Note For more information on migrating Cisco UCS 6400 series Fabric Interconnects to Cisco UCS 6600 series Fabric Interconnect with UCS Central, see [Considerations for migrating Cisco UCS 6400 Series Fabric Interconnects to UCS 6664 Fabric Interconnects with Cisco UCS Central](#), on page 32.

Validating Feature Configurations for Cisco UCS 6664 before Upgrade

Cisco UCS 6664 Fabric Interconnect does not support some software features that were supported with Cisco UCS 6400 Series Fabric Interconnect.

Table 4: Features that needs special attention prior to upgrading

Feature	Remediation
License Management	Licensing for Cisco UCS 6664 Fabric Interconnect is not a port-based license like in previous generation Fabric Interconnects. All ports and software features are activated through a perpetual software license. No additional license management is required.
Multicast optimization	Verify that multicast optimization is not enabled under the LAN quality-of-service (QoS) system classes
Fabric forwarding mode for Ethernet	Verify that the Ethernet forwarding mode is set to End Host Mode Only .
Fabric forwarding mode for Fibre Channel	Verify that Fibre Channel forwarding mode is set to End Host Mode or FC Switching Mode .
Cisco NetFlow	Unconfigure NetFlow.
MAC Security	Select Allow for MAC security.
VM-FEX	Remove port profiles and Cisco UCS Manager ESXi or SCVMM related configurations.
Dynamic vNIC Connection policies	Set the dynamic vNIC connection policy in the vNIC profile to Not Set .
Cisco Switched Port Analyzer (SPAN)	Use receive (RX) direction only. The installer will change SPAN to the RX direction and send an alert indicating that this setting is being changed.

Failure to comply with these remediation steps will result in a migration warning alert during the migration process and prevent the fabric interconnects from synchronizing.

Considerations for migrating Cisco UCS 6400 Series Fabric Interconnects to UCS 6664 Fabric Interconnects with Cisco UCS Central

In addition to [Considerations for Migrating Cisco UCS 6400 Series Fabric Interconnects, on page 29](#), consider the following prerequisites when migrating with Cisco UCS Central:

- Before initiating the migration, ensure to have a complete backup of Cisco UCS Manager and UCS Central configurations.
- To avoid any configuration issues during migration, make sure the following policies on Policy Resolution Control is set to Local in Cisco UCS Manager:
 - Infrastructure and Catalog Firmware Policy
 - Equipment Policy
 - Port Configuration Policy

Migrating from UCS 6400 Series Fabric Interconnects to Cisco UCS 6600 Series Fabric Interconnects

Beginning with Cisco UCS Manager, Release 6.0(2b), you can migrate Cisco UCS 6400 Series Fabric Interconnects (Cisco UCS 6454 and Cisco UCS 64108 Fabric Interconnects) to Cisco UCS 6600 Series Fabric Interconnect (Cisco UCS 6664 and Cisco UCS 6652 Fabric Interconnects).

Beginning with Cisco UCS Manager, Release 6.0(1), you can migrate Cisco UCS 6400 Series Fabric Interconnects (Cisco UCS 6454 and Cisco UCS 64108 Fabric Interconnects) to Cisco UCS 6600 Series Fabric Interconnect (Cisco UCS 6664 Fabric Interconnect).

After migrating to Cisco UCS 6600 Series Fabric Interconnect, Cisco recommends not to migrate back to UCS 6400 Series Fabric Interconnect.

The Cisco UCS 6600 Series Fabric Interconnect supports only port-channel mode for chassis-discovery. On changing the chassis or FEX discovery policy to port-channel, the chassis needs to be re-acknowledged before proceeding with the migration.

To acknowledge the chassis in Cisco UCS Manager, do the following:

1. In the Navigation pane of Cisco UCS Manager, click **Equipment**.
2. Click the **Equipment** node.
3. In the Work pane, click the **Policies** tab.
4. Click the **Global Policies** subtab.
5. Expand **Equipment > Chassis**, and choose the chassis that you want to acknowledge.
6. In the Work pane, click the **General** tab.
7. In the **Actions** area, click **Acknowledge Chassis**.



Note For more information about how to perform configuration procedures in Cisco UCS Manager, see the appropriate [Cisco UCS Manager Configuration Guide](#).

Procedure

-
- Step 1** Move the traffic to the primary fabric interconnect. This can be performed in two ways: fabric evacuation and uplink disablement. Use the below flowchart to choose between the two based on your Cisco UCS domain

server and

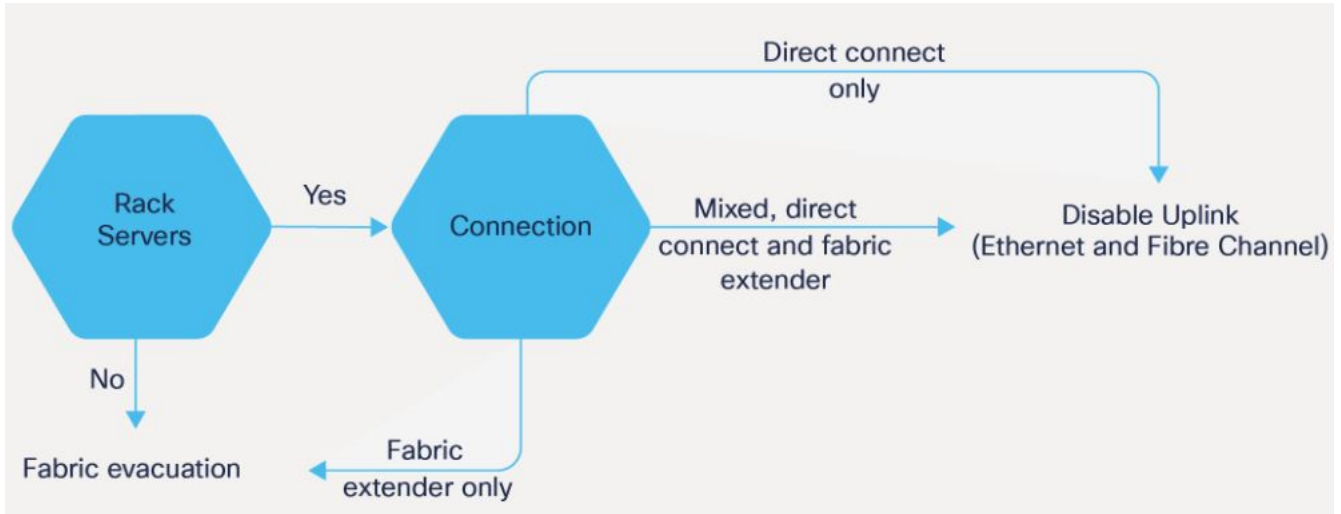

Note

For direct-attached rack servers, only uplink disablement is supported.

- Step 2** Verify that all traffic has failed over to the primary fabric interconnect. Unconfigure all server ports or fibre channel ports on the subordinate fabric interconnect.

For more information, see the *Fabric Interconnect Traffic Evacuation* section in the *Guidelines and Prerequisites* chapter of the [Cisco UCS Manager Firmware Management Guide](#).

- Step 3** Power down the old subordinate fabric interconnect and disconnect the power and the L1/L2 cables.
If you are monitoring the migration using a KVM session to a server host, you may need to reconnect it after you powered down the secondary fabric interconnect.

- Step 4** Mount the replacement Cisco UCS 6600 Series Fabric Interconnect into either the same rack or an adjacent rack.

Note

It is recommended to label cables as a best practice.

- Step 5** Connect the L1/L2 cables and the server ports according to your port mapping plan.

- Step 6** Power up the new fabric interconnect. If it is connected correctly, the new subordinate fabric interconnect will detect that it is being added to an existing cluster.

- Step 7** The subordinate Cisco UCS 6600 Series Fabric Interconnect will automatically synchronize the configuration and database/state information from the primary UCS 6400 Series Fabric Interconnect.

Synchronization may take several minutes. Error messages may persist until server ports are enabled.

The port configuration is copied from the subordinate Fabric Interconnect to the new Fabric Interconnect.

Note

Skip to Step 10 in case of replacing with a different IOM, IFM, or FEX during migration. For more information on the compatibility matrix of supported IOM, IFM, or FEX on the Fabric Interconnect, see [Ports on the Cisco UCS Fabric Interconnects, on page 19](#).

- Step 8** Unified ports on the Cisco UCS 6600 Series Fabric Interconnect are different from the unified port ordering on the 6400 series Fabric Interconnect.
- Note**
- When you convert from ethernet ports to fibre channel ports, a reboot is required. Fibre channel ports are converted in blocks of four (breakout ports).
 - For more information on *Configuring FC Uplink port* or *Converting FC storage port to FC uplink port*, see the *LAN Ports and Port Channels* chapter in [Cisco UCS Manager Network Management Guide](#).
- Step 9** Configure the network uplink ports on the new Cisco UCS 6664 Fabric Interconnect
- Step 10** Match the old configuration from Cisco UCS 6400 Fabric Interconnect for the port-channel. Add uplink ports to the necessary port-channel or any other previous configuration required for the port-channel. Wait for configuration to complete before proceeding to the next step.
- Note**
- Waiting to enable the server ports prevents the svc_sam_bladeAG service from communicating with chassis and servers. In previous migrations, when enabling server ports at the same time as the uplink ports, it would cause topping out (pinning) the CPU to near 100% on the primary fabric interconnect. When there is high CPU usage, the user interface becomes unresponsive and the svc_sam_bladeAG service must be restarted to recover.
- Step 11** Reconfigure the server ports or fibre channel ports.
- a) If you have changed port mappings, you may need to reacknowledge the IOM, FEX, or direct-connect rack server connected to the subordinate fabric interconnect.
 - b) Verify and if necessary, you can reconfigure ethernet ports as server ports.
 - c) Skip to Step 13 to verify the data path.
- Step 12** To remove and replace the new IOM, FEX, or IFM and reconfigure the server ports, do the following:
- a) Remove the existing module connected to the subordinate Fabric Interconnect and replace it with a supported module of Cisco UCS 6600 Series Fabric Interconnect.
 - b) Verify if cable connections require modifications.
 - c) Reconfigure to maintain the same port mappings. If not preserved, configure server ports accordingly.
 - d) Reacknowledge the IOM, FEX, or IFM connected to the subordinate Fabric Interconnect.
- Step 13** Verify that the data path is ready.
- For more information, see the *Verifying that Dynamic vNICs Are Up and Running* section in the *Guidelines and Prerequisites* chapter of the [Cisco UCS Manager Firmware Management Guide](#).
- Ensure that all faults are resolved before proceeding with next step.
- a) Verify, and if necessary, reconfigure the SAN pin group for fibre channel ports in the associated service profile.
 - b) Verify, and if necessary, reconfigure the LAN pin group for ethernet ports in the associated service profile.
 - c) Verify, and if necessary, reconfigure the port channel for uplink ethernet ports.
- Step 14** Move the traffic back to the new subordinate fabric interconnect. If you used the fabric evacuation method, then deselect fabric evacuation. If you disabled the uplinks (Ethernet and Fibre Channel), then re-enable the uplinks. Verify that traffic is flowing correctly on the new subordinate fabric interconnect.
- Step 15** After verifying that traffic is flowing on the subordinate fabric interconnect, promote the subordinate fabric interconnect to primary using the below commands:

- UCS-A `#connect local-mgmt`: This command connects to the local management interface of the cluster.
- UCS-A (local-mgmt) `#cluster{lead {a|b}}` or UCS-A (local-mgmt) `#cluster{force primary {a|b}}`: The cluster lead command and cluster force primary command are two separate commands that can be used for promoting the fabric interconnect.

Note

Ensure that the primary fabric interconnect is Cisco UCS 6600 Series Fabric Interconnect.

Step 16

Cable the second new fabric interconnect identically to the first and repeat the steps for the other fabric interconnect replacements to complete the migration.



CHAPTER 4

Migrating to Cisco UCS 6500 Series Fabric Interconnects

- [Cisco UCS 6400 Series Fabric Interconnect Migration, on page 37](#)

Cisco UCS 6400 Series Fabric Interconnect Migration

Cisco UCS 6400 Series Fabric Interconnect Migration Considerations

Beginning with Cisco UCS Manager, Release 4.3(2b), You can migrate Cisco UCS 6400 Series Fabric Interconnects to Cisco UCS 6536 Fabric Interconnect with B-Series servers, C-Series, or S-Series servers.

To migrate from Cisco UCS 6400 Series Fabric Interconnects to Cisco UCS 6536 Fabric Interconnect:

- Cisco UCS 6400 Series Fabric Interconnects must be on Cisco UCS Manager 4.3(2b) or a later release.
- Cisco UCS 6536 Fabric Interconnect must be loaded with the same Infrastructure Firmware version that is on the Cisco UCS 6400 Series Fabric Interconnect that it will replace.

Prerequisites

Before performing the migration from Cisco UCS 6400 Series Fabric Interconnects to Cisco UCS 6536 Fabric Interconnect, ensure that the following prerequisites are met for a successful migration:

- Back up and export Cisco UCS Manager configuration before initiating the upgrade.
- Take an inventory of the Cisco UCS domain and remove any unsupported hardware.
- Ensure to enable the cluster failover.
- Do not attempt to implement new software features from the new Cisco UCS software version until all required hardware is installed.
- Validate the software features and configurations between Cisco UCS 6400 series and UCS 6536 Fabric Interconnects. Before migration, ensure that 6400 series Fabric Interconnect is reconfigured to only have features that are supported with 6536 Fabric Interconnects.



Note This is one of the most common reasons for migration failures.

- Make sure both Cisco UCS 6400 series and 6500 series Fabric Interconnects are on the same UCSM build before migration.
- Licenses from Cisco UCS 6400 Series Fabric Interconnects are not transferable to Cisco UCS 6500 Series Fabric Interconnects. Cisco UCS 6500 Series Fabric Interconnects has perpetual license enabled by default.
- Standalone installations should expect down time. In a cluster configuration, migrating the Fabric Interconnects can result in a small traffic disruption when the traffic fails over from one Fabric Interconnect to another. To avoid that there is no permanent traffic loss during migration, ensure that there is redundancy in the UCS domain on both Fabric Interconnects before migration and test the redundancy before starting the migration.
- Cisco UCS 6536 Fabric Interconnect use the IDLE fill pattern for FC uplink ports and FC storage ports when using 8 Gbps speed.

When migrating to Cisco UCS 6536 Fabric Interconnect and configuring FC Uplink Ports or FC Storage Ports at 8Gbps speed, ensure that the fill pattern is set as IDLE on the corresponding FC switch ports and the direct-attached FC storage array ports. If the fill pattern is not set as IDLE, FC uplink ports and FC storage ports operating at 8 Gbps might go to an errDisabled state, lose SYNC intermittently, or receive errors or bad packets.

Cisco UCS 6536 Fabric Interconnects supports 8 Gbps only with fill-pattern set to IDLE for direct-attached FC connectivity (FC uplink ports or FC storage ports). This limitation is not applicable for Cisco UCS 6536 Fabric Interconnects with Fibre Channel (FC) ports at 16 Gbps and 32 Gbps. When migrating to Cisco UCS 6536 Fabric Interconnect for direct-attached storage arrays that don't support IDLE fill-pattern at 8 Gbps do one of the following:

- Use a SAN switch between the Cisco UCS 6536 Fabric Interconnect and the storage array with 8 GB FC connectivity.
- Upgrade the storage array to 16 GB or 32 GB FC connectivity.
- Ensure the latest firmware bundle is downloaded and upgraded through GUI or CLI. In case of attempting to upgrade the firmware bundle using other methods (loader prompt/erase configuration) can result in missing package version.
- Before migration, make sure that the FC Speed is 8Gbps on Cisco UCS 6400 Fabric Interconnects or the connected switch supports 8Gbps speed.



Note Post migration, you can configure the FC Port (Scalability Port) speed on Cisco UCS 6500 Fabric Interconnects.

- Migrating to different IOM models can result in peer communication issue between IOMs of the Primary and Secondary Fabric Interconnects.
- Make a detailed record of the cabling between FEX and fabric interconnects. You must preserve the physical port mapping to maintain the server pinning already configured and minimize down time.
- For a cluster configuration, both fabric interconnects must have symmetrical connection topologies between fabric interconnect and FEX.

- Use the same speed cables on all the adapter ports that are connected to same Fabric Interconnect. Cisco UCS VIC adapter ports connected to Cisco UCS 6536 fabric interconnect through a mix of 10G and 25G cables can result in UCS rack-mount server discovery failure and ports moving to suspended state.
- Cisco UCS 6536 Fabric Interconnect only supports 25/40/100G direct connectivity for C-series rack servers and 10G direct-connect is not supported on C-series rack servers. The Cisco UCS 6536 Fabric Interconnect supports 10G server connectivity only with 2348-UPQ FEX.
- A WWN pool can include only WWNNs or WWPNS in the ranges from 20:00:00:00:00:00:00 to 20:FF:00:FF:FF:FF:FF or from 50:00:00:00:00:00:00 to 5F:FF:00:FF:FF:FF:FF. All other WWN ranges are reserved. When fibre channel traffic is sent through the UCS infrastructure the source WWPNS is converted to a MAC address. You cannot use WWPNS pool which can translate to source multicast MAC addresses. To ensure the uniqueness of the Cisco UCS WWNNs and WWPNS in the SAN fabric, Cisco recommends using the following WWN prefix for all blocks in a pool:
20:00:00:25:B5:XX:XX:XX
- Unconfigure the fibre channel ports on the migrating subordinate Cisco UCS 6400 series Fabric Interconnect and reconfigure on the Cisco UCS 6536 Fabric Interconnect.

Recommendations

Following are the best practices for a successful migration:

- For minimal disruption during migration, ensure that there is redundancy for Ethernet and FC traffic from the servers in the UCS domain across both 6400 series fabric interconnects before migration.
- Changes to the topology, such as the number of servers or uplink connections, should be performed after the fabric interconnect migration is complete.
- During the migration of Fabric Interconnects, ensure the Cluster ID is not changed.
- During the migration, image synchronization between fabric interconnects is not allowed. This is done to prevent incompatible images from getting synchronized. It is necessary to download B-Series, C-Series, and S-Series server software bundles again after migration is complete.
- During the migration, ensure that VLAN is not created in the range of 3915 to 4042 which are the reserved VLAN range for Cisco UCS 6536 Fabric Interconnects.
- The Cisco UCS 6536 Fabric Interconnect supports only port-channel mode for chassis-discovery. Hence, before starting migration, change the chassis/FEX discovery policy on the Cisco UCS 6400 series Fabric Interconnect to port-channel and immediately re-acknowledge the chassis.



Note The migration can fail when the chassis is not immediately re-acknowledged.



Note For more information on migrating Cisco UCS 6400 series Fabric Interconnects to Cisco UCS 6500 series Fabric Interconnect with UCS Central, see [Considerations for migrating Cisco UCS 6400 Series Fabric Interconnects to Cisco UCS 6500 Series Fabric Interconnects with Cisco UCS Central](#), on page 40.

Validating Feature Configurations for Cisco UCS 6536 before Upgrade

Cisco UCS 6536 Fabric Interconnect does not support some software features that were allowed with Cisco UCS 6400 Series Fabric Interconnect. Some of these features will become available at a later software release.

Table 5: Features that needs special attention prior to upgrading

Feature	Remediation
License Management	Licensing for Cisco UCS 6536 Fabric Interconnect is not a port-based license like in previous generation Fabric Interconnects. All ports are enabled through a perpetual license in Cisco UCS 6536 Fabric Interconnect and no license installation is required.
Chassis and fabric extender I/O port channel	Select a port channel to the I/O module (IOM).
Multicast optimization	Verify that multicast optimization is not enabled under the LAN quality-of-service (QoS) system classes
Fabric forwarding mode for Ethernet	Verify that the Ethernet forwarding mode is set to End Host Mode Only .
Fabric forwarding mode for Fibre Channel	Verify that Fibre Channel forwarding mode is set to End Host Mode or FC Switching Mode .
Cisco NetFlow	Unconfigure NetFlow.
MAC Security	Select Allow for MAC security.
VM-FEX	Remove port profiles and Cisco UCS Manager ESXi or SCVMM related configurations.
Dynamic vNIC connection policies	Set the dynamic vNIC connection policy in the vNIC profile to Not set .
Cisco Switched Port Analyzer (SPAN)	Use receive (RX) direction only. The installer will change SPAN to the RX direction and send an alert indicating that this setting is being changed.

Failure to comply with these remediation steps will result in a migration warning alert during the migration process and prevent the fabric interconnects from synchronizing.

Considerations for migrating Cisco UCS 6400 Series Fabric Interconnects to Cisco UCS 6500 Series Fabric Interconnects with Cisco UCS Central

In addition to [Cisco UCS 6400 Series Fabric Interconnect Migration Considerations, on page 37](#), consider the following prerequisites when migrating with Cisco UCS Central:

- Before initiating the migration, ensure to have a complete backup of Cisco UCS Manager and UCS Central configurations.

- To avoid any configuration issues during migration, make sure the following policies on Policy Resolution Control is set to Local in Cisco UCS Manager:
 - Infrastructure and Catalog Firmware Policy
 - Equipment Policy
 - Port Configuration Policy

Migrating from UCS 6400 Series Fabric Interconnects to UCS 6536 Fabric Interconnects

Cisco UCS 6400 Series Fabric Interconnects include Cisco UCS 6454 and Cisco UCS 64108. You can migrate from Cisco UCS 6400 Series Fabric Interconnects to Cisco UCS 6536 Fabric Interconnect. After migrating to Cisco UCS 6536 Fabric Interconnect, Cisco recommends not to migrate back to UCS 6400 Series Fabric Interconnect.

The Cisco UCS 6536 Fabric Interconnect supports only port-channel mode for chassis-discovery. On changing the chassis or FEX discovery policy to port-channel, the chassis needs to be re-acknowledged before proceeding with the migration.

To acknowledge the chassis in Cisco UCS Manager, do the following:

1. In the Navigation pane of Cisco UCS Manager, click **Equipment**.
2. Click the **Equipment** node.
3. In the Work pane, click the **Policies** tab.
4. Click the **Global Policies** subtab.
5. Expand **Equipment > Chassis**, and choose the chassis that you want to acknowledge.
6. In the Work pane, click the **General** tab.
7. In the **Actions** area, click **Acknowledge Chassis**.



Note For more information about how to perform configuration procedures in Cisco UCS Manager, see the appropriate [Cisco UCS Manager Configuration Guide](#).

Procedure

-
- Step 1** Move the traffic to the primary fabric interconnect. This can be performed in two ways: fabric evacuation and uplink disablement. Use the below flowchart to choose between the two based on your Cisco UCS domain

server and

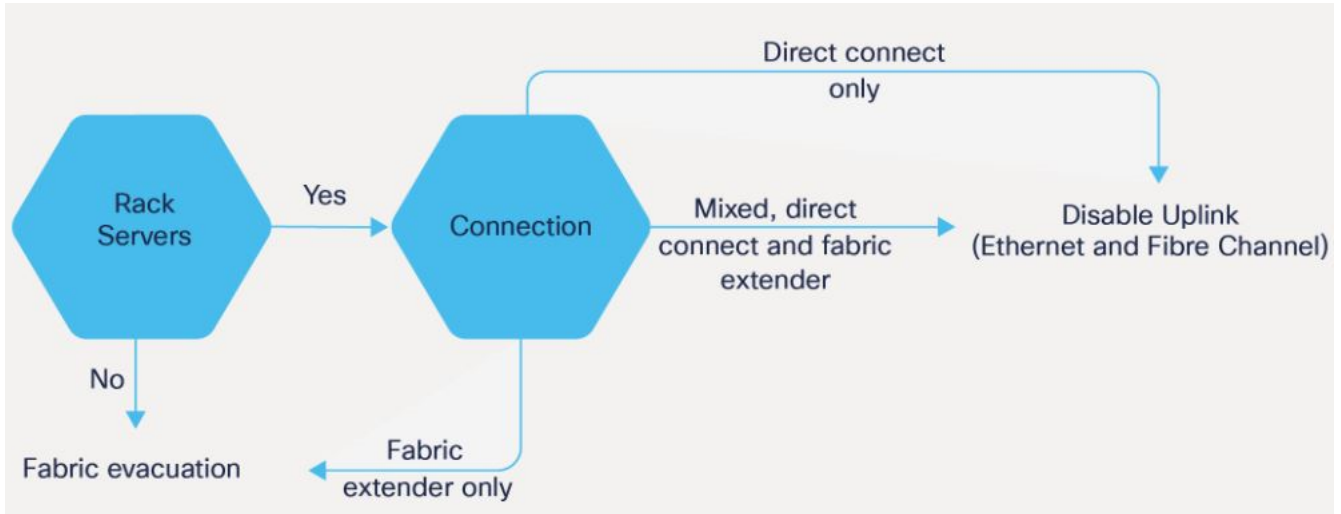

Note

For direct-attached rack servers, only uplink disablement is supported.

Step 2 Verify that all traffic has failed over to the primary fabric interconnect. Unconfigure all server ports or fibre channel ports on the subordinate fabric interconnect.

For more information, see the *Fabric Interconnect Traffic Evacuation* section in the *Guidelines and Prerequisites* chapter of the [Cisco UCS Manager Firmware Management Guide](#).

Step 3 Power down the old subordinate fabric interconnect and disconnect the power and the L1/L2 cables.

If you are monitoring the migration using a KVM session to a server host, you may need to reconnect it after you powered down the secondary fabric interconnect.

Step 4 Mount the replacement Cisco UCS 6536 Fabric Interconnect into either the same rack or an adjacent rack.

Note

As a best practice, you should label the cables.

Step 5 Connect the L1/L2 cables and the server ports according to your port mapping plan.

Step 6 Power up the new fabric interconnect. If it is connected correctly, the new subordinate fabric interconnect will detect that it is being added to an existing cluster.

Step 7 The subordinate Cisco UCS 6536 Fabric Interconnect will automatically synchronize the configuration and database/state information from the primary UCS 6400 Series Fabric Interconnect.

Synchronization between primary and subordinate fabric interconnects can take several minutes. You may see an error message that will persist until the server ports are enabled.

The port configuration is copied from the subordinate Fabric Interconnect to the new Fabric Interconnect.

Step 8 Unified ports on the 6500 series fabric interconnect are different from the unified port ordering on the 6400 series Fabric Interconnect.

Note

- When you convert from ethernet ports to fibre channel ports, a reboot is required. Fibre channel ports are converted in blocks of four (breakout ports).

- For more information on *Configuring FC Uplink port* or *Converting FC storage port to FC uplink port*, see the *LAN Ports and Port Channels* chapter in [Cisco UCS Manager Network Management Guide](#).

- Step 9** Configure the network uplink ports on the new Cisco UCS 6536 fabric interconnect.
- Step 10** Match the old configuration from Cisco UCS 6400 Fabric Interconnect for the port-channel. Add uplink ports to the necessary port-channel or any other previous configuration required for the port-channel. Wait for configuration to complete before proceeding to the next step.

Note

Waiting to enable the server ports prevents the svc_sam_bladeAG service from communicating with chassis and servers. In previous migrations, when enabling server ports at the same time as the uplink ports, it would cause topping out (pinning) the CPU to near 100% on the primary fabric interconnect. When there is high CPU usage, the user interface becomes unresponsive and the svc_sam_bladeAG service must be restarted to recover.

- Step 11** Reconfigure the server ports or fibre channel ports.
- a) If you have changed port mappings, you may need to reacknowledge the IOM, FEX, or direct-connect rack server connected to the subordinate fabric interconnect.
 - b) Verify and if necessary, you can reconfigure ethernet ports as server ports.
 - c) Skip to Step 13 to verify the data path.
- Step 12** To remove and replace the new IOM or FEX and reconfigure the server ports, do the following:
- a) Remove the existing IOM connected to the subordinate Fabric Interconnect and replace it with a supported IOM of Cisco UCS 6536 Fabric Interconnect.
 - b) Verify if any modifications are required for the cable connections.
 - c) Reconfigure the new IOM to maintain the same port mappings. If port mapping were not preserved, configure the server ports accordingly.
 - d) Reacknowledge the IOM connected to the subordinate Fabric Interconnect.
- Step 13** Verify that the data path is ready.
- For more information, see the *Verifying that Dynamic vNICs Are Up and Running* section in the *Guidelines and Prerequisites* chapter of the [Cisco UCS Manager Firmware Management Guide](#).
- Ensure that all faults are resolved before proceeding with next step.
- a) Verify, and if necessary, reconfigure the SAN pin group for fibre channel ports in the associated service profile.
 - b) Verify, and if necessary, reconfigure the LAN pin group for ethernet ports in the associated service profile.
 - c) Verify, and if necessary, reconfigure the port channel for uplink ethernet ports.
- Step 14** Move the traffic back to the new subordinate fabric interconnect. If you used the fabric evacuation method, then deselect fabric evacuation. If you disabled the uplinks (Ethernet and Fibre Channel), then re-enable the uplinks. Verify that traffic is flowing correctly on the new subordinate fabric interconnect.
- Step 15** After verifying that traffic is flowing on the subordinate fabric interconnect, promote the subordinate fabric interconnect to primary using the below commands:

- UCS-A #connect local-mgmt: This command connects to the local management interface of the cluster.
- UCS-A (local-mgmt) #cluster{lead {a|b}} or UCS-A (local-mgmt) #cluster{force primary {a|b}}: The cluster lead command and cluster force primary command are two separate commands that can be used for promoting the fabric interconnect.

Note

Ensure that the primary fabric interconnect is Cisco UCS 6536 Fabric Interconnect.

Step 16

Cable the second new fabric interconnect identically to the first and repeat the steps for the other fabric interconnect replacements to complete the migration.



CHAPTER 5

Migrating to Cisco UCS 6400 Series Fabric Interconnect

- [Cisco UCS 6454 Fabric Interconnect to Cisco UCS 64108 Fabric Interconnect Migration](#), on page 45

Cisco UCS 6454 Fabric Interconnect to Cisco UCS 64108 Fabric Interconnect Migration

Cisco UCS 6400 Series Fabric Interconnect Migration Considerations

Cisco UCS Manager provides support for migrating Cisco UCS 6454 Fabric Interconnect to Cisco UCS 64108 Fabric Interconnect with B-Series servers, C-Series, or S-Series servers.

To migrate from Cisco UCS 6454 Fabric Interconnect to Cisco UCS 64108 Fabric Interconnect, both the Fabric Interconnect must be loaded with the same Infrastructure Firmware version.

Prerequisites

Before performing the migration from Cisco UCS 6454 Fabric Interconnects to Cisco UCS 64108 Fabric Interconnect, ensure that the following prerequisites are met for a successful migration:

- Back up and export Cisco UCS Manager configuration before initiating the upgrade.
- Take an inventory of the Cisco UCS domain and remove any unsupported hardware.
- Ensure to enable the cluster failover.
- Do not attempt to implement new software features from the new Cisco UCS software version until all required hardware is installed.
- Make sure both Cisco UCS 6400 series Fabric Interconnects are on the same UCSM build before migration.
- Standalone installations should expect down time. In a cluster configuration, migrating the Fabric Interconnects can result in a small traffic disruption when the traffic fails over from one Fabric Interconnect to another. To avoid that there is no permanent traffic loss during migration, ensure that there is redundancy in the UCS domain on both Fabric Interconnects before migration and test the redundancy before starting the migration.

- Ensure the latest firmware bundle is downloaded and upgraded through GUI or CLI. In case of attempting to upgrade the firmware bundle using other methods (loader prompt/erase configuration) can result in missing package version.
- Before migration, make sure that the FC Speed is 8Gbps on Cisco UCS 6454 Fabric Interconnects or the connected switch supports 8Gbps speed.



Note Post migration, you can configure the FC Port (Scalability Port) speed on Cisco UCS 64108 Fabric Interconnects.

- Migrating to different IOM models can result in peer communication issue between IOMs of the Primary and Secondary Fabric Interconnects.
- Make a detailed record of the cabling between FEX and fabric interconnects. You must preserve the physical port mapping to maintain the server pinning already configured and minimize down time.
- For a cluster configuration, both fabric interconnects must have symmetrical connection topologies between fabric interconnect and FEX.
- Use the same speed cables on all the adapter ports that are connected to same Fabric Interconnect. Cisco UCS VIC adapter ports connected to Cisco UCS 64108 fabric interconnect through a mix of 10G and 25G cables can result in UCS rack-mount server discovery failure and ports moving to suspended state.
- A WWN pool can include only WWNNs or WWPNS in the ranges from 20:00:00:00:00:00:00:00 to 20:FF:00:FF:FF:FF:FF:FF or from 50:00:00:00:00:00:00:00 to 5F:FF:00:FF:FF:FF:FF:FF. All other WWN ranges are reserved. When fibre channel traffic is sent through the UCS infrastructure the source WWPNS is converted to a MAC address. You cannot use WWPNS pool which can translate to source multicast MAC addresses. To ensure the uniqueness of the Cisco UCS WWNNs and WWPNS in the SAN fabric, Cisco recommends using the following WWN prefix for all blocks in a pool: 20:00:00:25:B5:XX:XX:XX

Recommendations

Following are the best practices for a successful migration:

- For minimal disruption during migration, ensure that there is redundancy for Ethernet and FC traffic from the servers in the UCS domain across both 6454 Fabric Interconnects before migration.
- Changes to the topology, such as the number of servers or uplink connections, should be performed after the fabric interconnect migration is complete.
- During the migration of Fabric Interconnects, ensure the Cluster ID is not changed.
- During the migration, image synchronization between fabric interconnects is not allowed. This is done to prevent incompatible images from getting synchronized. It is necessary to download B-Series, C-Series, and S-Series server software bundles again after migration is complete.
- Unconfigure the fibre channel ports on the migrating subordinate Cisco UCS 6454 Fabric Interconnect and reconfigure on the Cisco UCS 64108 Fabric Interconnect.



Note For more information, see [Considerations for migrating Cisco UCS 6454 Fabric Interconnects to Cisco UCS 64108 Fabric Interconnects with Cisco UCS Central](#), on page 47.

Validating Feature Configurations for Cisco UCS 64108 Fabric Interconnect before Upgrade

Table 6: Features that needs special attention prior to upgrading

Feature	Remediation
Chassis and fabric extender I/O port channel	Select a port channel to the I/O module (IOM).
Multicast optimization	Verify that multicast optimization is not enabled under the LAN quality-of-service (QoS) system classes
Fabric forwarding mode for Ethernet	Verify that the Ethernet forwarding mode is set to End Host Mode Only .
Fabric forwarding mode for Fibre Channel	Verify that Fibre Channel forwarding mode is set to End Host Mode or FC Switching Mode .
Cisco NetFlow	Unconfigure NetFlow.
MAC Security	Select Allow for MAC security.
VM-FEX	Remove port profiles and Cisco UCS Manager ESXi or SCVMM related configurations.
Dynamic vNIC connection policies	Set the dynamic vNIC connection policy in the vNIC profile to Not set .
Cisco Switched Port Analyzer (SPAN)	Use receive (RX) direction only. The installer will change SPAN to the RX direction and send an alert indicating that this setting is being changed.

Failure to comply with these remediation steps will result in a migration warning alert during the migration process and prevent the fabric interconnects from synchronizing.

Considerations for migrating Cisco UCS 6454 Fabric Interconnects to Cisco UCS 64108 Fabric Interconnects with Cisco UCS Central

In addition to [Cisco UCS 6400 Series Fabric Interconnect Migration Considerations](#), on page 45, consider the following prerequisites when migrating with Cisco UCS Central:

- Before initiating the migration, ensure to have a complete backup of Cisco UCS Manager and UCS Central configurations.
- To avoid any configuration issues during migration, make sure the following policies on Policy Resolution Control is set to Local in Cisco UCS Manager:
 - Infrastructure and Catalog Firmware Policy

- Equipment Policy
- Port Configuration Policy

Migrating from UCS 6454 Fabric Interconnects to UCS 64108 Fabric Interconnects

Beginning with Cisco UCS Manager Release 4.1, you can migrate from Cisco UCS 6454 Fabric Interconnect to Cisco UCS 64108 Fabric Interconnect.

To acknowledge the chassis in Cisco UCS Manager, do the following:

1. In the Navigation pane of Cisco UCS Manager, click **Equipment**.
2. Click the **Equipment** node.
3. In the Work pane, click the **Policies** tab.
4. Click the **Global Policies** subtab.
5. Expand **Equipment > Chassis**, and choose the chassis that you want to acknowledge.
6. In the Work pane, click the **General** tab.
7. In the **Actions** area, click **Acknowledge Chassis**.



Note For more information about how to perform configuration procedures in Cisco UCS Manager, see the appropriate [Cisco UCS Manager Configuration Guide](#).

Procedure

-
- Step 1** Move the traffic to the primary fabric interconnect (Cisco UCS 6454). This can be performed in two ways: fabric evacuation and uplink disablement. Use the below flowchart to choose between the two based on your Cisco UCS domain server and connectivity.

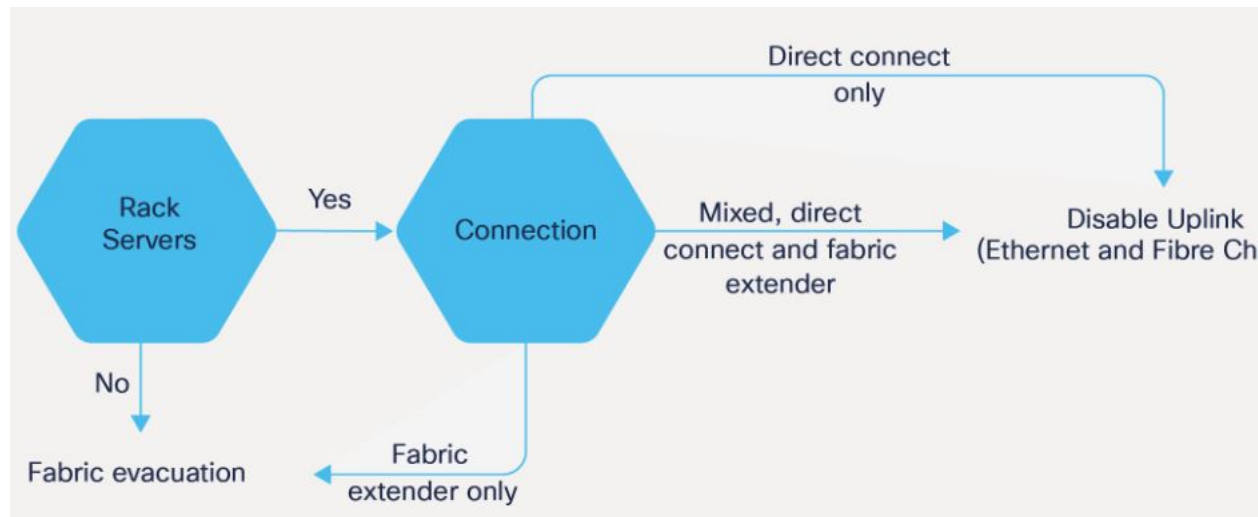

Note

For direct-attached rack servers, only uplink disablement is supported.

Step 2 Verify that all traffic has failed over to the primary fabric interconnect. Unconfigure all the server ports or fibre channel ports on the subordinate fabric interconnect.

Note

For more information, see the *Fabric Interconnect Traffic Evacuation* section in the *Guidelines and Prerequisites* chapter of the [Cisco UCS Manager Firmware Management Guide](#).

Step 3 Power down the UCS 6454 subordinate fabric interconnect and disconnect the power and the L1/L2 cables.

Step 4 Mount the replacement UCS 64108 Fabric Interconnect into either the same rack or an adjacent rack.

Note

As a best practice, you should label the cables.

Step 5 Connect the L1/L2 cables and the server ports according to your port mapping plan.

Step 6 Power up the new fabric interconnect. If it is connected correctly, the new subordinate fabric interconnect will detect that it is being added to an existing cluster.

Step 7 Enter the IP address information for the new subordinate fabric interconnect.

Step 8 Unified ports on the UCS 6454 fabric interconnect are similar to the unified port ordering on the 64108 fabric interconnect.

Note

- When you convert from ethernet ports to fibre channel ports, a reboot is required.
- For more information on *Configuring FC Uplink port* or *Converting FC Storage Port to FC Uplink port*, refer the *LAN Ports and Port Channels* chapter in [Cisco UCS Manager Network Management Guide](#).

Step 9 Configure the network uplink ports on the new Cisco UCS 64108 fabric interconnect.

Step 10 Match the old configuration from 6454 for the port-channel. Add uplink ports to the necessary port-channel or any other previous configuration required for the port-channel. Wait for configuration to complete before proceeding to the next step.

Note

Waiting to enable the server ports prevents the `svc_sam_bladeAG` service from communicating with chassis and servers. In previous migrations, when enabling server ports at the same time as the uplink ports, it would cause topping out (pinning) the CPU to near 100% on the primary fabric interconnect. When there is high CPU usage, the user interface becomes unresponsive and the `svc_sam_bladeAG` service must be restarted to recover.

Step 11 Reconfigure the server ports or fibre channel ports.

- a) If you have changed port mappings, you may need to reacknowledge the IOM, FEX, or direct-connect rack server connected to the subordinate fabric interconnect.
- b) Verify and if necessary, you can reconfigure ethernet ports as server ports.

Step 12 The 64108 subordinate fabric interconnect will automatically synchronize the configuration and database/state information from the primary UCS 6454 fabric interconnect.

Synchronization between primary and subordinate fabric interconnects can take several minutes. You may see an error message that will persist until the server ports are enabled.

The port configuration is copied from the subordinate fabric interconnect to the new fabric interconnect.

Step 13 Reconfigure the Ethernet ports, Fibre Channel ports, or unified ports.

- a) If you have changed port mappings for direct-attach rack server, reacknowledge the server.
- b) It is recommended to reacknowledge the IOM or FEX.

Note

You should login directly to the new Cisco UCS 6454 Fabric Interconnect GUI to configure the unified ports during the migration.

Step 14 Verify that the data path is ready.

For more information, see the *Verifying that Dynamic vNICs Are Up and Running* section in the *Guidelines and Prerequisites* chapter of the [Cisco UCS Manager Firmware Management Guide](#).

Ensure that all faults are resolved before proceeding with next step.

- a) Verify, and if necessary, reconfigure the SAN pin group for Fibre Channel ports in the associated service profile.
- b) Verify, and if necessary, reconfigure the LAN pin group for Ethernet ports in the associated service profile.
- c) Verify, and if necessary, reconfigure the port channel for uplink Ethernet ports.

Step 15 Move the traffic back to the new subordinate fabric interconnect. If you used the fabric evacuation method, then deselect fabric evacuation. If you disabled the uplinks (Ethernet and Fibre Channel), then reenabling the uplinks. Verify that traffic is flowing correctly on the new subordinate fabric interconnect.

Step 16 After verifying that traffic is flowing on the subordinate fabric interconnect, promote the subordinate fabric interconnect to primary using the below commands:

- `UCS-A #connect local-mgmt`: This command connects to the local management interface of the cluster.
- `UCS-A (local-mgmt) #cluster{lead {a|b}}` or `UCS-A (local-mgmt) #cluster{force primary {a|b}}`: The cluster lead command and cluster force primary command are two separate commands that can be used for promoting the fabric interconnect.

Note

Ensure that the primary fabric interconnect is Cisco UCS 64108 fabric interconnect.

- Step 17** Cable the second new fabric interconnect identically to the first and repeat the steps for the other fabric interconnect replacement to complete the migration.
-



CHAPTER 6

Appendix

- [Appendix, on page 53](#)

Appendix

This section provides a list of terminologies that are used in this document.

Name	Description
Direct-Connect	C-Series VIC connections that are plugged directly into the Fabric Interconnect port.
Ethernet Port	A generic term for the opening on the side of any Ethernet node, typically in an Ethernet NIC or LAN switch, into which an Ethernet cable can be connected.
Fabric Port Channel	Fibre Channel uplinks defined in a Cisco UCS Fabric Interconnect, bundled together and configured as a port channel, allowing increased bandwidth and redundancy.
FCoE	Fibre Channel over Ethernet. A computer network technology that encapsulates Fibre Channel frames over Ethernet networks.
KVM	Keyboard, video, and mouse
MAC address	A standardized data link layer address that is required for every device that connects to a Logical Area Network (LAN).
Port Mappings	Identifies the ports that are used for specific cable connections between the Fabric Interconnect and other devices.

