



Overview

- [About the Cisco UCS S3260 System, on page 1](#)
- [How to Use This Guide, on page 3](#)
- [Cisco UCS S3260 System Architectural Overview, on page 5](#)
- [Connectivity Matrix , on page 7](#)
- [Deployment Options, on page 8](#)
- [Management Through Cisco UCS Manager, on page 9](#)
- [Server SIOC Connectivity Functionality, on page 11](#)
- [New SIOC with PCIe Slots, on page 13](#)

About the Cisco UCS S3260 System

The Cisco UCS S3260 is a dense storage rack server with dual server nodes, optimized for large data sets used in environments such as Big data, cloud, object storage, and content delivery. It belongs to the Cisco UCS S-Series rack-mount servers product family.

Beginning with Cisco UCS Manager Release 3.1(3), Cisco UCS C3260/C3X60 is renamed to Cisco UCS S3260. You may still see certain components in the system labeled as C3260/C3X60. For this release, the terms S3260 and C3260/C3X60 are used interchangeably. Both, S3260 and C3260/C3X60, refer to the same hardware component.

Cisco UCS Manager Release 3.2(3) introduces Cisco UCS S3260 M5 server. Cisco UCS S3260 M5 server integrates with Cisco UCS Manager the same way Cisco UCS S3260 does. The information and procedures in this document can be used for Cisco UCS S3260 M4 and Cisco UCS S3260 M5 servers.

The Cisco UCS S3260 system is designed to operate in a standalone environment and as part of the Cisco Unified Computing System with Cisco UCS Manager integration. It assumes almost the same characteristics of its predecessor, Cisco UCS C3160, but with the following additional features:

- System IO Controllers (SIOC) with Cisco VIC 1300 and 1400 Series Embedded Chip supporting 10/25/40/100G speeds.
- Support of up to two server modules
- Capability to operate in a standalone mode and with Cisco UCS Manager
- Individual hard disk drives (HDD) can be assigned to either server in the dedicated or shared mode

In addition, one of the server slots in the Cisco UCS S3260 system can be utilized by a storage expansion module for an additional four 3.5" drives. The server modules can also accommodate two solid state drives (SSD) for internal storage dedicated to that module. The chassis supports Serial Attached SCSI (SAS) expanders that can be configured to assign the 3.5" drives to individual server modules.

Beginning with release 3.1(3), Cisco UCS S3260 system supports the following:

- Server SIOC Connectivity functionality
- Second RAID controller in the optional I/O expander module
- Dual HBA Controller



Note If a Cisco UCS S3260 system has Dual HBA Controller then you cannot downgrade Cisco UCS Manager to any release earlier than 3.1(3).

In a Cisco UCS S3260 system, both servers should have either dual RAID controllers or dual HBA controllers. Mixing the controller types is not supported.

Cisco UCS S3260 system supports Server SIOC Connectivity functionality. Using this functionality, you can configure the data path through both the primary and auxiliary SIOCs when the chassis has single server and dual SIOCs set up. For more details, see [Server SIOC Connectivity Functionality, on page 11](#).

Cisco UCS S3260 system supports Second RAID controller in the optional I/O expander module that attaches to the top of the server node. You cannot downgrade Cisco UCS Manager, BMC, CMC, and BIOS to any release earlier than 3.1(3) depending on the number of disk zoned to the controllers :

Controller Configuration	Is Downgrade Possible?
Two controllers in the server (one in optional I/O expander) or one controller in the server (in optional I/O expander) and at least one disk is zoned to the controller in the optional I/O expander.	No
Two controllers in the server (one in optional I/O expander) or one controller in the server (in optional I/O expander) and at least one disk is pre-provisioned to controller in the optional I/O expander.	No
Two controllers in the server (one in optional I/O expander) or one controller in the server (in any slot) and disk are not zoned or pre-provisioned to the controller in optional I/O expander.	Yes

License Requirement

Beginning with release 4.2(3b), for Cisco UCS 6536 Fabric Interconnect (UCS-FI-6536), all ports are enabled using a term-based subscription license (Supported license term: 36-60 months).



Note Licensing for FI 6536 is not a port-based license like in previous FI generations.

ETH_PORT_ACTIVATION_PKG (for 6200/6400 FI series), 40G_ETH_PORT_ACTIVATION_PKG (for 6400 and 6300 FI - 6332), 10G_PORT_ACTIVATION_PKG (for 6300 FI - 6332-16UP), licenses are used when S3260 system is connected to FI as appliance (appliance port) or Cisco UCS Manager managed node (server port).

For more information on license requirement, refer *Server License Management* chapter in *Cisco UCS Manager Server Management Guide*.

How to Use This Guide

Cisco UCS S3260 systems managed through Cisco UCS Manager support most of the features that are supported by other S-Series Rack Servers managed through Cisco UCS Manager. Cisco UCS S3260 systems also introduce some new features and management capabilities to Cisco UCS Manager. These features and management capabilities are detailed in the following chapters of this guide:

- **Overview**—Provides detailed information about the architecture of the Cisco UCS S3260 system and its connectivity when managed through Cisco UCS Manager.
- **Migration to Cisco UCS Manager-Managed Cisco UCS S3260**—Describes the steps required to migrate either a standalone Cisco UCS C3160 or a standalone Cisco UCS S3260 server to a Cisco UCS Manager-managed Cisco UCS S3260 server.
- **System Related Policies**—Describes the chassis discovery policy and chassis connectivity policy that are applicable to Cisco UCS S3260 systems.
- **Chassis Profiles**—Provides detailed information about Chassis Profiles and Chassis Profile Templates, which can now be used to define the storage, firmware and maintenance characteristics of a Cisco UCS S3260 chassis.
- **Storage Management**—Describes the new storage components in a Cisco UCS S3260 system, and how to manage them.
- **Firmware Management**—Provides detailed information about Chassis Firmware Packages and the endpoints of Cisco UCS S3260 on which firmware can be updated manually.
- **Chassis Management**—Provides detailed information about the management of the Cisco UCS S3260 chassis.
- **Server Management**—Provides detailed information about the management of the Cisco UCS S3260 Server Node.
- **SIOC Management**—Provides detailed information about the management of the System Input/Output controllers (SIOCs) that are part of a Cisco UCS S3260 chassis.

All features and configuration tasks that are supported by Cisco UCS Manager Release 3.1 and later releases are described in the configuration guides that are listed in the following table. These guides must be used with this quick reference guide for Cisco UCS S3260 systems.

Guide	Description
Cisco UCS Manager Getting Started Guide	Discusses Cisco UCS architecture and Day 0 operations, including Cisco UCS Manager initial configuration and configuration best practices.

Guide	Description
Cisco UCS Manager Administration Guide	Discusses password management, role-based access configuration, remote authentication, communication services, CIMC session management, organizations, backup and restore, scheduling options, BIOS tokens, and deferred deployments.
Cisco UCS Manager Infrastructure Management Guide	Discusses physical and virtual infrastructure components used and managed by Cisco UCS Manager.
Cisco UCS Manager Firmware Management Guide	Discusses downloading and managing firmware, upgrading through Auto Install, upgrading through service profiles, directly upgrading at endpoints using firmware auto sync, managing the capability catalog, deployment scenarios, and troubleshooting.
Cisco UCS Manager Server Management Guide	Discusses the new licenses, registering Cisco UCS domain with Cisco UCS Central, power capping, server boot, server profiles, and server-related policies.
Cisco UCS Manager Storage Management Guide	Discusses all aspects of storage management, such as SAN and VSAN in Cisco UCS Manager.
Cisco UCS Manager Network Management Guide	Discusses all aspects of network management, such as LAN and VLAN connectivity in Cisco UCS Manager.
Cisco UCS Manager System Monitoring Guide	Discusses all aspects of system and health monitoring, including system statistics in Cisco UCS Manager.
Cisco UCS S3260 Server Integration with Cisco UCS Manager	Discusses all aspects of management of UCS S-Series servers that are managed through Cisco UCS Manager.

The [Release Notes for Cisco UCS Manager, Release 4.1](#) has detailed information about new features, resolved caveats, open caveats, and workarounds for Cisco UCS Manager, Release 4.1.

Cisco UCS S3260 System Architectural Overview

Architectural Overview

Figure 1: Cisco UCS S3260 System Overall Architecture Diagram

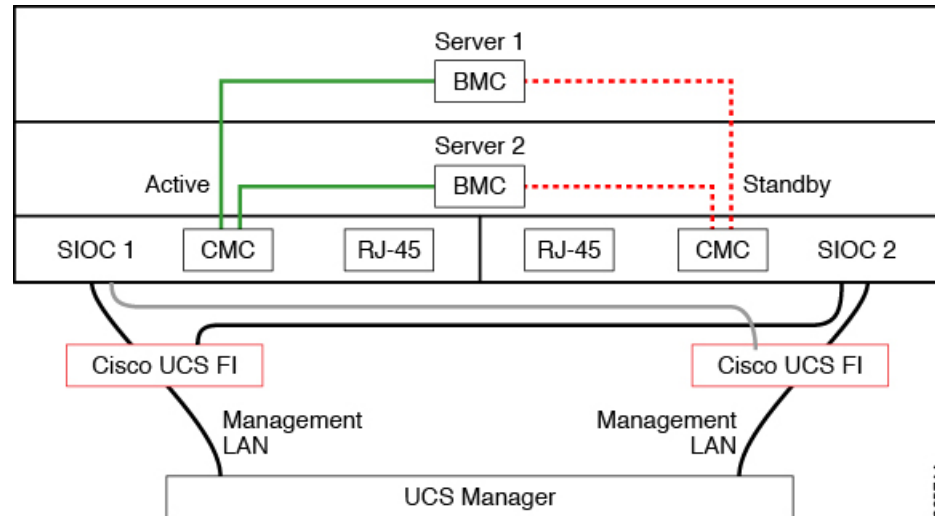
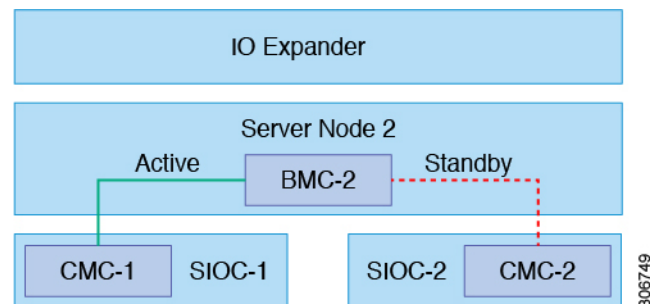

Figure 2: Cisco UCS S3260 System (with Single node Dual SIOC) Overall Architecture Diagram



The system uses a chassis management controller (CMC) to manage the server nodes. Each system I/O controller (SIOC) module contains an onboard CMC. If you have two SIOCs, the two CMCs act in an active/standby organization. The CMC in the SIOC that you log into with the Cisco IMC interface becomes the active CMC and it allows you to manage the BMCs in both server nodes.

All user interfaces run only on the active CMC. Configuration changes are automatically synchronized between the active and the standby CMCs.

When you power-cycle the system, the CMC in SIOC 1 is the active CMC by default. The active CMC will fail over to the standby CMC when any of the following conditions occur:

- The active CMC is rebooted or fails.
- The SIOC with active CMC is removed.
- Network connectivity is lost on the active CMC.

Building Blocks and Connectivity

The Cisco UCS S3260 chassis has a modular architecture consisting of the following modules:

Base Chassis

Contains four power supplies, eight fans, and a rail kit.

Server Node

One or two server nodes, each with two CPUs, 128, 256, or 512 GB of DIMM memory, and a RAID card in pass-through mode or a RAID card with a 1 GB or 4 GB cache.

System I/O Controller (SIOC) (Release 4.0(1) onwards)

Beginning with release 4.0(1), Cisco UCS S3260 system supports a new server SIOC UCS-S3260-PCISIOC with S3260 M5 servers. This SIOC has PCIe slots to replace the network adapters.

System I/O Controller (SIOC) (Release 3.2(3) and earlier)

One or two System I/O Controllers, each of which includes a 1300-series VIC. The Cisco UCS S3260 SIOC has an integrated Cisco UCS VIC 1300 Series chip onboard, so there is no removable adapter card.

Optional Drive Expansion Node

Choice of either 4 x 4 TB drives (total capacity: 16TB), 4 x 6 TB drives (total capacity: 24 TB), or 4 x 10 TB drives (total capacity: 40TB).

Solid-State Boot Drives

Up to two SSDs per server node.

Cisco UCS Fabric Connectivity

The Cisco UCS S3260 chassis can be connected in one of the following ways:

- Direct connection to the fabric interconnects.
- Connectivity using FEX.

Direct Connection to Cisco UCS Fabric Interconnects

1. **Cisco UCS 6200 Series Fabric Interconnects:** The SIOCs can be connected directly to the 6248 FI ports. The SIOC uplink can be connected to an FI port in one of two ways:
 - 10G connectivity to a single FI port using a QSA cable
 - 4*10G port channel connectivity to 4 FI ports using a break-out cable
2. **Cisco UCS 6300 Series Fabric Interconnects:** The SIOC uplink can be connected directly to a 6300 Series FI port through a single 40G connection.
3. **Cisco UCS 6400 Series Fabric Interconnect:** The SIOC uplink can be connected directly to a Cisco UCS 6400 Series Fabric Interconnect port through a single 25G connection.
4. **Cisco UCS 6536 Fabric Interconnect:** The SIOC uplink can be connected directly to a Cisco UCS 6536 Fabric Interconnect port through a single 25G connection.

Connectivity using FEX

N2348UPQ and 2232 FEX: The SIOCs can be connected directly to the FEX ports through a single 10G connection using a QSA connector.

Connectivity Matrix

New Cisco VIC Card

Beginning with release 4.0(2a), Cisco UCS S3260 system supports the following new Cisco VIC card:

- Cisco UCS VIC 1495

Beginning with release 4.0(1a), Cisco UCS S3260 system supports the following new Cisco VIC card:

- Cisco UCS VIC 1455

Table 1: Connectivity Matrix

	Cable	Link Aggregation	Connection Speed	FEX Support	6200 FI Support	6300 FI Support	6400 FI Support	6536 FI Support
VIC 1495 (with new generation SIOC)	QSFP	Non Port-Channel	40G	No	No	Yes	No	Yes
VIC 1455 (with new generation SIOC)	SPF+	Port-Channel	2x10G	Yes	Yes	Yes	Yes	Yes
	Breakout Cable	Port-Channel	2x10G	No	No	Yes	No	Yes
	SFP28	Port-Channel	2x25G	No	No	No	Yes	Yes
SIOC	QSA (SFP+)	Non Port-Channel	10G	Yes	Yes	No	Yes	Yes
	QSFP	Non Port-Channel	40G	No	No	Yes	No	Yes
	Breakout Cable	Port-Channel	4x10G	No	Yes	No	Yes	Yes



Note With VIC 1455 (with new generation SIOC), there are 4 ports for integration to UCS fabric interconnects. Ports 1 and 2 should be connected to FI-A, and Ports 3 and 4 should be connected to FI-B, otherwise the server discovery fails. (For example, if Port 1 is connected to FI-A and Port 2 is connected to FI-B, the server discovery fails.)

Deployment Options

The following sections describe the three main deployment options for Cisco UCS S3260 systems—single and dual server connectivity.

Single Server Connectivity

The following illustration shows the associations for a single-server system:

- The data bus in server node 2 connects through SIOC 2.
- Server 2 SSDs 1 and 2 can be controlled by a RAID controller card in server node 2.

Figure 3: Single Server with I/O Expander

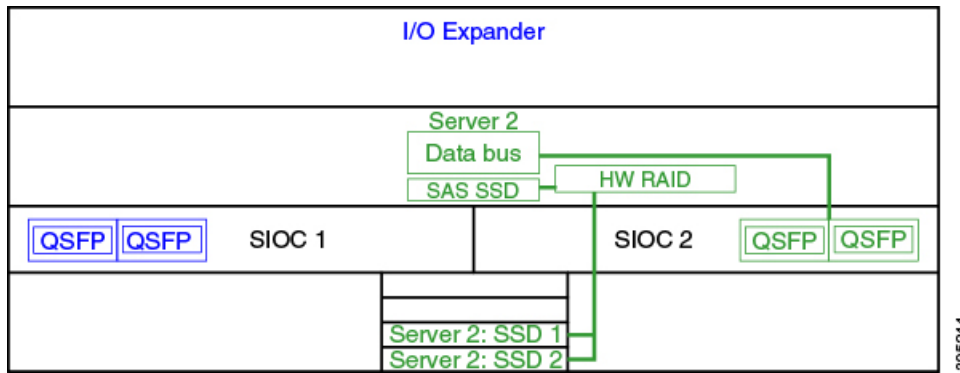

Single Server Connectivity (with Server SIOC Connectivity Functionality)

When a Cisco UCS S3260 system has single server and dual SIOCs, users can enable the Server SIOC Connectivity functionality. The following illustration shows the associations for a single-server system with Server SIOC Connectivity functionality enabled:

- The data bus in server node 2 connects through both the primary and auxiliary SIOCs.



Note Primary SIOC for server 1 is SIOC 1 and for Server 2 is SIOC 2. Auxiliary SIOC for server 1 is SIOC 2 and for server 2 is SIOC 1.

Figure 4: Single Server Single SIOC with Server SIOC Connectivity Functionality

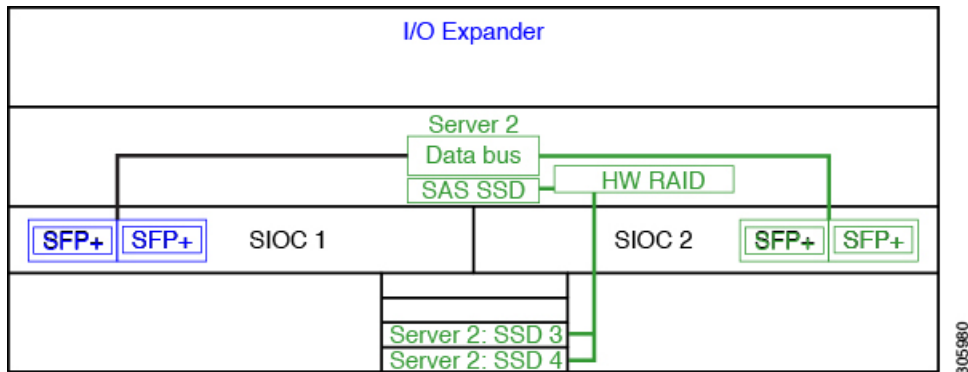

Dual Server Connectivity

In this mode of deployment, each server slot contains an independent server blade. The redundant server nodes along with the various components such as SAS SSDs provide high availability.

The following illustration shows a dual server system. For Cisco UCS C3X60 M3 server nodes, the PCH controller for Server 1 controls SSD1 and SSD2, and the PCH controller for Server 2 controls SSD3 and SSD4. For Cisco UCS C3X60 M4 server nodes, the RAID controller card on the servers controls the respective SSDs.

Figure 5: Dual Server System

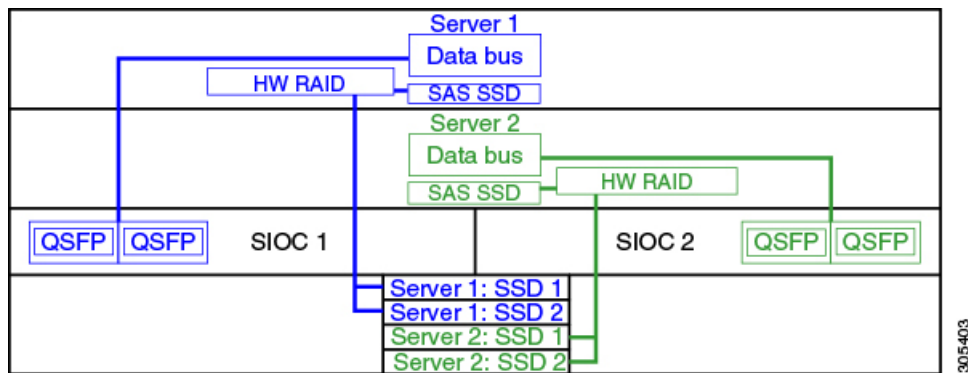

Important For detailed information on storage controller considerations for a Cisco UCS S3260 system such as storage controllers supported for the various server nodes and the associated service notes, please refer to the "Storage Controllers" section in the *Cisco UCS S3260 Storage Server Installation and Service Guide*.

Management Through Cisco UCS Manager

The Cisco UCS S3260 system can operate in either standalone mode or can be managed by Cisco UCS Manager.



Note UCS mini 6324 does not support Cisco UCS Manager integration of Cisco UCS S3260.

Dual Server Connectivity

The following illustration describes the connectivity for a Cisco UCS S3260 system with dual servers managed by Cisco UCS Manager:

Figure 6: Cisco UCS S3260 System with Cisco UCS Manager

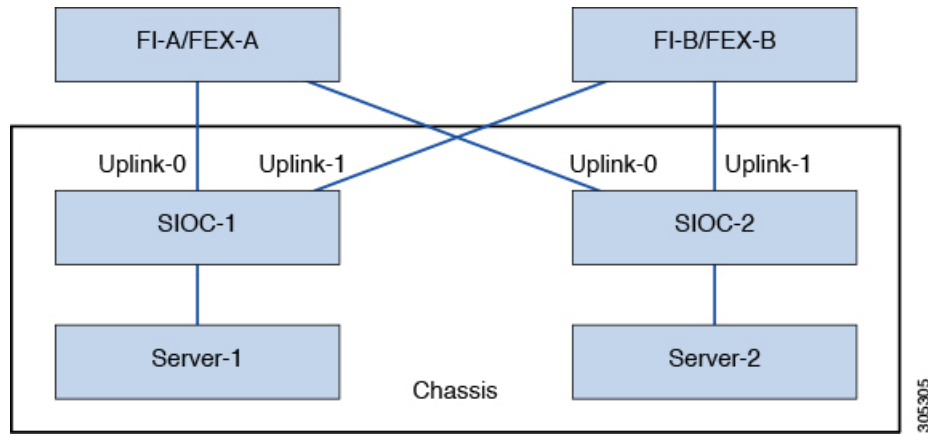

The 40G ports on the SIOCs can be connected to either a fabric interconnects or a FEX module. On each SIOC, one port can be connected to the primary fabric interconnect/FEX and the other port can be connected to the subordinate fabric interconnect/FEX. Traffic from each SIOC can reach fabric interconnects and FEXs.

Single Server and Single SIOC Connectivity

The following illustration describes the connectivity for a Cisco UCS S3260 system with single server and single SIOC managed by Cisco UCS Manager without Server SIOC Connectivity functionality :

Figure 7: Cisco UCS S3260 System with Cisco UCS Manager (Single Server Single SIOC without Server SIOC Connectivity Functionality)

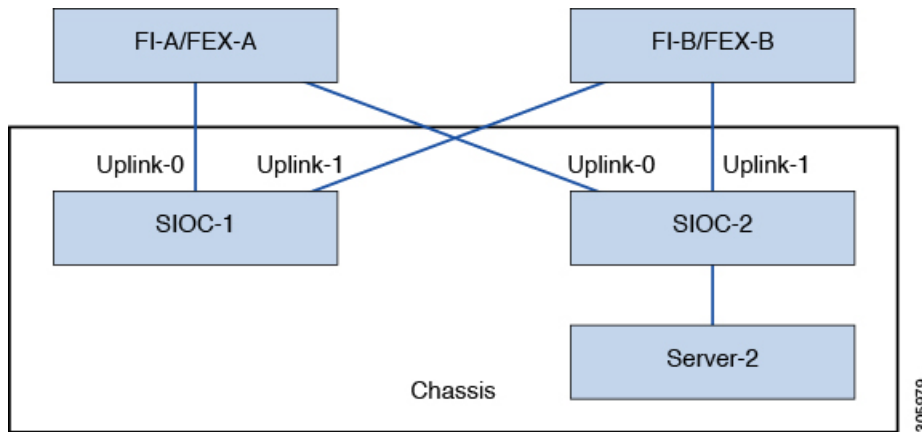

Single Server and Dual SIOC Connectivity (with Server SIOC Connectivity Functionality)

The following illustration describes the connectivity for a Cisco UCS S3260 system with single server and dual SIOCs managed by Cisco UCS Manager with the Server SIOC Connectivity functionality:

Figure 8: Cisco UCS S3260 System with Cisco UCS Manager (Single Server Single SIOC with Server SIOC Connectivity Feature)

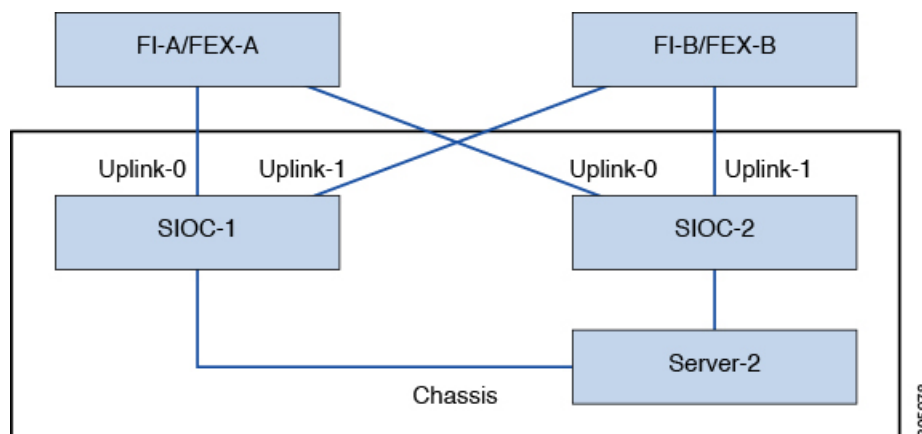

305978

Server SIOC Connectivity Functionality

Beginning with release 3.1(3), Cisco UCS S3260 system supports Server SIOC Connectivity functionality. Using this functionality, you can configure the data path through both the primary and auxiliary SIOCs when the chassis has single server and dual SIOCs set up.



Note Primary SIOC for server 1 is SIOC 1 and for Server 2 is SIOC 2. Auxiliary SIOC for server 1 is SIOC 2 and for server 2 is SIOC 1.

You can configure Server SIOC Connectivity functionality through chassis profile using **Compute Conn Policy** by selecting **single-server-dual-sioc** option.

Prerequisites for Server SIOC Connectivity Functionality

This functionality works only under the following conditions:

- Cisco UCS S3260 system is running release 3.1(3) or later.
- Associated BIOS, BMC and CMC firmware are running 3.1(3) or later.
- Chassis has single server and dual SIOCs.

Workflow - Cisco UCS Manager Upgrade

After Cisco UCS Manager is upgraded to release 3.1(3) or later release, chassis discovery is triggered and UCSM gets the operational state of Server SIOC Connectivity feature. User can now enable the feature using the **single-server-dual-sioc** option available for **Compute Conn Policy** under chassis profile.



Note Any change to Compute Connection Policy settings raises a pending-event. Chassis profile association starts automatically only after you acknowledge the pending-event.

In GUI, once **Compute Conn Policy** property is set to **single-server-dual-sioc**, then Cisco UCS Manager displays a message, warning that this operation causes server reboot. After acknowledging the message, chassis association is triggered. When Server SIOC Connectivity configuration is successfully deployed, Cisco UCS Manager automatically triggers server deep discovery.

In CLI, once **Compute Conn Policy** property is set to **single-server-dual-sioc**, run the **apply pending-changes immediate** command to start association.

Once **Compute Conn Policy** is set to **single-server-dual-sioc**, you cannot downgrade Cisco UCS Manager to any release earlier than 3.1(3). Similarly, Cisco UCS Manager prevents BMC, CMC, and BIOS downgrade to any release earlier than 3.1(3).

Conditions Impacting the Functionality when single-server-dual-sioc Option is Enabled

- Server Replacement - When the server is replaced, the blade slot mismatch is detected. When you acknowledge the slot, server deep discovery is triggered followed by service profile association. When service profile association is triggered, then there can be the following two situations:
 1. When BIOS/BMC firmware is specified in the host firmware. If the BIOS/BMC firmware support Single Server Dual SIOC connectivity, then the service profile association process continues. If the BIOS/BMC firmware do not support Single Server Dual SIOC connectivity, then the association raises a config-issue.
 2. When BIOS/BMC firmware is not specified in the host firmware. Cisco UCS Manager checks if the running BIOS/BMC version support Single Server Dual SIOC connectivity. If the feature is not supported, then a config-issue is raised.
- SIOC Replacement - If the replaced SIOC is running 3.1(3) or later, then a user acknowledgment message is displayed when one of the SIOC is seated. Once you acknowledge SIOC action, then Cisco UCS Manager establishes the connectivity between the FI and the SIOC. In addition to that Cisco UCS Manager re-acknowledges the server that has the data path connectivity through this SIOC. The VNICs configured for the server are also re-acknowledged. See [SIOC Removal or Replacement](#) for more information.

If the replaced SIOC is running an earlier firmware version, then Cisco UCS Manager automatically changes the **Server SIOC Connectivity** operational state to **single-server-single-sioc**. You may update the firmware of the replaced SIOC by re-triggering chassis profile association.
- SIOC Removal - When any SIOC is removed, Cisco UCS Manager marks the SIOC and the corresponding adapter unit created under the server as missing.
- Adding Server in Chassis - When a new server is added in the chassis with this functionality enabled, then server discovery fails.
- Chassis/Server Disassociation - Server SIOC Connectivity functionality is not disabled if a server or chassis is disassociated.

New SIOC with PCIe Slots

Beginning with Cisco UCS Manager release 4.0(1a), Cisco UCS S3260 systems support a new server SIOC, UCS-S3260-PCISIOC, with S3260 M5 servers. This SIOC has PCIe slots to replace the network adapters (See [Table 2: Supported Cisco VIC and Third-party Adapters, on page 13](#) for supported adapters). These slots support both Cisco VIC and third-party adapters. In addition, the new SIOC has two NVMe slots.

Beginning with Cisco UCS Manager release 4.0(2a), NVMe OOB is supported.

Figure 9: FI Connectivity with New SIOC

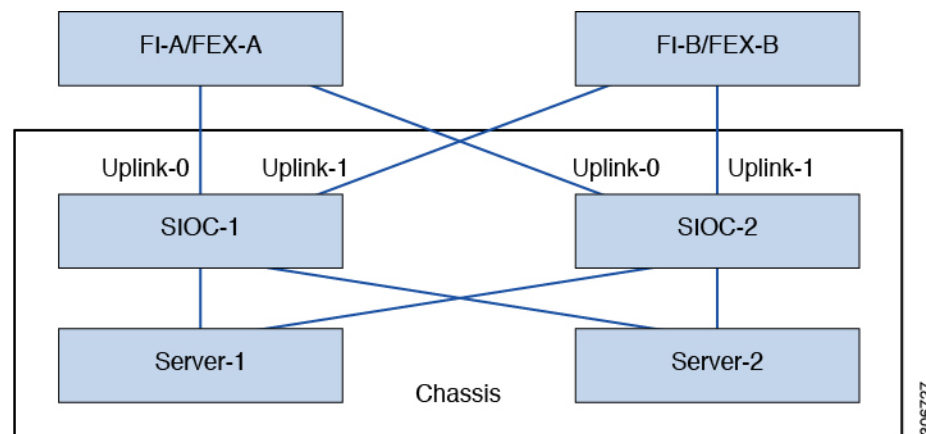

Table 2: Supported Cisco VIC and Third-party Adapters

PID	Description
UCSC-PCIE-C25Q-04	Cisco VIC 1455 Quad port – 25G
UCSC-PCIE-ID10GC	Intel X550 dual-port 10GB Base-T
UCSC-PCIE-ID25GF	Intel XXV710 dual-port 25G SFP28
UCSC-PCIE-ID40GF	Intel XL710 dual-port 40GB QSFP+ NIC
UCSC-PCIE-QD16GF	Qlogic QLE2692 dual-port 16G Fibre Channel HBA

Table 3: Supported NVMe Disks

PID	Description
UCS-S3260-NVG25	UCS S3260 500GB NVMe for M5 Server Node based on Intel 4501
UCS-S3260-NVG210	UCS S3260 1TB NVMe for M5 Server Node based on Intel 4501
UCS-S3260-NVG220	UCS S3260 2TB NVMe for M5 Server Node based on Intel 4501

Prerequisites for Installing New SIOC

- BMC firmware version should be 4.0(1a) or higher.
- CMC firmware version should be 4.0(1a) or higher.

Limitations for Cisco VIC Cards, Third-party Adapters, and NVMe Disks

- The SIOC with the third-party adapter can be set only as standby.
- If you reboot the active SIOC, it does not cause the SIOC attached to the third-party adapter to become active.
- Cisco UCS Manager does not support a setup with mixed SIOCs. You cannot mix new gen SIOCs and old SIOCs in a setup.
- Cisco UCS Manager does not manage the SIOC that has a third-party adapter in it.
- Cisco UCS Manager does not update or activate the CMC image of the SIOC that has a third-party adapter.
- Hot insertion and removal of NVMe disks are not supported.
- For more details on Cisco and third-party adapters support, see [Cisco UCS Manager Management for Mixed Adapter Set-up, on page 14](#).

Cisco UCS Manager Management for Mixed Adapter Set-up

Table 4: Cisco UCS Manager Management

Slot 1	Slot 2	Server SIOC Connection	Cisco UCS Manager Management
Cisco VIC	Cisco VIC	Single Server Dual VIC	Cisco UCS Manager provides full support
Cisco VIC	Cisco VIC	Dual Server Mode	Cisco UCS Manager provides full support
Cisco VIC	Third-party Adapter	Single Server Dual VIC	Cisco UCS Manager provides partial support: <ul style="list-style-type: none"> • Discovery and firmware management for third-party adapter • CMC redundancy is not supported in case of SIOC/VIC failure

Slot 1	Slot 2	Server SIOC Connection	Cisco UCS Manager Management
Cisco VIC	Third-party Adapter	Dual Server	<p>Cisco UCS Manager provides partial support:</p> <ul style="list-style-type: none"> • Discovery of server in slot 1 • CMC redundancy is not supported in case of SIOC/VIC failure • Discovery of server in slot 2 is not supported in Cisco UCS Manager mode. If there is a server in slot 2, Cisco UCS Manager discovery fails with the No Connected Adapters error.
Third-party Adapter	Cisco VIC	Single Server Dual VIC	<p>Cisco UCS Manager provides partial support:</p> <ul style="list-style-type: none"> • Discovery and firmware management for third-party adapter • CMC redundancy is not supported in case of SIOC/VIC failure

Slot 1	Slot 2	Server SIOC Connection	Cisco UCS Manager Management
Third-party Adapter	Cisco VIC	Dual Server	Cisco UCS Manager provides partial support: <ul style="list-style-type: none"> • Discovery of server in slot 2 • CMC redundancy is not supported in case of SIOC/VIC failure • Discovery of server in slot 1 is not supported in Cisco UCS Manager mode. If there is a server in slot 1, Cisco UCS Manager discovery fails with the <code>No Connected Adapters</code> error.
Third-party Adapter	Third-party Adapter	Single Server Dual VIC	Not supported
Third-party Adapter	Third-party Adapter	Dual Server	Not supported

SIOC Removal or Replacement

You can remove or replace an SIOC from a chassis. Removal or replacement of an SIOC is a service-affecting operation, which requires you to power down the entire chassis. See [SIOC Removal or Replacement](#) for more information.

Migrating to New SIOC with PCIe Support

See [Migrating to SIOC with PCIe Support](#) for more information. Once you migrate to new SIOC, the following downgrade restrictions are applied:

- You cannot downgrade Cisco UCS Manager to any release below 4.0(1a)
- You cannot downgrade BMC firmware to any release below 4.0(1a)

Server SIOC Connectivity Functionality

Cisco UCS Manager continues to support single server dual VIC functionality with the new SIOC with the following exceptions:

- The support is extended to third-party adapters connected to the new SIOC
- Once you change the **Compute Connection Policy** property to **single-server-dual-sioc**, the server is powered down before the policy is applied.

- Single server dual SIOC only decides the allocation of the adapter in the SIOC, it does not allocate the NVME disk slots in the SIOC. One NVMe disk is allocated per server and SIOC NVME connections to the servers are fixed.

