



Cisco UCS Central Getting Started Guide, Release 1.5

First Published: 2016-07-29

Last Modified: 2016-08-11

Americas Headquarters

Cisco Systems, Inc.
170 West Tasman Drive
San Jose, CA 95134-1706
USA
<http://www.cisco.com>
Tel: 408 526-4000
800 553-NETS (6387)
Fax: 408 527-0883

THE SPECIFICATIONS AND INFORMATION REGARDING THE PRODUCTS IN THIS MANUAL ARE SUBJECT TO CHANGE WITHOUT NOTICE. ALL STATEMENTS, INFORMATION, AND RECOMMENDATIONS IN THIS MANUAL ARE BELIEVED TO BE ACCURATE BUT ARE PRESENTED WITHOUT WARRANTY OF ANY KIND, EXPRESS OR IMPLIED. USERS MUST TAKE FULL RESPONSIBILITY FOR THEIR APPLICATION OF ANY PRODUCTS.

THE SOFTWARE LICENSE AND LIMITED WARRANTY FOR THE ACCOMPANYING PRODUCT ARE SET FORTH IN THE INFORMATION PACKET THAT SHIPPED WITH THE PRODUCT AND ARE INCORPORATED HEREIN BY THIS REFERENCE. IF YOU ARE UNABLE TO LOCATE THE SOFTWARE LICENSE OR LIMITED WARRANTY, CONTACT YOUR CISCO REPRESENTATIVE FOR A COPY.

The Cisco implementation of TCP header compression is an adaptation of a program developed by the University of California, Berkeley (UCB) as part of UCB's public domain version of the UNIX operating system. All rights reserved. Copyright © 1981, Regents of the University of California.

NOTWITHSTANDING ANY OTHER WARRANTY HEREIN, ALL DOCUMENT FILES AND SOFTWARE OF THESE SUPPLIERS ARE PROVIDED "AS IS" WITH ALL FAULTS. CISCO AND THE ABOVE-NAMED SUPPLIERS DISCLAIM ALL WARRANTIES, EXPRESSED OR IMPLIED, INCLUDING, WITHOUT LIMITATION, THOSE OF MERCHANTABILITY, FITNESS FOR A PARTICULAR PURPOSE AND NONINFRINGEMENT OR ARISING FROM A COURSE OF DEALING, USAGE, OR TRADE PRACTICE.

IN NO EVENT SHALL CISCO OR ITS SUPPLIERS BE LIABLE FOR ANY INDIRECT, SPECIAL, CONSEQUENTIAL, OR INCIDENTAL DAMAGES, INCLUDING, WITHOUT LIMITATION, LOST PROFITS OR LOSS OR DAMAGE TO DATA ARISING OUT OF THE USE OR INABILITY TO USE THIS MANUAL, EVEN IF CISCO OR ITS SUPPLIERS HAVE BEEN ADVISED OF THE POSSIBILITY OF SUCH DAMAGES.

Any Internet Protocol (IP) addresses and phone numbers used in this document are not intended to be actual addresses and phone numbers. Any examples, command display output, network topology diagrams, and other figures included in the document are shown for illustrative purposes only. Any use of actual IP addresses or phone numbers in illustrative content is unintentional and coincidental.

Cisco and the Cisco logo are trademarks or registered trademarks of Cisco and/or its affiliates in the U.S. and other countries. To view a list of Cisco trademarks, go to this URL: <http://www.cisco.com/go/trademarks>. Third-party trademarks mentioned are the property of their respective owners. The use of the word partner does not imply a partnership relationship between Cisco and any other company. (1110R)

© 2016 Cisco Systems, Inc. All rights reserved.



CONTENTS

Preface

Preface vii

Audience vii

Conventions vii

Related Cisco UCS Documentation ix

Documentation Feedback ix

CHAPTER 1

Overview 1

Overview 1

Cisco UCS Central User Documentation Reference 1

CHAPTER 2

Introduction to Cisco Unified Computing System Infrastructure 3

Cisco Unified Computing System Overview 3

Cisco UCS Manager Overview 5

CHAPTER 3

Introduction to Cisco UCS Central 7

Introducing Cisco UCS Central 7

Cisco UCS Central Features 8

Overview of Cisco UCS Central HTML 5 UI 9

Using the HTML5 UI 10

Dashboard Widgets 12

Adding Table Summary Widgets to the Dashboard 13

Adding Instance Summary Widgets to the Dashboard 14

Tab Navigator 14

Using the Tab Navigator 15

Common User Interface Options 15

Behavior and Design Changes in HTML5 UI 18

CHAPTER 4**Working with Cisco UCS Manager 19**

- Cisco UCS Domains and Cisco UCS Central 19
 - Registering a Cisco UCS Domain in Cisco UCS Central 20
 - Domain Registration Management 22
 - Unregistering a Cisco UCS Domain in Cisco UCS Central 23
 - Viewing Domain Registration Configuration Status 24
- Policies in Cisco UCS Central and Cisco UCS Domains 24
 - Policy Resolution between Cisco UCS Manager and Cisco UCS Central 25
 - Consequences of Policy Resolution Changes 27
 - Consequences of Service Profile Changes on Policy Resolution 31
- Domains and Domain Groups 31
 - Creating or Editing a Domain Group 32
 - Adding a Domain to a Domain Group 32
 - Managing Domain Group SNMP 33
- Domain Group Qualification Policy 33
 - Creating or Editing a Domain Group Qualification Policy 33
- Organization 34
 - Updating Organization Descriptions 34

CHAPTER 5**Tags 35**

- Tags and Tag Types 35
 - Creating a Tag Type 35
 - Adding a Tag 36

CHAPTER 6**License Management 37**

- Overview 37
 - Smart Licensing 37
 - Enabling Smart Licensing 39
 - Registering UCS Central Using a License Token 40
 - Renewing Authorization 40
 - Renewing Registration 41
 - Deregistering Smart Software Licensing 41
 - Disabling Smart Software Licensing 41
 - Traditional Licensing 42

[Obtaining a Traditional License](#) 42

[Downloading a License from a Local File System](#) 43

[Downloading a License from a Remote File System](#) 44

[Installing a License](#) 44

[Deleting a Traditional License](#) 45



Preface

- [Audience, page vii](#)
- [Conventions, page vii](#)
- [Related Cisco UCS Documentation, page ix](#)
- [Documentation Feedback, page ix](#)

Audience

This guide is intended primarily for data center administrators with responsibilities and expertise in one or more of the following:

- Server administration
- Storage administration
- Network administration
- Network security

Conventions

| Text Type | Indication |
|-----------------|--------------------------------------------------------------------------------------------------------------------------------------------------------------------------------------|
| GUI elements | GUI elements such as tab titles, area names, and field labels appear in this font . Main titles such as window, dialog box, and wizard titles appear in this font . |
| Document titles | Document titles appear in <i>this font</i> . |
| TUI elements | In a Text-based User Interface, text the system displays appears in <code>this font</code> . |
| System output | Terminal sessions and information that the system displays appear in <code>this font</code> . |

| Text Type | Indication |
|--------------|-----------------------------------------------------------------------------------------------------------------------------|
| CLI commands | CLI command keywords appear in this font . Variables in a CLI command appear in <i>this font</i> . |
| [] | Elements in square brackets are optional. |
| {x y z} | Required alternative keywords are grouped in braces and separated by vertical bars. |
| [x y z] | Optional alternative keywords are grouped in brackets and separated by vertical bars. |
| string | A nonquoted set of characters. Do not use quotation marks around the string or the string will include the quotation marks. |
| < > | Nonprinting characters such as passwords are in angle brackets. |
| [] | Default responses to system prompts are in square brackets. |
| !, # | An exclamation point (!) or a pound sign (#) at the beginning of a line of code indicates a comment line. |

**Note**

Means *reader take note*. Notes contain helpful suggestions or references to material not covered in the document.

**Tip**

Means *the following information will help you solve a problem*. The tips information might not be troubleshooting or even an action, but could be useful information, similar to a Timesaver.

**Timesaver**

Means *the described action saves time*. You can save time by performing the action described in the paragraph.

**Caution**

Means *reader be careful*. In this situation, you might perform an action that could result in equipment damage or loss of data.

**Warning****IMPORTANT SAFETY INSTRUCTIONS**

This warning symbol means danger. You are in a situation that could cause bodily injury. Before you work on any equipment, be aware of the hazards involved with electrical circuitry and be familiar with standard practices for preventing accidents. Use the statement number provided at the end of each warning to locate its translation in the translated safety warnings that accompanied this device.

SAVE THESE INSTRUCTIONS

Related Cisco UCS Documentation

Documentation Roadmaps

For a complete list of all B-Series documentation, see the *Cisco UCS B-Series Servers Documentation Roadmap* available at the following URL: <http://www.cisco.com/go/unifiedcomputing/b-series-doc>.

For a complete list of all C-Series documentation, see the *Cisco UCS C-Series Servers Documentation Roadmap* available at the following URL: <http://www.cisco.com/go/unifiedcomputing/c-series-doc>.

For information on supported firmware versions and supported UCS Manager versions for the rack servers that are integrated with the UCS Manager for management, refer to [Release Bundle Contents for Cisco UCS Software](#).

Other Documentation Resources

Follow [Cisco UCS Docs on Twitter](#) to receive document update notifications.

Documentation Feedback

To provide technical feedback on this document, or to report an error or omission, please send your comments to ucs-docfeedback@cisco.com. We appreciate your feedback.



CHAPTER

1

Overview

- [Overview, page 1](#)
- [Cisco UCS Central User Documentation Reference, page 1](#)

Overview

This guide provides an overview of the Cisco Unified Computing System (Cisco UCS) and its key components-Cisco UCS Manager, and Cisco UCS Central.

Cisco UCS Central User Documentation Reference

The Cisco UCS Central following use case-based documents to understand and configure Cisco UCS Central:

| Guide | Description |
|-----------------------------------------------------------|--------------------------------------------------------------------------------------------------------------------------------------------------------------------------------------------------------------------------------------|
| Cisco UCS Central Getting Started Guide | Provides a brief introduction to the Cisco UCS infrastructure, Cisco UCS Manager, and Cisco UCS Central. Includes an overview of the HTML5 UI, how to register Cisco UCS domains in Cisco UCS Central, and how to activate licenses. |
| Cisco UCS Central Administration Guide | Provides information on administrative tasks, such as user management, communication, firmware management, backup management, and Smart Call Home. |
| Cisco UCS Central Authentication Guide | Provides information on authentication tasks, such as passwords, users and roles, RBAC, TACACS+, RADIUS, LDAP, and SNMP. |
| Cisco UCS Central Server Management Guide | Provides information on server management, such as equipment policies, physical inventory, service profiles and templates, server pools, server boot, and server policies. |

| Guide | Description |
|------------------------------------------------------------|------------------------------------------------------------------------------------------------------------------------------------------------------------------------------------------------------|
| Cisco UCS Central Storage Management Guide | Provides information on storage management, such as ports and port channels, VSAN and vHBA management, storage pools, storage policies, storage profiles, disk groups, and disk group configuration. |
| Cisco UCS Central Network Management Guide | Provides information on network management, such as ports and port channels, VLAN and vNIC management, network pools, and network policies. |
| Cisco UCS Central Operations Guide | Best practices for setting up, configuring, and managing domain groups for small, medium and large deployments. |
| Cisco UCS Central Troubleshooting Guide | Provides help for common issues in Cisco UCS Central. |



CHAPTER 2

Introduction to Cisco Unified Computing System Infrastructure

- [Cisco Unified Computing System Overview, page 3](#)
- [Cisco UCS Manager Overview, page 5](#)

Cisco Unified Computing System Overview

Figure 1: Cisco UCS Architecture

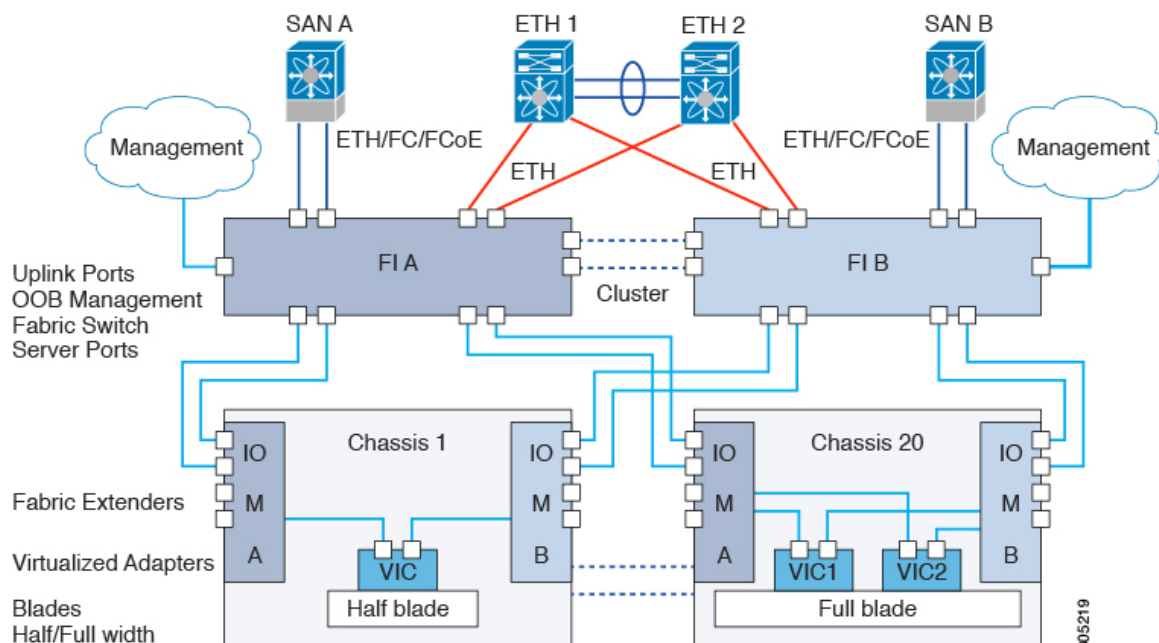

Cisco UCS has a unique architecture that integrates compute, data network access, and storage network access into a common set of components under a single-pane-of-glass management interface.

Cisco UCS fuses access layer networking and servers. This high-performance, next-generation server system provides a data center with a high degree of workload agility and scalability. The hardware and software components support Cisco's unified fabric, which runs multiple types of data center traffic over a single converged network adapter.

Architectural Simplification

The simplified architecture of Cisco UCS reduces the number of required devices and centralizes switching resources. By eliminating switching inside a chassis, network access-layer fragmentation is significantly reduced. Cisco UCS implements Cisco unified fabric within racks and groups of racks, supporting Ethernet and Fibre Channel protocols over 10 Gigabit Cisco Data Center Ethernet and Fibre Channel over Ethernet (FCoE) links. This radical simplification reduces the number of switches, cables, adapters, and management points by up to two-thirds. All devices in a Cisco UCS domain remain under a single management domain, which remains highly available through the use of redundant components.

High Availability

The management and data plane of Cisco UCS is designed for high availability and redundant access layer fabric interconnects. In addition, Cisco UCS supports existing high availability and disaster recovery solutions for the data center, such as data replication and application-level clustering technologies.

Scalability

A single Cisco UCS domain supports multiple chassis and their servers, all of which are administered through one Cisco UCS Manager. For more detailed information about the scalability, speak to your Cisco representative.

Flexibility

A Cisco UCS domain allows you to quickly align computing resources in the data center with rapidly changing business requirements. This built-in flexibility is determined by whether you choose to fully implement the stateless computing feature. Pools of servers and other system resources can be applied as necessary to respond to workload fluctuations, support new applications, scale existing software and business services, and accommodate both scheduled and unscheduled downtime. Server identity can be abstracted into a mobile service profile that can be moved from server to server with minimal downtime and no need for additional network configuration. With this level of flexibility, you can quickly and easily scale server capacity without having to change the server identity or reconfigure the server, LAN, or SAN. During a maintenance window, you can quickly do the following:

- Deploy new servers to meet unexpected workload demand and rebalance resources and traffic.
- Shut down an application, such as a database management system, on one server and then boot it up again on another server with increased I/O capacity and memory resources.

Optimized for Server Virtualization

Cisco UCS has been optimized to implement VM-FEX technology. This technology provides improved support for server virtualization, including better policy-based configuration and security, conformance with a company's operational model, and accommodation for VMware's VMotion.

Cisco UCS Manager Overview

Cisco UCS Manager is embedded software that resides on the fabric interconnects, providing complete configuration and management capabilities for all of the components in the Cisco UCS system. This configuration information is replicated between the two fabric interconnects, providing a highly available solution for this critical function. The most common way to access UCS Manager for simple tasks is to use a Web browser to open the Java-based GUI. For command-line or programmatic operations against the system, a command-line interface (CLI) and an XML API are also included with the system.

The Cisco UCS Manager GUI provides role-based access control (RBAC) to allow multiple levels of users granular administrative rights to system objects. Users can be restricted to certain portions of the system based on locale, which corresponds to an optional organizational structure that can be created within the system. Users can also be classified based on their access levels or areas of expertise, such as “Storage Administrator,” “Server Equipment Administrator,” or “Read-Only”. RBAC allows the comprehensive capabilities of the Cisco UCS Manager GUI to be properly shared across multiple individuals or teams within your organization in a flexible, secure manner.

Cisco UCS Manager provides unified, embedded management of all software and hardware components. Every instance of Cisco UCS Manager and all of the components managed by it form a domain. For organizations that deploy multiple Cisco UCS domains, Cisco UCS Central software provides a centralized user interface that allows you to manage multiple, globally distributed Cisco UCS domains with thousands of servers. Cisco UCS Central integrates with Cisco UCS Manager and utilizes it to provide global configuration capabilities for pools, policies, and firmware.



Introduction to Cisco UCS Central

- [Introducing Cisco UCS Central, page 7](#)

Introducing Cisco UCS Central

Cisco UCS Central provides scalable management solution for growing Cisco UCS environment. Cisco UCS Central simplifies the management of multiple Cisco UCS domains from a single management point through standardization, global policies and global ID pools. Cisco UCS Central does not replace Cisco UCS Manager, which is the policy driven management for single UCS domain. Instead Cisco UCS Central focuses on managing and monitoring the UCS domains on a global level, across multiple individual Cisco UCS Classic and Mini management domains worldwide.

Cisco UCS Central enables you to manage individual or groups of classic, mini or mixed Cisco UCS domains with the following:

- Centralized Inventory of all Cisco UCS components for a definitive view of the entire infrastructure and simplified integration with current Information Technology Infrastructure Library (ITIL) processes.
- Centralized, policy-based firmware upgrades that can be applied globally or selectively through automated schedules or as business workloads demand
- Global ID pooling to eliminate identifier conflicts
- Global administrative policies that enable both global and local management of the Cisco UCS domains
- An XML API, building on the Cisco UCS Manager XML API for easy integration into higher-level data center management frameworks
- Remote management to manage various end points in registered Cisco UCS domains

Cisco UCS Central does not reduce or change any local management capabilities of Cisco UCS Manager, such as its API. This allows you to continue using Cisco UCS Manager the same way as when you did not have Cisco UCS Central, and also allows all existing third party integrations to continue to operate without change.

Cisco UCS Central Features

The following table provides a list of features with brief description on the management capabilities of Cisco UCS Central:

Note

For a full list of new features, see the [Release Notes for Cisco UCS Central](#).

| Feature | Description |
|---------------------------------------------|------------------------------------------------------------------------------------------------------------------------------------------------------------------------------------------------------------------------------------------------------------------------------------------------------------------------------------------------------------------------------------------------------------------------------------------------------------------------------------------------------------------------|
| Centralized inventory | Cisco UCS Central automatically aggregates a global inventory of all registered Cisco UCS components, organized by domain, with customizable refresh schedules and provides even easier integration with ITIL processes, with direct access to the inventory through an XML interface. |
| Centralized fault summary | Cisco UCS Central enables you to view the status of all Cisco UCS infrastructure on the global fault summary panel, with a fault summary organized by domain and fault type. Also provides you the ability to view individual Cisco UCS Manager domains for greater fault detail and more rapid problem resolution. Drilling down on a fault launches the UCS Manager in context for a seamlessly integrated experience. |
| Centralized, policy-based firmware upgrades | You can download firmware updates automatically from the Cisco.com to a firmware library within Cisco UCS Central. Then schedule automated firmware updates, globally or selectively, based on your business requirements. Managing firmware centrally ensures compliance with IT standards and makes reprovisioning of resources a point-and-click operation. |
| Global ID pools | Cisco UCS Central eliminates identifier conflicts and ensures portability of software licenses. You are able to centralize the sourcing of all IDs, such as universal user IDs (UUIDs), MAC addresses, IP addresses, and worldwide names (WWNs), from global pools and gain real-time ID use summaries. Centralizing server identifier information makes it simple to move a server identifier between Cisco UCS domains anywhere in the world and reboot an existing workload to run on the new server. |
| Domain groups | Cisco UCS Central simplifies policy management by providing options to create domain groups and subgroups. A domain group is an arbitrary grouping of Cisco UCS domains that can be used to group systems into geographical or organizational groups. Each domain group can have up to five levels of domain sub groups. This provides you the ability to manage policy exceptions when administering large numbers of Cisco UCS domains. Each sub group has a hierarchical relationship with the parent domain group. |

| Feature | Description |
|---------------------------------------|------------------------------------------------------------------------------------------------------------------------------------------------------------------------------------------------------------------------------------------------------------------------------------------------------------------------------------|
| Global administrative policies | Cisco UCS Central helps you to ensure compliance and staff efficiency with global administrative policies. The global policies are defined at the domain group level and can manage anything in the infrastructure, from date and time and user authentication to equipment power and system event log (SEL) policies. |
| Global service profiles and templates | Global service profiles and templates in Cisco UCS Central enables fast and simplified infrastructure deployment and provides consistency of configurations throughout the enterprise. This feature enables global bare-metal workload mobility very similar to how hypervisor enables virtualized workload mobility. |
| Backup | Cisco UCS Central provides an automatic backup facility that enables quick and efficient backing up the configuration information of the registered Cisco UCS domains and the UCS Central configuration. |
| High availability | As with all Cisco UCS solutions, Cisco UCS Central is designed for no single point of failure. High availability for Cisco UCS Central Software allows organizations to run Cisco UCS Central using an active-standby model with a heartbeat that automatically fails over if the active Cisco UCS Central does not respond. |
| XML API | Cisco UCS Central, just like Cisco UCS Manager, has a high-level industry-standard XML API for interfacing with existing management frameworks and orchestration tools. The XML API for Cisco UCS Central Software is similar to the XML API for Cisco UCS Manager, making integration with high-level managers very fast. |
| Remote Management | Cisco UCS Central enables you to manage various end points in the registered Cisco UCS domains from one management point. You can manage chassis, servers, fabric interconnects, and fabric extenders from Cisco UCS Central GUI or CLI. You can also access tech support files for registered UCS domains from Cisco UCS Central. |

Overview of Cisco UCS Central HTML 5 UI

Cisco UCS Central HTML5 based user interface provides flexibility and task based usability for your management purposes.

The dashboard provides a quick overview of components in the system. You can pin the components you use frequently and customize the dashboard to suit your operational requirements. You can click on any object on the dashboard to go to the related page in the system.

Using the HTML5 UI

Dashboard

You can pin dashboard widgets and customize the dashboard based on your operational requirements. The following describes the basic dashboard structure, and the navigation icons, for performing management tasks:

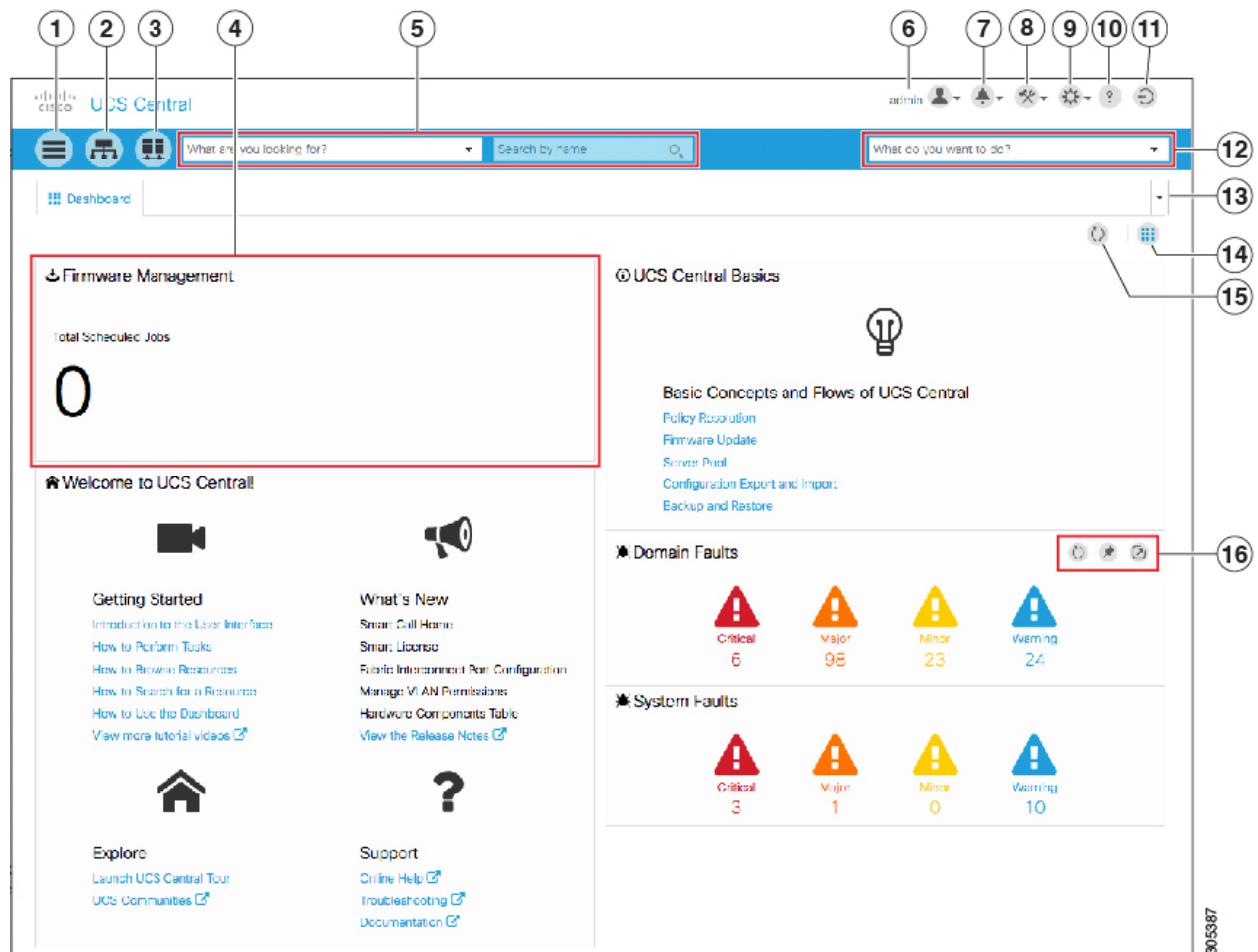

| Item | Description |
|------|-------------------------------------------------------------------------------------------------------------------------------------------------------------------------------------------------------------------------------------------------------------------------------------------------------------------------------------------------------------------|
| 1 | Browse Tables icon. Click to display physical and logical inventory-related entities in the system such as: Domains, Fabric Interconnects, Servers, Chassis, FEX, Hardware Components, vLANs, vSANs, Service Profiles, Templates, Pools, Policies, Schedules, ID Universe, and Tags. Click any of these entities to launch related pages and view details. |
| 2 | Organization navigation icon. Click to display org root and other sub organizations in the system. You can click the root, or any suborganization, to launch the details page for a selected organization. |

| Item | Description |
|------|----------------------------------------------------------------------------------------------------------------------------------------------------------------------------------------------------------------------------------------------------------------------------------------------------------------------------------------------------------------------------------------------------------|
| 3 | Domain group navigation icon. Click to display domain group root and other domain groups in the system. You can click a domain group to launch the details page. |
| 4 | Dashboard widget. You can pin any widget on this dashboard. When you mouse over on the widget, other options are enabled on widget's menu bar. |
| 5 | Search bar. What are you looking for? You can do the following: <ul style="list-style-type: none"> • Select the entity type to search for any entity in the system by name. Empty search string returns all entities. • Filter search results by location and status when applicable. • Click an entity in the search results to open the details on a new page. |
| 6 | Profile Configuration icon. Click to launch User Preferences and Change Password . From here you can Change Password , Restore Dashboard Defaults , and Show First Launch Experience . |
| 7 | System Alerts icon. Click to display and navigate to Pending Activities , System Faults , Domain Faults , Events , Audit Logs , Core Dumps , and Internal Services . |
| 8 | System Tools icon. Click to display and navigate to Firmware Management , Backup & Restore , Export & Import , Tech Support , Image Library , Domain Management , Hardware Compatibility Reports , Unified KVM Launcher , Active Sessions , and Start Logging Session . |
| 9 | System Configuration icon. Click to display and navigate to System Profiles , System Policies , Users , Authentication , SNMP , Smart Call Home , and Licenses . |
| 10 | Help icon. Click to access online help. |
| 11 | Log out icon. Click to log out from the active Cisco UCS Central session. |
| 12 | Actions bar. What do you want to do? You can Create, Schedule, Install, Export, and Import from here: <ul style="list-style-type: none"> • Click the drop-down arrow to display available actions. • Select a task, or type the task into the actions bar. • Launch the dialog box to perform the task. |
| 13 | Tab navigator. Allows you to navigate through the open tabs, or close all tabs at once. |

| Item | Description |
|------|-----------------------------------------------------------------------------------------------------------------------------------------------------------------------------------------------------------------------------------------------------------------------------------------------|
| 14 | Dashboard widgets library icon. Click to view available widgets. Click the widget to pin it to the dashboard. |
| 15 | Refresh icon. Click to refresh the information in all pinned widgets or table pages. |
| 16 | Widget menu. From within any widget on the dashboard you can do the following: <ul style="list-style-type: none"> • Refresh the displayed information for this widget. • Unpin this widget from the dashboard. • Launch the details page for this operation. |

Dashboard Widgets

Dashboard widgets allow you to customize the dashboard based on your operational requirements. Cisco UCS Central contains the following types of widgets:

Default Widgets

Default widgets are listed in the widgets library on the dashboard. Click the widgets library to pin the widget to the dashboard. The widgets library includes the following widgets:

- **Welcome to UCS Central!**—Displays introductory links and videos to get you started with Cisco UCS Central.
- **UCS Central Basics**— Displays basic concepts and flows for Cisco UCS Central.
- **Licenses**—Displays the total number of licenses and their status.
- **Backup & Restore**—Displays the current backup and restore status.
- **Config Export & Import**—Displays the current config export and import status.
- **Firmware Management**—Displays the total number of scheduled Firmware update jobs.
- **Inventory Status**—Displays the number of domains, FIs, servers, chassis, and FEX, as well as the overall status.
- **ID Universe**—Displays the number of IDs that are available or in conflict.
- **System Faults**—Displays the number of system faults with the top four severities.
Click the Expand icon to view the Faults Log page for all system faults. Click on a fault icon to view the system faults with the selected severity pre-selected.
- **Domain Faults**—Displays the number of domain faults with the top four severities.
Click the Expand icon to view the Faults Log page for all domain faults. Click on a fault icon to view the domain faults with the selected severity pre-selected.
- **Pending Activities**—Displays Pending activities. Some may need user acknowledgment.

- **Domains**—Displays current number of domains registered with Cisco UCS Central.

Table Summary Widgets

Table summary widgets displays the total number of items and the status for the following:

- **Domains**
- **Fabric Interconnects**
- **Servers**
- **Chassis**
- **FEX**
- **Service Profiles**

Up to two status bars can be displayed, with the top four errors displayed in each status bar.

Click the Expand icon to view the full table.

Detailed Instance Summary Widgets

Detailed instance summary widgets display the overall status and fault summary. Click the pin icon to create a widget for the following instances:

- Domain
- Domain Group
- Organization
- Fabric Interconnect
- Server
- Chassis
- FEX
- Service Profile

Click the Expand icon to view the full instance page. Click on a fault icon to view a faults window with the selected severity pre-selected.

Instance Shortcut Widgets

Shortcut widgets create a read-only link to a particular instance of a policy or template. Click the pin icon on an instance to create the widget.

Adding Table Summary Widgets to the Dashboard

Procedure

- Step 1** Click the **Search** icon and choose one of the following:

- **Domains**
- **Fabric Interconnects**
- **Servers**
- **Chassis**
- **FEX**
- **Service Profiles**

Step 2 On the table page that displays, click the **Pin** icon.

Step 3 Click the **Dashboard** link to view the new widget.

Adding Instance Summary Widgets to the Dashboard

Procedure

Step 1 Click the **Search** icon and select one of the following:

- **Domains**
- **Fabric Interconnects**
- **Servers**
- **Chassis**
- **FEX**
- **Service Profiles**

Step 2 Click on an instance.

Step 3 On the instance page that displays, click the **Pin** icon.

Step 4 Click the **Dashboard** link to view the new widget.

Tab Navigator

The tab navigator appears on all screens, and allows you to navigate quickly through the tabs that you have opened. You can also close all tabs at once.







Using the Tab Navigator











Procedure











-
- Step 1** On the tab bar, click the drop-down on the far right.
A list of all currently opened tabs is displayed.
- Step 2** Select the tab that you want to navigate to, or select **Close All Tabs** to close all of the tabs.
- Note** You cannot close the dashboard tab.
-

Common User Interface Options

The following table describes user interface options:

| Icon | Label | Description |
|-------------------------------------------------------------------------------------|--------------------|-------------------------------------------------------------------------|
|  | Acknowledge | Acknowledge the changes most recently made. |
|  | Acknowledge reboot | Grant permission for Cisco UCS Central to reboot the selected hardware. |
|  | Add | Add the settings selected. |
|  | Apply | Apply the settings that you configured. |
|  | Browse Tables | Display physical and logical inventory entities in the system. |
|  | Dashboard | Access to the Dashboard widgets. |

| Icon | Label | Description |
|-------------------------------------------------------------------------------------|-------------------------------------|------------------------------------------------------------------------------------------------------|
|  | Delete | Delete selected items. |
|  | Domain Group Navigation | Search through all of the registered domains. |
|  | Download and Import Selected Images | Download and import selected images from the Image Library. |
|  | Download CSV file | Download data in table as a *.csv (comma delineated) file. |
|  | Download PDF file | Download data in table as a *.pdf (Adobe PDF) file. |
|  | Download XLS file | Download data in table as an *.xls (Microsoft Excel) file. |
|  | Dual Table View | Splits the table view into two views. |
|  | Edit | Edit the item selected. |
|  | Launch | Launch the submenu for the selected item. |
|  | Organization Navigation | Access to organizations and their service profiles, templates, pools, policies, and permitted vLANs. |

| Icon | Label | Description |
|-------------------------------------------------------------------------------------|-----------------------|-------------------------------------------------------------------------------------------------------------------------------------------------------|
|  | Pin | Pin the widget to the dashboard. |
|  | Profile Configuration | Configure user settings, such as password and preferences. |
|  | Register Domain | Register a Cisco UCS Manager domain with Cisco UCS Central. |
|  | Re-run report | Re-run the Hardware Compatibility List report. |
|  | Reset | Reset service profile assigned IDs manually. |
|  | Share tab | Copy a service profile's URL. When you send the link to another user, it opens to the same view. The other user does not have to search for the view. |
|  | System Alerts | Access to system alerts menu, logs, faults, core dumps, internal services, events, and pending activities. |
|  | System Configuration | Access to the system configuration menu when on the system level. In other views, configuration menu is contextual. |
|  | Tag | Tag items to assign them to groups for specific functions. |
|  | Tools | Access to the system tools menu when on the system level. In other views, tools menu is contextual. |
|  | Unregister Domain | Unregister a Cisco UCS Manager domain from Cisco UCS Central. |

| Icon | Label | Description |
|-----------------------------------------------------------------------------------|-------------|--------------------------------------------------------|
|  | Usage Table | Opens a table to show data associated with the object. |

Behavior and Design Changes in HTML5 UI

Deprecation Announcement for Cisco UCS M-Series Modular Servers

Cisco UCS M-Series Modular Servers have been deprecated and will not be supported in Cisco UCS Central release 1.5.

Feature Support

RDM-based shared storage for Cisco UCS Central HA configurations are no longer supported with Cisco UCS Central release 1.5.

The following features that are available in the older flash-based user interface are not supported in the HTML5 user interface at this time:

- Policy Import
- Threshold Policy
- Statistics



Note

Any functionality introduced in Cisco UCS Central release 1.4(1a) and newer releases will be available in the HTML 5 user interface only.

Behavior Changes Based on Design

- You must create the global service profile template before you can create a service profile.
- vNIC and vHBA Placement is now referred to as Interface Placement.
- Registration Policy is now referred to as Domain Group Qualification Policy.
- ID Range Qualification Policy is now referred to as ID Range Access Control Policy.
- There are no qualified IP addresses for ID Range Access Control Policy.
- Only the configuration export (all-config) and backup (full-state) options are used in Cisco UCS Central. Other backup types such as config logical and config system are not supported.



Working with Cisco UCS Manager

- [Cisco UCS Domains and Cisco UCS Central, page 19](#)
- [Policies in Cisco UCS Central and Cisco UCS Domains, page 24](#)
- [Domains and Domain Groups, page 31](#)
- [Domain Group Qualification Policy, page 33](#)
- [Organization, page 34](#)

Cisco UCS Domains and Cisco UCS Central

Cisco UCS Central provides centralized management capabilities to multiple Cisco UCS domains across one or more data centers. Cisco UCS Central works with Cisco UCS Manager to provide a scalable management solution for a growing Cisco UCS environment.

Cisco UCS Central does not reduce or change any local management capabilities of Cisco UCS Manager, such as its API. This allows you to continue using Cisco UCS Manager the same way you did before Cisco UCS Central. This also allows all existing third party integrations to continue to operate without change.

Registering Cisco UCS Domains

To manage Cisco UCS Manager through Cisco UCS Central, you must register the Cisco UCS domains in Cisco UCS Central. You can register a Cisco UCS domain as a part of a domain group or as an ungrouped domain. When you have a domain group, all registered domains in the domain group can share common policies and other configurations.

You can use a Fully Qualified Domain Name (FQDN) or IP address to register Cisco UCS domains in Cisco UCS Central.



Note

During the initial registration process with Cisco UCS Central, all of the active Cisco UCS Manager GUI sessions are terminated.

Before registering a domain in Cisco UCS Central, do the following:

- Configure an NTP server and the correct time zone in both Cisco UCS Manager and Cisco UCS Central to ensure that they are in sync. If the time and date in the Cisco UCS domain and Cisco UCS Central are out of sync, the registration might fail.
- Obtain the hostname or IP address of Cisco UCS Central. You cannot use the same hostname for both Cisco UCS Central and Cisco UCS Manager. For standalone mode, use individual VM IP address. If you plan to setup in cluster mode, use virtual IP address.



Note We recommend that you always register Cisco UCS domains using a Fully Qualified Domain Name (FQDN).

- Obtain the shared secret that you configured when you deployed Cisco UCS Central.



Note

- If you register Cisco UCS domains using a domain name, Cisco UCS Manager can gracefully move to a different IP address.

If you register a Cisco UCS domain in Cisco UCS Central using an IP address, you cannot change or swap the IP address used by Cisco UCS Manager. If you need to change or swap the IP address, you must contact Cisco TAC.

- You can register or un-register a Cisco UCS domain using Cisco UCS Manager GUI or CLI.
 - If Cisco UCS Central is deployed on RHEL 7.2 KVM, the first time you register a Cisco UCS domain, you must regenerate the certificate using the **set regenerate yes** command.
 - If the registered Cisco UCS domains have a latency of greater than 300ms for a round trip from Cisco UCS Central, there might be some performance implications for the Cisco UCS domains.
 - When you unregister a Cisco UCS domain from Cisco UCS Central the global service profiles become local service profiles in Cisco UCS Manager.
-



Warning

You must upgrade to Cisco UCS Manager Release 2.1(2) or greater before registering with Cisco UCS Central. If you try to register earlier versions of Cisco UCS Manager, the registration will fail.

Registering a Cisco UCS Domain in Cisco UCS Central

Before You Begin

Configure an NTP server and set the correct time zone in both Cisco UCS Manager and Cisco UCS Central.

To register using the Cisco UCS Central hostname, you must also configure a DNS server. The DNS record must be created properly, and the DNS configuration must be in place for both Cisco UCS Manager and Cisco UCS Central.

Procedure

- Step 1** In the **Actions** bar, type **Register Domain to UCS Central** and press Enter.
- Step 2** On the **Domain to UCS Central** dialog box, on the **Basic** tab, enter the Cisco UCS domain hostname or IP address, user name, and password.
- Step 3** Choose the network interface for Cisco UCS Central that supports the format you selected for the Cisco UCS domain.

The following combinations are supported:

| | Cisco UCS Central IPv4 | Cisco UCS Central IPv6 | Cisco UCS Central Hostname |
|----------------------------|------------------------|------------------------|----------------------------|
| Cisco UCS Manager IPv4 | Supported | Not supported | Not supported |
| Cisco UCS Manager IPv6 | Not supported | Supported | Supported |
| Cisco UCS Manager Hostname | Supported | Supported | Supported |

- Step 4** On the **Policy Resolution Control** tab, choose whether the policy resolution will occur in locally in Cisco UCS Manager, or be globally controlled by Cisco UCS Central.

Note The policy resolution options in Cisco UCS Central are not supported on all versions of Cisco UCS Manager. If your Cisco UCS Manager version is earlier than the earliest supported release, the policy resolution screen may display the value as global even if it is not applicable.

| Name | Earliest Supported Release | Description |
|----------------------------------------------|----------------------------|--------------------------------------------------------------------------------------------------------------------------------------------------------------------------------------------|
| Infrastructure & Catalog Firmware | 2.1(2) | Determines whether the Capability Catalog and infrastructure firmware policy are defined locally in Cisco UCS Manager or come from Cisco UCS Central. |
| Time Zone Management | 2.1(2) | Determines whether the time zone and NTP server settings are defined locally in Cisco UCS Manager or comes from Cisco UCS Central. |
| Communication Services | 2.1(2) | Determines whether HTTP, CIM XML, Telnet, SNMP, web session limits, and Management Interfaces Monitoring Policy settings are defined locally in Cisco UCS Manager or in Cisco UCS Central. |
| Global Fault Policy | 2.1(2) | Determines whether the Global Fault Policy is defined locally in Cisco UCS Manager or in Cisco UCS Central. |
| User Management | 2.1(2) | Determines whether authentication and native domains, LDAP, RADIUS, TACACS+, trusted points, locales, and user roles are defined locally in Cisco UCS Manager or in Cisco UCS Central. |

| Name | Earliest Supported Release | Description |
|-----------------------------------------------|----------------------------|-------------------------------------------------------------------------------------------------------------------------------------------------------|
| DNS Management | 2.1(2) | Determines whether DNS servers are defined locally in Cisco UCS Manager or in Cisco UCS Central. |
| Backup & Export Policies | 2.1(2) | Determines whether the Full State Backup Policy and All Configuration Export Policy are defined locally in Cisco UCS Manager or in Cisco UCS Central. |
| Monitoring | 2.1(2) | Determines whether Call Home, Syslog, and TFTP Core Exporter settings are defined locally in Cisco UCS Manager or in Cisco UCS Central. |
| SEL Policy | 2.1(2) | Determines whether the SEL Policy is defined locally in Cisco UCS Manager or in Cisco UCS Central. |
| Power Allocation Policy | 2.1(2) | Determines whether the Power Allocation Policy is defined locally in Cisco UCS Manager or in Cisco UCS Central. |
| Power Policy | 2.1(2) | Determines whether the Power Policy is defined locally in Cisco UCS Manager or in Cisco UCS Central. |
| Equipment Policy | 2.2(7) | Determines whether the Equipment Policy is defined locally in Cisco UCS Manager or in Cisco UCS Central. |
| Port Configuration | 2.2(7) | Determines whether port configuration is defined locally in Cisco UCS Manager or in Cisco UCS Central. |
| Quality of Service (QoS) Configuration | 2.2(7) | Determines whether QoS configuration is defined locally in Cisco UCS Manager or in Cisco UCS Central. |

Note The infrastructure and catalog firmware policy is set to local by default. All other policies are set to global.

Step 5 Click **Register**.

Domain Registration Management

On the Domain Management page, you can view the domain registrations and lost domains.

Domain Registrations

The **Domain Registrations** tab displays all Cisco UCS domains that you have attempted to register to Cisco UCS Central.

From this tab, you can do the following:

- Filter the Cisco UCS domains that are displayed.
- Delete Cisco UCS domains that failed to register.
- Retry the registration process.
- View the configuration status of the Cisco UCS domain.
- Unregister a successfully registered domain.

**Important**

We recommend that you contact Cisco TAC before attempting to unregister a Cisco UCS domain.

Lost Domains

The **Lost Domains** tab displays all Cisco UCS domains that have lost connectivity. These domains may or may not be listed as **Registered**. You can delete these domains.

Unregistering a Cisco UCS Domain in Cisco UCS Central

**Caution**

If you want to unregister any registered Cisco UCS Domain in a production system, contact Cisco Technical Support.

When you unregister a Cisco UCS Domain from Cisco UCS Central:

- You can no longer manage the service profiles, policies, and other configuration for the Cisco UCS Domain from Cisco UCS Central.
- All global service profiles and policies become local and continue to operate as local entities. When you reregister the domain, the service profiles and policies remain local.

**Note**

You can also choose to remove the service profiles and policies entirely.

In a case where you choose certain policies to be resolved locally using the Policy Resolution Control feature in Cisco UCS Central, or when a Cisco UCS Domain is unregistered from Cisco UCS Central, the global settings/unnamed policies (such as QoS Settings, Discovery policies) stay as previously configured. You must manually change the policy details to the desired state.

**Caution**

Unregistering a Cisco UCS Domain has serious implications. You must not unregister the Cisco UCS Domain unless you choose to permanently not manage it from Cisco UCS Central.

Procedure

- Step 1** Click the **System Tools** icon and select **Domain Management**.
- Step 2** On the **Domain Management** page, click the **Domain Registration** tab and choose the domain that you want to unregister.
- Step 3** Click the **Unregister Domain** icon.
- Step 4** Click **Unregister Domain** to continue.
- Step 5** Choose the cleanup mode that you want to use:
- **Deep Remove Global**—Removes all policies inherited from the global configuration.
 - **Localize Global**—Turns all global policies into local policies.
- Step 6** Click **Unregister Domain**.
-

Viewing Domain Registration Configuration Status

Procedure

- Step 1** Click the **System Tools** icon and choose **Domain Management**.
- Step 2** Locate the domain that you want to view, and click **Configuration Status**.
The **Domain Registrations Configuration Status** page displays the status of the registration.
- Step 3** Click **Close** to close the window.
-

Policies in Cisco UCS Central and Cisco UCS Domains

You can create and manage global policies in Cisco UCS Central and include them in service profiles or service profile templates for one or more Cisco UCS domains. The service profiles and service profile templates that include global policies can be either of the following:

- Local service profiles or service profile templates that are created and managed by Cisco UCS Manager in one Cisco UCS domain. You can only associate local service profiles with servers in that domain. When you include a global policy in a local service profile, Cisco UCS Manager makes a local read-only copy of that policy.
- Global service profiles or service profile templates that are created and managed by Cisco UCS Central. You can associate global service profiles with servers in one or more registered Cisco UCS domains.

You can only make changes to global policies in Cisco UCS Central. Those changes affect all service profiles and service profile templates that include the global policy. All global policies are read-only in Cisco UCS Manager.

You can configure all operational policies under a domain group using IPv6 addresses. These policies are located in the **Operations Management** tab of the Cisco UCS Central GUI.

This feature helps the Cisco UCS Manager to use an IPv6 address while importing these policies from Cisco UCS Central.

Policy Resolution between Cisco UCS Manager and Cisco UCS Central

Policy Resolution Control

For each Cisco UCS domain that you register with Cisco UCS Central, you can choose which application will manage certain policies and configuration settings. This policy resolution does not have to be the same for every Cisco UCS domain that you register with the same Cisco UCS Central.

You have the following options for resolving these policies and configuration settings:

- **Local**—The policy or configuration is determined and managed by Cisco UCS Manager.
- **Global**—The policy or configuration is determined and managed by Cisco UCS Central.

The following table contains a list of the policies and configuration settings that you can choose to have managed by either Cisco UCS Manager or Cisco UCS Central:



Note

The policy resolution options in Cisco UCS Central are not supported on all versions of Cisco UCS Manager. If your Cisco UCS Manager version is earlier than the earliest supported release, the policy resolution screen may display the value as global even if it is not applicable.

In a case where you choose certain policies to be resolved locally using the Policy Resolution Control feature in Cisco UCS Central, or when a Cisco UCS Domain is unregistered from Cisco UCS Central, the global settings/unnamed policies (such as QoS Settings, Discovery policies) stay as previously configured. You must manually change the policy details to the desired state.



Caution

Unregistering a Cisco UCS Domain has serious implications. You must not unregister the Cisco UCS Domain unless you choose to permanently not manage it from Cisco UCS Central.

| Name | Earliest Supported Release | Description |
|----------------------------------------------|----------------------------|-------------------------------------------------------------------------------------------------------------------------------------------------------|
| Infrastructure & Catalog Firmware | 2.1(2) | Determines whether the Capability Catalog and infrastructure firmware policy are defined locally in Cisco UCS Manager or come from Cisco UCS Central. |
| Time Zone Management | 2.1(2) | Determines whether the time zone and NTP server settings are defined locally in Cisco UCS Manager or comes from Cisco UCS Central. |

| Name | Earliest Supported Release | Description |
|-----------------------------------------------|-----------------------------------|--------------------------------------------------------------------------------------------------------------------------------------------------------------------------------------------|
| Communication Services | 2.1(2) | Determines whether HTTP, CIM XML, Telnet, SNMP, web session limits, and Management Interfaces Monitoring Policy settings are defined locally in Cisco UCS Manager or in Cisco UCS Central. |
| Global Fault Policy | 2.1(2) | Determines whether the Global Fault Policy is defined locally in Cisco UCS Manager or in Cisco UCS Central. |
| User Management | 2.1(2) | Determines whether authentication and native domains, LDAP, RADIUS, TACACS+, trusted points, locales, and user roles are defined locally in Cisco UCS Manager or in Cisco UCS Central. |
| DNS Management | 2.1(2) | Determines whether DNS servers are defined locally in Cisco UCS Manager or in Cisco UCS Central. |
| Backup & Export Policies | 2.1(2) | Determines whether the Full State Backup Policy and All Configuration Export Policy are defined locally in Cisco UCS Manager or in Cisco UCS Central. |
| Monitoring | 2.1(2) | Determines whether Call Home, Syslog, and TFTP Core Exporter settings are defined locally in Cisco UCS Manager or in Cisco UCS Central. |
| SEL Policy | 2.1(2) | Determines whether the SEL Policy is defined locally in Cisco UCS Manager or in Cisco UCS Central. |
| Power Allocation Policy | 2.1(2) | Determines whether the Power Allocation Policy is defined locally in Cisco UCS Manager or in Cisco UCS Central. |
| Power Policy | 2.1(2) | Determines whether the Power Policy is defined locally in Cisco UCS Manager or in Cisco UCS Central. |
| Equipment Policy | 2.2(7) | Determines whether the Equipment Policy is defined locally in Cisco UCS Manager or in Cisco UCS Central. |
| Port Configuration | 2.2(7) | Determines whether port configuration is defined locally in Cisco UCS Manager or in Cisco UCS Central. |
| Quality of Service (QoS) Configuration | 2.2(7) | Determines whether QoS configuration is defined locally in Cisco UCS Manager or in Cisco UCS Central. |

Policies

You can assign the following policies to a domain:

- QoS System Class
- In-Band Policy

Consequences of Policy Resolution Changes

When you register a Cisco UCS domain, you configure policies for local or global resolution. The behavior that occurs when the Cisco UCS domain is registered or when that registration or configuration changes, depends upon several factors, including whether a domain group has been assigned or not.

The following table describes the policy resolution behavior you can expect for each type of policy.

| Policies and Configuration | Policy Source | | Behavior in Cisco UCS Manager on Registration with Cisco UCS Central | | Behavior in Cisco UCS Manager when Registration Changed | |
|-----------------------------------------|-------------------------------|-----------------------|----------------------------------------------------------------------|-----------------------|---------------------------------------------------------|-------------------------------------|
| | Cisco UCS Central | Cisco UCS Manager | Domain Group Unassigned | Domain Group Assigned | Unassigned from Domain Group | Deregistered from Cisco UCS Central |
| Call Home | N/A Cisco UCS Manager only | Assigned domain group | Local | Local/Remote | Retains last known policy state | Converted to a local policy |
| SNMP configuration | N/A Cisco UCS Manager only | Assigned domain group | Local | Local/Remote | Retains last known policy state | Converted to a local policy |
| HTTP | N/A Cisco UCS Manager only | Assigned domain group | Local | Local/Remote | Retains last known policy state | Converted to a local policy |
| Telnet | N/A Cisco UCS Manager only | Assigned domain group | Local | Local/Remote | Retains last known policy state | Converted to a local policy |
| CIM XML | N/A Cisco UCS Manager only | Assigned domain group | Local | Local/Remote | Retains last known policy state | Converted to a local policy |
| Management interfaces monitoring policy | N/A Cisco UCS Manager only | Assigned domain group | Local | Local/Remote | Retains last known policy state | Converted to a local policy |
| Power allocation policy | N/A Cisco UCS Manager only | Assigned domain group | Local | Local/Remote | Retains last known policy state | Converted to a local policy |

| Policies and Configuration | Policy Source | | Behavior in Cisco UCS Manager on Registration with Cisco UCS Central | | Behavior in Cisco UCS Manager when Registration Changed | |
|---------------------------------------------|-------------------------------|-----------------------|----------------------------------------------------------------------|-----------------------|---------------------------------------------------------|-------------------------------------|
| | Cisco UCS Central | Cisco UCS Manager | Domain Group Unassigned | Domain Group Assigned | Unassigned from Domain Group | Deregistered from Cisco UCS Central |
| Power policy (also known as the PSU policy) | N/A Cisco UCS Manager only | Assigned domain group | Local | Local/Remote | Retains last known policy state | Converted to a local policy |
| SEL policy | N/A Cisco UCS Manager only | Assigned domain group | Local | Local/Remote | Retains last known policy state | Converted to a local policy |
| Authentication Domains | N/A Cisco UCS Manager only | Assigned domain group | Local | Local/Remote | Retains last known policy state | Converted to a local policy |
| LDAP | Domain group root | Assigned domain group | Local | Local/Remote | Retains last known policy state | Converted to a local policy |
| LDAP provider groups and group maps | N/A Cisco UCS Manager only | Assigned domain group | Local | Local/Remote | Retains last known policy state | Converted to a local policy |
| TACACS, including provider groups | N/A Cisco UCS Manager only | Assigned domain group | Local | Local/Remote | Retains last known policy state | Converted to a local policy |
| RADIUS, including provider groups | N/A Cisco UCS Manager only | Assigned domain group | Local | Local/Remote | Retains last known policy state | Converted to a local policy |
| SSH (Read-only) | Domain group root | Assigned domain group | Local | Local/Remote | Retains last known policy state | Converted to a local policy |
| DNS | Domain group root | Assigned domain group | Local | Local/Remote | Retains last known policy state | Converted to a local policy |
| Time zone | Domain group root | Assigned domain group | Local | Local/Remote | Retains last known policy state | Converted to a local policy |

| Policies and Configuration | Policy Source | | Behavior in Cisco UCS Manager on Registration with Cisco UCS Central | | Behavior in Cisco UCS Manager when Registration Changed | |
|-----------------------------|-------------------|-----------------------|----------------------------------------------------------------------|----------------------------------------|---------------------------------------------------------|-------------------------------------|
| | Cisco UCS Central | Cisco UCS Manager | Domain Group Unassigned | Domain Group Assigned | Unassigned from Domain Group | Deregistered from Cisco UCS Central |
| Web Sessions | Domain group root | Assigned domain group | Local | Local/Remote | Retains last known policy state | Converted to a local policy |
| Fault | Domain group root | Assigned domain group | Local | Local/Remote | Retains last known policy state | Converted to a local policy |
| Core Export | Domain group root | Assigned domain group | Local | Local/Remote | Retains last known policy state | Converted to a local policy |
| Syslog | Domain group root | Assigned domain group | Local | Local/Remote | Retains last known policy state | Converted to a local policy |
| Global Backup/Export Policy | Domain group root | Assigned domain group | Local | Local/Remote | Retains last known policy state | Converted to a local policy |
| Default Authentication | Domain group root | Assigned domain group | Local | Local/Remote | Retains last known policy state | Converted to a local policy |
| Console Authentication | Domain group root | Assigned domain group | Local | Can be local or remote | Retains last known policy state | Converted to a local policy |
| Roles | Domain group root | Assigned domain group | Local | Local/Combine (Remote replacing Local) | Deletes remote policies | Converted to a local policy |
| Locales - Org Locales | Domain group root | Assigned domain group | Local | Local/Combine (Remote replacing Local) | Deletes remote policies | Converted to a local policy |
| Trust Points | Domain group root | Assigned domain group | Local | Local/Combine (Remote replacing Local) | Deletes remote policies | Converted to a local policy |
| Firmware Download Policy | Domain group root | N/A | N/A | N/A | N/A | N/A |

| Policies and Configuration | Policy Source | | Behavior in Cisco UCS Manager on Registration with Cisco UCS Central | | Behavior in Cisco UCS Manager when Registration Changed | |
|-------------------------------------------------|-------------------|-----------------------|----------------------------------------------------------------------------------------------|----------------------------------------------------------------------------------------------|---------------------------------------------------------|-------------------------------------|
| | Cisco UCS Central | Cisco UCS Manager | Domain Group Unassigned | Domain Group Assigned | Unassigned from Domain Group | Deregistered from Cisco UCS Central |
| ID Soaking Policy | Domain group root | N/A | N/A | N/A | N/A | N/A |
| Locales - Domain Group Locales | Domain group root | N/A | N/A | N/A | N/A | N/A |
| Infrastructure Firmware Packs | N/A | Assigned domain group | Local | Local/Remote (if Remote exists) | Retains last known policy state | Converted to a local policy |
| Catalog | N/A | Assigned domain group | Local | Local/Remote (if Remote exists) | Retains last known policy state | Converted to a local policy |
| Maintenance Policy Schedule Host Firmware Packs | N/A | Assigned domain group | See Consequences of Service Profile Changes on Policy Resolution, on page 31 | See Consequences of Service Profile Changes on Policy Resolution, on page 31 | Deletes remote policies | Converted to a local policy |
| Maintenance Policy Schedule Host Firmware Packs | N/A | Assigned domain group | See Consequences of Service Profile Changes on Policy Resolution, on page 31 | See Consequences of Service Profile Changes on Policy Resolution, on page 31 | Deletes remote policies | Converted to a local policy |
| Maintenance Policy Schedule Host Firmware Packs | N/A | Assigned domain group | See Consequences of Service Profile Changes on Policy Resolution, on page 31 | See Consequences of Service Profile Changes on Policy Resolution, on page 31 | Deletes remote policies | Converted to a local policy |

Consequences of Service Profile Changes on Policy Resolution

For certain policies, the policy resolution behavior is also affected by whether or not one or more service profiles that include that policy have been updated.

The following table describes the policy resolution behavior you can expect for those policies.

| Policy | Behavior in Cisco UCS Manager on Registration with Cisco UCS Central | | Domain Group Assigned after Registration with Cisco UCS Central |
|-----------------------------------------------------------------------------------------------------------------------------------------------------------------------------------------------------------------|----------------------------------------------------------------------|--------------------------------------------------------------------------|-----------------------------------------------------------------|
| | Domain Group Unassigned / Domain Group Assigned | | |
| | Service Profile not Modified | Service Profile Modified | |
| Maintenance Policy Note If you are using a global maintenance policy in a local service profile, all pending activities must be acknowledged on the Cisco UCS Central Pending Activities page. | Local | Local, but any "default" policies are updated on domain group assignment | Local/Remote (if resolved to "default" post registration) |
| Schedule | Local | Local, but any "default" policies are updated on domain group assignment | Local/Remote (if resolved to "default" post registration) |
| Host Firmware Packages | Local | Local, but any "default" policies are updated on domain group assignment | Local/Remote (if resolved to "default" post registration) |

Domains and Domain Groups

When you register a Cisco UCS Manager instance in Cisco UCS Central, that instance becomes an ungrouped domain in Cisco UCS Central. You must assign this domain to a domain group to start managing this domain using global policies in Cisco UCS Central.

Cisco UCS Central creates a hierarchy of Cisco UCS domain groups for managing multiple Cisco UCS domains.

- **Domain Group**— A group that contains multiple Cisco UCS domains. You can group similar Cisco UCS domains under one domain group for simpler management.
- **Ungrouped Domains**—When a new Cisco UCS domain is registered in Cisco UCS Central, it is added to the ungrouped domains. You can assign the ungrouped domain to any domain group.

If you have created a domain group policy, and a new registered Cisco UCS domain meets the qualifiers defined in the policy, it is automatically placed under the domain group specified in the policy. If not, it is placed in the ungrouped domains category until the domain group is assigned to a domain group.

You can only assign each Cisco UCS domain to one domain group. You can assign or reassign membership of the Cisco UCS domains at any time. When you assign a Cisco UCS domain to a domain group, the Cisco UCS domain automatically inherits all management policies specified for the domain group.

Before adding a Cisco UCS domain to a domain group, make sure to change the policy resolution controls to local in the Cisco UCS domain. This avoids accidentally overwriting service profiles and maintenance policies specific to that Cisco UCS domain. Even when you have enabled auto discovery for the Cisco UCS domains, enabling local policy resolution protects the Cisco UCS domain from accidentally overwriting policies.

Creating or Editing a Domain Group

Procedure

- Step 1** In the **Actions** bar, type **Create Domain Group** and press Enter.
 - Step 2** In the **Domain Group** dialog box, click **Basic** and choose the **Domain Group Location** in which you want to create the domain group.
 - Step 3** Enter a **Name** and optional **Description**.
The name is case sensitive.
 - Step 4** In **Qualification**, select the **Qualification Policies** that you want to use to identify the Cisco UCS Manager domains.
All domains that meet the qualification policy are automatically added to the domain group.
 - Step 5** In **Domains**, select the Cisco UCS Manager domains that you want to add to the domain group.
 - Step 6** Click **Create**.
-

Adding a Domain to a Domain Group

Procedure

- Step 1** In the **Actions** bar, type **Assign Domain to Domain Group**.
 - Step 2** In the **Domain to Domain Group** dialog box, in the **Domain** drop-down, select the Cisco UCS Manager domain that you want to add to the domain group.
Note You can also select a domain, click the Operations icon, and select **Assign Domain to Domain Group**. In this case, the Cisco UCS Manager domain is pre-populated in the **Domain** drop-down.
 - Step 3** In the **Domain Group Location** drop-down, select domain group where you want to add the domain.
 - Step 4** Click **Assign**.
-

Managing Domain Group SNMP

Procedure

- Step 1** Click the **Domain Group Navigation** icon and choose a domain group.
- Step 2** Click the **Configuration** icon and choose **SNMP**.
- Step 3** In **Basic**, click **Enabled**, then enter the **Community/User Name**.
Cisco UCS includes the SNMP v1 or v2c community name or the SNMP v3 username when it sends the trap to the SNMP host. This must be the same as the community or username that is configured in **SNMP Traps**.
- Step 4** Enter the optional **System Contact** and **System Location**.
- Step 5** In **SNMP Traps**, click **Add** and complete the following:
- Enter the same **Community/User Name** from the **Basic** section.
 - Enter the **Port**, and select values for the **SNMP Version**, the **Type**, and the **V3 Privilege**.
- Step 6** In **SNMP Users**, click **Add** and complete the following:
- Enter the **SNMP User Name**.
 - Select the **Authentication Type** and whether to enable **AES-128 Encryption**.
 - Enter and confirm the values for the password and privacy password.
- Step 7** Click **Save**.
-

Domain Group Qualification Policy

Domain group qualification policy enables you to automatically place new Cisco UCS domains under domain groups. You can create qualifiers based on Owner, Site and IP Address of various Cisco UCS domains based on your management requirements. When you register a new Cisco UCS domain, Cisco UCS Central analyses the domain based on the pre defined qualifiers in the domain group qualification policy and places the domain under a specific domain group for management.

Creating or Editing a Domain Group Qualification Policy

Procedure

- Step 1** In the **Actions** bar, type **Create Domain Group Qualification Policy** and press Enter.
- Step 2** In the **Domain Group Qualification Policy** dialog box, click **Basic** and choose the **Organization** in which you want to create the domain group qualification policy.
- Step 3** Enter a **Name** and optional **Description**.
The policy name is case sensitive.

- Step 4** In **Owner**, enter the owner name and regex.
- Step 5** In **Site**, enter the site name and regex.
- Step 6** In **IP Address**, add the IP address ranges.
- Step 7** Click **Create**.
-

Organization

The **Organization** page enables you to view logical entities created under an organization that exists in a registered Cisco UCS domain.

Click one of the following icons to launch the specific page.

- **Service Profiles**—Displays all service profiles in the organization.
- **Service Profile Templates**—Displays all service profile templates in the organization.
- **Pools**—Displays all pools in the organization.
- **Policies**—Displays all policies in the organization.
- **Permitted VLANs**—Displays VLANs permitted in the organization.

Updating Organization Descriptions

After an organization is created, you can update the description.

Procedure

- Step 1** From the **Organization** page, click the **Edit** icon.
- Step 2** In the **Edit Organization** dialog box, enter the **Description** for the organization.
- Step 3** Click **Save**.
-



Tags

- [Tags and Tag Types, page 35](#)

Tags and Tag Types

Cisco UCS Central uses tags to allow users to group objects outside of the Organization or Domain Group structures. You can use the following types of tags:

- System-defined tags—Tags that are defined by Cisco UCS Central. This includes the Maintenance Group tag, the Operating System for HCR tag, and the Adapter Driver for HCR tag.
- User-defined tags—Tags that are created by users but have specific values.
- Basic tags—Free text tags that can allow any value.

From the **Tag Management** page in the GUI, you can view all Tag Types that have been created in Cisco UCS Central. However, you can view only the Tags that are associated with an object and are in active use at any given time.

Creating a Tag Type

Only users with the Tag permission can create tag types.

Procedure

- Step 1** In the **Actions** bar, type **Create Tag Type** and press Enter.
- Step 2** In the **Basic** tab, enter the **Name** and optional **Description**.
- Step 3** Select a color to assign to the tag, or accept the default.
- Step 4** Choose whether you want to allow this tag to be assigned more than once to the same object.
- Step 5** Choose one of the following:
 - **Free Text**—Allows any text to be entered when the tag is assigned.

- **Predefined List**—You can create a list of values, or add additional values to a list of values. When the tag is assigned, you choose one of the values from the list.

Click the **Values** tab to add the specific values.

Step 6 Click **Create**.

Adding a Tag

You can add tags to policies, logical resources such as service profiles and ID pools, and physical inventory components such as domains or servers.

Procedure

Step 1 Navigate to the item that you want to tag.

Step 2 Click the **Tag** icon.

Step 3 In the **Add Tag** drop-down, select the tag type that you want to use.

Note All user-defined tag types are displayed, but only system-defined tag types that can be applied to the specific object are listed. For example, you cannot apply a Maintenance Group tag type to a VLAN, so that tag type is hidden.

Step 4 Enter the values for the tag or select the tag value from the drop-down list.

Step 5 Click **Add**.



CHAPTER 6

License Management

- [Overview, page 37](#)

Overview

Cisco Smart licensing is simple, flexible and a smart way of procuring, deploying and managing licenses in your environment. For more information on smart licensing, see <http://www.cisco.com/web/ordering/smart-software-licensing/index.html>

You can have smart licensing and traditional licensing in your system at the same time. But only one type of licensing can be active. The following table describes the differences between traditional and smart licensing:

| Traditional Licensing | Smart Licensing |
|-----------------------------------------------------------------------------------------------------|----------------------------------------------------------------------------------------------------------------------------------------------------------------|
| Licenses are associated with registered domains. | Dynamic licensing. Licenses are associated with products and transferable within the virtual account. |
| You must obtain a license and manually download and install it on each device in Cisco UCS Central. | No license installation is necessary. The device initiates an HTTPS call home session and requests the licenses that it is configured to use. |
| Licenses are associated with specific domains. | License pools are account-specific. Any device in your company can use them. |
| Licenses are not easily transferable from one device to another. | Licenses can be transferred between product instances without any software installation. You can transfer unused licenses from one virtual account to another. |

Smart Licensing

Smart licenses are server based licenses. You will purchase, deploy and track licenses for servers instead of domains. Instead of registering individual products with license files or PAKs, Smart Licensing provides the option to create a pool of licenses that can be used across your company's portfolio.

Smart licensing uses Virtual Accounts, Product Instances and Registration Tokens to procure, deploy and manage licenses in your environment.

Virtual Accounts

Virtual accounts are collections of licenses and product instances. You can create virtual accounts in Cisco Smart Software Manager to organize the licenses for your company into logical entities. You can use virtual accounts to organize licenses by business unit, product type, IT group, or whatever makes sense for your organization. For example, if you segregate your company into different geographic regions, you can create a virtual account for each region to hold the licenses and product instances for that region.

All new licenses and product instances are placed in a virtual account. You choose the virtual account when you register a product instance. You can transfer existing licenses or product instances from one virtual account to another.

For more information on creating virtual accounts in Cisco Smart Software Manager, see <http://www.cisco.com/web/ordering/smart-software-manager/docs/smart-software-manager-user-guide.pdf>.

Product Instances

A Cisco UCS Central product instance has a unique device identifier (UDI) that is registered using a product instance registration token. You can register several instances of a product with a single registration token. Each product instance can have one or more licenses that reside in the same virtual account.

Registration Tokens

Registration tokens are stored in the Product Instance Registration Token Table that is associated with your smart account. After you enable Smart Licensing in Cisco UCS Central, you can generate a new token in a virtual account on the Smart Software Licensing portal to register in Cisco UCS Central.

For more information on creating virtual accounts in Cisco Smart Software Manager, see <http://www.cisco.com/web/ordering/smart-software-manager/docs/smart-software-manager-user-guide.pdf>.

Obtaining Licenses

To obtain licenses using smart licensing, you will have to do the following:

- Generate tokens in Cisco Smart Software Manager virtual accounts.
- Register licenses for product instances in Cisco UCS Central.

The following illustrations explain the smart licensing process:

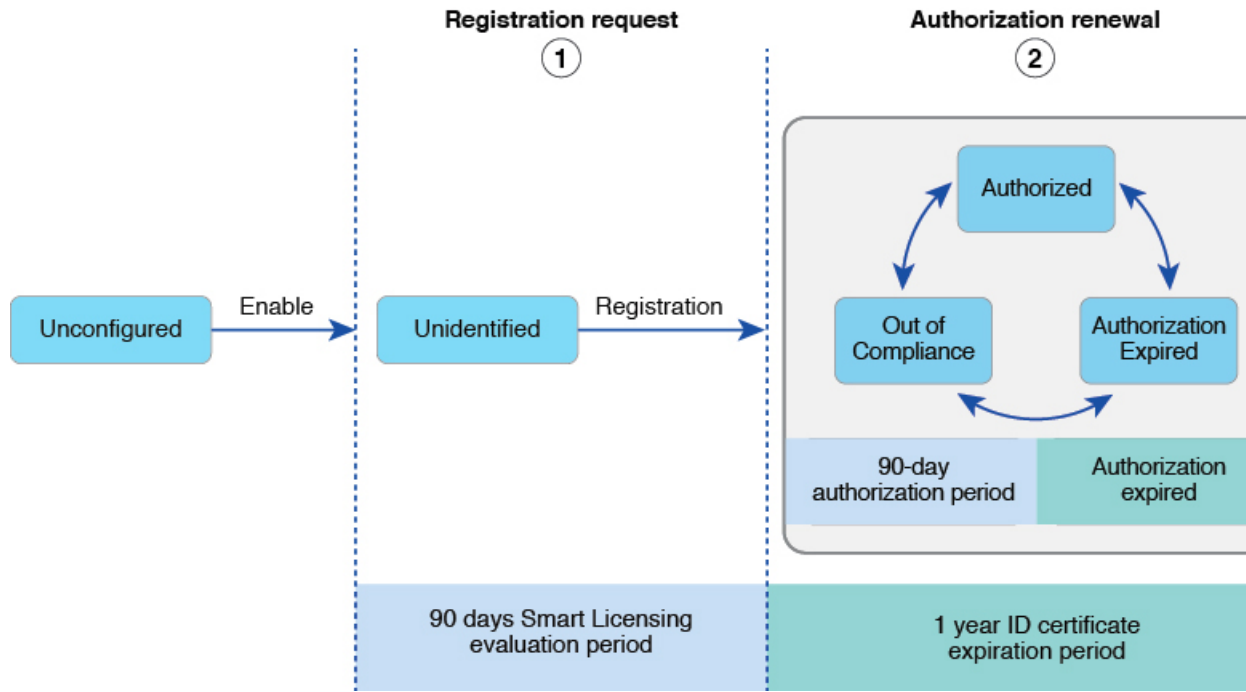

| | | |
|---|------------------------------|---------------------------------------------------------------------------------------------------------------------------------------------------------------------------------------------------------------------------------------------------------------------------------------------------------------------------------------------------------------------------------------------------------------------------------------------------------------------------------------------------------------------------------------------------------------------------------------------------------------------------|
| 1 | Registration request | The Smart Licensing 90-evaluation period starts when the product instance begins using the licensing feature. It not renewable. When the evaluation period expires, the agent sends a notification to the platform. |
| 2 | Authorization renewal | Authorization requests can result in an Authorized or Out of Compliance (OOC) response, or in an error due to a communication failure. Authorization periods are renewed every 30 days as long as authorization requests return Authorized or Out of Compliance (OOC) responses. When the authorization period expires, the agent continues to retry renewal with authorization requests. If successful, a new authorization period starts. If ID cert renewal (authorization renewal) fails, the product instance moves to an Unidentified state and begins consuming the evaluation period. |

Enabling Smart Licensing

Before You Begin

Make sure you have enabled Smart Call Home before enabling Smart Licensing. Enabling Smart Call Home includes the following:

- Specify a DNS server.
- Set up Smart Call Home.

- Make sure your Smart Call Home URL is correct. This is the URL the system uses to connect to the smart license server.



Note Although you must enable Smart Call Home, a Smart Call Home contract ID is not required to use Smart Licensing.

Procedure

-
- Step 1** Click the **System Configuration** icon and choose **Licenses**.
- Step 2** Click **Enable Smart Software Licensing**.
System enables smart licensing and information related to traditional licensing is replaced smart licensing related information.
-

Registering UCS Central Using a License Token

Before You Begin

Make sure Smart Licensing is enabled.

Procedure

-
- Step 1** Click the **System Configuration** icon and choose **Licenses**.
- Step 2** Click the **Smart Software Manager** link to go to the Smart Software Manager portal.
- Step 3** In the Smart Software Manager portal:
- Select a Cisco UCS Central virtual account.
 - Click **New Token** in the **Product Instance Registration Tokens** panel and select **Copy**.
- Step 4** In the Cisco UCS Central **Smart Software Licensing** panel, click **Register Smart Software Licensing**.
- Step 5** In the **Register Smart Licensing** dialog box, paste the new token you generated in the **Product Instance Registration Token** text box.
- Step 6** Click **Register**.
-

You will receive notifications on registration in progress, successful registration or failure to register. If there are problems with your Smart Call Home settings, a **Failed** message will appear with a link to the **Call Home Configuration**.

Renewing Authorization

License authorization is used to show if you have enough licenses for your system, or if you are out of compliance. Authorization is renewed automatically by the Smart Licensing agent every 30 days, provided the network is up and Cisco UCS Central can reach the Smart License server.

If authorization is not renewed for 90 days, the authorization will expire.

Procedure

- Step 1** Click the **System Configuration** icon and choose **Licenses**.
 - Step 2** In the Cisco UCS Central **Smart Software Licensing** panel, click the **Tools** menu.
 - Step 3** Select **Renew Authorization Now**.
-

Renewing Registration

The agent automatically renews the Smart Software Licensing registration certificate or the ID certificate every six months. Certification lasts for one year. If Cisco UCS Central cannot communicate with the Smart License Server, it may fail to renew the certificate. If this occurs, the certification will revert to evaluation state after one year.

Procedure

- Step 1** Click the **System Configuration** icon and choose **Licenses**.
 - Step 2** In the Cisco UCS Central **Smart Software Licensing** panel, click the **Tools** menu.
 - Step 3** Select **Renew Registration Now**.
-

Deregistering Smart Software Licensing

When you deregister a product instance from Smart Software Licensing, the product will not be associated with the license. The product will be removed from the list of registered products for the associated virtual account. You can use the license to register another product, or reregister a product that has been deregistered.

Procedure

- Step 1** Click the **System Configuration** icon and choose **Licenses**.
 - Step 2** In the Cisco UCS Central **Smart Software Licensing** panel, click the **Tools** menu.
 - Step 3** Select **Deregister** to remove Cisco UCS Central from Smart Software Manager.
-

Disabling Smart Software Licensing

If you disable Smart Software Licensing, Cisco UCS Central automatically returns to the Traditional Licensing mode.



Note Only one licensing mode is supported at a time.

Procedure

- Step 1** Click the **System Configuration** icon and choose **Licenses**.
 - Step 2** In the Cisco UCS Central **Smart Software Licensing** panel, click the **Action** menu.
 - Step 3** Select **Disable Smart Software Licensing**.
-

Traditional Licensing

Traditional PAK-based licensing uses domain-based licenses instead of the product-based license that Smart Licensing offers. You can manage domain licenses through the Cisco UCS Central GUI or CLI.

You have a 120 day grace period to evaluate Cisco UCS Central at no cost. The grace period is measured from the day you register your first Cisco UCS domain and is stored in the system. Unregistering a domain from the system does not reset the grace period. For example, if you register a domain, use 40 days of the grace period, and then unregister after 40 days, the system records the 40 days in association with that domain. If you register this Cisco UCS domain again, the grace period for the domain resumes and indicates that you have used 40 days.

You must obtain and install a valid domain license before the grace period expires. If you do not the system generates multiple faults as a reminder to procure a license.

Obtaining a Traditional License

Before You Begin

Obtain the Product Authorization Key (PAK) from the claim certification or other proof of purchase documentation.

Procedure

- Step 1** On the menu bar, click **System Configuration** icon and select **Licenses**. This launches a **License** information page.
- Step 2** Click **UCS Central GUID** link and copy the GUID to your clipboard. The GUID is unique to each Cisco UCS Central instance for obtaining licenses.
- Step 3** Click **Cisco SWIFT** to open the Product License Registration portal. Videos on this page provide information on software licensing features and operations.

- Step 4** Login and click **Continue to Product License Registration**.
- Step 5** On the **Product License Registration** page, enter the PAK in the **Get New Licenses** field and click **Fulfill**.
- Step 6** On the **Assign SKUs to Devices** page, check the **Quantity Available** checkbox next to the PAK that you entered.
- Step 7** Enter the GUID in the **GUID** field, and click **Assign**.
- Step 8** Click **Next**.
- Step 9** On the **Review** page, enter your email address, select the user ID, and check the **License Agreement** checkbox.
- Step 10** Click **Get License**.

Cisco sends you the license zip file by email. The license file is digitally signed to authorize use on only the specified Cisco UCS domain.

Caution After you obtain the license file, you must not tamper with the license code. Any manual edits from your part breaks the tamper proof, and disables the license.

What to Do Next

Unzip the license file and install it.

Downloading a License from a Local File System

Before You Begin

To download a license from the local file system to Cisco UCS Central, make sure you have the following:

- A Cisco product license saved it to your local system.
- Administrative permission for Cisco UCS Central to perform this task.

Procedure

- Step 1** Click the **System Configuration** icon and choose **Licenses**.
This launches the **License** information page.
- Step 2** Click **Install License**.
- Step 3** Click **Local**
- Step 4** In the **Filename** dialog box, type the full path and the name of the license.
If you do not know the exact path to the folder where the license is located, click **Choose File** to navigate and select the file.
- Step 5** Click **Install**.
Cisco UCS Central downloads the license.
-

Downloading a License from a Remote File System

Before You Begin

To download a license from a remote location to Cisco UCS Central, make sure you have the following:

- A Cisco product license saved to a remote location.
- The username and password required to access an FTP, SCP, or SFTP server if necessary.
- Administrative permission for Cisco UCS Central to perform this task.

Procedure

- Step 1** Click the **System Configuration** icon and select **Licenses**.
This launches a **License** information page.
- Step 2** Click **Install License**.
- Step 3** In the **Download License** dialog box, click **Remote**.
- Step 4** Select the protocol to use to communicate with the remote server.
- **FTP**
 - **TFTP**
 - **SCP**
 - **SFTP**
- Step 5** In the **Path** field, enter the absolute path to the license file on the remote server, if required.
If you use SCP, the absolute path is always required. If you use any other protocol, you may not need to specify a remote path if the file resides in the default download folder. For details about how your file server is configured, contact your system administrator.
- Step 6** In the **User Name** field, enter the user name to log into the remote server.
If you selected TFTP, this field does not apply.
- Step 7** In the **Password** field, enter the password for the remote server user name.
If you selected TFTP, this field does not apply.
- Step 8** Click **Install**.
Cisco UCS Central downloads the license.
-

Installing a License

Make sure the license is downloaded in Cisco UCS Central.

Procedure

- Step 1** On the menu bar, click **System Configuration** icon and choose **Licenses**.
 - Step 2** Click the **Install** icon.
Launches the License Install dialog box.
 - Step 3** In the License Install dialog box, select **Local** or **Remote** file location, enter required information and select the license file.
 - Step 4** Click **Install**.
The **Overall License Status** column displays the status of the installation. When you initiate the installation, the status in this column displays **Install-pending**. After the license is installed, the status changes to **Installed**.
-

Deleting a Traditional License

You can delete a traditional license that is not associated with a registered UCS domain, from Cisco UCS Central. If you want to delete a license that is associated to a UCS domain, make sure to unregister the domain before deleting the license. When you delete a license, the system automatically adjusts the available license count.



- Important** Deleting a license from Cisco UCS Central removes only the license file from the system. If you try to download the same license after deleting it from the system, you might encounter a download license error. So when you delete a license, you must delete the associated download task for that license.
-

Procedure

- Step 1** Click the **System Configuration** icon and choose **Licenses**.
This launches a **License** information page.
 - Step 2** Select the license you want to uninstall.
 - Step 3** Click **Delete**.
 - Step 4** Click **Yes** in the confirmation dialog box.
The license file is deleted from Cisco UCS Central.
-

