



Overview

This chapter contains the following topics:

- [Overview, on page 1](#)
- [External Features, on page 5](#)
- [Summary of Server Features, on page 30](#)
- [Serviceable Component Locations, on page 38](#)

Overview

The Cisco UCS C240 M6 is a stand-alone 2U rack server chassis that can operate in both standalone environments and as part of the Cisco Unified Computing System (Cisco UCS).

The Cisco UCS C240 M6 servers support a maximum of two 3rd Gen Intel® Xeon® Scalable Processors, in either one or two CPU configurations.

The servers support:

- 16 DIMM slots per CPU for 3200-MHz DDR4 DIMMs in capacities up to 128 GB DIMMs.
- A maximum of 8 or 12 TB of memory is supported for a dual CPU configuration populated with either:
 - DIMM memory configurations of either 32 128 GB DDR DIMMs, or 16 128 GB DDR4 DIMMs plus 16 512 GB Intel® Optane™ Persistent Memory Modules (DCPMMs).
- The servers have different supported drive configurations depending on whether they are configured with large form factor (LFF) or small form factor (SFF) front-loading drives.
- The C240 M6 12 LFF supports midplane mounted storage through a maximum of r4 LFF HDDs.
- Up to 2 M.2 SATA RAID cards for server boot.
- Rear Storage risers (2 slots each)
- One rear PCIe riser (3 slots)
- Internal slot for a 12 G SAS RAID controller with SuperCap for write-cache backup, or for a SAS HBA.
- Network connectivity through either a dedicated modular LAN over motherboard card (mLOM) that accepts a series 14xx/15xxx Cisco virtual interface card (VIC) or a third-party NIC. These options are in addition to Intel x550 10Gbase-T mLOM ports built into the server motherboard.

- One mLOM/VIC card provides 10/25/40/50/100 Gbps. The following mLOMs are supported:
 - Cisco UCS VIC 15238 Dual Port 40/100G QSFP28 mLOM (UCSC-M-V5D200G) supports:
 - a x16 PCIe Gen4 Host Interface to the rack server
 - two 40G/100G QSFP28 ports
 - 4GB DDR4 Memory, 3200 MHz
 - Integrated blower for optimal ventilation
 - Cisco UCS VIC 15428 Quad Port CNA MLOM (UCSC-M-V5Q50G) supports:
 - a x16 PCIe Gen4 Host Interface to the rack server
 - four 10G/25G/50G SFP56 ports
 - 4GB DDR4 Memory, 3200 MHz
 - Integrated blower for optimal ventilation
 - Cisco UCS VIC 1467 Quad Port 10/25G SFP28 mLOM (UCSC-M-V25-04) supports:
 - a x16 PCIe Gen3 Host Interface to the rack server
 - four 10G/25G QSFP28 ports
 - 2GB DDR3 Memory, 1866 MHz
 - Cisco UCS VIC 1477 Dual Port 40/100G QSFP28 (UCSC-M-V100-04)
 - a x16 PCIe Gen3 Host Interface to the rack server
 - two 40G/100G QSFP28 ports
 - 2GB DDR3 Memory, 1866 MHz

These options are in addition to Intel x550 10Gbase-T mLOM ports built into the server motherboard.

- The following virtual interface cards (VICs) are supported in addition to some third-party VICs):
 - Cisco UCS VIC 15427 Quad Port CNA MLOM (UCSC-M-V5Q50GV2) supports:
 - a x16 PCIe Gen4 Host Interface to the rack server
 - four 10G/25G/50G SFP+/SFP28/SFP56 ports
 - 4GB DDR4 Memory, 3200 MHz
 - Integrated blower for optimal ventilation
 - Secure boot support
 - Cisco UCS VIC 15425 Quad Port 10G/25G/50G SFP56 CNA PCIe (UCSC-P-V5Q50G)
 - a x16 PCIe Gen4 Host Interface to the rack server
 - Four 10G/25G/50G SFP+/SFP28/SFP56 ports

- 4GB DDR4 Memory, 3200MHz
- Integrated blower for optimal ventilation
- Secure boot support
- Cisco UCS VIC 15237 Dual Port 40G/100G/200G QSFP56 mLOM (UCSC-M-V5D200GV2) supports:
 - a x16 PCIe Gen4 Host Interface to the rack server
 - two 40G/100G/200G QSFP/QSFP28/QSFP56 ports
 - 4GB DDR4 Memory, 3200 MHz
 - Integrated blower for optimal ventilation
 - Secure boot support
- Cisco UCS VIC 15235 Dual Port 40G/100G/200G QSFP56 CNA PCIe (UCSC-P-V5D200G)
 - a x16 PCIe Gen4 Host Interface to the rack server
 - two 40G/100G/200G QSFP/QSFP28/QSFP56 ports
 - 4GB DDR4 Memory, 3200MHz
 - Integrated blower for optimal ventilation
 - Secure boot support
- Cisco UCS VIC 1455 quad port 10/25G SFP28 PCIe (UCSC-PCIE-C25Q-04=)
- Cisco UCS VIC 1495 Dual Port 40/100G QSFP28 CNA PCIe (UCSC-PCIE-C100-042)
- Two power supplies (PSUs) that support N+1 power configuration.
- Six modular, hot swappable fans.

Server Configurations, LFF

The server is orderable with the following configuration for LFF drives.

- Cisco UCS C240 M6 LFF 12 (UCSC-C240-M6L)—Large form-factor (LFF) drives, with a 12-drive backplane.
 - Front-loading drive bays 1—12 support 3.5-inch SAS/SATA drives.
 - The midplane drive cage supports four 3.5-inch SAS-only drives.
 - Optionally, rear-loading drive bays support either two or four SAS/SATA or NVMe drives.

Server Configurations, SFF 12 SAS/SATA

The SFF 12 SAS/SATA configuration (UCSC-C240-M6-S) can be configured with 12 SFF drives and an optional optical drive. Also, The SFF configurations can be ordered as either an I/O-centric configuration or a storage centric configuration. This server supports the following:

- A maximum of 12 Small form-factor (SFF) drives, with a 12-drive backplane.
 - Front-loading drive bays 1—12 support a maximum of 12 2.5-inch SAS/SATA drives as SSDs or HDDs.
 - Optionally, drive bays 1—4 can support 2.5-inch NVMe SSDs. In this configuration, any number of NVMe drives can be installed up to the maximum of 4.



Note NVMe drives are supported only on a dual CPU server.

- The server can be configured with a SATA Interposer card. If your server uses a SATA Interposer card, up to a maximum of 8 SATA-only drives can be configured. These drives can be installed only in slots 1-8.
- Drive bays 5 —12 support SAS/SATA SSDs or HDDs only; no NVMe.
- Optionally, the rear-loading drive bays support four 4 2.5-inch SAS/SATA or NVMe drives.

Server Configurations, 24 SFF SAS/SATA

The SFF 24 SAS/SATA configuration (UCSC-C240-M6SX) can be ordered as either an I/O-centric configuration or a storage centric configuration. This server supports the following:

- A maximum of 24 small form-factor (SFF) drives, with a 24-drive backplane.
 - Front-loading drive bays 1—24 support 2.5-inch SAS/SATA drives as SSDs or HDDs.
 - Optionally, drive bays 1—4 can support 2.5-inch NVMe SSDs. In this configuration, any number of NVMe drives can be installed up to the maximum of 4.



Note NVMe drives are supported only on a dual CPU server.

- Drive bays 5 —24 support SAS/SATA SSDs or HDDs only; no NVMe.
- Optionally, the rear-loading drive bays support four 4 2.5-inch SAS/SATA or NVMe drives.
- As an option, this server can be ordered with "GPU ready" configuration. This option supports adding GPUs at a later date even though the GPU is not purchased at the time the server is initially ordered.



Note To order the GPU Ready configuration through the Cisco online ordering and configuration tool, you must select the GPU air duct PID to enable GPU ready configuration. Follow the additional rules displayed in the tool. For additional information, see [GPU Card Configuration Rules](#).

Server Configurations, 12 NVMe

The SFF 12 NVMe configuration (UCSC-C240-M6N) can be ordered as an NVMe-only server. The NVMe-optimized server requires two CPUs. This server supports the following:

- A maximum of 12 SFF NVMe drives as SSDs with a 12-drive backplane, NVMe-optimized.
 - Front-loading drive bays 1—12 support 2.5-inch NVMe PCIe SSDs *only*.
 - The two rear-loading drive bays support two 2.5-inch NVMe SSDs *only*. These drive bays are the top and middle slot on the left of the rear panel.

Server Configurations, 24 NVMe

The SFF 24 NVMe configuration (UCSC-C240-M6SN) can be ordered as an NVMe-only server. The NVMe-optimized server requires two CPUs. This server supports the following:

- A maximum of 24 SFF NVMe drives as SSDs with a 24-drive backplane, NVMe-optimized.
 - Front-loading drive bays 1—24 support 2.5-inch NVMe PCIe SSDs *only*.
 - The two rear-loading drive bays support two 2.5-inch NVMe SSDs *only*. These drive bays are the top and middle slot on the left of the rear panel.
 - As an option, this server can be ordered with "GPU ready" configuration. This option supports adding GPUs at a later date even though the GPU is not purchased at the time the server is initially ordered.



Note To order the GPU Ready configuration through the Cisco online ordering and configuration tool, you must select the GPU air duct PID to enable GPU ready configuration. Follow the additional rules displayed in the tool. For additional information, see [GPU Card Configuration Rules](#).

External Features

This topic shows the external features of the different configurations of the server.

For definitions of LED states, see [Front-Panel LEDs](#).

Cisco UCS C240 M6 Server 24 SAS/SATA Front Panel Features

The following figure shows the front panel features of Cisco UCS C240 M6SX, which is the small form-factor (SFF), 24 SAS/SATA drive version of the server. Front-loading drives can be mix and match in slots 1 through 4 to support up to four SFF NVMe or SFF SAS/SATA drives. UCS C240 M6 servers with any number of NVMe drives must be dual CPU systems.

This configuration can support up to 4 optional SAS/SATA drives in the rear PCIe slots.

Figure 1: Cisco UCS C240 M6 Server 24 SAS/SATA Front Panel

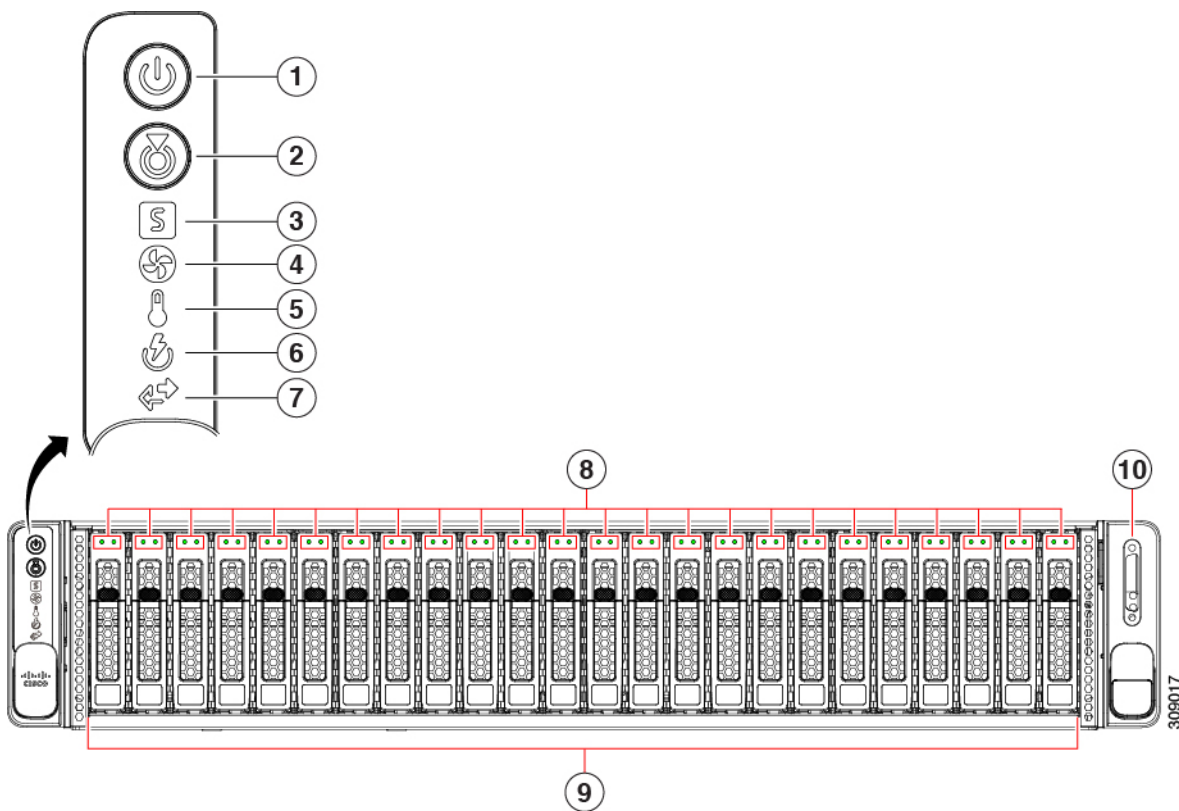

1	Power Button/Power Status LED	2	Unit Identification LED
3	System Status LEDs	4	Fan Status LED
5	Temperature Status LED	6	Power Supply Status LED
7	Network Link Activity LED	8	Drive Status LEDs
9	<p>NVMe Drive Bays, front loading</p> <p>Drive bays 1—24 support front-loading SFF SAS/SATA drives.</p> <p>Drive bays 1 through 4 can support SAS/SATA hard drives and solid-state drives (SSDs) or NVMe PCIe drives. Any number of NVMe drives up to 4 can reside in these slots.</p> <p>Drive bays 5 - 24 support SAS/SATA hard drives and solid-state drives (SSDs) only.</p> <p>Drive bays are numbered 1 through 24 with bay 1 as the leftmost bay.</p>	10	<p>KVM connector (used with KVM cable that provides one DB-15 VGA, one DB-9 serial, and two USB 2.0 connectors)</p>

Cisco UCS C240 M6 Server 12 SAS/SATA Drives Front Panel Features

The following figure shows the front panel features of Cisco UCS C240 M6S, which is the small form-factor (SFF) drive, 12 SAS/SATA drive version of the server. Front-loading drives can be mix and match in slots 1 through 4 to support up to four SFF NVMe or SFF SAS/SATA drives. UCS C240 M6 servers with any number of NVMe drives must be dual CPU systems.

This configuration can support up to 4 optional SAS/SATA or NVMe drives in the rear PCIe slots.

For definitions of LED states, see [Front-Panel LEDs](#).

Figure 2: Cisco UCS C240 M6 Server (SFF SAS/SATA, 12-Drive) Front Panel

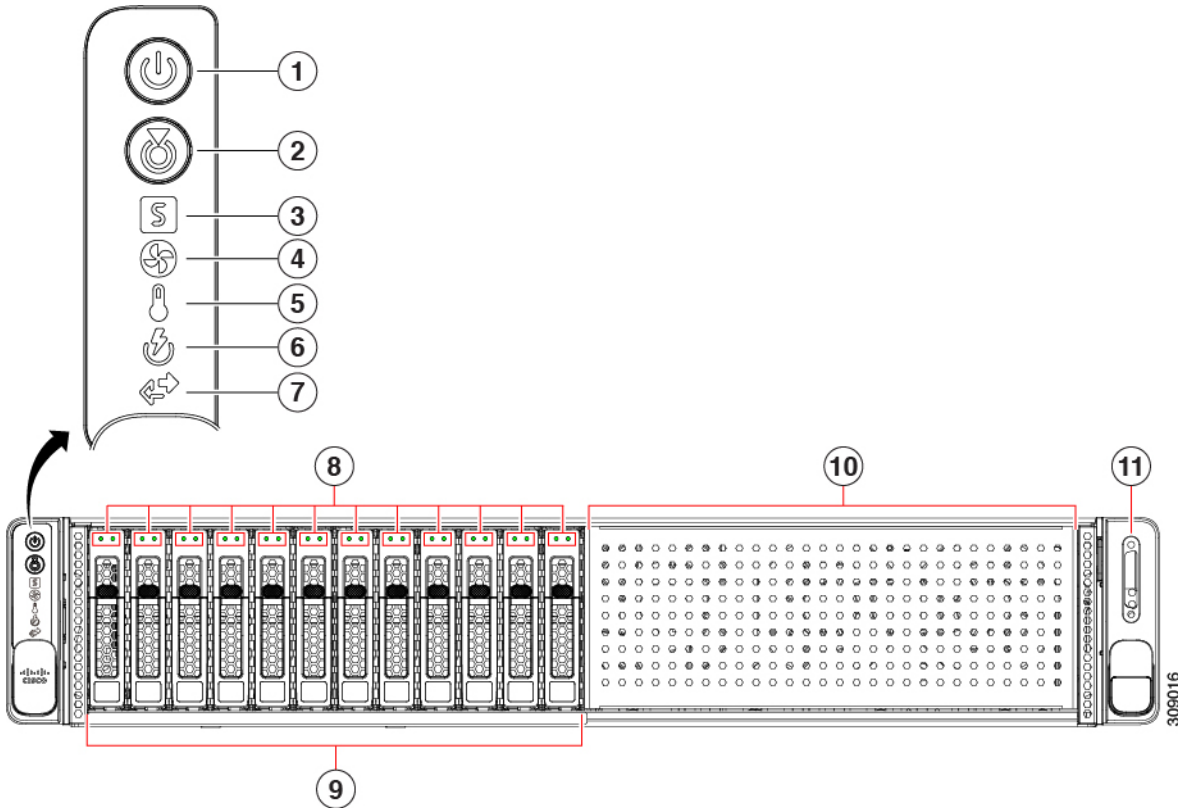

1	Power Button/Power Status LED	2	Unit Identification LED
3	System Status LEDs	4	Fan Status LED
5	Temperature Status LED	6	Power Supply Status LED
7	Network Link Activity LED	8	Drive Status LEDs

<p>9</p>	<p>Drive Bays front loading</p> <p>Drive bays 1—12 support front-loading SFF SAS/SATA drives.</p> <p>Drive bays 1 through 4 can support SAS/SATA hard drives and solid-state drives (SSDs) as well as NVME PCIe drives. Any number of NVMe drives up to 4 can reside in these slots.</p> <p>Drive bays 5 - 12 support SAS/SATA hard drives and solid-state drives (SSDs) only.</p> <p>Drive bays are numbered 1 through 24 with bay 1 as the leftmost bay.</p> <p>Note If the server has a SATA Interposer card, a maximum of 8 SATA drives is supported in slots 1 through 8.</p>	<p>10</p>	<p>Drive Bays 13 through 24 are blocked off with sheet metal.</p>
<p>11</p>	<p>KVM connector (used with KVM cable that provides one DB-15 VGA, one DB-9 serial, and two USB 2.0 connectors)</p>	<p>-</p>	

Cisco UCS C240 M6 Server 12 SAS/SATA Drives (Plus Optical) Front Panel Features

The following figure shows the front panel features of Cisco UCS C240 M6S, which is the small form-factor (SFF) drive, 12-drive version of the server. Front-loading drives can be mix and match in slots 1 through 4 to support up to four SFF NVMe or SFF SAS/SATA drives. UCS C240 M6 servers with any number of NVMe drives must be dual CPU systems.

This configuration can support up to 4 optional SAS/SATA drives in the rear PCIe slots.

For definitions of LED states, see [Front-Panel LEDs](#).

Figure 3: Cisco UCS C240 M6 Server 12 SAS/SATA Plus Optical Drive, Front Panel Features

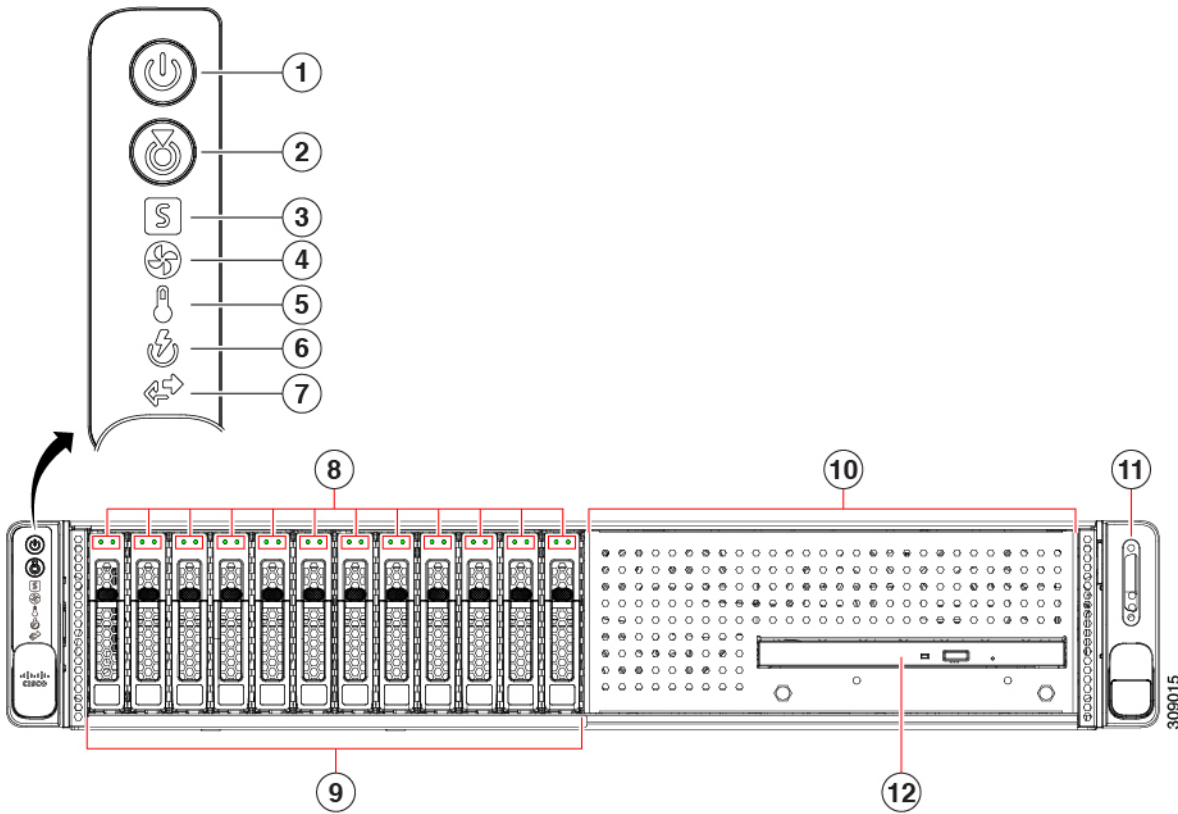

1	Power Button/Power Status LED	2	Unit Identification LED
3	System Status LEDs	4	Fan Status LED
5	Temperature Status LED	6	Power Supply Status LED
7	Network Link Activity LED	8	Drive Status LEDs
9	<p>Drive Status LEDs</p> <p>Drive bays 1—12 support front-loading SFF drives.</p> <p>Drive bays 1 through 4 can support SAS/SATA hard drives and solid-state drives (SSDs) as well as NVMe PCIe drives. Any number of NVMe drives up to 4 can reside in these slots.</p> <p>Note If the server has a SATA Interposer card, a maximum of 8 SATA drives is supported in slots 1 through 8.</p>	10	Drive bays 13-24 are blocked off with sheet metal.
11	KVM connector (used with KVM cable that provides one DB-15 VGA, one DB-9 serial, and two USB 2.0 connectors)	12	Optional optical DVD drive is installed horizontally.

Cisco UCS C240 M6 Server 12 NVMe Drive Front Panel Features

The following figure shows the front panel features of Cisco UCS C240 M6N, which is the small form-factor (SFF) drive, 12 NVMe drive version of the server. Front-loading drives are all NVMe only. UCS C240 M6 servers with any number of NVMe drives must be dual CPU systems.

This configuration can support up to 2 optional NVMe drives in the rear PCIe slots.

For definitions of LED states, see [Front-Panel LEDs](#).

Figure 4: Cisco UCS C240 M6 Server 12 NVMe Front Panel

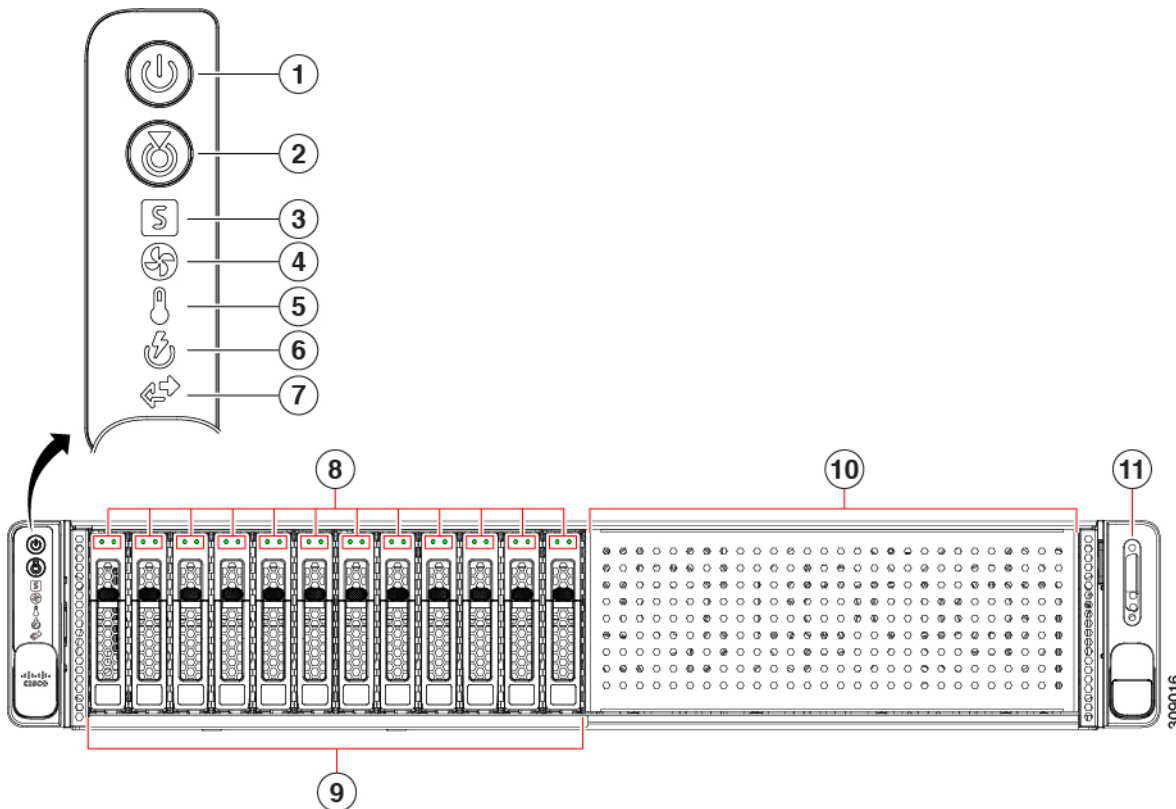

1	Power Button/Power Status LED	2	Unit Identification LED
3	System Status LEDs	4	Fan Status LED
5	Temperature Status LED	6	Power Supply Status LED
7	Network Link Activity LED	8	Drive Status LEDs
9	Drive bays 1—12 support front-loading SFF NVMe drives only. Drive bays are numbered 1 through 12 with bay 1 as the leftmost bay.	10	Drive bays 13 —24 are blocked off with sheet metal.
11	KVM connector (used with KVM cable that provides one DB-15 VGA, one DB-9 serial, and two USB 2.0 connectors)	-	

Cisco UCS C240 M6 Server 24 NVMe Drives Front Panel Features

The following figure shows the front panel features of Cisco UCS C240 M6SN, which is the small form-factor (SFF) drive, 24 NVMe drive version of the server. Front-loading drives are all NVMe; SAS/SATA drives are not supported. UCS C240 M6 servers with any number of NVMe drives must be dual CPU systems.

This configuration can support up to 2 optional NVMe drives in the rear PCIe slots.

Figure 5: Cisco UCS C240 M6 Server 24 NVMe Front Panel

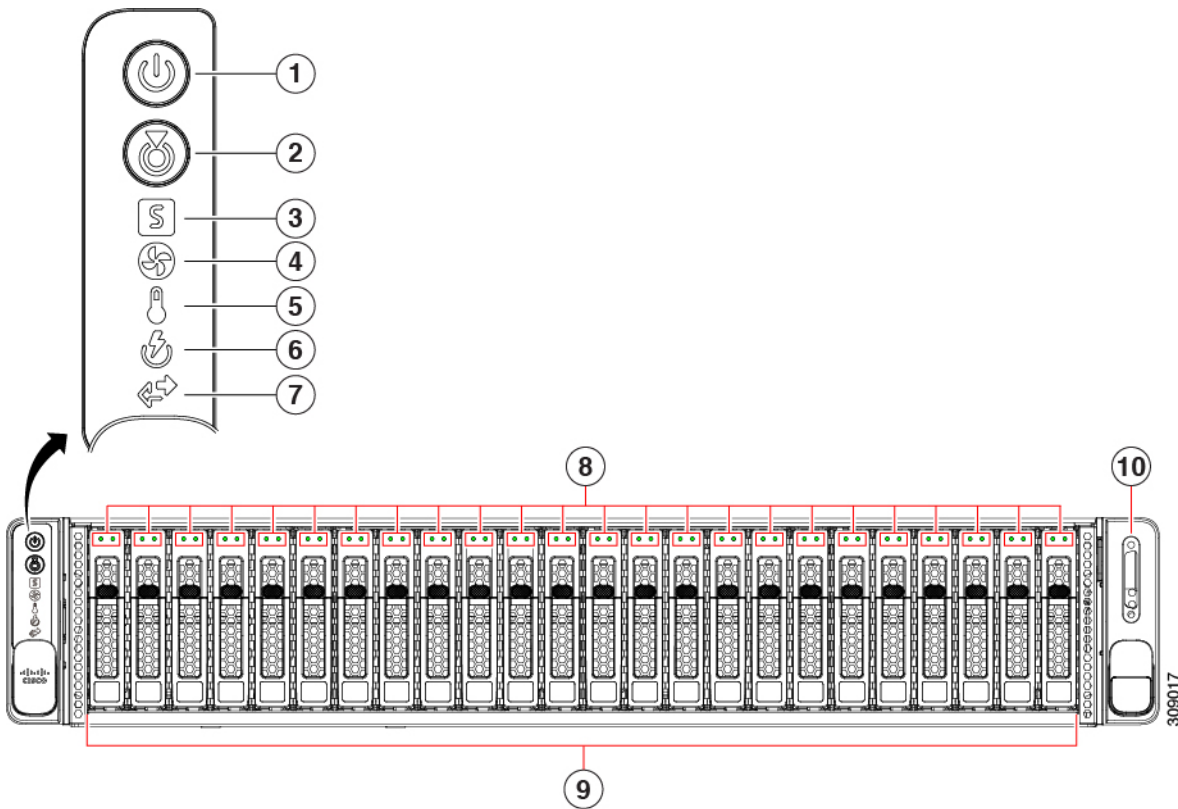

1	Power Button/Power Status LED	2	Unit Identification LED
3	System Status LEDs	4	Fan Status LED
5	Temperature Status LED	6	Power Supply Status LED
7	Network Link Activity LED	8	Drive Status LEDs
9	Drive Status LEDs	10	Drive bays 1—24 support front-loading SFF NVMe drives. Drive bays are numbered 1 through 24 with bay 1 as the leftmost bay.
11	KVM connector (used with KVM cable that provides one DB-15 VGA, one DB-9 serial, and two USB 2.0 connectors)	-	

Cisco UCS C240 M6 Server 12 LFF Drive Front Panel Features

The following figure shows the front panel features of the large form-factor (LFF) configuration of the server. This version of the server supports 12 3.5-inch LFF SAS-only front-loading hard disk drives (HDDs) plus up to 4 3.5-inch LFF mid-plane mounted HDDs. As an option, the server can also support up to 4 SFF drives as SAS, SATA, or NVME in the rear PCIe slots.

For definitions of LED states, see [Front-Panel LEDs](#).

Figure 6: Cisco UCS C240 M6 Server 12 LFF Drive Front Panel

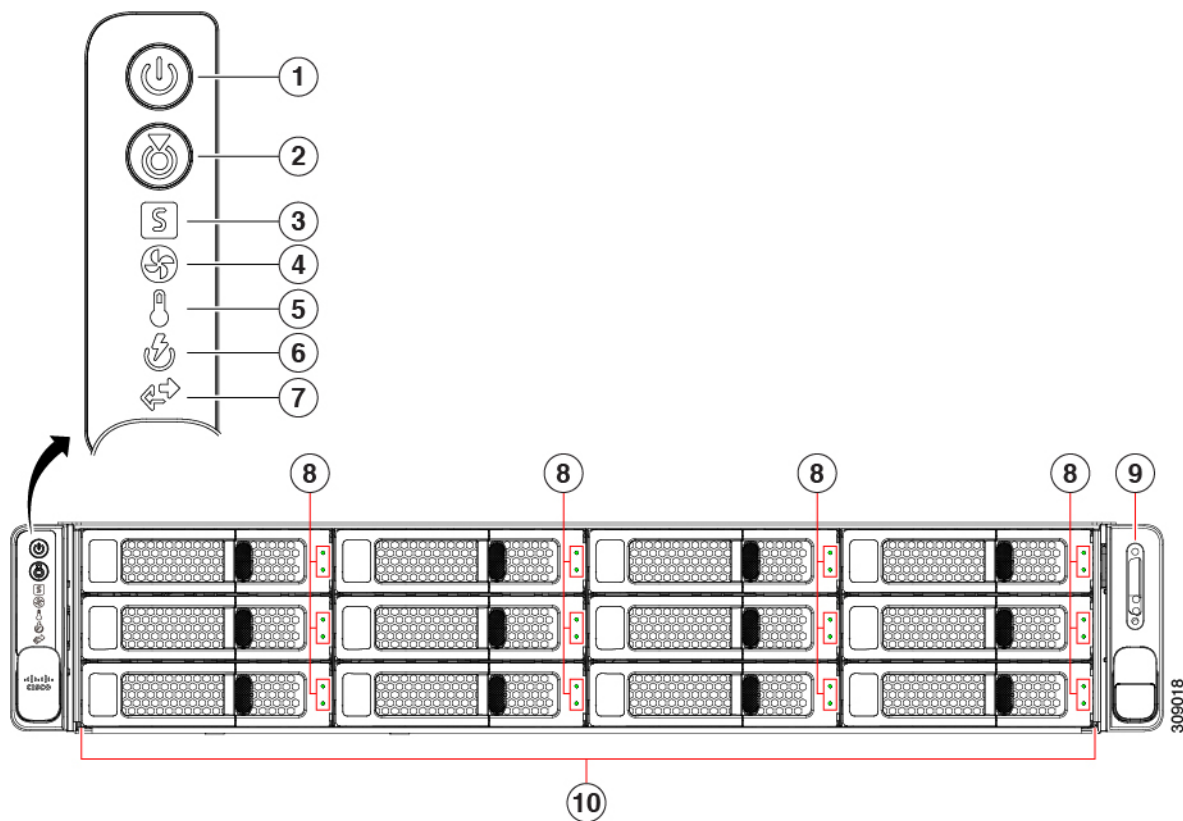

1	Power Button/Power Status LED	2	Unit Identification LED
3	System Status LEDs	4	Fan Status LED
5	Temperature Status LED	6	Power Supply Status LED
7	Network Link Activity LED	8	Drive Status LEDs
9	KVM connector (used with KVM cable that provides one DB-15 VGA, one DB-9 serial, and two USB 2.0 connectors)	10	Drive bays 1—12 support front-loading LFF SAS-only drives. Drive bays are numbered 1 through 12 with bay 1 as the leftmost bay, 12 as the rightmost bottom bay.

Common Rear Panel Features

The following illustration shows the rear panel hardware features that are common across all models of the server.

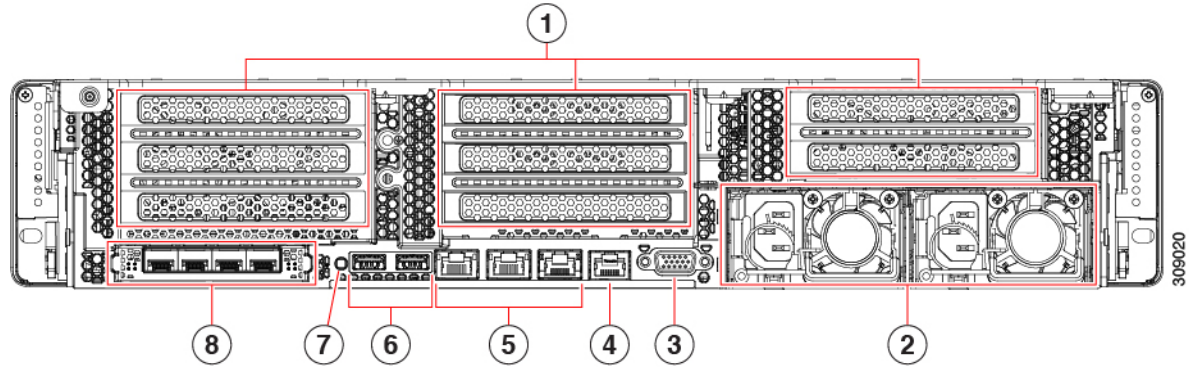

<p>1</p>	<p>Rear hardware configuration options:</p> <ul style="list-style-type: none"> • For I/O-Centric, these are PCIe slots. • For Storage-Centric, these are storage drives bays. <p>This illustration shows the slots unpopulated</p>	<p>2</p> <p>Power supplies (two, redundant as 1+1)</p> <p>See Power Specifications for specifications and supported options.</p>
<p>3</p>	<p>VGA video port (DB-15 connector)</p>	<p>4</p> <p>Serial port (RJ-45 connector)</p>
<p>5</p>	<p>1-Gb/10-Gb auto negotiating Ethernet ports, 2 which are ports 1 and 2 in the cluster.</p> <p>These LAN ports (LAN1 and LAN2) support 1 Gbps and 10 Gbps and auto negotiate to the optimal speed based on the link partner capability.</p> <p>The third port in the cluster is the dedicated 1 Gb management port.</p>	<p>6</p> <p>USB 3.0 ports, 2</p>
<p>7</p>	<p>Rear unit identification button/LED</p>	<p>8</p> <p>Modular LAN-on-motherboard (mLOM) card slot (x16)</p>

Cisco UCS C240 M6 Server 24 Drive Rear Panel, I/O Centric

The Cisco UCS C240 M6 24 SAS/SATA SFF version has a rear configuration option, for either I/O (I/O Centric) or Storage (Storage Centric) with the I/O Centric version of the server offering PCIe slots and the Storage Centric version of the server offering drive bays.

The following illustration shows the rear panel features for the I/O Centric version of the Cisco UCS C240 M6SX.

- For features common to all versions of the server, see Common Rear Panel Features.
- For definitions of LED states, see [Rear-Panel LEDs](#).

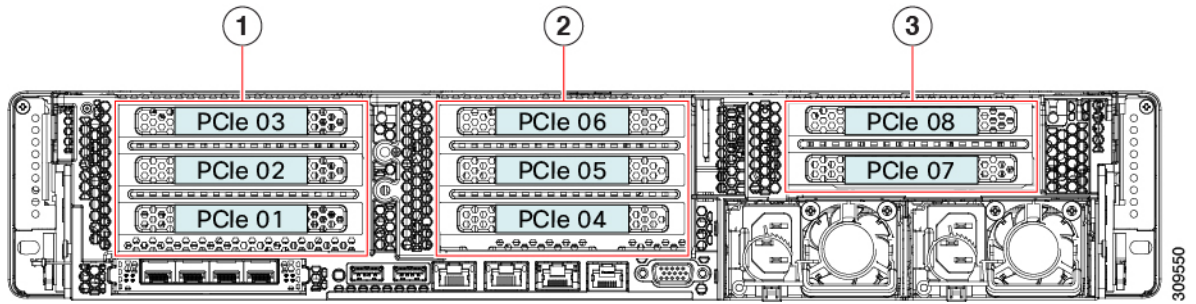

1	Riser 1A	2	Riser 2A
3	Riser 3A or 3C	-	-

The following table shows the riser options for this version of the server.

Table 1: Cisco UCS C240 M6 24 SFF SAS/SATA/NVMe (UCSC-C240-M6SX)

Riser	Options
<p>Riser 1</p> <p>This riser is I/O-centric and controlled by CPU 1 or CPU 2.</p>	<p>Riser 1A supports three PCIe slots numbered bottom to top:</p> <ul style="list-style-type: none"> • Slot 1 is full-height, 3/4 length, x8, NCSI • Slot 2 is full-height, full-length, x16, NCSI • Slot 3 is full-height, full-length, x8, no NCSI
<p>Riser 2</p> <p>This riser is I/O-centric and controlled by CPU 2.</p>	<p>Riser 2A supports three PCIe slots:</p> <ul style="list-style-type: none"> • Slot 1 is full-height, 3/4 length, x8, NCSI • Slot 2 is full-height, full-length, x16, NCSI • Slot 3 is full-height, full-length, x8, no NCSI
<p>Riser 3</p> <p>This riser is I/O-centric and controlled by CPU 2.</p>	<p>Riser 3A supports two PCIe slots:</p> <ul style="list-style-type: none"> • Slot 7 is full-height, full-length, x8 • Slot 8 is full-height, full-length, x8 <p>Riser 3C supports a GPU only.</p> <ul style="list-style-type: none"> • Supports one full-height, full-length, double-wide GPU (PCIe slot 7 only), x16 • Slot 8 is blocked by double-wide GPU

Cisco UCS C240 M6 Server 12 SAS/SATA Drive Rear Panel, I/O Centric

The Cisco UCS C240 M6 12 SAS/SATA SFF version has a rear configuration option, for either I/O (I/O Centric) or Storage (Storage Centric) with the I/O Centric version of the server offering PCIe slots and the Storage Centric version of the server offering drive bays.



Note This version of server has an option for a DVD drive on the front of the server. The rear panel shown here is the same for both the standard server and the DVD drive version of the server.

The following illustration shows the rear panel features for the I/O Centric version of the Cisco UCS C240 M6S.

- For features common to all versions of the server, see Common Rear Panel Features.
- For definitions of LED states, see [Rear-Panel LEDs](#).

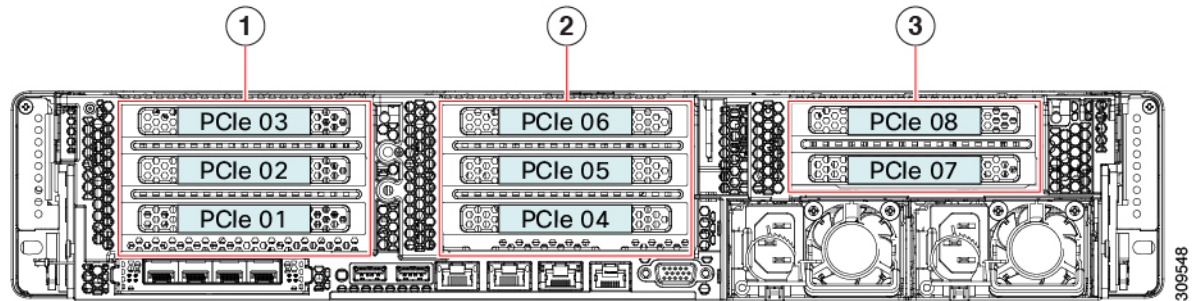

1	Riser 1A	2	Riser 2A
3	Riser 3A or 3C	-	

The following table shows the riser options for this version of the server.

Table 2: Cisco UCS C240 M6 12 SFF SAS/SATA (USC-C240M6-S)

Riser	Options
Riser 1 This riser is I/O-centric and controlled by CPU 1.	Riser 1A supports three PCIe slots numbered bottom to top: <ul style="list-style-type: none"> • Slot 1 is full-height, 3/4 length, x8, NCSI • Slot 2 is full-height, full-length, x16, NCSI • Slot 3 is full-height, full-length, x8, no NCSI
Riser 2 This riser is I/O-centric and controlled by CPU 2.	Riser 2A supports three PCIe slots: <ul style="list-style-type: none"> • Slot 4 is full-height, 3/4 length, x8, NCSI • Slot 5 is full-height, full-length, x16, NCSI • Slot 6 is full-height, full-length, x8, no NCSI

Riser	Options
<p>Riser 3</p> <p>This riser is I/O-centric and controlled by CPU 2.</p>	<p>Riser 3A supports two PCIe slots</p> <ul style="list-style-type: none"> • Slot 7 is full-height, full-length, x8, no NCSI • Slot 8 is full-height, full-length, x8, no NCSI • Riser 3C supports a GPU only. <ul style="list-style-type: none"> • Supports one full-height, full-length, double-wide GPU (PCIe slot 7 only), x16 • Slot 8 is blocked by double-wide GPU

Cisco UCS C240 M6 Server 24 NVMe Drive Rear Panel, I/O Centric

The Cisco UCS C240 M6 24 NVMe version has a rear configuration option, for either I/O (I/O Centric) or Storage (Storage Centric) with the I/O Centric version of the server offering PCIe slots and the Storage Centric version of the server offering drive bays.

The following illustration shows the rear panel features for the I/O Centric version of the Cisco UCS C240 M6SN.

- For features common to all versions of the server, see Common Rear Panel Features.
- For definitions of LED states, see [Rear-Panel LEDs](#).

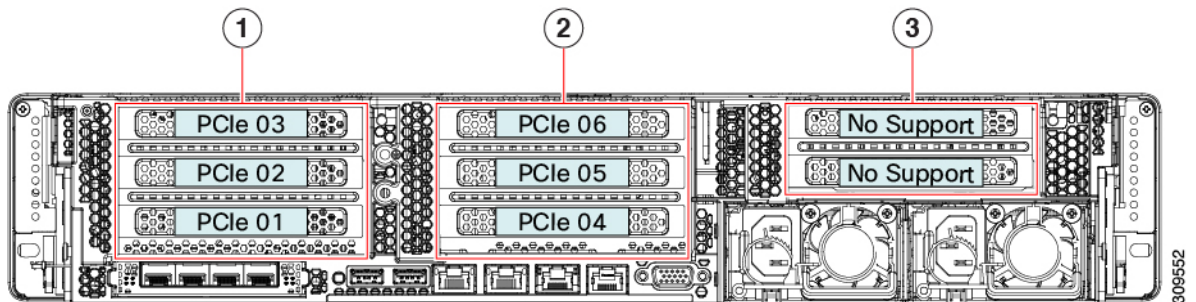

The following table shows the riser options for this version of the server.

1	Riser 1A	2	Riser 2A
3	Riser 3A, 3B, or 3C (not supported)	-	

Table 3: Cisco UCS C240 M6 24 SFF NVMe (UCSC-C240M6-SN)

Riser	Options
Riser 1 This riser is I/O-centric and controlled by CPU 1 or CPU 2.	Riser 1A supports three PCIe slots: <ul style="list-style-type: none"> Slot 1 is full-height, 3/4 length, x8, NCSI Slot 2 is full-height, full-length, x16, NCSI Slot 3 is full-height, full-length, x8, no NCSI
Riser 2A This riser is I/O-centric and controlled by CPU 2.	Riser 2A supports three PCIe slots: <ul style="list-style-type: none"> Slot 4 is full-height, 3/4 length, x8 Slot 5 is full-height, full-length, x16 Slot 6 is full-height, full-length, x8
Riser 3	Riser 3A, 3B, and 3C are not supported.

Cisco UCS C240 M6 Server 12 NVMe Drive Rear Panel, I/O Centric

The Cisco UCS C240 M6 24 NVMe version has a rear configuration option, for either I/O (I/O Centric) or Storage (Storage Centric) with the I/O Centric version of the server offering PCIe slots and the Storage Centric version of the server offering drive bays.

The following illustration shows the rear panel features for the I/O Centric version of the Cisco UCS C240 M6N.

- For features common to all versions of the server, see Common Rear Panel Features.
- For definitions of LED states, see [Rear-Panel LEDs](#).

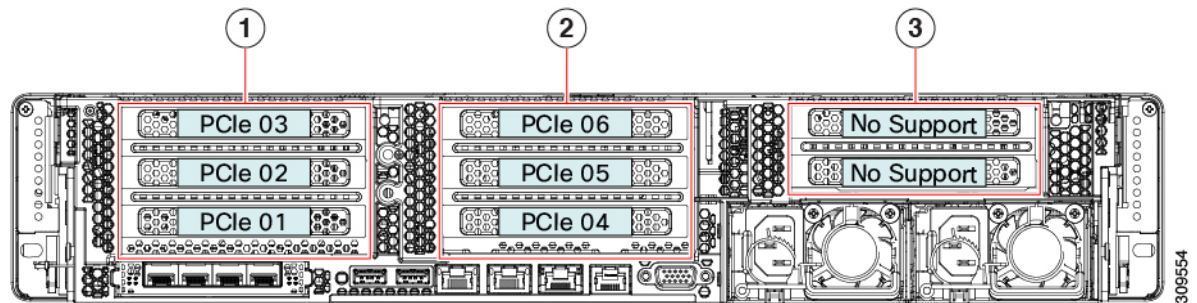

The following table shows the riser options for this version of the server.

1	Riser 1A	2	Riser 2A
3	Riser 3A, 3B, or 3C (Not Supported)	-	

Table 4: Cisco UCS C240 M6 24 SFF NVMe (UCSC-C240M6-SN)

Riser	Options
Riser 1 This riser is I/O-centric and controlled by CPU 1 or CPU 2.	Riser 1A supports three PCIe slots: <ul style="list-style-type: none"> Slot 1 is full-height, 3/4 length, x8, NCSI Slot 2 is full-height, full-length, x16, NCSI Slot 3 is full-height, full-length, x8, no NCSI
Riser 2A This riser is I/O-centric and controlled by CPU 2.	Riser 2A supports three PCIe slots: <ul style="list-style-type: none"> Slot 4 is full-height, 3/4 length, x8, NCSI Slot 5 is full-height, full-length, x16, NCSI Slot 6 is full-height, full-length, x8
Riser 3	Riser 3A, 3B, and 3C are not supported.

Cisco UCS C240 M6 Server 24 Drive Rear Panel, Storage Centric

The Cisco UCS C240 M6 24 SAS/SATA SFF version has a rear configuration option, for either I/O (I/O Centric) or Storage (Storage Centric) with the I/O Centric version of the server offering PCIe slots and the Storage Centric version of the server offering drive bays.

The following illustration shows the rear panel features for the Storage Centric version of the Cisco UCS C240 M6SX.

- For features common to all versions of the server, see Common Rear Panel Features.
- For definitions of LED states, see [Rear-Panel LEDs](#).

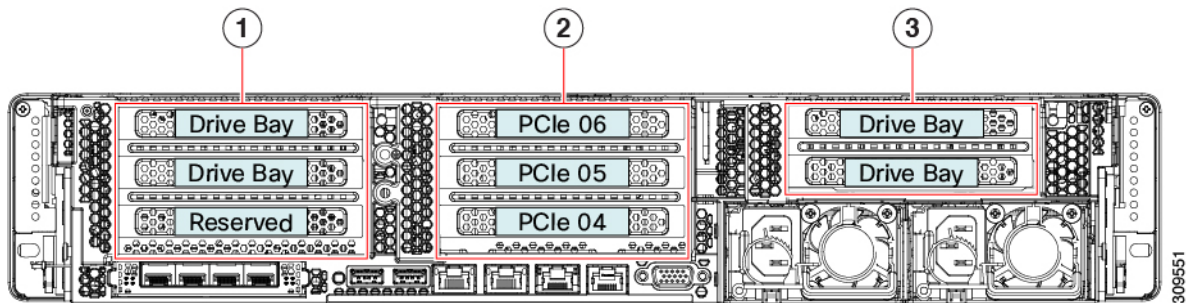

The following table shows the riser options for this version of the server.

1	Riser 1B	2	Riser 2A (Not supported)
3	Riser 3B, 3C	-	

Table 5: Cisco UCS C240 M6 24 SFF SAS/SATA/NVMe (UCSC-C240-M6SX)

Riser	Options
<p>Riser 1</p> <p>This riser is Storage-centric and controlled by CPU 2.</p>	<p>Riser 1B supports two SFF SAS/SATA/NVMe drives</p> <ul style="list-style-type: none"> • Slot 1 is reserved • Slot 2 (drive bay 102), x4 • Slot 3 (drive bay 101), x4 <p>When the server uses a hardware RAID controller card, SAS/SATA HDDs or SSDs, or NVMe PCIe SSDs are supported in the rear bays.</p>
<p>Riser 2</p> <p>This riser is I/O-centric and controlled by CPU 2.</p>	<p>Riser 2A is not supported for a Storage-centric version of the server.</p>
<p>Riser 3</p> <p>This riser is controlled by CPU 2.</p>	<p>Riser 3B has two PCIe slots that can support two SFF drives (NVMe).</p> <ul style="list-style-type: none"> • Slot 7 (drive bay 104), x4 • Slot 8 (drive bay 103), x4 <p>When the server uses a hardware RAID controller card, SAS/SATA HDDs or SSDs, or NVMe PCIe SSDs, are supported in the rear bays.</p> <p>Riser 3C has two PCIe slots that can support a GPU.</p> <ul style="list-style-type: none"> • Slot 7 supports one full-height, full-length, double-wide GPU, x16 • Slot 8 is blocked when a double-wide GPU is installed

Cisco UCS C240 M6 Server 12 Drive Rear Panel, Storage Centric

The Cisco UCS C240 M6 12 SAS/SATA SFF version has a rear configuration option, for either I/O (I/O Centric) or Storage (Storage Centric) with the I/O Centric version of the server offering PCIe slots and the Storage Centric version of the server offering drive bays.

The following illustration shows the rear panel features for the Storage Centric version of the Cisco UCS C240 M6S.

- For features common to all versions of the server, see Common Rear Panel Features.
- For definitions of LED states, see [Rear-Panel LEDs](#).

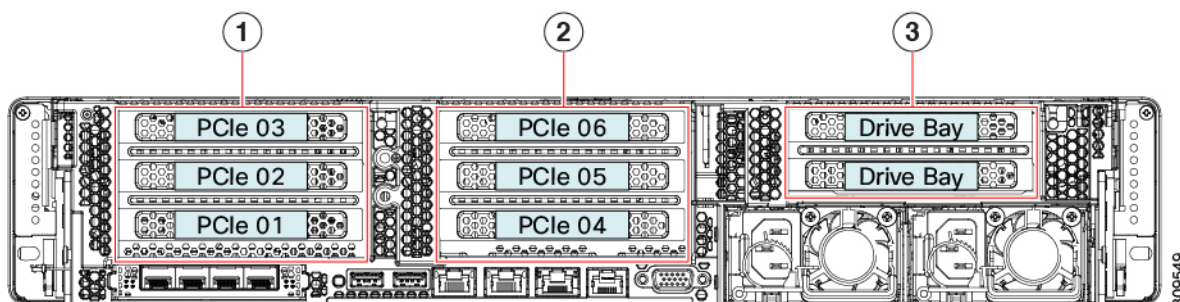

The following table shows the riser options for this version of the server.

1	Riser 1A	2	Riser 2A
3	Riser 3B, 3C	-	

Table 6: Cisco UCS C240 M6 12 SFF SAS/SATA (CSC-C240M6-S)

Riser	Options
Riser 1	Riser 1A is not supported for a Storage Centric version of the server.
Riser 2	Riser 2A is not supported for a Storage Centric version of the server.
Riser 3 This riser is Storage-centric and controlled by CPU 2.	<p>Riser 3B can support two SFF drives (SAS/SATA/NVMe):</p> <ul style="list-style-type: none"> • Slot 7 (drive bay 104), x4 • Slot 8 (drive bay 103), x4 <p>When you are using a HWRAID controller, SAS/SATA HDDs or SSDs, or NVME PCIe SSDs, are supported in the rear bays.</p> <p>Riser 3C has two PCIe slots that can support a GPU.</p> <ul style="list-style-type: none"> • Slot 7 supports one full-height, full-length, double-wide GPU, x16 • Slot 8 is blocked when a double-wide GPU is installed

Cisco UCS C240 M6 Server 24 NVMe Drive Rear Panel, Storage Centric

The Cisco UCS C240 M6 24 NVMe SFF version has a rear configuration option, for either I/O (I/O Centric) or Storage (Storage Centric) with the I/O Centric version of the server using PCIe slots and the Storage Centric version of the server offering drive bays.

The following illustration shows the rear panel features for the Storage Centric version of the Cisco UCS C240 M6SN.

- For features common to all versions of the server, see Common Rear Panel Features.
- For definitions of LED states, see [Rear-Panel LEDs](#).

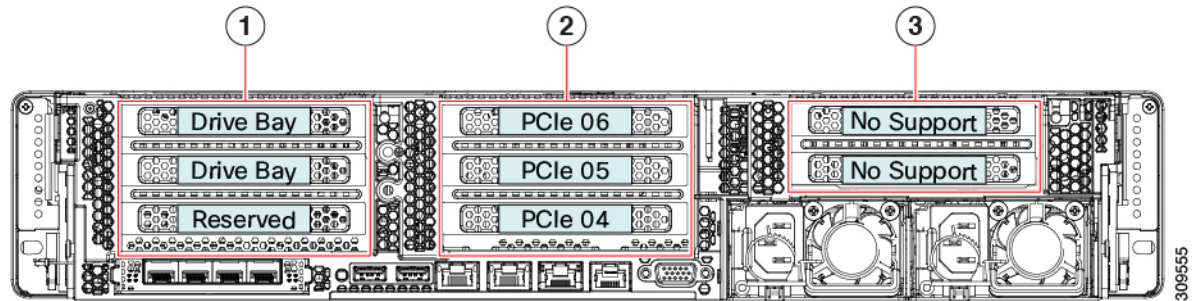

The following table shows the riser options for this version of the server.

1	Riser 1B	2	Riser 2A (Not Supported)
3	Riser 3A, 3B, or 3C (Not Supported)	-	

Table 7: Cisco UCS C240 M6 24 SFF NVMe (UCSC-C240M6-SN)

Riser	Options
Riser 1B This riser is Storage centric and controlled by CPU 2.	Riser 1B supports two NVMe drives: <ul style="list-style-type: none"> • Slot 1 is reserved • Slot 2 (drive bay 102), x4 • Slot 3 (drive bay 101), x4 When the server uses a hardware RAID controller card, NVMe PCIe SSDs are supported in the rear bays.
Riser 2	Riser 2A does not support storage devices.
Riser 3	Riser 3A, 3B, and 3C are not supported.

Cisco UCS C240 M6 Server 12 NVMe Drive Rear Panel, Storage Centric

The Cisco UCS C240 M6 12 NVMe SFF version has a rear configuration option, for either I/O (I/O Centric) or Storage (Storage Centric) with the I/O Centric version of the server using PCIe slots and the Storage Centric version of the server offering drive bays.

The following illustration shows the rear panel features for the Storage Centric version of the Cisco UCS C240 M6N.

- For features common to all versions of the server, see Common Rear Panel Features.
- For definitions of LED states, see [Rear-Panel LEDs](#).

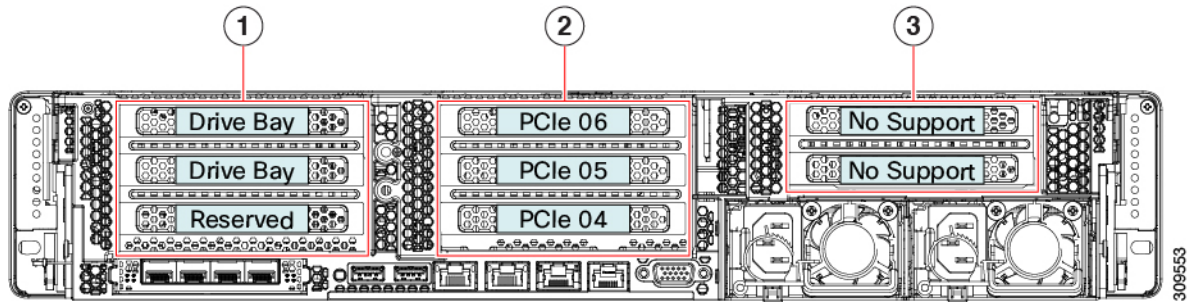

The following table shows the riser options for this version of the server.

1	Riser 1B	2	Riser 2A (Not Supported)
3	Riser 3A, 3B, or 3C (Not Supported)	-	

Table 8: Cisco UCS C240 M6 12 SFF NVMe (UCSC-C240-M6N)

Riser	Options
Riser 1B This riser is Storage-centric and controlled by CPU 2.	Riser 1B supports two NVMe drives: <ul style="list-style-type: none"> • Slot 1 is reserved • Slot 2 (drive bay 102), x4 • Slot 3 (drive bay 101), x4 When the server uses a hardware RAID controller card, NVMe PCIe SSDs are supported in the rear bays.
Riser 2	Riser 2A does not support storage devices.
Riser 3	Riser 3A, 3B, and 3C are not supported.

Cisco UCS C240 M6 Server 12 LFF Drive Rear Panel

Unlike the SFF versions of the server, the Cisco UCS C240 M6 LFF has one supported hardware configuration on the rear panel. The rear panel hardware configuration offers both PCIe slots and drive bays.

The following illustration shows the rear panel features for the I/O Centric version of the Cisco UCS C240 LFF.

- For features common to all versions of the server, see Common Rear Panel Features.
- For definitions of LED states, see [Rear-Panel LEDs](#).

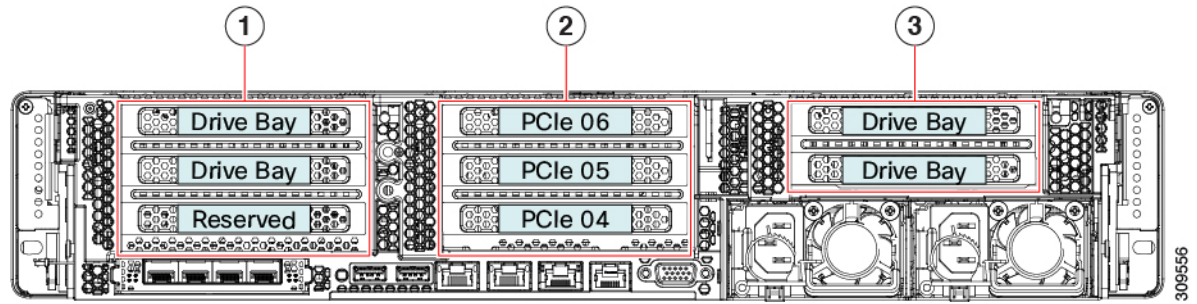

The following table shows the riser options for this version of the server.

1	Riser 1B	2	Riser 2A
3	Riser 3B	-	

Table 9: Cisco UCS C240 M6 12 LFF (UCSC-C240-LFF)

Riser	Options
<p>Riser 1</p> <p>This riser is controlled by CPU 1.</p>	<p>Riser 1B supports three PCIe slots numbered bottom to top.</p> <ul style="list-style-type: none"> Slot 1 is reserved for a drive controller. Slot 2 supports one drive (drive bay 102), x4 Slot 3 supports one drive (drive bay 101), x4 <p>When using a hardware RAID controller card or SAS</p> <p>When using a hardware RAID controller card or SAS HBA in the server, SAS/SATA HDDs or SSDs are supported in the rear bays.</p> <p>NVMe PCIe SSDs are supported in the rear bays without need for a RAID controller.</p>
<p>Riser 2</p> <p>This riser is controlled by CPU 2.</p>	<p>Riser 2A supports three PCIe slots:</p> <ul style="list-style-type: none"> Slot 4 is full-height, 3/4 length, x8 Slot 5 is full-height, full-length, x16 Slot 6 is full-height, full-length, x8

Riser	Options
<p>Riser 3</p> <p>This riser is controlled by CPU 2.</p>	<p>Riser 3B supports two drives:</p> <ul style="list-style-type: none"> • Slot 7 (drive bay 104), x4 • Slot 8 (drive bay 103), x4 <p>When the server uses a hardware RAID controller card or SAS HBA, SAS/SATA HDDs or SSDs are supported in the rear bays.</p> <p>NVMe PCIe SSDs are supported in the rear bays without need for a RAID controller</p>

PCle Risers

The following different PCIe riser options are available.

Riser 1 Options

This riser supports two options, Riser 1A and 1B.

PCIe Riser 1A (outside)

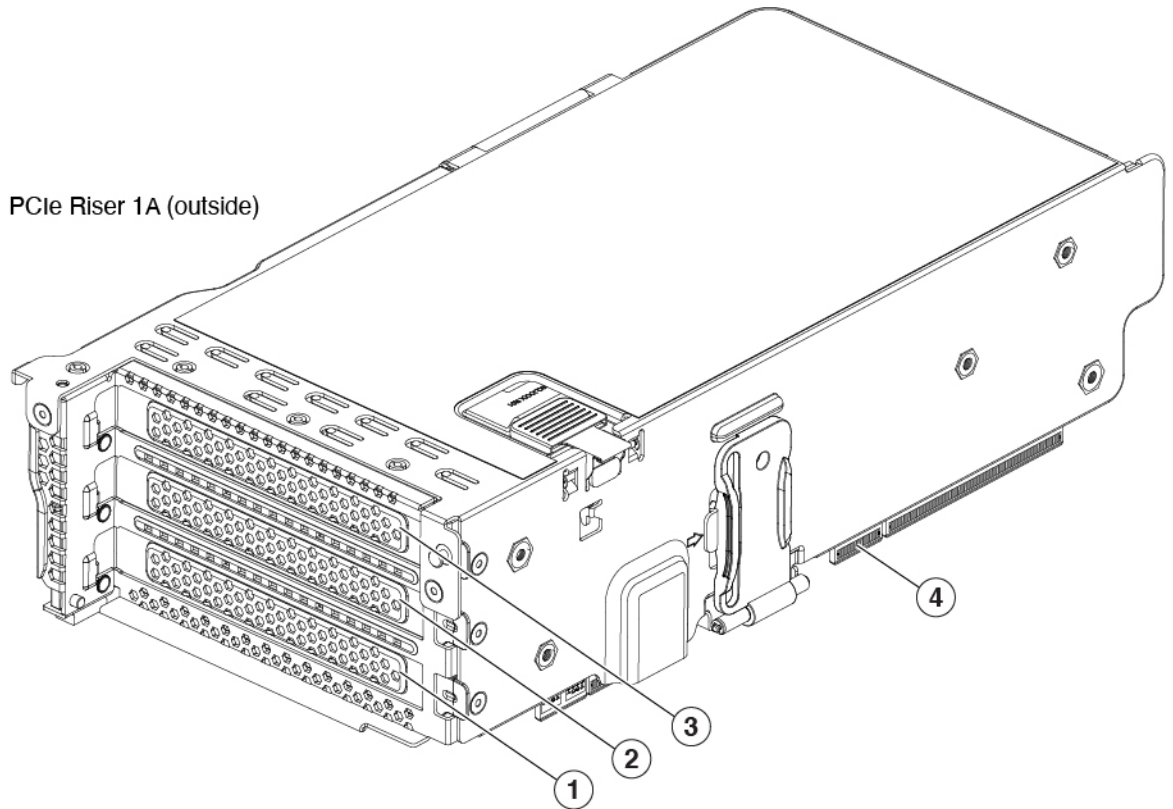

PCIe Riser 1A (inside)

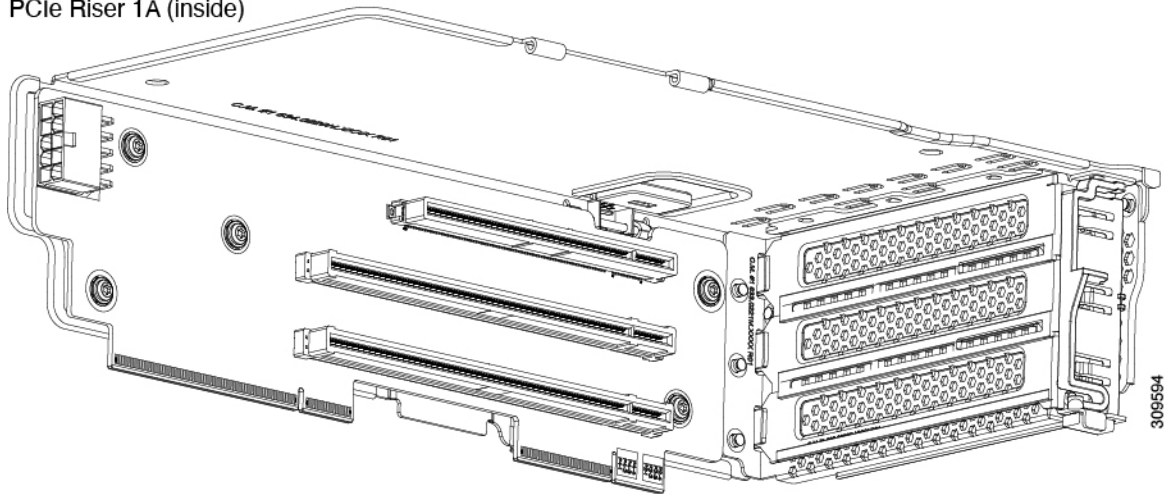

1	PCIe slot 1, Full height, ¾ length, x8, NCSI	2	PCIe slot 2, full height, full length, x16, NCSI, GPU capable
3	PCIe slot 3, full height, full length, x8, no NCSI	4	Edge Connectors

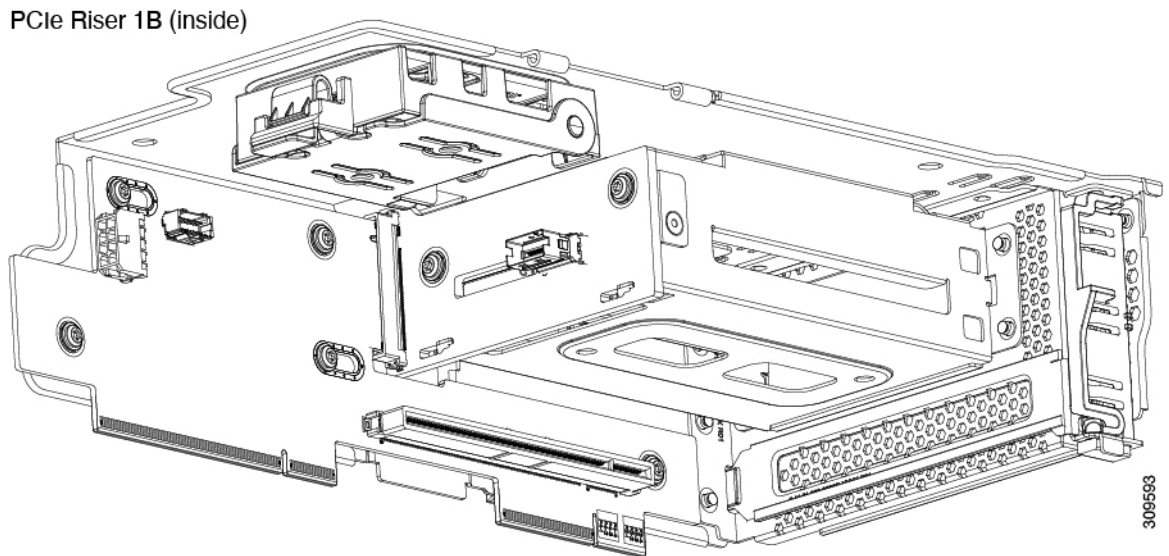
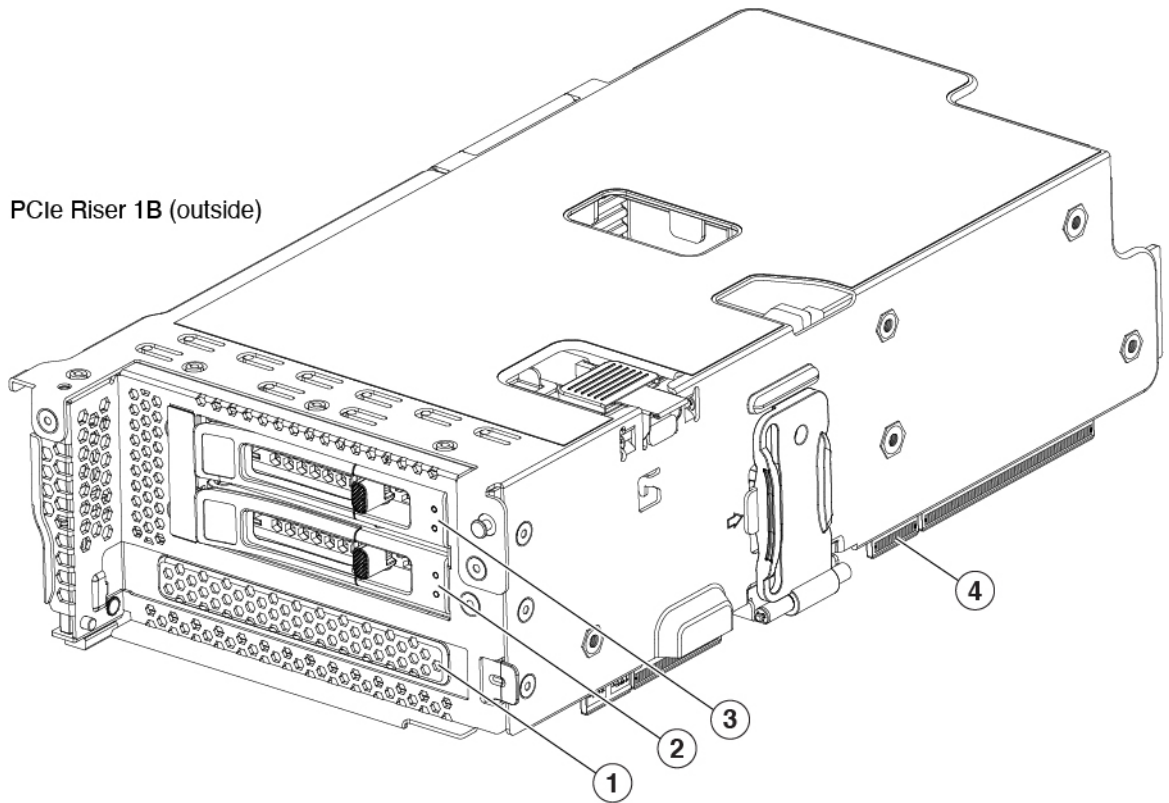

309593

1	PCIe slot 1, Reserved for drive controller	2	Drive Bay 102, x4
3	Drive 103, x4	4	Edge Connectors

Riser 2

This riser supports one option, Riser 2A.

PCIe Riser 2A (outside)

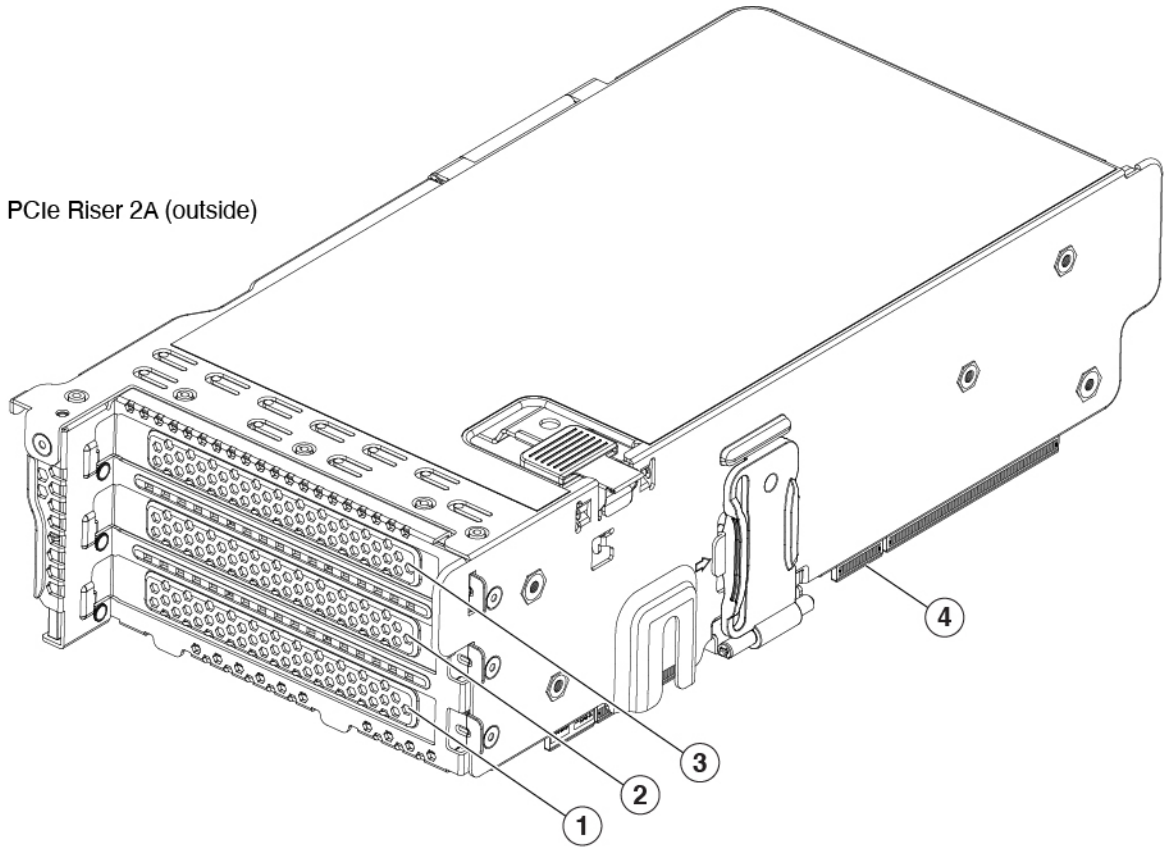

PCIe Riser 2A (inside)

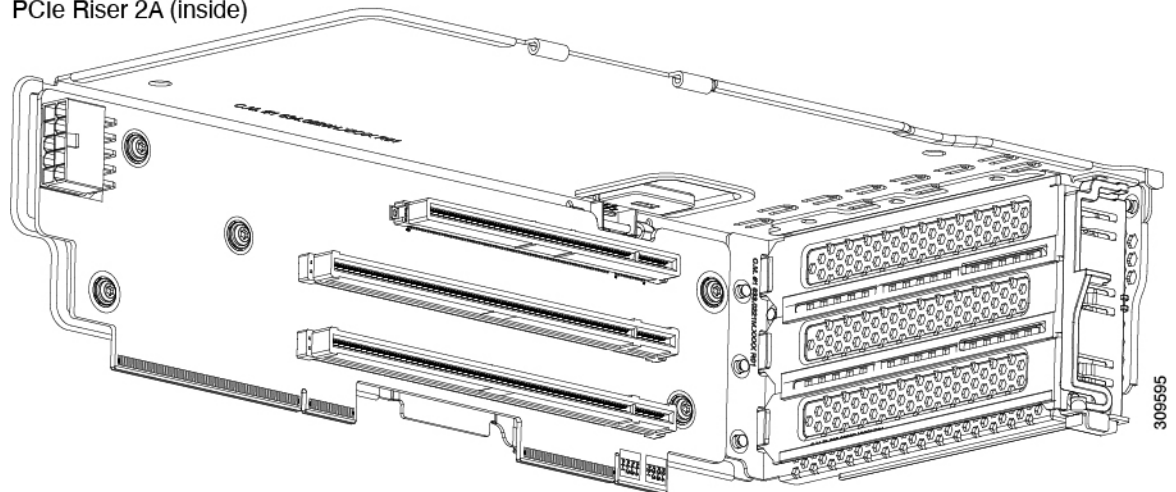

1	PCIe slot 4, Full height, ¾ length, x8	2	PCIe slot 5, full height, full length, x16
---	--	---	--

309595

3	PCIe slot 6, full height, full length, x16	4	Edge Connectors
---	--	---	-----------------

Riser 3

This riser supports three options, 3A, 3B, and 3C.

PCIe Riser 3A (outside)

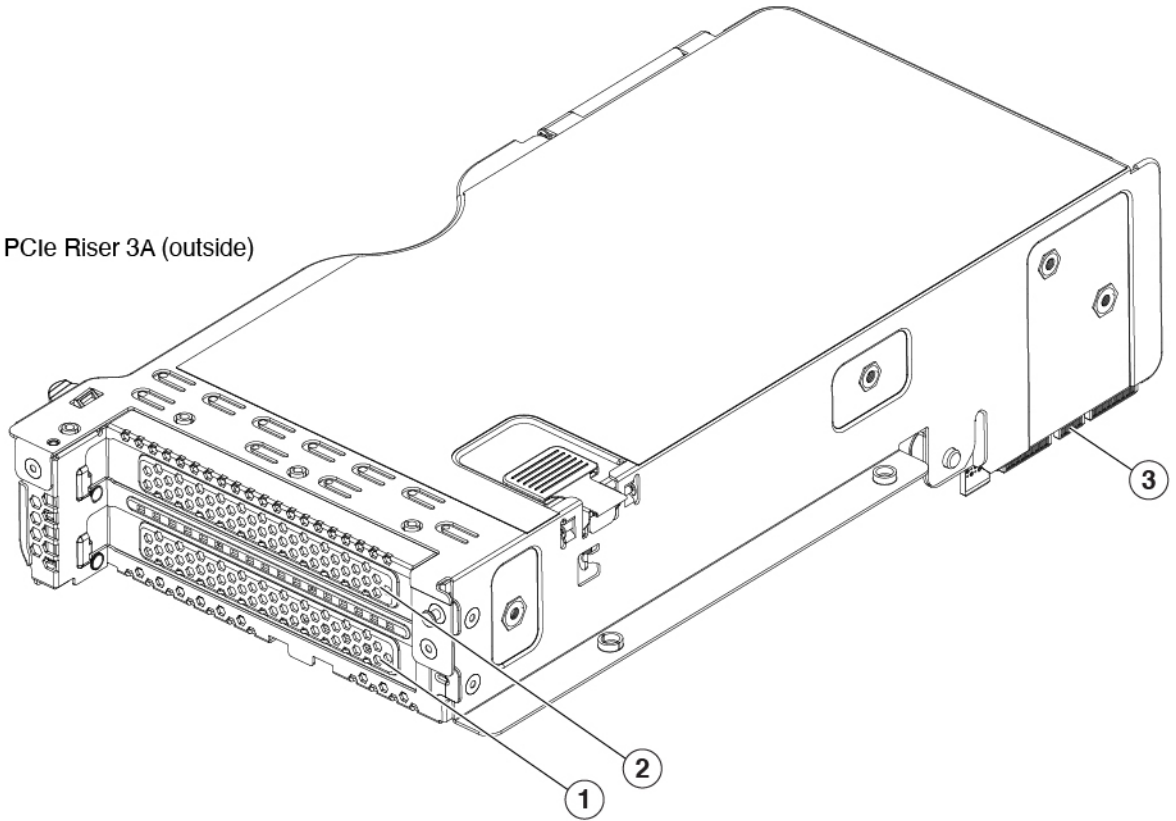

PCIe Riser 3A (inside)

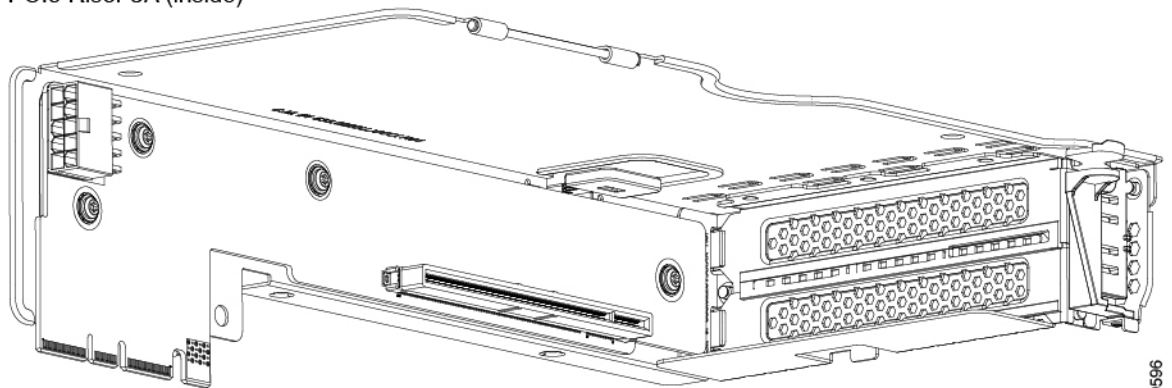

309596

1	PCIe slot 7, Full height, full length x8	2	PCIe slot 8, full height, full length, x16
3	Edge Connectors		

PCIe Riser 3B (outside)

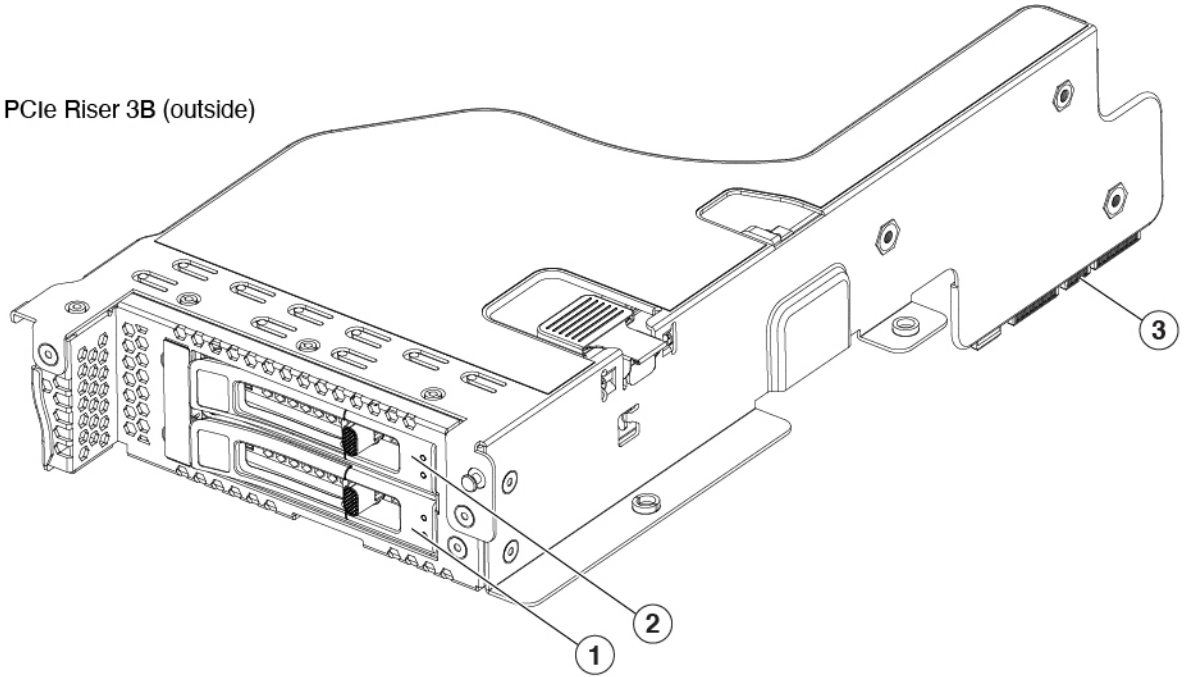

PCIe Riser 3B (inside)

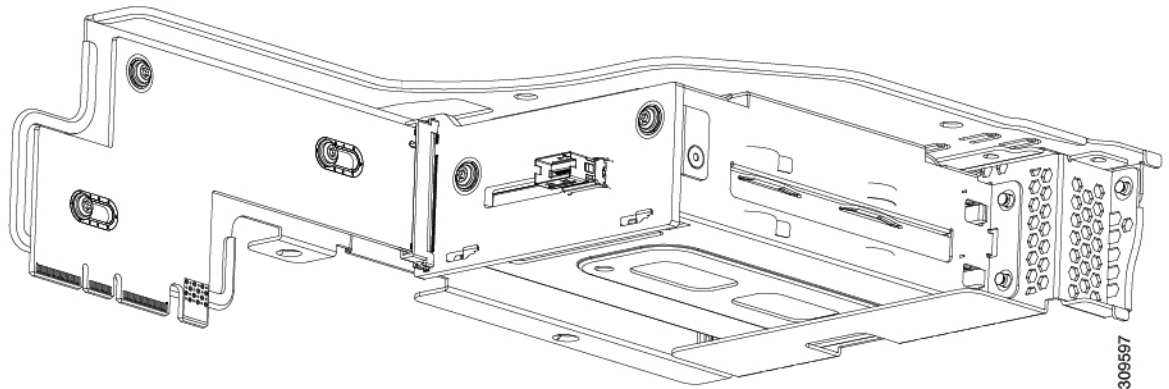

1	PCIe Slot 7, Drive Bay 103, x4	2	PCIe Slot 8, Drive Bay 103, x4
3	Edge Connectors		

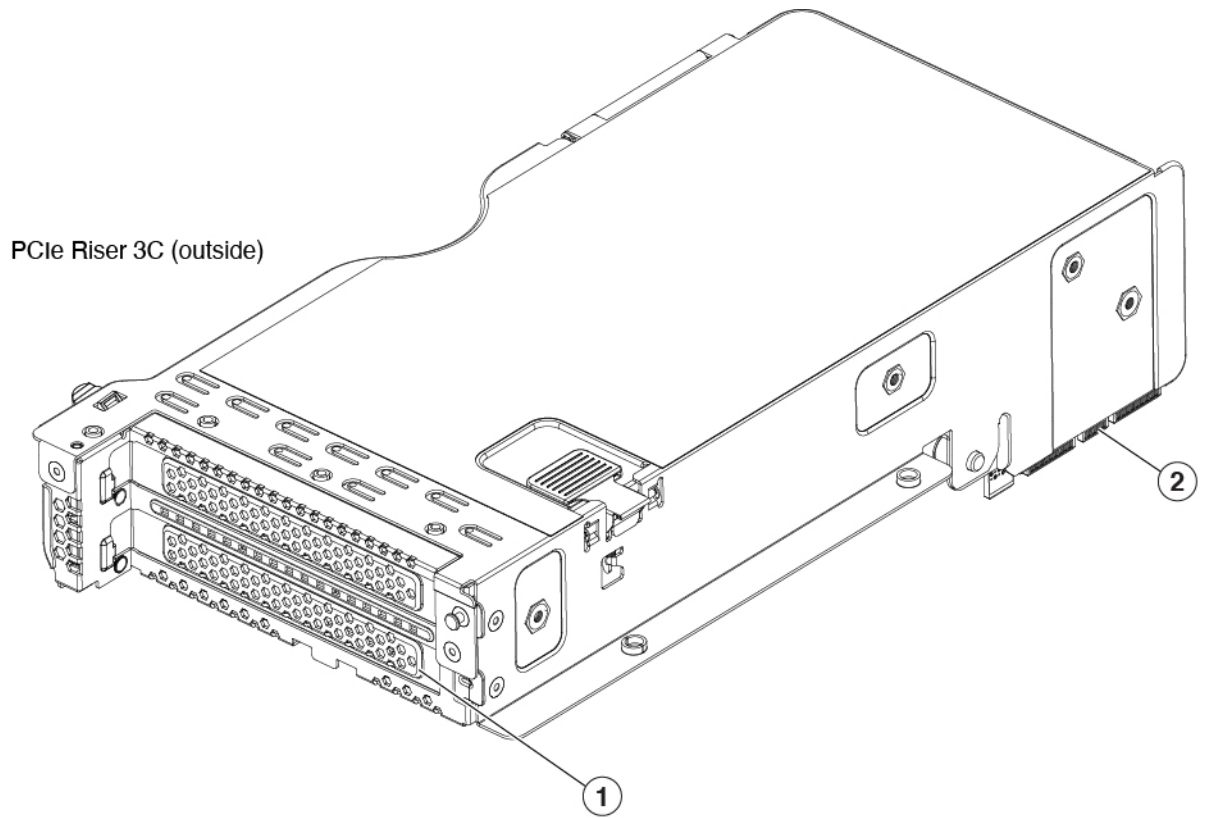

PCIe Riser 3C (inside)

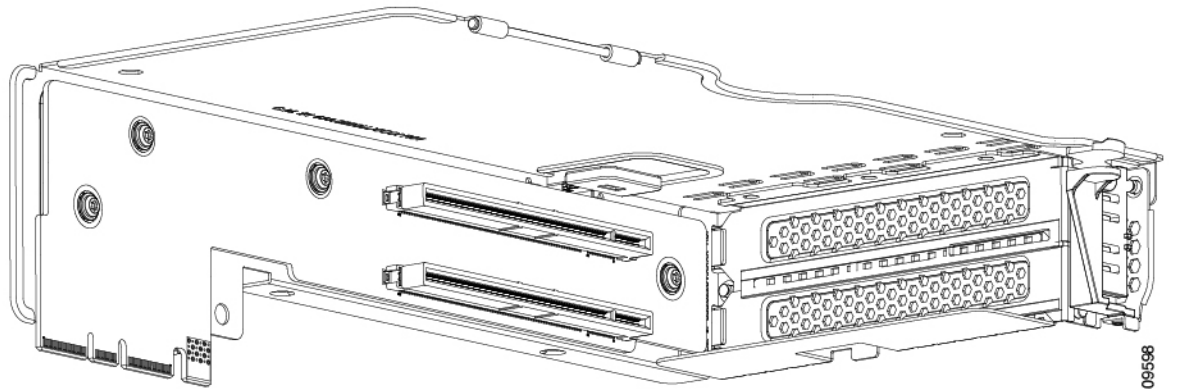

1	PCIe Slot 7, supports one full height, full length, double-wide GPU (slot 7 only), x16	2	Edge Connectors
---	--	---	-----------------

Summary of Server Features

The following tables list a summary of the server features for the LFF version and SFF versions of the server.

Table 10: Server Features, SFF

Feature	Description
Chassis	Two rack-unit (2RU) chassis
Central Processor	One or two 3rd Generation Intel Xeon processors.
Chipset	Intel® C621 series chipset
Memory	32 slots for registered DIMMs (RDIMMs) or load-reduced DIMMs (LR DIMMs) and support for Intel® Optane™ Persistent Memory Modules (DCPMMs)
Multi-bit error protection	Multi-bit error protection is supported
Video	<p>The Cisco Integrated Management Controller (CIMC) provides video using the Matrox G200e video/graphics controller:</p> <ul style="list-style-type: none"> • Integrated 2D graphics core with hardware acceleration • Embedded DDR memory interface supports up to 512 MB of addressable memory (8 MB is allocated by default to video memory) • Supports display resolutions up to 1920 x 1200 16bpp @ 60Hz • High-speed integrated 24-bit RAMDAC • Single lane PCI-Express host interface running at Gen 1 speed
Network and management I/O	<p>Rear panel:</p> <ul style="list-style-type: none"> • One 1-Gb Ethernet dedicated management port (RJ-45 connector) • Two 1-Gb/10-Gb BASE-T Ethernet LAN ports (RJ-45 connectors) <p>The dual LAN ports can support 1 Gbps and 10 Gbps, depending on the link partner capability.</p> <ul style="list-style-type: none"> • One RS-232 serial port (RJ-45 connector) • One VGA video connector port (DB-15 connector) • Two USB 3.0 ports <p>Front panel:</p> <ul style="list-style-type: none"> • One front-panel keyboard/video/mouse (KVM) connector that is used with the KVM breakout cable. The breakout cable provides two USB 2.0, one VGA, and one DB-9 serial connector.

Feature	Description
Power	<p>Up to two of the following hot-swappable power supplies:</p> <ul style="list-style-type: none"> • 1050 W (AC) • 1050 W (DC) • 1600 W (AC) • 2300 W (AC) <p>One power supply is mandatory; one more can be added for 1 + 1 redundancy as long power supplies are the same.</p> <p>For additional information, see Supported Power Supplies</p>
ACPI	The advanced configuration and power interface (ACPI) 4.0 standard is supported.
Front Panel	The front panel controller provides status indications and control buttons
Cooling	Six hot-swappable fan modules for front-to-rear cooling.
InfiniBand	The PCIe bus slots in this server support the InfiniBand architecture.
Expansion Slots	<p>For the SFF versions of the server, three half-height riser slots are supported:</p> <ul style="list-style-type: none"> • Riser 1A (3 PCIe slots) • Riser 1B (2 drive bays) • Riser 2A (3 PCIe slots) • Riser 3A (2 PCIe slots) • Riser 3B (2 drive bays) • Riser 3C (1 full-length, double-wide GPU) <p>Note Not all risers are available in every server configuration option.</p> <p>One or two dedicated slots (depending on the server type) for a SATA interposer or storage controller(s).</p>

Feature	Description
Interfaces	<p>Rear panel:</p> <ul style="list-style-type: none">• One 1Gbase-T RJ-45 management port• Two 10Gbase-T LOM ports• One RS-232 serial port (RJ45 connector)• One DB15 VGA connector• Two USB 3.0 port connectors• One flexible modular LAN on motherboard (mLOM) slot that can accommodate various interface cards <p>Front panel supports one KVM console connector that supplies:</p> <ul style="list-style-type: none">• two USB 2.0 connectors,• one VGA DB15 video connector• one serial port (RS232) RJ45 connector

Feature	Description
Internal Storage Devices	<ul style="list-style-type: none"> • UCSC-C240-M6S: <ul style="list-style-type: none"> • Up to 12 SFF SAS/SATA hard drives (HDDs) or SAS/SATA solid state drives (SSDs) • Optionally, up to four SFF NVMe PCIe SSDs. These drives must be placed in front drive bays 1, 2, 3, and 4 only, can be mixed with SAS/SATA drives. The rest of the bays (5 - 12) can be populated with SAS/SATA SSDs or HDDs. Two CPUs are required in a server that has any number of NVMe drives. • Optionally, one front-facing DVD drive • Optionally, up to two SFF rear-facing SAS/SATA/NVMe drives • If using a SATA Interposer, up to 8 SATA-only drives can be installed (slots 1-8 only). • UCSC-C240-M6SX: <ul style="list-style-type: none"> • Up to 24 front SFF SAS/SATA hard drives (HDDs) or SAS/SATA solid state drives (SSDs). • Optionally, up to four front SFF NVMe PCIe SSDs. These drives must be placed in front drive bays 1, 2, 3, and 4 only. The rest of the bays (5 - 24) can be populated with SAS/SATA SSDs or HDDs. Two CPUs are required in a server that has any number of NVMe drives. • Optionally, up to four SFF rear-facing SAS/SATA/NVMe drives • UCSC-C240-M6N: <ul style="list-style-type: none"> • Up to 12 front NVMe (only) drives • Optionally, up to 2 rear NVMe (only) drives • Two CPUs are required in a server that has any number of NVMe drives. • UCSC-C240-M6SN: <ul style="list-style-type: none"> • Up to 24 front NVMe drives (only). • Optionally, up to 2 rear NVMe drives (only) • Two CPUs are required when choosing NVMe SSDs • Other Storage: <ul style="list-style-type: none"> • A mini-storage module connector on the motherboard supports a boot-optimized RAID controller carrier that holds up two SATA M.2 SSDs. Mixing different capacity SATA M.2 SSDs is not supported. • Optional 2 M.2 RAID cards for use as boot volumes.

Feature	Description
Integrated Management Processor	<p>Baseboard Management Controller (BMC) running Cisco Integrated Management Controller (CIMC) firmware.</p> <p>Depending on your CIMC settings, the CIMC can be accessed through the 1GE dedicated management port, the 1GE/10GE LOM ports, or a Cisco virtual interface card (VIC).</p> <p>CIMC manages certain components within the server, such as the Cisco 12G SAS HBA.</p>
Storage Controllers	<p>One SATA Interposer board, 12G RAID HBA, or one or two 12G SAS HBAs plug into a dedicated slot.</p> <ul style="list-style-type: none"> • SATA Interposer board: <ul style="list-style-type: none"> • AHCI support for up to eight SATA-only drives (slots 1- 8) • Supported only on the UCSC-C240M6-S server • Cisco 12G RAID controller with 4GB FBWC (for UCSC-240-M6S server) <ul style="list-style-type: none"> • RAID support (RAID 0, 1, 5, 6, 10, 50 and 60) and SW RAID0 • Supports up to 14 internal SAS/SATA drives • Cisco M6 12G SAS RAID controller with 4GB FBWC (for UCSC-240-M6SX server) <ul style="list-style-type: none"> • RAID support (RAID 0, 1, 5, 6, 10, 50, and 60) and SRAID0 • Supports up to 28 internal SAS/SATA drives • Cisco M6 12G SAS HBA (for UCSC-240-M6S and UCSC-240-M6SX servers) <ul style="list-style-type: none"> • RAID Support 0, 1, and 10 • JBOD/Pass-through Mode support • Each HBA supports up to 14 SAS/SATA internal drives
Modular LAN over Motherboard (mLOM) slot	The dedicated mLOM slot on the motherboard can flexibly accommodate Cisco Virtual Interface Cards (VICs).
Server Management	Cisco Intersight provides server management.
CIMC	Cisco Integrated Management Controller (CIMC) 4.2(1) or later is required for the server.

Table 11: Server Features, LFF

Feature	Description
Chassis	Two rack-unit (2RU) chassis
Central Processor	One or two 3rd Generation Intel Xeon processors.
Chipset	Intel® C621 series chipset

Feature	Description
Memory	32 slots for registered DIMMs (RDIMMs) or load-reduced DIMMs (LR DIMMs) and support for Intel® Optane™ Persistent Memory Modules (DCPMMs)
Multi-bit error protection	Multi-bit error protection is supported
Video	<p>The Cisco Integrated Management Controller (CIMC) provides video using the Matrox G200e video/graphics controller:</p> <ul style="list-style-type: none"> • Integrated 2D graphics core with hardware acceleration • DDR2/3 memory interface supports up to 512 MB of addressable memory (8 MB is allocated by default to video memory) • Supports display resolutions up to 1920 x 1200 16bpp @ 60Hz • High-speed integrated 24-bit RAMDAC • Single lane PCI-Express host interface running at Gen 1 speed
Network and management I/O	<p>Rear panel:</p> <ul style="list-style-type: none"> • One 1Gbase-T RJ-45 management port • Two 10Gbase-T LOM ports • One RS-232 serial port (RJ-45 connector) • One DB15 VGA connector • Two USB 3.0 ports • One flexible modular LAN on motherboard (mLOM) slot that can accommodate various interface cards <p>Front panel supports one KVM console connector that supplies:</p> <ul style="list-style-type: none"> • two USB 2.0 connectors, • one VGA DB15 video connector • one serial port (RS232) RJ45 connector
Power	<p>Up to two of the following hot-swappable power supplies:</p> <ul style="list-style-type: none"> • 1050 W (AC) • 1050 W (DC) • 1600 W (AC) • 2300 W (AC) <p>One power supply is mandatory; one more can be added for 1 + 1 redundancy. With two power supplies, both must be the same type and wattage.</p>
ACPI	The advanced configuration and power interface (ACPI) 4.0 standard is supported.

Feature	Description
Front Panel	The front panel controller provides status indications and control buttons
Cooling	Six hot-swappable fan modules for front-to-rear cooling.
InfiniBand	The PCIe bus slots in this server support the InfiniBand architecture.
Expansion Slots	<ul style="list-style-type: none"> • Riser 1B (1 PCIe slot reserved for a drive controller and 2 HDD slots) • Riser 2A (3 PCIe slots) • Riser 3B (2 HDD slots)
Interfaces	<p>Rear panel:</p> <ul style="list-style-type: none"> • One 1Gbase-T RJ-45 management port • Two 10Gbase-T LOM ports • One RS-232 serial port (RJ45 connector) • One DB15 VGA connector • Two USB 3.0 port connectors • One flexible modular LAN on motherboard (mLOM) slot that can accommodate various interface cards <p>Front panel: Supports one KVM console connector that supplies two USB 2.0 connectors, one VGA DB15 video connector, and one serial port (RS232) RJ45 connector</p>
Internal Storage Devices	<ul style="list-style-type: none"> • Large Form Factor (LFF) drives with a 12-drive backplane. The server can hold a maximum of: <ul style="list-style-type: none"> • 12 LFF 3.5-inch front-loading SAS-only hard drives (HDDs, 4 mid-plane LFF drives, • As an option, up to four 3.5-inch mid-plane SAS-only LFF HDDs • Optionally, up to four rear-facing SAS/SATA HDDs/SSDs or up to four rear-facing NVMe PCIe SSDs • A mini-storage module connector on the motherboard supports a boot-optimized RAID controller carrier that holds up two SATA M.2 SSDs. Mixing different capacity SATA M.2 SSDs is not supported.

Feature	Description
Storage Controllers	<p>The 12G RAID HBA or 12G SAS HBA plugs into slot 1 (bottom slot) of riser 1B.</p> <ul style="list-style-type: none"> • Cisco M6 12G SAS RAID Controller with 4GB FBWC <ul style="list-style-type: none"> • RAID support (RAID 0, 1, 5, 6, 10, 50 and 60) and SRAID • Supports up to 32 internal SAS/SATA drives • Plugs into drive slot 1 of riser 1B • Cisco M6 12G SAS HBA <ul style="list-style-type: none"> • RAID 0, 1, and 10 support • JBOD/Pass-through Mode support • Supports up to 32 SAS/SATA internal drives • Plugs into slot 1 of riser 1B
Integrated Management Processor	<p>Baseboard Management Controller (BMC) running Cisco Integrated Management Controller (CIMC) firmware.</p> <p>Depending on your CIMC settings, the CIMC can be accessed through the 1GE dedicated management port, the 1GE/10GE LOM ports, or a Cisco virtual interface card (VIC).</p> <p>CIMC manages certain components within the server, such as the Cisco 12G SAS HBA.</p>
Modular LAN over Motherboard (mLOM) slot	<p>The dedicated mLOM slot on the motherboard can flexibly accommodate Cisco Virtual Interface Cards (VICs).</p>
Server Management	<p>Cisco Intersight provides server management.</p>
CIMC	<p>Cisco Integrated Management Controller 4.2(1) or later is required for this server.</p>

Serviceable Component Locations

This topic shows the locations of the field-replaceable components and service-related items. The view in the following figure shows the server with the top cover removed.

Figure 7: Cisco UCS C240 M6 Server, Serviceable Component Locations

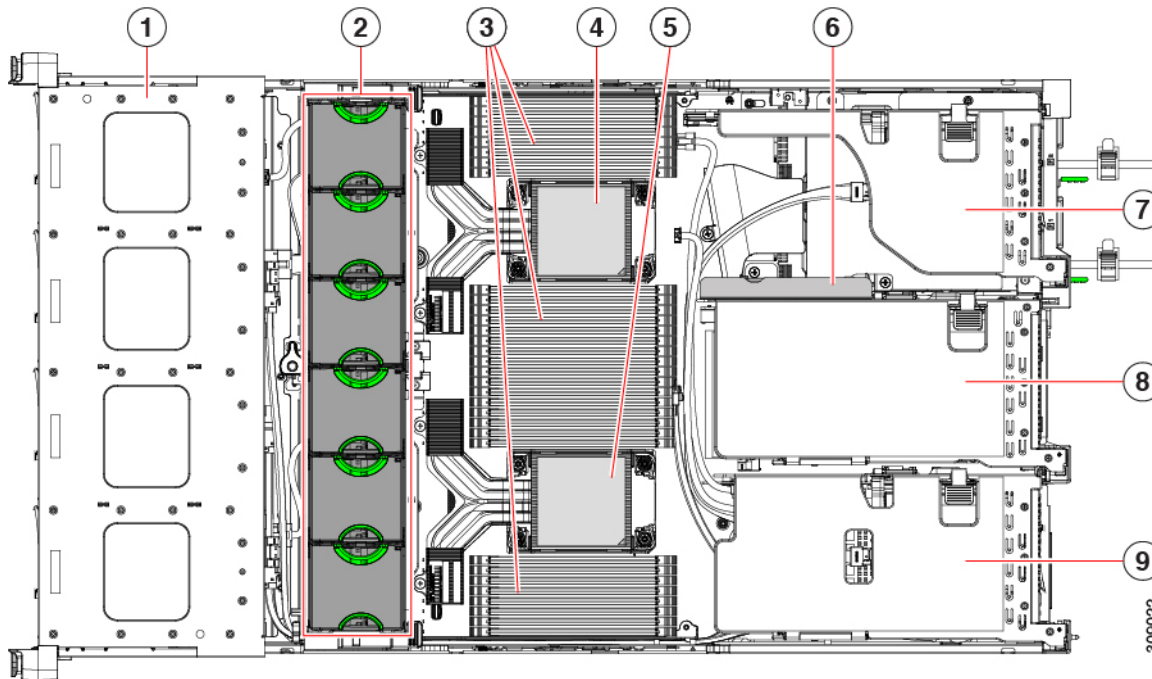

1	Front-loading drive bays.	2	Cooling fan modules (six, hot-swappable)
3	<p>DIMM sockets on motherboard (16 per CPU)</p> <p>See DIMM Population Rules and Memory Performance Guidelines for DIMM slot numbering.</p> <p>Note An air baffle rests on top of the DIMM and CPUs when the server is operating. The air baffle is not displayed in this illustration.</p>	4	CPU socket 1
5	CPU socket 2	6	M.2 RAID Controller
7	<p>PCIe riser 3 (PCIe slots 7 and 8 numbered from bottom to top), with the following options:</p> <ul style="list-style-type: none"> • 3A (Default Option)—Slots 7 (x16 mechanical, x8 electrical), and 8 (x16 mechanical, x8 electrical). Both slots can accept a full height, full length GPU card. • 3B (Storage Option)—Slots 7 (x24 mechanical, x4 electrical) and 8 (x24 mechanical, x4 electrical). Both slots can accept 2.5-inch SFF universal HDDs. • 3C (GPU Option)—Slots 7 (x16 mechanical, x16 electrical) and 8 empty (NCSI support limited to one slot at a time). Slot 7 can support a full height, full length GPU card. 	8	<p>PCIe riser 2 (PCIe slots 4, 5, 6 numbered from bottom to top), with the following options:</p> <ul style="list-style-type: none"> • 2A (Default Option)—Slot 4 (x24 mechanical, x8 electrical) supports full height, ¾ length card; Slot 5 (x24 mechanical, x16 electrical) supports full height, full length GPU card; Slot 6 (x16 mechanical, x8 electrical) supports full height, full length card.

9	<p>PCIe riser 1 (PCIe slot 1, 2, 3 numbered bottom to top), with the following options:</p> <ul style="list-style-type: none"> • 1A (Default Option)—Slot 1 (x24 mechanical, x8 electrical) supports full height, ¾ length card; Slot 2 (x24 mechanical, x16 electrical) supports full height, full length GPU card; Slot 3 (x16 mechanical, x8 electrical) supports full height, full length card. • 1B (Storage Option)—Slot 1 (x24 mechanical, x8 electrical) supports full height, ¾ length card; Slot 2 (x4 electrical), supports 2.5-inch SFF universal HDD; Slot 3 (x4 electrical), supports 2.5-inch SFF universal HDD <p>Note The chassis supports an internal USB drive (not shown) at this PCIe slot. See Replacing a USB Drive.</p>	-	
---	--	---	--

The Technical Specifications Sheets for all versions of this server, which include supported component part numbers, are at [Cisco UCS Servers Technical Specifications Sheets](#) (scroll down to *Technical Specifications*).