



Recycling Server Components

This chapter contains the following topics:

- [Server Recycling and E-Waste, on page 1](#)
- [Battery Warning, on page 1](#)
- [Recycling the Main Motherboard PCB Assembly \(PCBA\), on page 1](#)
- [Recycling the Front Mezzanine Module PCBA \(NVMe Backplane\) , on page 3](#)
- [Recycling the Front Mezzanine Module PCBA \(SAS Backplane\) , on page 5](#)
- [Recycling the Server Front Panel PCBA, on page 7](#)

Server Recycling and E-Waste

The server has various components that can be recycled. When recycling the server and its components, always comply with your local laws governing recycling and e-waste.



Warning

The procedures in this chapter are destructive and can render the server unusable, so this content is not for standard use or FRU procedures! These procedures are for recyclers only.

Battery Warning

The server has a round button-style battery which is used for the real-time clock.



Warning

Recyclers: Do not shred the battery! Make sure you dispose of the battery according to appropriate regulations for your country or locale.

For information about removing the battery, see [Replacing the RTC Battery](#).

Recycling the Main Motherboard PCB Assembly (PCBA)

The PCBA is secured to the server's sheet metal through the following:

- 13 M3.5x0.6mm Torx screws.
- 2 M3.5x0.6mm Torx thumb screws.

You must disconnect the PCBA from the tray before recycling the PCBA.

Before you begin



Note **For Recyclers Only!** This procedure is not a standard field-service option. This procedure is for recyclers who will be reclaiming the electronics for proper disposal to comply with local eco design and e-waste regulations.

To remove the printed circuit board assembly (PCBA), the following requirements must be met:

- The server must be disconnected from facility power.
- The server must be removed from the equipment rack.
- The server's top cover must be removed. See [Removing Top Cover](#).

Gather the following tools before you start this procedure:

- Pliers
- T10 Torx screwdriver

-
- Step 1** If you have not removed the TPM module, do so now.
- Step 2** When the TPM module is detached, locate the PCBA's screws.
- The following figure shows the location of the screws.

Figure 1: Screw Locations for Removing the PCBA

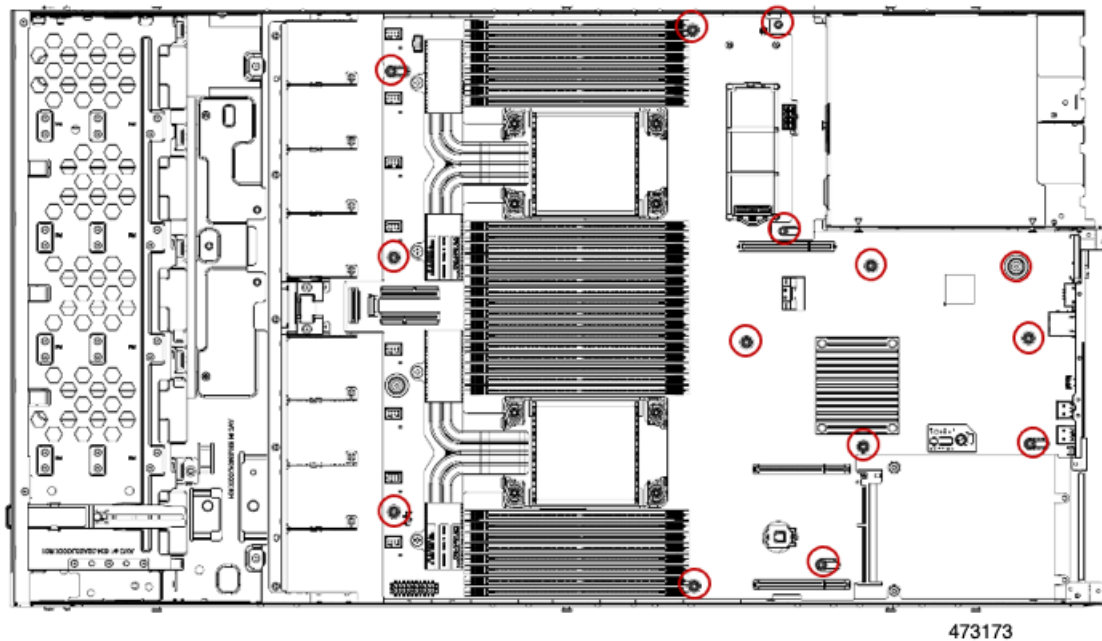

- Step 3** Using a T10 Torx driver, remove all of the indicated screws.
- Step 4** Remove the PCBA and dispose of it properly.

Recycling the Front Mezzanine Module PCBA (NVMe Backplane)

The server's front mezzanine module contains one PCBA, which is the vertical PCB for the NVMe drive backplane. The PCBA is attached to the server's sheetmetal by ten T10 screws.

You must disconnect the PCBA from the sheetmetal before recycling the PCBA.

Before you begin



Note For Recyclers Only! This procedure is not a standard field-service option. This procedure is for recyclers who will be reclaiming the electronics for proper disposal to comply with local eco design and e-waste regulations.

To remove the printed circuit board assembly (PCBA), the following requirements must be met:

- The server must be disconnected from facility power.
- The server must be removed from the equipment rack.
- The server's top cover must be removed. See [Removing Top Cover](#).

Gather a T10 Torx screwdriver.

Step 1 Using a T10 Torx driver, remove the screws that secure the front mezzanine module to the server chassis.

There are total of six T10 screws:

- Two on each exterior sidewall of the server chassis. These screws are on the sheetmetal crease for the top cover.
- Two on the interior of the front mezzanine module.

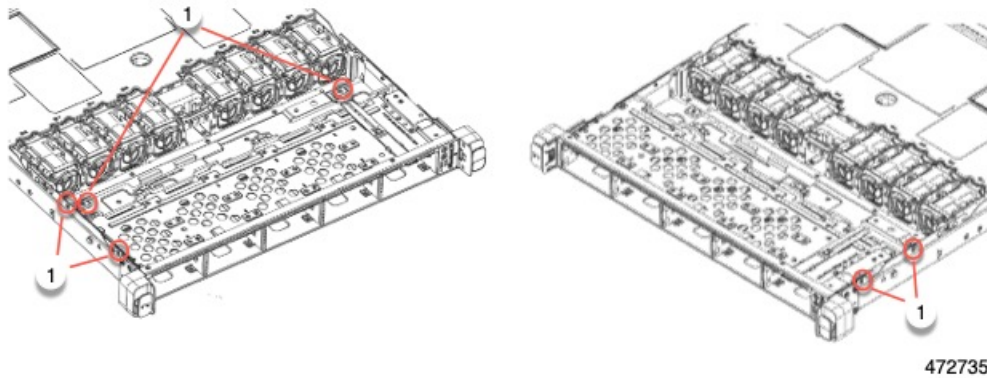

Step 2 Grasp the front mezzanine module and slide it out of the server chassis.

If the module does not slide out, verify that all of the T10 screws are removed.

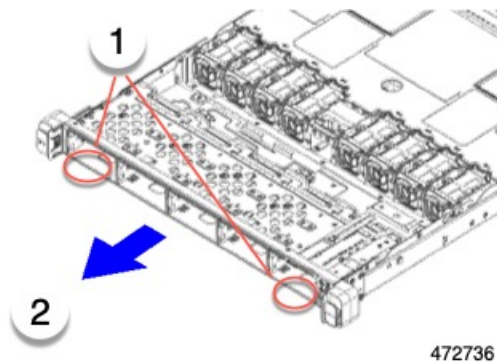

Step 3 Disconnect the vertical drive backplane.

- a) Using a T10 Torx driver, remove the four screws on the vertical drive backplane.

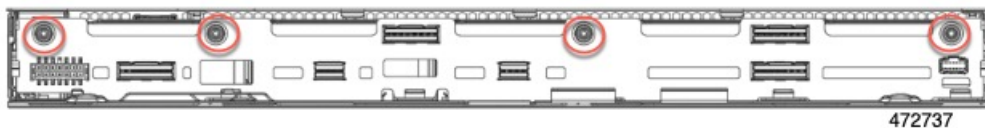

- b) Grasp the drive backplane and disconnect it from the module.

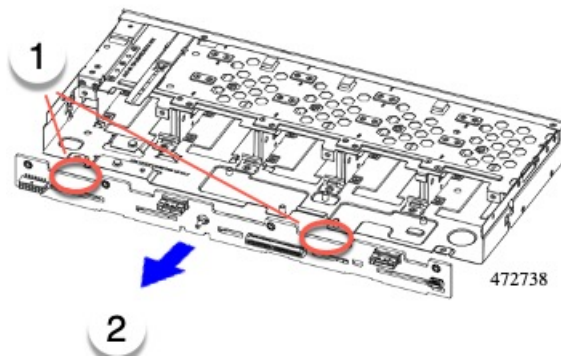

Step 4 Remove the PCBA and dispose of it properly in accordance with your local recycling and e-waste laws.

What to do next

Recycle the server front panel.

Recycling the Front Mezzanine Module PCBA (SAS Backplane)

The server's front mezzanine module contains one PCBA, which is the vertical PCB for the SAS drive backplane. The PCBA is attached to the server's sheetmetal by 15 T10 screws.

You must disconnect the PCBA from the sheetmetal before recycling the PCBA.

Before you begin



Note For Recyclers Only! This procedure is not a standard field-service option. This procedure is for recyclers who will be reclaiming the electronics for proper disposal to comply with local eco design and e-waste regulations.

To remove the printed circuit board assembly (PCBA), the following requirements must be met:

- The server must be disconnected from facility power.
- The server must be removed from the equipment rack.
- The server's top cover must be removed. See [Removing Top Cover](#).

Gather a T10 Torx screwdriver.

Step 1 Using a T10 Torx driver, remove the screws that secure the front mezzanine module to the server chassis.

There are total of six T10 screws:

- Two on each exterior sidewall of the server chassis. These screws are on the sheetmetal crease for the top cover.
- Two on the interior of the front mezzanine module.

Recycling the Front Mezzanine Module PCBA (SAS Backplane)

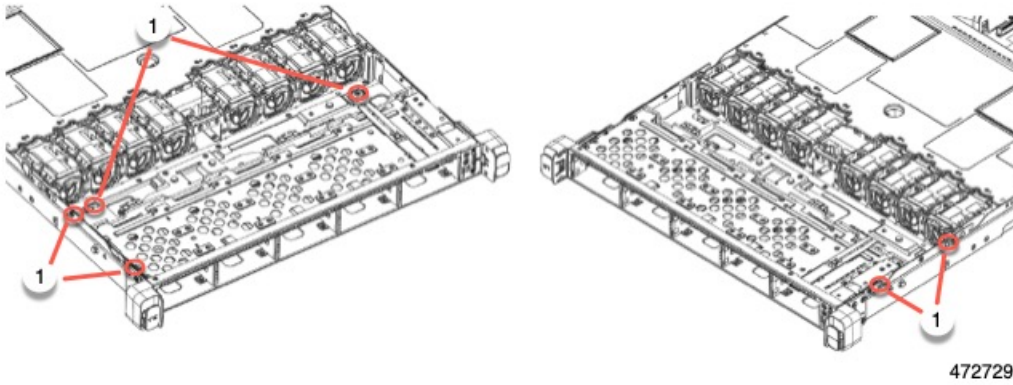

- Step 2** Grasp the front mezzanine module and slide it out of the server chassis.
If the module does not slide out, verify that all of the T10 screws are removed.

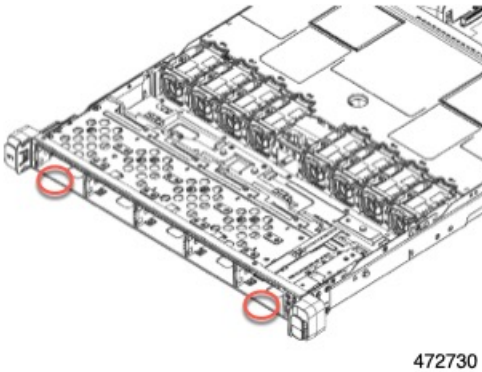

- Step 3** Remove the bracket at the rear of the front mezzanine module.
a) Using the T10 screwdriver, remove the five screws that secure the bracket at the rear of the module.

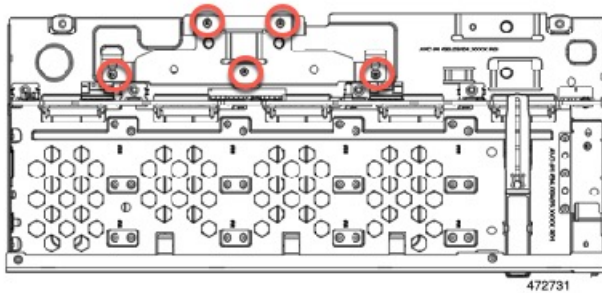

- b) Grasp the bracket and lift it off of the module.

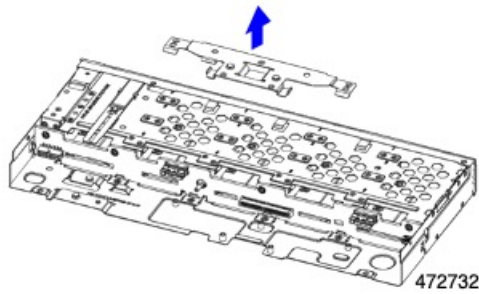
**Step 4**

Disconnect the vertical drive backplane.

- a) Using a T10 Torx driver, remove the four screws on the vertical drive backplane.

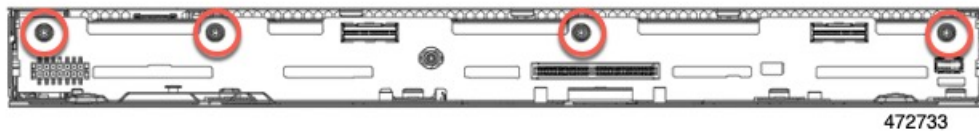

- b) Grasp the drive backplane and disconnect it from the module.

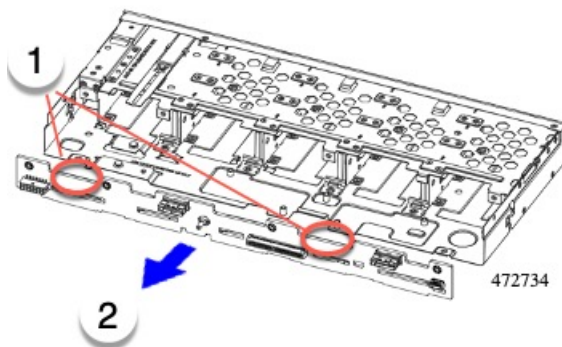
**Step 5**

Remove the PCBA and dispose of it properly in accordance with your local recycling and e-waste laws.

What to do next

Recycle the server front panel.

Recycling the Server Front Panel PCBA

The server's front panel contains one PCBA, which is horizontally mounted in a sheet metal tray. The front panel PCBA is attached to the tray's sheet metal by the following screws.

- Two size 2.5 slotted screws on the face of the tray.
- Two T10 Torx screws that secure the PCBA to the interior of the tray.

You must disconnect the PCBA from the tray before recycling the PCBA.

Before you begin

Note For Recyclers Only! This procedure is not a standard field-service option. This procedure is for recyclers who will be reclaiming the electronics for proper disposal to comply with local eco design and e-waste regulations.

To remove the printed circuit board assembly (PCBA), the following requirements must be met:

- The server must be disconnected from facility power.
- The server must be removed from the equipment rack.
- The server's top cover must be removed. See [Removing Top Cover](#).

Gather the following tools:

- A size 2.5 slotted screwdriver.
- A T10 Torx screwdriver.

Step 1 Remove the front panel from the front mezzanine module.

- a) Using a T10 Torx screwdriver, remove the screw that secures the front panel to the front mezzanine module.
- b) Grasp the front panel module and slide it out of the front mezzanine module.

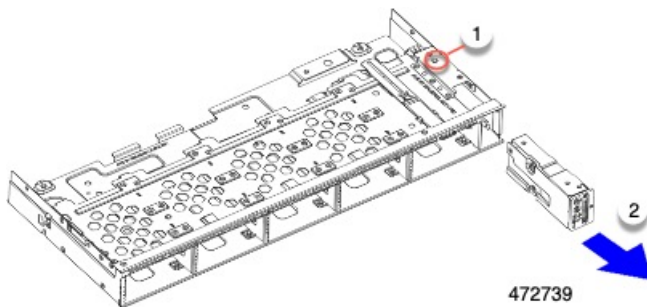

Step 2 Remove the front panel PCBA.

- a) Using a 2.5 slotted screwdriver, remove the two screws on the face of the front panel.

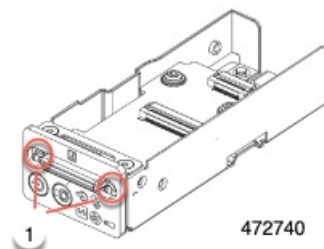

- b) Using a T10 screwdriver, remove the two screws that secure the PCBA to the sheet metal.

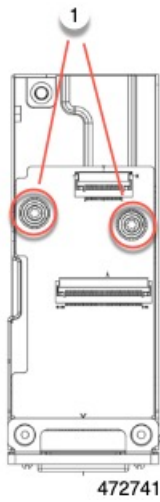

- c) Grasp the PCBA and simultaneously slide the PCBA upward to remove it.

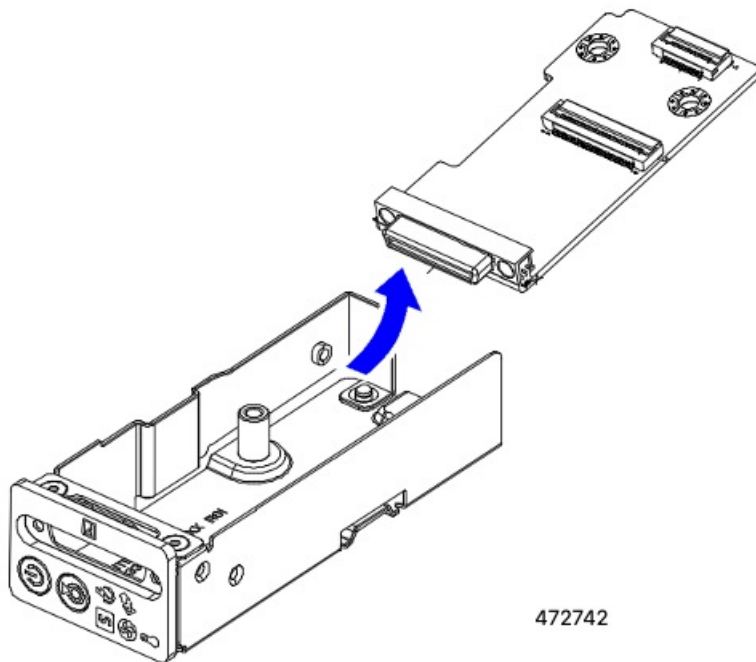

Step 3 Remove the PCBA and dispose of it properly in accordance with your local recycling and e-waste laws.
