



# CHAPTER 6

## Configuring the Switch Alarms

On the ME 3400E switch, you can configure external alarm inputs, as well as alarms to identify a missing or malfunctioning power supply or a power supply with no input.

- [Configuring External Alarms, page 6-1](#)
- [Configuring Power Supply Alarms, page 6-3](#)

### Configuring External Alarms

You can connect up to four alarm inputs from external devices in your environment, such as a door, a temperature gauge, or a fire alarm, to the alarm input port on the switch front panel. [Figure 6-1](#) shows the location of the alarm pinouts.

**Figure 6-1 Alarm Input Port Pinouts**

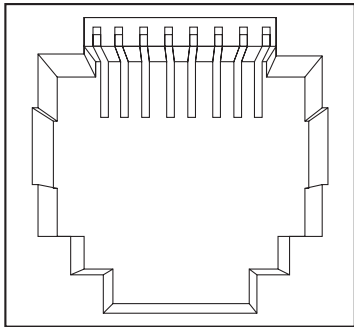
Pin	Alarm connection	1 2 3 4 5 6 7 8
1	Alarm 1 input	
2	Alarm 2 input	
3	no connection	
4	Alarm 3 input	
5	Alarm 4 input	
6	no connection	
7	no connection	
8	Alarm common	

For each alarm input, you can configure an open or closed circuit to trigger an alarm and configure the severity of the alarm. A triggered alarm generates a system message. If you enter a descriptive name for the alarm, that name is included in the system message. A triggered alarm also turns on the LED display (the LED is normally off, meaning no alarm). See the *Cisco ME-3400E Hardware Installation Guide* for information about the LEDs.

The alarm trigger setting is **open** or **closed**. If not set, the alarm is triggered when the circuit closes.

- Open means that the normal condition has current flowing through the contact (normally closed contact). The alarm is generated when the current stops flowing.
- Closed means that no current flows through the contact (normally open contact). The alarm is generated when current does flow.

You can set the alarm severity to **minor**, **major**, or **critical**. The severity is included in the alarm message and also sets the LED color when the alarm is triggered. The LED is amber for a minor alarm, red for a major alarm, and blinking red for a critical alarm. If not set, the default alarm severity is **minor**.

Beginning in privileged EXEC mode, follow these steps to configure alarm contacts.

	Command	Purpose
Step 1	<b>configure terminal</b>	Enter global configuration mode.
Step 2	<b>alarm-contact</b> <i>contact-number</i> <b>description</b> <i>string</i>	(Optional) Configure a description for the alarm contact number. <ul style="list-style-type: none"> <li>• The <i>contact-number</i> can be from 1 to 4.</li> <li>• The description string can be up to 80 alphanumeric characters in length and is included in any generated system messages.</li> </ul>
Step 3	<b>alarm-contact</b> { <i>contact-number</i>   <b>all</b> } { <b>severity</b> { <b>critical</b>   <b>major</b>   <b>minor</b> }   <b>trigger</b> { <b>closed</b>   <b>open</b> }	Configure the trigger and severity for an alarm contact number or for all contact numbers. <ul style="list-style-type: none"> <li>• Enter a contact number (1 to 4) or specify that you are configuring <b>all</b> alarms. See <a href="#">Figure 6-1</a> for the alarm contact pinouts.</li> <li>• For <b>severity</b>, enter <b>critical</b>, <b>major</b>, or <b>minor</b>. If you do not configure a severity, the default is <b>minor</b>.</li> <li>• For <b>trigger</b>, enter <b>open</b> or <b>closed</b>. If you do not configure a trigger, the alarm is triggered when the circuit is <b>closed</b>.</li> </ul>
Step 4	<b>end</b>	Return to privileged EXEC mode.
Step 5	<b>show env alarm-contact</b>	Show the configured alarm contacts.
Step 6	<b>copy running-config startup-config</b>	(Optional) Save your entries in the configuration file.

To delete the alarm description, enter the **no alarm-contact** *contact-number* **description** privileged EXEC command. To set the alarm severity to **minor** (the default), enter the **no alarm-contact** { *contact-number* | **all** } **severity**. To set the alarm contact trigger to **closed** (the default), enter the **no alarm-contact** { *contact-number* | **all** } **trigger**.

To see the alarm configuration and status, enter the **show env alarm-contact** privileged EXEC command.

For more detailed information about the alarm commands, see the command reference for this release.



**Note**

The switch supports the CISCO-ENTITY-ALARM-MIB for these alarms.

This example configures alarm input 2 named *door sensor* to assert a major alarm when the door circuit is closed and then displays the status and configuration for all alarms:

```
Switch(config)# alarm-contact 2 description door sensor
Switch(config)# alarm-contact 2 severity major
Switch(config)# alarm-contact 2 trigger closed
Switch(config)# end
Switch(config)# show env alarm-contact
Switch# show env alarm-contact
ALARM CONTACT 1
  Status:      not asserted
  Description: test_1
  Severity:    critical
  Trigger:     open
ALARM CONTACT 2
  Status:      not asserted
  Description: door sensor
  Severity:    major
  Trigger:     closed
ALARM CONTACT 3
  Status:      not asserted
  Description: flood sensor
  Severity:    critical
  Trigger:     closed
ALARM CONTACT 4
  Status:      not asserted
  Description:
  Severity:    critical
  Trigger:     closed
```

## Configuring Power Supply Alarms

Some switch models have two power supply slots that contain either AC- or DC- power supplies. The status and type of power supplied to each slot is shown by the switch LEDs. AC power supplies have corresponding AC-power inputs (AC 1 and AC 2), and DC-power supplies have two DC inputs (DC A and DC B).

The default power supply configuration is to have one power supply installed in slot 1 and the software configured for **no power-supply dual**. This suppresses any alarms triggered by not having two power supplies installed. When the switch is operating with two power supplies, we recommend you enter the **power-supply dual** global configuration command to trigger an alarm when one is missing or inoperable.

If you are using DC-power supplies, the most common practice is to have both DC inputs connected.



### Note

---

The Cisco ME 3400EG-2CS-A switch does not support removable power supplies.

---

When the switch detects a power supply fault, it triggers an LED indicator and sends a system message. Power-supply alarm indications are sent when a power supply is missing, has no input, has insufficient output, or has a malfunctioning fan. Some of these alarm conditions are configurable.

## Power-Supply-Missing Alarms

If you are operating the switch with a single power supply (AC or DC), you can suppress any alarm conditions associated with a missing power supply. Entering the **no power-supply dual** global configuration command (the default) specifies that only one power supply is expected to be present. Then the switch does not generate an alarm that a power supply is missing.

The **no power-supply dual** command controls only the sending of messages about the absence of a second power supply or the absence of input to the second power supply. The software detects whether a power supply is present and if there is an input voltage. When there is input, the software can detect if there is output voltage and if the fan is operating. These are possible conditions and results when only one power supply is expected:

- If only one power supply is present, no alarm is sent. However, if this power supply is connected to the AC input and is not receiving or sending power, a power supply fault message is sent.
- If two power supplies are present, and both are receiving and sending power, no message is sent.
- If two power supplies are present, and one is connected and operating and the other is not connected to the AC input, no message is sent.
- If two power supplies are present and both are connected to AC inputs, but only one is receiving or sending power, a power supply fault message is sent.



### Note

The switch always sends an error message when an AC-power supply connected to an AC input is not receiving or outputting power.

If you operate the switch with two power supplies, enter the **power-supply dual** global configuration command to configure the switch to send a message when one power supply is missing.

## DC-Power-Supply Feed Alarms

The two DC-power supply inputs are bridged internally and fed to both power supply slots. When one or two DC-power supplies are installed, if the switch does not detect both DC inputs, it generates an LED alarm and a system message. If you want to use only one DC input, you can enter the **no power-supply dual dc-feed** global configuration command to disable sending alarm messages when the second DC input is not present. This command is valid only when DC-power supplies are installed in the switch.

Regardless of how this command is configured, if the expected DC-power inputs (one or two) are present and a problem is detected in the power supply, a faulty power-supply message is generated.

Beginning in privileged EXEC mode, follow these steps to configure power supply alarm messages.

	Command	Purpose
Step 1	<b>configure terminal</b>	Enter global configuration mode.
Step 2	<b>[no] power-supply dual</b>	Specify if an alarm is generated when only one power supply is installed in the switch. <ul style="list-style-type: none"> <li>• Enter <b>no power-supply dual</b> to suppress alarm indications for a missing power supply. This is the default.</li> <li>• Enter <b>power-supply dual</b> to enable alarm indications for both power supplies.</li> </ul>

	Command	Purpose
Step 3	<b>[no] power-supply dual dc-feed</b>	Specify if an alarm is generated when only DC power supply is installed and only one DC power input is present. <ul style="list-style-type: none"> <li>• Enter <b>no power-supply dual dc-feed</b> to suppress alarm indications for a missing DC power supply input.</li> <li>• Enter <b>power-supply dual dc-feed</b> to enable alarm indications when a single DC power supply input is present. This is the default.</li> </ul>
Step 4	<b>end</b>	Return to privileged EXEC mode.
Step 5	<b>show env power</b>	Show the configured power supply alarm indications.
Step 6	<b>copy running-config startup-config</b>	(Optional) Save your entries in the configuration file.

You can verify switch power supply settings by entering the **show env power** user EXEC command.

For more information about the commands, see the command reference for this release.

This example shows how to suppress alarm indications when a single power supply is present and to verify the configuration:

```
Switch(config)# no power-supply dual
Switch(config)# end
Switch# show env power
POWER SUPPLY 1 is AC OK
  AC Input   : OK
  Output    : OK
  Fan       : OK
POWER SUPPLY 2 is NOT PRESENT
```

