



Configuring Precision Time Protocol

- [Information About Precision Time Protocol](#) , on page 1
- [Information About NTP to PTP Time Conversion](#), on page 12
- [Prerequisites](#), on page 17
- [Guidelines and Limitations](#), on page 18
- [Default Settings](#), on page 20
- [Configuring PTP on the Switch](#), on page 20
- [Configuring NTP to PTP Time Conversion](#), on page 31
- [Related Documents](#), on page 36
- [Feature History](#), on page 36

Information About Precision Time Protocol

Precision Time Protocol (PTP) is defined in IEEE 1588 as Precision Clock Synchronization for Networked Measurements and Control Systems, and was developed to synchronize the clocks in packet-based networks that include distributed device clocks of varying precision and stability. PTP is designed specifically for industrial, networked measurement and control systems, and is optimal for use in distributed systems because it requires minimal bandwidth and little processing overhead.

Why PTP?

Smart grid power automation applications such as peak-hour billing, virtual power generators, and outage monitoring and management, require extremely precise time accuracy and stability. Timing precision improves network monitoring accuracy and troubleshooting ability.

In addition to providing time accuracy and synchronization, the PTP message-based protocol can be implemented on packet-based networks, such as Ethernet networks. The benefits of using PTP in an Ethernet network include:

- Low cost and easy setup in existing Ethernet networks
- Limited bandwidth is required for PTP data packets

Ethernet Switches and Delays

In an Ethernet network, switches provide a full-duplex communication path between network devices. Switches send data packets to packet destinations using address information contained in the packets. When the switch attempts to send multiple packets simultaneously, some of the packets are buffered by the switch so that they are not lost before they are sent. When the buffer is full, the switch delays sending packets. This delay can cause device clocks on the network to lose synchronization with one another.

Additional delays can occur when packets entering a switch are stored in local memory while the switch searches the MAC address table to verify packet CRC fields. This process causes variations in packet forwarding time latency, and these variations can result in asymmetrical packet delay times.

Adding PTP to a network can compensate for these latency and delay problems by correctly adjusting device clocks so that they stay synchronized with one another. PTP enables network switches to function as PTP devices, including boundary clocks (BCs) and transparent clocks (TCs).



Note To learn more about PTP clock devices and their role in a PTP network, refer to [PTP Clocks, on page 6](#).

Message-Based Synchronization

To ensure clock synchronization, PTP requires an accurate measurement of the communication path delay between the time source (*master*) and the receiver (*slave*). PTP sends messages between the master and slave device to determine the delay measurement. Then, PTP measures the exact message transmit and receive times and uses these times to calculate the communication path delay. PTP then adjusts current time information contained in network data for the calculated delay, resulting in more accurate time information.

This delay measurement principle determines path delay between devices on the network, and the local clocks are adjusted for this delay using a series of messages sent between masters and slaves. The one-way delay time is calculated by averaging the path delay of the transmit and receive messages. This calculation assumes a symmetrical communication path; however, switched networks do not necessarily have symmetrical communication paths, due to the buffering process.

PTP provides a method, using transparent clocks, to measure and account for the delay in a time-interval field in network timing packets, making the switches temporarily transparent to the master and slave nodes on the network. An end-to-end transparent clock forwards all messages on the network in the same way that a switch does.



Note Cisco PTP supports multicast PTP messages only.

To read a detailed description of synchronization messages, refer to [PTP Event Message Sequences, on page 3](#). To learn more about how transparent clocks calculate network delays, refer to [Transparent Clock, on page 6](#).

The following figure shows a typical 1588 PTP network that includes grandmaster clocks, switches in boundary clock mode, and Intelligent Electronic Device (IEDs) such as a digital relays or protection devices. In this diagram, Master 1 is the grandmaster clock. If Master 1 becomes unavailable, the boundary clock slaves switch to Master 2 for synchronization.

Figure 1: PTP Network

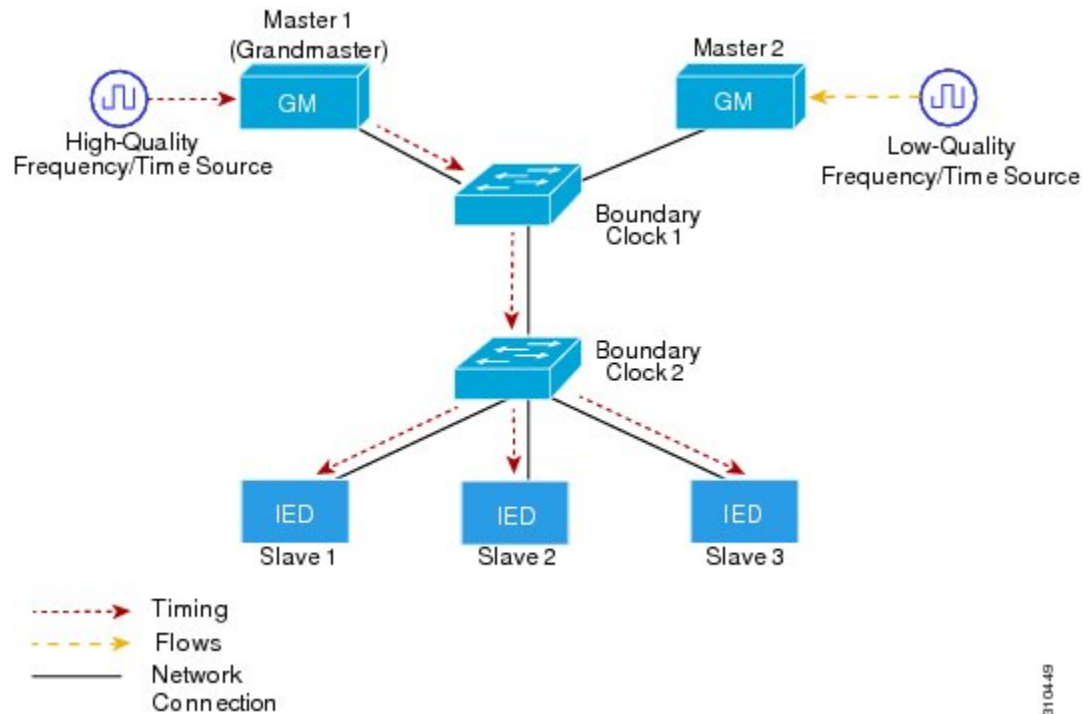

PTP Event Message Sequences

This section describes the PTP event message sequences that occur during synchronization.

Synchronizing with Boundary Clocks

The ordinary and boundary clocks configured for the delay request-response mechanism use the following event messages to generate and communicate timing information:

- Sync
- Delay_Req
- Follow_Up
- Delay_Resp

These messages are sent in the following sequence:

1. The master sends a Sync message to the slave and notes the time (t_1) at which it was sent.
2. The slave receives the Sync message and notes the time of reception (t_2).
3. The master conveys to the slave the timestamp t_1 by embedding the timestamp t_1 in a Follow_Up message.
4. The slave sends a Delay_Req message to the master and notes the time (t_3) at which it was sent.
5. The master receives the Delay_Req message and notes the time of reception (t_4).
6. The master conveys to the slave the timestamp t_4 by embedding it in a Delay_Resp message.

After this sequence, the slave possesses all four timestamps. These timestamps can be used to compute the offset of the slave clock relative to the master, and the mean propagation time of messages between the two clocks.

The offset calculation is based on the assumption that the time for the message to propagate from master to slave is the same as the time required from slave to master. This assumption is not always valid on an Ethernet network due to asymmetrical packet delay times.

Figure 2: Detailed Steps—Boundary Clock Synchronization

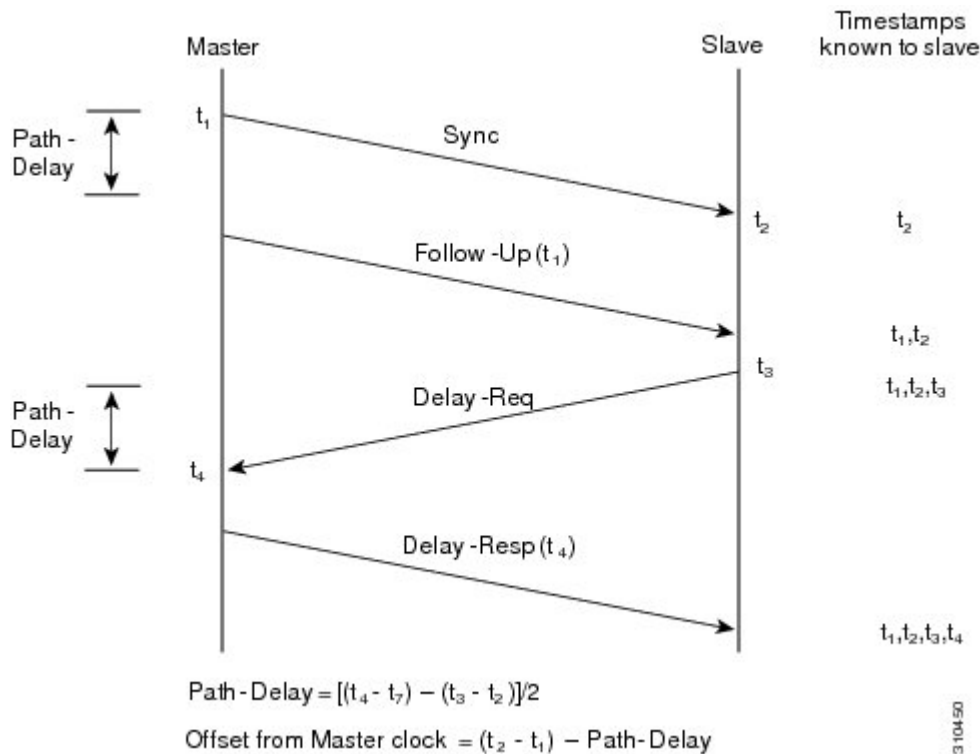

Synchronizing with Peer-to-Peer Transparent Clocks

When the network includes multiple levels of boundary clocks in the hierarchy, with non-PTP enabled devices between them, synchronization accuracy decreases.

The round-trip time is assumed to be equal to $\text{mean_path_delay}/2$, however this is not always valid for Ethernet networks. To improve accuracy, the resident time of each intermediary clock is added to the offset in the end-to-end transparent clock. Resident time, however, does not take into consideration the link delay between peers, which is handled by peer-to-peer transparent clocks.

Peer-to-peer transparent clocks measure the link delay between two clock ports implementing the peer delay mechanism. The link delay is used to correct timing information in Sync and Follow_Up messages.

Peer-to-peer transparent clocks use the following event messages:

- Pdelay_Req
- Pdelay_Resp
- Pdelay_Resp_Follow_Up

These messages are sent in the following sequence:

1. Port 1 generates timestamp t_1 for a Pdelay_Req message.
2. Port 2 receives and generates timestamp t_2 for this message.
3. Port 2 returns and generates timestamp t_3 for a Pdelay_Resp message.
To minimize errors due to any frequency offset between the two ports, Port 2 returns the Pdelay_Resp message as quickly as possible after the receipt of the Pdelay_Req message.
4. Port 2 returns timestamps t_2 and t_3 in the Pdelay_Resp and Pdelay_Resp_Follow_Up messages respectively.
5. Port 1 generates timestamp t_4 after receiving the Pdelay_Resp message. Port 1 then uses the four timestamps (t_1 , t_2 , t_3 , and t_4) to calculate the mean link delay.

Figure 3: Detailed Steps—Peer-to-Peer Transparent Clock Synchronization

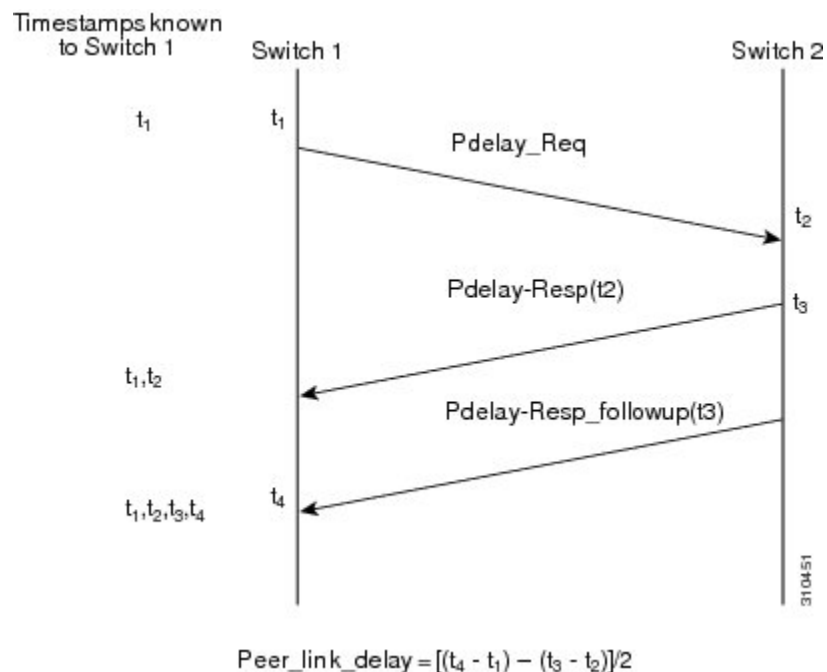

Synchronizing the Local Clock

In an ideal PTP network, the master and slave clock operate at the same frequency. However, *drift* can occur on the network. Drift is the frequency difference between the master and slave clock. You can compensate for drift by using the time stamp information in the device hardware and follow-up messages (intercepted by the switch) to adjust the frequency of the local clock to match the frequency of the master clock.

Best Master Clock Algorithm

The Best Master Clock Algorithm (BMCA) is the basis of PTP functionality. The BMCA specifies how each clock on the network determines the best master clock in its subdomain of all the clocks it can see, including itself. The BMCA runs on the network continuously and quickly adjusts for changes in network configuration.

The BMCA uses the following criteria to determine the best master clock in the subdomain:

- Clock quality (for example, GPS is considered the highest quality)
- Clock accuracy of the clock's time base
- Stability of the local oscillator
- Closest clock to the grandmaster

In addition to identifying the best master clock, the BMCA also ensures that clock conflicts do not occur on the PTP network by ensuring that:

- Clocks do not have to negotiate with one another
- There is no misconfiguration, such as two master clocks or no master clocks, as a result of the master clock identification process

PTP Clocks

A PTP network is made up of PTP-enabled devices and devices that are not using PTP. The PTP-enabled devices typically consist of the following clock types.

Grandmaster Clock

Within a PTP domain, the grandmaster clock is the primary source of time for clock synchronization using PTP. The grandmaster clock usually has a very precise time source, such as a GPS or atomic clock. When the network does not require any external time reference and only needs to be synchronized internally, the grandmaster clock can free run.

Ordinary Clock

An ordinary clock is a PTP clock with a single PTP port. It functions as a node in a PTP network and can be selected by the BMCA as a master or slave within a subdomain. Ordinary clocks are the most common clock type on a PTP network because they are used as end nodes on a network that is connected to devices requiring synchronization. Ordinary clocks have various interface to external devices.

Boundary Clock

A boundary clock in a PTP network operates in place of a standard network switch or router. Boundary clocks have more than one PTP port, and each port provides access to a separate PTP communication path. Boundary clocks provide an interface between PTP domains. They intercept and process all PTP messages, and pass all other network traffic. The boundary clock uses the BMCA to select the best clock seen by any port. The selected port is then set as a slave. The master port synchronizes the clocks connected downstream, while the slave port synchronizes with the upstream master clock.

Transparent Clock

The role of transparent clocks in a PTP network is to update the time-interval field that is part of the PTP event message. This update compensates for switch delay and has an accuracy of within one picosecond.

There are two types of transparent clocks:

End-to-end (E2E) transparent clocks measure the PTP event message transit time (also known as *resident time*) for SYNC and DELAY_REQUEST messages. This measured transit time is added to a data field (correction field) in the corresponding messages:

- The measured transit time of a SYNC message is added to the correction field of the corresponding SYNC or the FOLLOW_UP message.
- The measured transit time of a DELAY_REQUEST message is added to the correction field of the corresponding DELAY_RESPONSE message.

The slave uses this information when determining the offset between the slave's and the master's time. E2E transparent clocks do not provide correction for the propagation delay of the link itself.

Peer-to-peer (P2P) transparent clocks measure PTP event message transit time in the same way E2E transparent clocks do, as described above. In addition, P2P transparent clocks measure the upstream link delay. The upstream link delay is the estimated packet propagation delay between the upstream neighbor P2P transparent clock and the P2P transparent clock under consideration.

These two times (message transit time and upstream link delay time) are both added to the correction field of the PTP event message, and the correction field of the message received by the slave contains the sum of all link delays. In theory, this is the total end-to-end delay (from master to slave) of the SYNC packet.

The following figure illustrates PTP clocks in a master-slave hierarchy within a PTP network.

Figure 4: PTP Clock Hierarchy

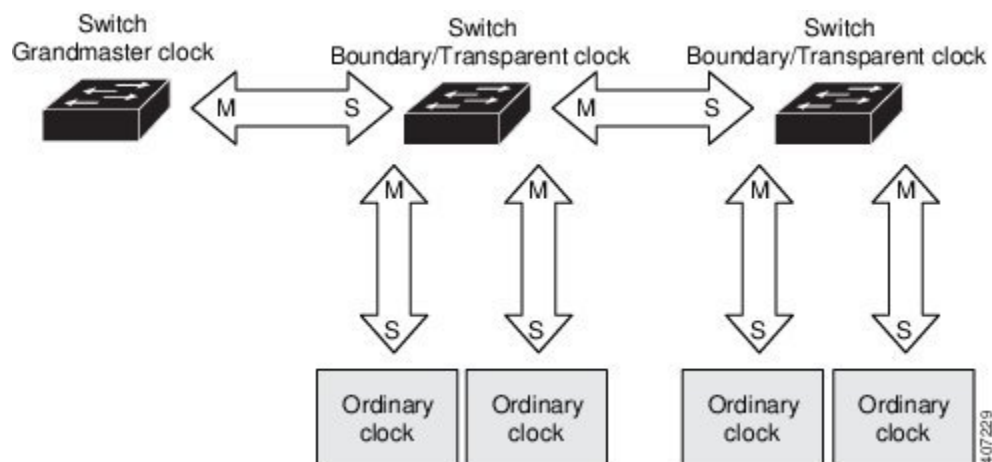

PTP Profiles

This section describes the following PTP profiles available on the switch:

- Power Profile
- Default Profile
- 802.1AS Profile (IE 4000 only)

The Power Profile is defined in PC37.238 - IEEE Draft Standard Profile for Use of IEEE 1588 Precision Time Protocol in Power System Applications. This switch documentation uses the terms Power Profile mode and Default Profile mode when referring to this IEEE 1588 profile and its associated configuration values.

The IEEE 1588 definition of a PTP profile is *the set of allowed PTP features applicable to a device*. A PTP profile is usually specific to a particular type of application or environment and defines the following values:

- Best master clock algorithm options

- Configuration management options
- Path delay mechanisms (peer delay or delay request-response)
- Range and default values of all PTP configurable attributes and data set members
- Transport mechanisms that are required, permitted, or prohibited
- Node types that are required, permitted, or prohibited
- Options that are required, permitted, or prohibited

Default Profile Mode

The default PTP profile mode on the switch is Default Profile mode. In this mode:

- The PTP mode of transport is Layer 3.
- The supported transparent clock mode is end-to-end (E2E).

[Table 1: Configuration Values for the IEEE PTP Power Profile and Switch Modes](#), on page 8 lists the configuration values for the switch in Default Profile mode.

Power Profile Mode

The IEEE Power Profile defines specific or allowed values for PTP networks used in power substations. The defined values include the optimum physical layer, the higher level protocol for PTP messages, and the preferred best master clock algorithm. The Power Profile values ensure consistent and reliable network time distribution within substations, between substations, and across wide geographic areas.

The switch is optimized for PTP in these ways:

- **Hardware**—The switch uses FPGA and PHY for the PTP function. The PHY time stamps the Fast Ethernet and Gigabit Ethernet ports.
- **Software**—In Power Profile mode, the switch uses the configuration values defined in the IEEE 1588 Power Profile standard.

The following table lists the configuration values defined by the IEEE 1588 Power Profile and the values that the switch uses for each PTP profile mode.

Table 1: Configuration Values for the IEEE PTP Power Profile and Switch Modes

PTP Field	Power Profile Value	Switch Configuration Value	
		Power Profile Mode	Default Profile Mode
Message transmission	Ethernet 802.3 with Ethertype 0X88F7. PTP messages are sent as 802.1Q tagged Ethernet frames with a default VLAN 0 and default priority 4.	Access Ports —Untagged Layer 2 packets. Trunk Ports —802.1Q tagged Layer 2 packets with native VLAN on the port and default priority value of 4.	Layer 3 packets. By default, 802.1q tagging is disabled.
MAC address —Non-peer delay messages	01-1B-19-00-00-00.	01-1B-19-00-00-00.	01-1B-19-00-00-00.

PTP Field	Power Profile Value	Switch Configuration Value	
		Power Profile Mode	Default Profile Mode
MAC address—Peer delay messages	01-80-C2-00-00-0E.	01-80-C2-00-00-0E.	Not applicable to this mode.
Domain number	0.	0.	0.
Path delay calculation	Peer-to-peer transparent clocks.	Peer-to-peer transparent clocks using the peer_delay mechanism.	End-to-end transparent clocks using the delay_request mechanism.
BMCA	Enabled.	Enabled.	Enabled.
Clock type	Two-step clocks are supported.	Two-step.	Two-step.
Time scale	Epoch. ¹	Epoch.	Epoch.
Grandmaster ID and local time determination	PTP-specific TLV (type, length, value) to indicate Grandmaster ID.	PTP-specific TLV to indicate Grandmaster ID.	PTP-specific type, length, and value to indicate Grandmaster ID.
Time accuracy over network hops	Over 16 hops, slave device synchronization accuracy is within 1 usec (1 microsecond).	Over 16 hops, slave device synchronization accuracy is within 1 usec (1 microsecond).	Not applicable in this mode.

¹ Epoch = Elapsed time since epoch start.

802.1AS Profile (IE 4000 only)



Note The 802.1AS Profile is supported for the IE 4000 only.

The IEEE 802.1AS standard "Timing and Synchronization for Time-Sensitive Applications in Bridged Local Area Networks" specifies the protocol and procedures used to ensure that synchronization requirements are met for time-sensitive applications across bridged and virtual bridged local area networks.

802.1AS specifies the use of IEEE 1588 (PTP) specifications where applicable in the context of IEEE Std 802.1D-2004 and IEEE Std 802.1Q-2005.1. The 802.1AS standard is one of three 802.1 AVB draft standards. 802.1AS over Ethernet (802.3) qualifies as a Profile of IEEE 1588-2008. It simplifies IEEE 1588 and defines synchronization over different types of media.

Key characteristics of 802.1AS are:

- For Ethernet full-duplex links, it uses the peer delay mechanism.
- All switches in the domain need to be 802.1AS capable.
- Transportation of 802.1AS packets is L2 multicast only, with no VLAN tag.
- It requires two-step processing (use of Follow_Up and Pdelay_Resp_Follow_Up messages to communicate timestamps).

- There is only a single active grandmaster in a time-aware network. That is, there is only a single 802.1AS domain.
- The BMCA (Best Master Clock Algorithm) is same as that used in IEEE 1588 with the following exceptions:
 - Announce messages received on a slave port that were not sent by the receiving time-aware system are used immediately; that is, there is no foreign-master qualification.
 - A port that the BMCA determines should be a master port enters the master state immediately; that is, there is no pre-master state.
 - The uncalibrated state is not needed and therefore not used.
 - All time-aware systems are required to participate in best master selection (even if the system is not grandmaster capable).

802.1AS on the IE 4000

On the IE 4000, 802.1AS is used in the Time Sensitive Network (TSN) feature. However, as a precise timing distribution mechanism, 802.1AS runs by itself without TSN configuration or inputs. The 802.1AS feature software implementation is based on the existing time stamping functionality of FPGA and has no new requirement on hardware beyond other PTP profiles.

The end-to-end time-synchronization performance of 802.1AS on the IE 4000 is as follows:

- Any two time-aware systems separated by six or fewer time-aware systems (that is, seven or fewer hops) will be synchronized to within 1 μ s peak-to-peak of each other during steady-state operation.
- Performance beyond 7 hops is not defined.

802.1AS Profile Comparison

Table 2: Comparison of PTP Profiles on IE Switches

Profile	Default (*)		Power		802.1AS
Standard	IEEE1588 v2 (J.3)		IEEE C37.238		IEEE802.1AS
Mode	Boundary	End-to-End transparent	Boundary	Peer-to-Peer transparent	**
Path Delay	Delay req/res	Delay req/res	Peer delay req/res	Peer delay req/res	Peer delay req/res
Non-PTP device allowed in PTP domain	Yes	Yes	No	No	No
Transport	UDP over IP (multicast and unicast)		L2 Multicast		L2 Multicast

* Delay Request-Response Default PTP profile (as defined in IEEE1588 J.3).

** There is no mode setting for 802.1AS. Mathematically it is equivalent to P2P transparent, but it works differently from a transparent clock.

Tagging Behavior for PTP Packets

The following table describes the switch tagging behavior in Power Profile and Default Profile modes.

Table 3: Tagging Behavior for PTP Packets

Switch Port Mode	Configuration	Power Profile Mode		Default Profile Mode	
		Behavior	Priority	Behavior	Priority
Trunk Port	vlan dot1q tag native enabled	Switch tags packets	7	Switch tags packets	7
Trunk Port	vlan dot1q tag native disabled	PTP software tags packets	4	Untagged	None
Access Port	N/A	Untagged	None	Untagged	None

PTP Clock Modes Supported on the Switch

PTP synchronization behavior depends on the PTP clock mode that you configure on the switch. You can configure the switch for one of the following global modes.

See [Guidelines and Limitations, on page 18](#) for guidelines for configuring each of the clock modes.

Boundary Clock Mode

A switch configured for boundary clock mode participates in selecting the best master clock on the subdomain, selecting from all clocks it can see, including itself. If the switch does not detect a more accurate clock than itself, then the switch becomes the master clock. If a more accurate clock is detected, then the switch synchronizes to that clock and becomes a slave clock.

After initial synchronization, the switch and the connected devices exchange PTP timing messages to correct the changes caused by clock offsets and network delays.

Forward Mode

A switch configured for forward mode passes incoming PTP packets as normal multicast traffic.

E2E Transparent Clock Mode

A switch configured for end-to-end transparent clock mode does not synchronize its clock with the master clock. A switch in this mode does not participate in master clock selection and uses the default PTP clock mode on all ports.

P2P Transparent Clock Mode

A switch configured for peer-to-peer transparent clock mode does not synchronize its clock with the master clock. A switch in this mode does not participate in master clock selection and uses the default PTP clock mode on all ports.

Configurable Boundary Clock Synchronization Algorithm

You can configure the BC synchronization algorithm to accommodate various PTP use cases, depending on whether you need to prioritize filtering of input time errors or faster convergence. A PTP algorithm that filters packet delay variation (PDV) converges more slowly than a PTP algorithm that does not.

By default, the BC uses a linear feedback controller (that is, a servo) to set the BC's time output to the next clock. The linear servo provides a small amount of PDV filtering and converges in an average amount of time. For improved convergence time, BCs can use the TC feedforward algorithm to measure the delay added by the network elements forwarding plane (the disturbance) and use that measured delay to control the time output.

While the feedforward BC dramatically speeds up the boundary clock, the feedforward BC does not filter any PDV. The adaptive PDV filter provides high quality time synchronization in the presence of PDV over wireless access points (APs) and enterprise switches that do not support PTP and that add significant PDV.

Three options are available for BC synchronization (all are compliant with IEEE 1588-2008):

- Feedforward—For very fast and accurate convergence; no PDV filtering.
- Adaptive—Filters as much PDV as possible, given a set of assumptions about the PDV characteristics, the hardware configuration, and the environmental conditions.



Note With the adaptive filter, the switch does not meet the time performance requirements specified in ITU-T G.8261.

- Linear—Provides simple linear filtering (the default).

Adaptive mode (**ptp transfer filter adaptive**) is not available in Power Profile mode.

For configuration information, see .

Information About NTP to PTP Time Conversion

NTP to PTP Time Conversion allows you to use Network Time Protocol (NTP) as a time source for PTP. Customers who use PTP for very precise synchronization within a site can use NTP across sites, where precise synchronization is not required.

NTP is the traditional method of synchronizing clocks across packet based networks. NTP uses a two-way time transfer mechanism, between a master and a slave. NTP is capable of synchronizing a device within a few 100 milliseconds across the Internet, and within a few milliseconds in a tightly controlled LAN. The ability to use NTP as a time source for PTP allows customers to correlate data generated in their PTP network with data in their enterprise data centers running NTP.

The following figure shows an example of an industrial network based on the Industrial Automation and Control System Reference Model. The enterprise zone and demilitarized zone run NTP, and the manufacturing

zone and cell/area zone run PTP with NTP as the time source. The switch with the NTP to PTP conversion feature can be either the Layer 2 Switch or the Distribution Switch in the Cell/Area Zone.

Figure 5: Industrial Network with NTP and PTP

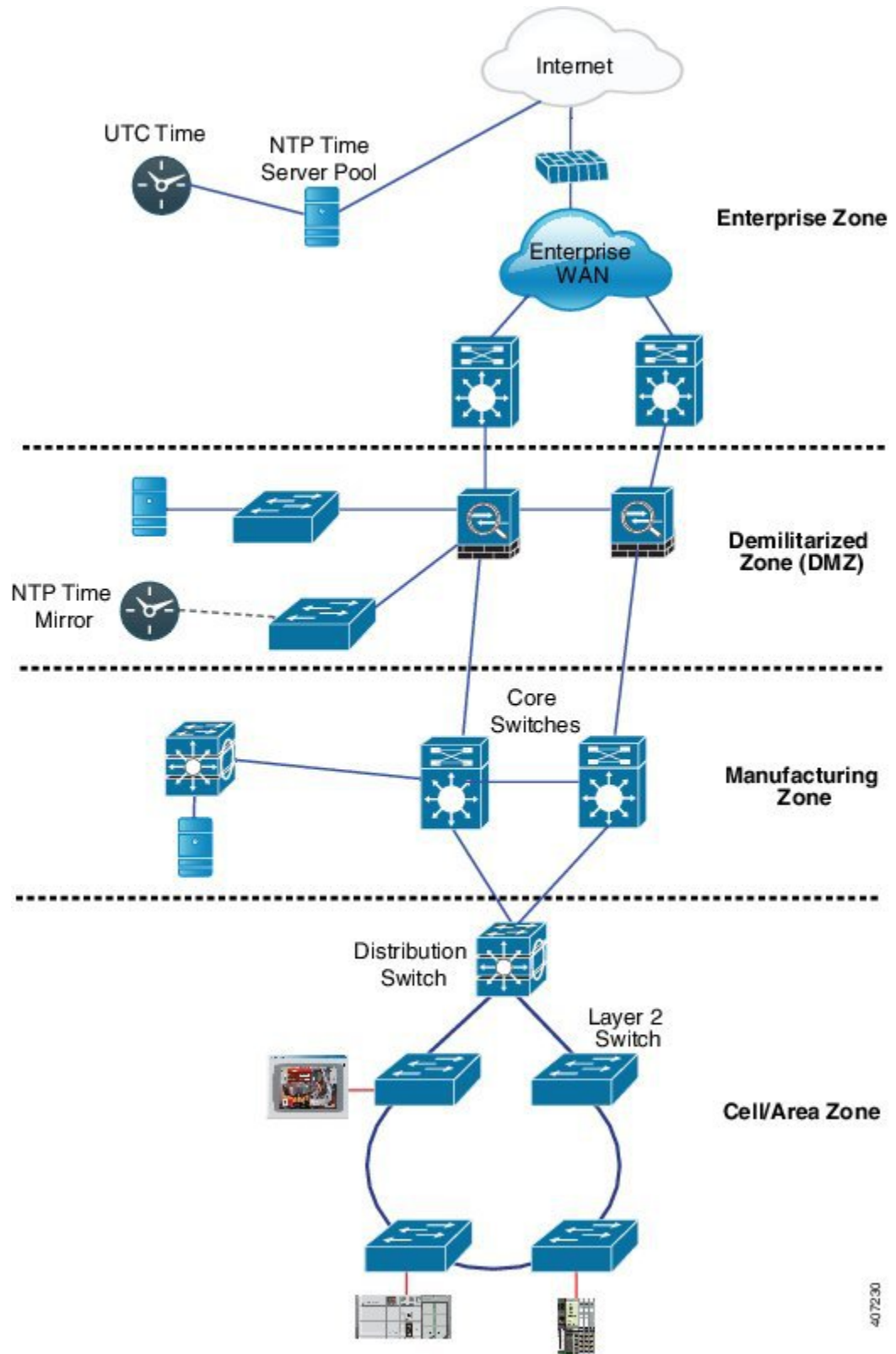

407230

Grandmaster Boundary Clock Hybrid

The NTP to PTP conversion feature adds grandmaster clock functionality to Cisco PTP, so the switch can be a time source as well as forward time. A new PTP clock type, grandmaster boundary clock (GMC-BC), provides the NTP time source for PTP. The GMC-BC acts like a BC, which is a multi-port device, with a single-port GMC connected to a virtual port on the BC. The GMC-BC switches between acting like a GMC when the GMC-BC is the primary GMC, and acting like a BC when the GMC-BC is a backup. This ensures that all devices on the PTP network remain synchronized in a failover scenario. The following figure shows a PTP network with redundant GMC-BCs. GMC-BC 1 is the grandmaster clock, and GMC-BC 2 is both backup GMC and BC.

Figure 6: Redundant GMC-BC Configuration

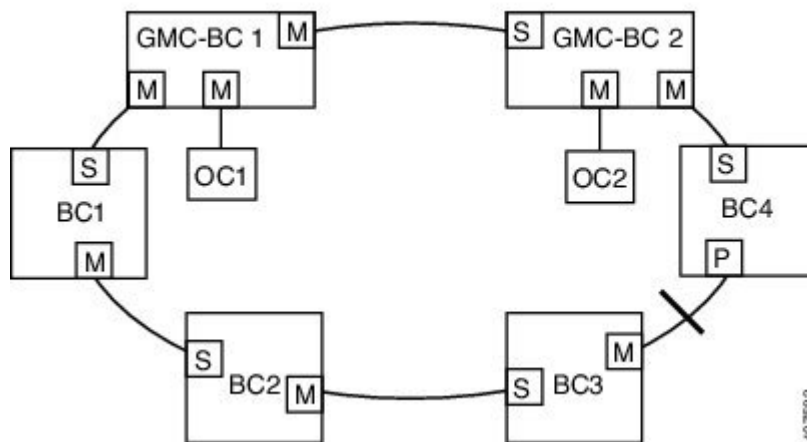

In a network with two GMC-BCs, the secondary GMC-BC can synchronize to both the NTP reference and the PTP reference at the same time, so the secondary GMC-BC can immediately take over when the primary GMC-BC fails. The GMC-BC instantly updates the time during a switchover.

Clock Manager

The clock manager is the component in the Cisco NTP to PTP software architecture that keeps track of the various time services and selects the clock that actively provides time. The clock manager notifies the time services of important changes, such as state changes, leap seconds, or daylight saving time.

The clock manager selects the NTP or manually-set clock first, followed by PTP and the real-time clock if NTP is not active. The following table shows the results of the clock selection process.

Table 4: Time Service Selection

NTP (Active) or Manually Set	PTP (Active)	Real-Time Clock	Selected Output
True	Don't care	Don't care	NTP or Manually Set
False	True	Don't care	PTP
False	False	True	Real-Time Clock

In general, the clock manager ensures that the time displayed in the Cisco IOS commands **show ptp clock** and **show clock** match. The **show clock** command always follows this priority, but there are two corner cases where the **show ptp clock** time may differ:

- The switch is either a TC or a BC, and there is no other active reference on the network. To preserve backwards compatibility, the TC and BC never take their time from the clock manager, only from the network's PTP GMC. If there is no active PTP GMC, then the time displayed in the **show clock** and the **show ptp clock** command output may differ.
- The switch is a synchronizing TC, a BC with a slave port, or a GMC-BC with slave port, and the time provided by the PTP GMC does not match the time provided by NTP or the user (that is, manually set). In this case, the PTP clock must forward the time from the PTP GMC. If the PTP clock does not follow the PTP GMC, then the PTP network will end up with two different time bases, which would break any control loops or sequence of event applications using PTP.

The following table shows how the Cisco IOS and PTP clocks behave given the various configurations. Most of the time, the two clocks match. Occasionally, the two clocks are different; those configurations are highlighted in the table.

Table 5: Expected Time Flow

IOS Clock Configuration	PTP Clock Configuration	IOS Clock Source	PTP Clock Source
Calendar	PTP BC, E2E TC, or GMC-BC in BC Mode	PTP	PTP
Manual	PTP BC, E2E TC, or GMC-BC in BC Mode	Manual	PTP
NTP	PTP BC, E2E TC, or GMC-BC in BC Mode	NTP	PTP
Calendar	GMC-BC in GM Mode	Calendar	Calendar
Manual	GMC-BC in GM Mode	Manual	Manual
NTP	GMC-BC in GM Mode	NTP	NTP

Prerequisites

- Review the [Guidelines and Limitations, on page 18](#).
- To use the NTP to PTP conversion feature, the switch must have an IP address for NTP to function.
- To use the NTP to PTP conversion feature, you must configure at least one NTP server. Configuring three or more NTP servers allows NTP to ignore bad clocks.



Note For information about configuring NTP, see the section [Configuring NTP](#) in the *Catalyst 3750-X and 3560-X Switch Software Configuration Guide, Release 12.2(55)SE*.

Guidelines and Limitations

PTP Messages

- The Cisco PTP implementation supports only the two-step clock and not the one-step clock. If the switch receives a one-step message from the Grand Master Clock, it will convert it into a two-step message.
- Cisco PTP supports multicast PTP messages only.

PTP Mode and Profile

- The switch and the grandmaster clock must be in the same PTP domain.
- When Power Profile mode is enabled, the switch drops the PTP announce messages that do not include these two Type, Length, Value (TLV) message extensions: *Organization_extension* and *Alternate_timescale*.

If the grandmaster clock is not compliant with PTP and sends announce messages without these TLVs, configure the switch to process the announce message by entering the **ptp allow-without-tlv** command.

- When the switch is in Power Profile mode, only the peer_delay mechanism is supported.

To change to [Boundary Clock Mode, on page 11](#) and the peer_delay mechanism, enter the **ptp mode boundary pdelay-req** command.

- To disable Power Profile mode and return the switch to [E2E Transparent Clock Mode, on page 11](#), enter the **no ptp profile power** command.
- In Default Profile mode, only the delay_request mechanism is supported.

To change to [Boundary Clock Mode, on page 11](#) with the delay_request mechanism, enter the **ptp mode boundary delay-req** command.

Packet Format

- The packet format for PTP messages can be 802.1q tagged packets or untagged packets.
- The switch does not support 802.1q QinQ tunneling.
- In switch Power Profile mode:
 - When the PTP interface is configured as an access port, PTP messages are sent as untagged, Layer 2 packets.
 - When the PTP interface is configured as a trunk port, PTP packets are sent as 802.1q tagged Layer 2 packets over the port native VLAN.
- Slave IEDs must support tagged and untagged packets.
- When PTP packets are sent on the native VLAN in [E2E Transparent Clock Mode, on page 11](#), they are sent as untagged packets. To configure the switch to send them as tagged packets, enter the global **vlan dot1q tag native** command.

VLAN Configuration

- Sets the PTP VLAN on a trunk port. The range is from 1 to 4094. The default is the native VLAN of the trunk port.
- In boundary mode, only PTP packets in PTP VLAN will be processed, PTP packets from other VLANs will be dropped.
- Before configuring the PTP VLAN on an interface, the PTP VLAN must be created and allowed on the trunk port.
- Most grandmaster clocks use the default VLAN 0. In Power Profile mode, the switch default VLAN is VLAN 1 and VLAN 0 is reserved. When you change the default grandmaster clock VLAN, it must be changed to a VLAN other than 0.
- When VLAN is disabled on the grandmaster clock, the PTP interface must be configured as an access port.

Clock Configuration

- All PHY PTP clocks are synchronized to the grandmaster clock. The switch system clock is not synchronized as part of PTP configuration and processes.
- When VLAN is enabled on the grandmaster clock, it must be in the same VLAN as the native VLAN of the PTP port on the switch.
- Grandmaster clocks can drop untagged PTP messages when a VLAN is configured on the grandmaster clock. To force the switch to send tagged packets to the grandmaster clock, enter the global **vlan dot1q tag native** command.

Clock Modes



Note The 802.1AS profile does not have a clock mode setting.

- Boundary Clock Mode
 - You can enable this mode when the switch is in [Power Profile Mode, on page 8](#) (Layer 2) or in [Default Profile Mode, on page 8](#) (Layer 3).
- Forward Mode
 - You can enable this mode when the switch is in [Power Profile Mode, on page 8](#) (Layer 2) or in [Default Profile Mode, on page 8](#) (Layer 3).
 - When the switch is in Forward mode, the only global configuration available is the CLI command to switch to a different PTP mode (that is, boundary, e2etransparent, or p2ptransparent).
- E2E Transparent Clock Mode
 - You can enable this mode only when the switch is in [Default Profile Mode, on page 8](#) (Layer 3).
 - When the switch is in E2E Transparent mode, the only global configuration available is the CLI command to switch to a different PTP mode (that is, boundary, p2ptransparent, or forward).

- P2P Transparent Clock Mode
 - You can enable this mode only when the switch is in [Power Profile Mode, on page 8](#) (Layer 2).
 - When the switch is in P2P Transparent mode, the only global configuration available is the CLI command to switch to a different PTP mode (that is, boundary, e2transparent, or forward).

PDV Filtering

Adaptive mode (**ptp transfer filter adaptive**) is not available in Power Profile mode.

PTP Interaction with Other Features

- The following PTP clock modes do not support EtherChannels:
 - e2transparent
 - p2pttransparent
 - boundary
- The following PTP clock modes only operate on a single VLAN:
 - e2transparent
 - p2pttransparent

Default Settings

- PTP is enabled on the switch by default.
- By default, the switch uses configuration values defined in the Default Profile (Default Profile mode is enabled).
- The switch default PTP clock mode is [E2E Transparent Clock Mode, on page 11](#).
- The default BC synchronization algorithm is linear filter.

Configuring PTP on the Switch

Use one of the following procedures in this section to configure the switch for PTP.



Note

To configure the switch for grandmaster-boundary clock mode (gmc-bc), see [Configuring NTP to PTP Time Conversion, on page 31](#).

Configuring PTP Power Profile Mode on the Switch

This section describes how to configure the switch to use the PTP Power Profile and operate in Power Profile mode.

Before you begin

These are some guidelines for configuring the Power Profile on the switch:

- When you enter **no** with PTP port configuration commands, the specified port property is set to the default value.
- To determine the value in seconds for the ptp global command *interval* variable, use a logarithmic scale. Below are examples of the *interval* variable value converted to seconds with a logarithmic scale:

Value Entered	Logarithmic Calculation	Value in Seconds
-1	2^{-1}	1/2
0	2^0	1

SUMMARY STEPS

1. Enter global configuration mode:
2. Set the Power Profile:
3. Specify the synchronization clock mode:
4. (Optional, BC and TC mode) Specify TLV settings:
5. (Optional, BC and TC mode) Specify the PTP clock domain:
6. (Optional, BC and TC mode) Specify the packet priority:
7. (Optional, BC mode only) Specify the BMCA priority:
8. (Optional, BC mode only) Specify time-property preservation:
9. (Optional, BC mode only) Specify the BC synchronization algorithm:
10. (Optional) Enter interface configuration mode:
11. (Optional) Specify port settings:
12. Return to privileged EXEC mode:
13. Verify your entries:
14. (Optional) Save your entries in the configuration file:

DETAILED STEPS

-
- Step 1** Enter global configuration mode:
configure terminal
- Step 2** Set the Power Profile:
ptp profile power
- Step 3** Specify the synchronization clock mode:

ptp mode {boundary pdelay-req | p2pttransparent | forward}

- **mode boundary pdelay-req**—Configures the switch for boundary clock mode using the delay-request mechanism. In this mode, the switch participates in the selection of the most accurate master clock. Use this mode when overload or heavy load conditions produce significant delay jitter.
- **mode p2pttransparent**—Configures the switch for peer-to-peer transparent clock mode and synchronizes all switch ports with the master clock. The link delay time between the participating PTP ports and the message transit time is added to the resident time. Use this mode to reduce jitter and error accumulation. This is the default in Power Profile mode.
- **mode forward**—Configures the switch to pass incoming PTP packets as normal multicast traffic.

Step 4 (Optional, BC and TC mode) Specify TLV settings:

ptp allow-without-tlv

Step 5 (Optional, BC and TC mode) Specify the PTP clock domain:

ptp domain *domain-number*

domain-number—A number from 0 to 255.

The participating grandmaster clock, switches, and slave devices should be in the same domain.

Step 6 (Optional, BC and TC mode) Specify the packet priority:

ptp packet *priority*

The PTP packets have a default priority of 4. Lower values take precedence.

Step 7 (Optional, BC mode only) Specify the BMCA priority:

ptp priority1 *priority* **priority2** *priority*

- **priority1** *priority*—Overrides the default criteria (such as clock quality and clock class) for the most accurate master clock selection.
- **priority2** *priority*—Breaks the tie between two switches that match the default criteria. For example, enter 2 to give a switch priority over identical switches. *priority*—A priority number from 0 to 255. The default is 128.

Step 8 (Optional, BC mode only) Specify time-property preservation:

ptp time-property persist {*value* | **infinite**}

- *value*—Time duration, in seconds, from 0-100000. The default is 300.
- **infinite**—Time properties are preserved indefinitely.

Preserving the time properties prevents slave clocks from detecting a variance in the time values when the redundant GMC comes out of standby.

Step 9 (Optional, BC mode only) Specify the BC synchronization algorithm:

ptp transfer {**feedforward** | **filter linear**}

- **feedforward**—Very fast and accurate. No PDV filtering.
- **filter linear**—Provides a simple linear filter (default).

Step 10 (Optional) Enter interface configuration mode:

```
interface interface-id
```

Step 11 (Optional) Specify port settings:

Boundary pdelay-req mode:

```
ptp {announce {interval value | timeout value} | pdelay-req interval value | enable | sync {interval value | limit value} | vlan value}
```

p2ptransparent mode:

```
ptp {pdelay-req interval value | enable | sync limit value | vlan value}
```

- **announce interval *value***—Sets the logarithmic mean interval in seconds to send announce messages. The range is 0 to 4. The default is 1 (2 seconds).
- **announce timeout *value***—Sets the logarithmic mean interval in seconds to announce timeout messages. The range is 2 to 10. The default is 3 (8 seconds).
- **pdelay-req interval *value***—Sets the logarithmic mean interval in seconds for slave devices to send pdelay request messages when the port is in the master clock state. The range is -3 to 5. The default is 0 (1 second).
- **enable**—Enables PTP on the port base module.
- **sync interval *value***—Sets the logarithmic mean interval in seconds to send synchronization messages. The range is -2 to 1. The default is 1 second.
- **sync limit *value***—Sets the maximum clock offset value before PTP attempts to resynchronize. The range is from 50 to 500000000 nanoseconds. The default is 10000 nanoseconds.
- **vlan *value***—Sets the PTP VLAN on a trunk port. The range is from 1 to 4094. The default is the native VLAN of the trunk port. In boundary mode, only PTP packets in PTP VLAN will be processed, PTP packets from other VLANs will be dropped. Before configuring the PTP VLAN on an interface, the PTP VLAN must be created and allowed on the trunk port.

Step 12 Return to privileged EXEC mode:

```
end
```

Step 13 Verify your entries:

```
show running-config
```

Step 14 (Optional) Save your entries in the configuration file:

```
copy running-config startup-config
```

Example

The following example configures the switch for P2P transparent mode (the default in Power Profile mode), specifies **allow-without-tlv** PTP message processing, and uses default values for all PTP interval settings:

```
switch(config)# ptp allow-without-tlv
```

The following example configures the switch for boundary clock mode using the peer delay request (pdelay-req) mechanism and uses default values for all PTP interval settings:

```
switch(config)# ptp mode boundary pdelay-req
```

Configuring Default Profile Mode on the Switch

This section describes how to configure the switch to operate in Default Profile mode.

Before you begin

The switch sends untagged PTP packets on the native VLAN when the switch port connected to the grandmaster clock is configured as follows:

- Switch is in Default Profile mode.
- Switch is in trunk mode.
- VLAN X is configured as the native VLAN.

When the grandmaster clock requires tagged packets, make one of the following configuration changes:

- Force the switch to send tagged frames by entering the global **vlan dot1q tag native** command.
- Configure the grandmaster clock to send and receive untagged packets. If you make this configuration change on the grandmaster clock, you can configure the switch port as an access port.

These are some guidelines for configuring the Default Profile on the switch:

- When you enter **no** with PTP port configuration commands, the specified port property is set to the default value.
- To determine the value in seconds for the ptp global command *interval* variable, use a logarithmic scale. Below are examples of the *interval* variable value converted to seconds with a logarithmic scale:

Value Entered	Logarithmic Calculation	Value in Seconds
-1	2^{-1}	1/2
0	2^0	1

SUMMARY STEPS

1. Enter global configuration mode:
2. Configure the switch for Default Profile mode when the switch is in Power Profile mode. If the switch is already in Default Profile mode, this command has no effect.
3. Specify the synchronization clock mode:
4. (Optional, BC and TC mode) Specify the PTP clock domain:
5. (Optional, BC mode only) Specify the BMCA priority:
6. (Optional, BC mode only) Specify time-property preservation:
7. (Optional, BC mode only) Specify the BC synchronization algorithm:

8. (Optional) Enter interface configuration mode:
9. (Optional) Specify port settings:
10. Return to privileged EXEC mode:
11. Verify your entries:
12. (Optional) Save your entries in the configuration file:

DETAILED STEPS

-
- Step 1** Enter global configuration mode:
- ```
configure terminal
```
- Step 2** Configure the switch for Default Profile mode when the switch is in Power Profile mode. If the switch is already in Default Profile mode, this command has no effect.
- ```
no ptp profile power
```
- Step 3** Specify the synchronization clock mode:
- ```
ptp {mode boundary delay-req | e2transparent | forward | gmc-bc}
```
- **mode boundary delay-req**—Configures the switch for boundary clock mode using the delay-request mechanism. In this mode, the switch participates in the selection of the most accurate master clock. Use this mode when overload or heavy load conditions produce significant delay jitter.
  - **mode e2transparent**—Configures the switch for end-to-end transparent clock mode. A switch clock in this mode synchronizes all switch ports with the master clock. This switch does not participate in master clock selection and uses the default PTP clock mode on all ports. This is the default clock mode. The message transit time is added to the resident time. Use this mode to reduce jitter and error accumulation.
  - **mode forward**—Configures the switch to pass incoming PTP packets as normal multicast traffic.
  - **mode gmc-bc**—Configures the switch for grandmaster-boundary clock mode. See [Configuring NTP to PTP Time Conversion, on page 31](#) to configure the switch for this mode.
- Step 4** (Optional, BC and TC mode) Specify the PTP clock domain:
- ```
ptp domain domain-number
```
- domain-number* —A number from 0 to 255.
- The participating grandmaster clock, switches, and slave devices should be in the same domain.
- Step 5** (Optional, BC mode only) Specify the BMCA priority:
- ```
ptp priority1 priority priority2 priority
```
- **priority1 priority**—Overrides the default criteria (such as clock quality and clock class) for the most accurate master clock selection.
  - **priority2 priority**—Breaks the tie between two switches that match the default criteria. For example, enter 2 to give a switch priority over identical switches.  
*priority* —A priority number from 0 to 255. The default is 128.
- Step 6** (Optional, BC mode only) Specify time-property preservation:
- ```
ptp time-property persist {value | infinite}
```

- *value*—Time duration, in seconds, from 0-100000. The default is 300.
- *infinite*—Time properties are preserved indefinitely.

Preserving the time properties prevents slave clocks from detecting a variance in the time values when the redundant GMC comes out of standby.

Step 7 (Optional, BC mode only) Specify the BC synchronization algorithm:

ptp transfer {**feedforward** | **filter** {**adaptive** | **linear**}}

- **feedforward**—Very fast and accurate. No PDV filtering.
- **filter adaptive**—Automatically filters as much PDV as possible.
- **filter linear**—Provides a simple linear filter (default).

Step 8 (Optional) Enter interface configuration mode:

interface *interface-id*

Step 9 (Optional) Specify port settings:

Boundary delay-req mode:

ptp {**announce** {**interval** *value* | **timeout** *value*} | **delay-req** **interval** *value* | **enable** | **sync** {**interval** *value* | **limit** *value*} | **vlan** *value*}

e2transparent mode:

ptp {**enable** | **sync** {**interval** *value* | **limit** *value*}}

- **announce interval** *value*—Sets the logarithmic mean interval in seconds to send announce messages. The range is 0 to 4. The default is 1 (2 seconds).
- **announce timeout** *value*— Sets the logarithmic mean interval in seconds to announce timeout messages. The range is 2 to 10. The default is 3 (8 seconds).
- **delay-req interval** *value*—Sets the logarithmic mean interval in seconds for slave devices to send delay request messages when the port is in the master clock state. The range is -2 to 6. The default is -5 (1 packet every 1/32 seconds, or 32 packets per second).
- **enable**—Enables PTP on the port base module.
- **sync interval** *value*—Sets the logarithmic mean interval in seconds to send synchronization messages. The range is -2 to 1. The default is 1 second.
- **sync limit** *value*—Sets the maximum clock offset value before PTP attempts to resynchronize. The range is from 50 to 500000000 nanoseconds. The default is 500000000 nanoseconds.
- **vlan** *value*—Sets the PTP VLAN on a trunk port. The range is from 1 to 4094. The default is the native VLAN of the trunk port. In boundary mode, only PTP packets in PTP VLAN will be processed, PTP packets from other VLANs will be dropped. Before configuring the PTP VLAN on an interface, the PTP VLAN must be created and allowed on the trunk port.

Step 10 Return to privileged EXEC mode:

end

- Step 11** Verify your entries:
show running-config
- Step 12** (Optional) Save your entries in the configuration file:
copy running-config startup-config
-

Example

The following example configures the switch to operate in Default Profile mode and end-to-end transparent mode, and uses default values for all PTP interval settings:

```
switch(config)# no ptp profile
switch(config)# ptp mode e2transparent
```

The following example configures the switch for Default Profile mode and boundary clock mode with the delay_request mechanism, and uses default values for all PTP interval settings:

```
switch(config)# no ptp profile
switch(config)# ptp mode boundary delay-req
```

Configuring 802.1AS Profile Mode on the Switch (IE 4000 only)

This section describes how to configure the IE 4000 switch to use the 802.1AS Profile and operate in 802.1AS Profile mode.

SUMMARY STEPS

1. Enter global configuration mode:
2. Set the 802.1AS Profile:

DETAILED STEPS

- Step 1** Enter global configuration mode:
configure terminal
- Step 2** Set the 802.1AS Profile:
ptp profile dot1as
-

Example

The following example shows configuring the IE 4000 switch to use the 802.1AS Profile:

```
IE4000-SW2(config)#ptp profile dot1as
```

802.1AS Troubleshooting

Refer to the following to troubleshoot 802.1AS issues:

- New Syslogs (Informational)—Parent and Grandmaster clock change syslogs notify user about the parent/grandmaster reselection. If that change happens frequently, or does not meet system expectation, further investigation should be taken. The following shows example log entries:
 - Mar 24 21:22:40.702: %PTP-6-PARENT_CLOCK_CHANGE: Old parent clock identity: 0x0:0:0:0:0:0:0 port number: 0, New parent clock identity: 0x0:35:1A:FF:FE:DA:12:80 port number: 9
 - Mar 24 21:22:40.702: %PTP-6-GRANDMASTER_CLOCK_CHANGE: Old grandmaster clock identity: 0x0:0:0:0:0:0:0, New grandmaster clock identity: 0x0:35:1A:FF:FE:DA:12:80
 - Mar 24 19:18:34.235: %PTP-6-GRANDMASTER_CLOCK_CHANGE_TO_LOCAL: Old grandmaster clock identity: 0x0:35:1A:FF:FE:DA:12:80, New grandmaster clock identity: 0x58:97:BD:FF:FE:D9:97:80 (local system)
- SyncReceive TimeOut
 - 802.1AS added a new timer to detect sync receive timeout. If the next sync message does not arrive within 3 x sync interval (specified in the header of first sync message) on a PTP SLAVE port, sync receive timeout occurs.
 - This can be learned by turning on **debug ptp event** and observing "PTP (Interface GigabitEthernet1/1): sync receipt timeout" on the console.
 - At SyncReceive Timeout, the state of that PTP port will no longer be SLAVE. The next BMCA will re-select the new SLAVE port.

Verifying Configuration

Command	Purpose
show ptp { clock foreign-master-records parent port { FastEthernet GigabitEthernet } time-property }	Specifies the PTP information to display. <ul style="list-style-type: none"> • clock—Displays PTP clock information. • foreign-master-records—Displays PTP foreign-master-records. • parent—Displays PTP parent properties. • port FastEthernet—Displays PTP properties for the FastEthernet IEEE 802.3 interfaces. • port GigabitEthernet—Displays PTP properties for the GigabitEthernet IEEE 802.3z interfaces. • time-property—Displays PTP clock-time properties.

Power Profile Example

```
switch# show ptp parent
PTP PARENT PROPERTIES
  Parent Clock:
    Parent Clock Identity: 0xA4:C:C3:FF:FE:BF:B4:0
    Parent Port Number: 23
    Observed Parent Offset (log variance): N/A
    Observed Parent Clock Phase Change Rate: N/A
  Grandmaster Clock:
    Grandmaster Clock Identity: 0xA4:C:C3:FF:FE:BF:2B:0
    Grandmaster Clock Quality:
      Class: 248
      Accuracy: Unknown
      Offset (log variance): N/A
      Priority1: 128
      Priority2: 128
switch# show ptp clock
PTP CLOCK INFO
  PTP Device Type: Boundary clock
  PTP Device Profile: Power Profile
  Clock Identity: 0xA4:C:C3:FF:FE:BF:E0:80
  Clock Domain: 0
  Number of PTP ports: 26
  PTP Packet priority: 4
  Priority1: 128
  Priority2: 128
  Clock Quality:
    Class: 248
    Accuracy: Unknown
    Offset (log variance): N/A
  Offset From Master(ns): 25
  Mean Path Delay(ns): 705
  Steps Removed: 4
  Local clock time: 14:23:56 PST Apr 5 2013
switch# show ptp foreign-master-record
PTP FOREIGN MASTER RECORDS
  Interface GigabitEthernet1/1
    Foreign master port identity: clock id: 0xF4:4E:5:FF:FE:E5:82:0
    Foreign master port identity: port num: 1
    Number of Announce messages: 4
    Message received port: 1
    Time stamps: 1999872004, 1999870997
  Interface GigabitEthernet1/2
    Empty
  Interface GigabitEthernet1/3
    Empty
  Interface GigabitEthernet1/4
    Empty
  Interface GigabitEthernet1/5
    Empty
  Interface GigabitEthernet1/6
    Empty
  Interface GigabitEthernet1/7
    Empty
  Interface GigabitEthernet1/8
    Empty
  Interface GigabitEthernet1/9
    Empty
  Interface GigabitEthernet1/10
    Empty
  Interface GigabitEthernet1/11
    Empty
```

```

Interface GigabitEthernet1/12
  Empty
Interface GigabitEthernet1/13
  Empty
Interface GigabitEthernet1/14
  Empty
Interface GigabitEthernet1/15
  Empty
Interface GigabitEthernet1/16
  Empty
Interface GigabitEthernet1/17
  Empty
Interface GigabitEthernet1/18
  Empty
Interface GigabitEthernet1/19
  Empty
Interface GigabitEthernet1/20
  Empty
switch#
switch# show ptp ?
  clock                show ptp clock information
  foreign-master-record show PTP foreign master records
  parent               show PTP parent properties
  port                 show PTP port properties
  time-property        show PTP clock time property
switch# show ptp time-property
PTP CLOCK TIME PROPERTY
  Current UTC offset valid: 0
  Current UTC offset: 35
  Leap 59: 0
  Leap 61: 0
  Time Traceable: 16
  Frequency Traceable: 32
  PTP Timescale: 1
  Time Source: Internal Osciliator
  Time Property Persistence: 300 seconds
switch# show ptp port GigabitEthernet 1/1
PTP PORT DATASET: GigabitEthernet1/1
  Port identity: clock identity: 0xF4:4E:5:FF:FE:E5:91:80
  Port identity: port number: 1
  PTP version: 2
  Port state: UNCALIBRATED
  Delay request interval(log mean): 5
  Announce receipt time out: 3
  Peer mean path delay(ns): 0
  Announce interval(log mean): 0
  Sync interval(log mean): 0
  Delay Mechanism: Peer to Peer
  Peer delay request interval(log mean): 0
  Sync fault limit: 500000000
switch#

```

802.1AS Profile Example

```

IE4000-SW2#show ptp clock //check profile, and clock offset
PTP CLOCK INFO PTP
Device Type: 802.1AS - Time Aware Bridge
PTP Device Profile: 802.1AS Profile
Clock Identity: 0x58:97:BD:FF:FE:D9:97:80
Clock Domain: 0
...
Offset From Master(ns): 3 // this should be less than 1uS
IE4000-SW2#show ptp port FastEthernet 1/9
PTP PORT DATASET: FastEthernet1/9

```

```

...
Neighbor Rate Ratio: 1 (+0 PPM) // this should be within +/-100PPM
Port 802.1AS capable: TRUE // 802.1AS capable

IE4000-SW2#show ptp parent
PTP PARENT PROPERTIES
...
Clock Identity Path Trace: // path trace TLV list - the clock IDs of nodes on the clock
distribution chain from the grandmaster
Clock Identity 0: 0x0:00:00:11:11:11:11:01 // grandmaster
Clock Identity 1: 0x0:35:1A:FF:FE:DA:12:80 // 2nd clock in the path

```

Configuration Example

The following example configures the switch for P2P transparent mode, specifies **allow-without-tlv** PTP message processing, and uses default values for all PTP interval settings:

```
switch(config)# ptp allow-without-tlv
```

The following example configures the switch for boundary clock mode using the peer delay request (pdelay-req) mechanism and uses default values for all PTP interval settings:

```
switch(config)# ptp mode boundary pdelay-req
```

The following example configures the switch to operate in Default Profile mode and end-to-end transparent mode and uses default values for all PTP interval settings:

```
switch(config)# no ptp profile
switch(config)# ptp mode e2transparent
```

The following example configures the switch for Default Profile mode and boundary clock mode with the delay_request mechanism, and uses default values for all PTP interval settings:

```
switch(config)# no ptp profile
switch(config)# ptp mode boundary delay-req
```

Configuring NTP to PTP Time Conversion

Before you begin

- Review the [Guidelines and Limitations, on page 18](#).
- To use the NTP to PTP conversion feature, the switch must have an IP address for NTP to function.
- To use the NTP to PTP conversion feature, you must configure at least one NTP server. Configuring three or more NTP servers allows NTP to ignore bad clocks.



Note For information about configuring NTP, see the section [Configuring NTP](#) in the *Catalyst 3750-X and 3560-X Switch Software Configuration Guide, Release 12.2(55)SE*.

- When you enter **no** with PTP port configuration commands, the specified port property is set to the default value.
- To determine the value in seconds for the `ptp` global command *interval* variable, use a logarithmic scale. Below are examples of the *interval* variable value converted to seconds with a logarithmic scale:

Value Entered	Logarithmic Calculation	Value in Seconds
-1	2^{-1}	1/2
0	2^0	1

SUMMARY STEPS

1. Enter global configuration mode:
2. Configure the switch for Default Profile mode when the switch is in Power Profile mode. If the switch is already in Default Profile mode, this command has no effect.
3. Specify GMC-BC as the synchronization clock:
4. (Optional) Specify the BMCA priority:
5. (Optional) Specify the BC synchronization algorithm:
6. Enter interface configuration mode:
7. (Optional) Specify port settings:
8. Return to privileged EXEC mode:
9. Verify your entries:
10. (Optional) Save your entries in the configuration file:

DETAILED STEPS

Step 1 Enter global configuration mode:

configure terminal

Step 2 Configure the switch for Default Profile mode when the switch is in Power Profile mode. If the switch is already in Default Profile mode, this command has no effect.

no ptp profile power

Step 3 Specify GMC-BC as the synchronization clock:

ptp mode gmc-bc delay-req

The GMC-BC automatically selects NTP as the time source if it is available.

Step 4 (Optional) Specify the BMCA priority:

`ptp priority1 priority priority2 priority`

- **priority1 *priority***—Overrides the default criteria (such as clock quality and clock class) for the most accurate master clock selection.
- **priority2 *priority***—Breaks the tie between two switches that match the default criteria. For example, enter 2 to give a switch priority over identical switches.*priority*—A priority number from 0 to 255. The default is 128.

Step 5 (Optional) Specify the BC synchronization algorithm:

```
ptp transfer {feedforward | filter {adaptive | linear}}
```

- **feedforward**—Very fast and accurate. No PDV filtering.
- **filter adaptive**—Automatically filters as much PDV as possible.
- **filter linear**—Provides a simple linear filter (default).

Step 6 Enter interface configuration mode:

```
interface interface-id
```

Step 7 (Optional) Specify port settings:

```
ptp {announce {interval value | timeout value} | delay-req interval value | enable | sync {interval value | limit value} | vlan value}
```

- **announce interval value**—Sets the logarithmic mean interval in seconds to send announce messages. The range is 0 to 4. The default is 1 (2 seconds).
- **announce timeout value**— Sets the time to announce timeout messages. The range is 2 to 10 seconds. The default is 3 (8 seconds).
- **delay-req interval value**—Sets the logarithmic mean interval in seconds for slave devices to send delay request messages when the port is in the master clock state. The range is -2 to 6. The default is -5 (1 packet every 1/32 seconds, or 32 packets per second).
- **enable**—Enables PTP on the port base module.
- **sync interval value**—Sets the logarithmic mean interval in seconds to send synchronization messages. The range is -2 to 1. The default is 1 second.
- **sync limit value**—Sets the maximum clock offset value before PTP attempts to resynchronize. The range is from 50 to 500000000 nanoseconds. The default is 500000000 nanoseconds.
- **vlan value**—Sets the PTP VLAN on a trunk port. The range is from 1 to 4094. The default is the native VLAN of the trunk port. In boundary mode, only PTP packets in PTP VLAN will be processed, PTP packets from other VLANs will be dropped. Before configuring the PTP VLAN on an interface, the PTP VLAN must be created and allowed on the trunk port.

Step 8 Return to privileged EXEC mode:

```
end
```

Step 9 Verify your entries:

```
show running-config
```

Step 10 (Optional) Save your entries in the configuration file:

```
copy running-config startup-config
```

Example

The following example configures the switch to use the Default Profile, act as Grandmaster Clock with NTP as the time source, and use the feedforward BC synchronization algorithm:

```
switch(config)# no ptp profile power
switch(config)# ptp mode gmc-bc
switch(config)# ptp transfer feedforward
```

Verifying Configuration

Perform these steps to verify that switch is running as GMC-BC, and that NTP and PTP are synchronized:

SUMMARY STEPS

1. Monitor the status of NTP until NTP locks:
2. Display the status of each individual NTP server:
3. After NTP is up and running, verify that the NTP clock and the PTP clock are in sync.

DETAILED STEPS

Step 1 Monitor the status of NTP until NTP locks:

show ntp status

Note especially the following fields:

- Clock is synchronized/unsynchronized.
- System poll interval—how often the NTP client sends messages in seconds.
- Last update—how many seconds since the last clock adjustment.

Example:

```
switch# show ntp status
Clock is synchronized, stratum 2, reference is 72.163.32.43
nominal freq is 286.1023 Hz, actual freq is 286.0738 Hz, precision is 2**21
ntp uptime is 58682700 (1/100 of seconds), resolution is 3496
reference time is D95162A8.68E52FF9 (22:52:24.409 UTC Wed Jul 15 2015)
clock offset is 0.0459 msec, root delay is 16.19 msec
root dispersion is 15.07 msec, peer dispersion is 0.10 msec
loopfilter state is 'CTRL' (Normal Controlled Loop), drift is 0.000099341 s/s
system poll interval is 1024, last update was 925 sec ago.
```

Step 2 Display the status of each individual NTP server:

show ntp association

- The sys.peer is the currently selected reference.
- Candidates are fallback references.
- Falsetickers are bad clocks that are ignored.

Note There is a delay of several seconds from NTP picking an association to NTP declaring lock.

Example:

```
switch# show ntp association
address      ref clock      st  when  poll reach  delay offset  disp
+~171.68.38.65 .GPS.          1   706  1024  377 60.318 -0.255 0.166
+~171.68.38.66 .GPS.          1   450  1024  377 60.333 -0.096 0.121
-~10.81.254.202 .GPS.          1   555  1024  377 48.707  2.804 0.111
x~173.38.201.115 .GPS.          1   322  1024  377 293.19 74.409 0.107
*~72.163.32.43 .GPS.          1    37  1024  375 17.110 -0.410 0.081
* sys.peer, # selected, + candidate, - outlyer, x falseticker, ~ configured
```

Step 3 After NTP is up and running, verify that the NTP clock and the PTP clock are in sync.

- **show clock detail** shows the NTP time.
- **show ptp clock** shows the PTP time and the BMCA dataset details.
- **show ptp clock** Steps Removed field indicates whether the GMC-BC really is the GMC or if some other clock is running the PTP network. When the GMC wins the BMCA, the Steps Removed field should be 0.

Example:

```
show clock detail
23:16:53.865 UTC Wed Jul 15 2015
Time source is NTP
show ptp clock
PTP CLOCK INFO

PTP Device Type: Grand Master clock - Boundary clock
PTP Device Profile: Default Profile
Clock Identity: 0xF4:4E:5:FF:FE:E5:95:0
Clock Domain: 0
Number of PTP ports: 20

Time Transfer: Linear Filter <<< Displayed when the clock is configured as a BC or a GMC-BC
Priority1: 128
Priority2: 128
Clock Quality:
  Class: 13
  Accuracy: Within 1s
  Offset (log variance): N/A
Offset From Master(ns): 0
Mean Path Delay(ns): 0

Steps Removed: 0
Local clock time: 23:16:53 UTC Jul 15 2015
```

Configuration Example

```
switch# conf t
switch(config)# no ptp profile power
switch(config)# ptp mode gmc-bc
switch(config)# ptp transfer feedforward
switch(config)# end
```

Related Documents

- [Cisco Industrial Ethernet 4000 switch product documentation](#)
- [Cisco Industrial Ethernet 5000 switch product documentation](#)
- [Converged Plantwide Ethernet \(CPwE\) Design and Implementation Guide](#)

Feature History

Feature Name	Release	Feature Information
802.1AS Profile	15.2(5)E2	Initial support on IE 4000 switches.
Time Service Enhancements	15.2(4)EA1	Initial support on IE 5000 switches for NTP to PTP Time Conversion, Feedforward BC, and PDV Filtering.
	15.2(4)EA	Initial support on IE 4000 switches for NTP to PTP Time Conversion, Feedforward BC, and PDV Filtering.
Precision Time Protocol	15.2(4)EC	Initial support of the feature on the IE 4010.
	15.2(2)EB1	Initial support of the feature on the IE 5000.
	15.2(2)EA	Initial support of the feature on the IE 4000.