



Configuring Seamless MPLS

- [Information about Seamless MPLS, on page 1](#)
- [How to configure Seamless MPLS, on page 2](#)
- [Configuration Examples for Seamless MPLS, on page 9](#)
- [Feature History for Seamless MPLS, on page 11](#)

Information about Seamless MPLS

The following sections provide information about Seamless MPLS.

Overview of Seamless MPLS

Seamless MPLS provides a highly flexible and scalable architecture to integrate multiple networks into a single MPLS domain. It is based on existing and well known protocols.

A large MPLS network can have several types of platforms and services in different parts of the network. Such a network would usually be divided into areas such as a core area and aggregation areas, and each of these areas have different Interior Gateway Protocols (IGPs). The IGP prefixes from one area cannot be distributed to another area. If the IGP prefixes cannot be distributed, then end-to-end Label-Switched-Paths (LSP) cannot be established. This affects the scalability of the network.

Seamless MPLS introduces greater scalability by establishing end-to-end LSPs. Seamless MPLS uses the Border Gateway Protocol (BGP) instead of IGP to forward the loopback prefixes of the Provider Edge (PE) routers. BGP distributes the prefixes end-to-end. This eliminates the need to install IGP prefixes of one domain in another domain.

Seamless MPLS introduces separation of the service and transport planes and provides end to end service independent transport. It removes the need for service specific configurations in network transport nodes.

Architecture for Seamless MPLS

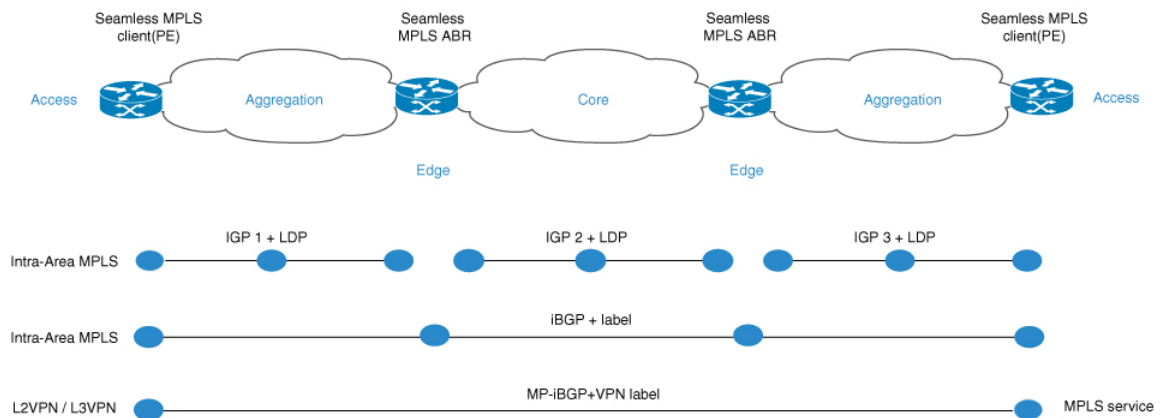

How to configure Seamless MPLS

The following sections provide information on how to configure Seamless MPLS.

Configuring Seamless MPLS on the PE Router

The following steps can be used to configure Seamless MPLS on the PE Router

SUMMARY STEPS

1. **enable**
2. **configure terminal**
3. **interface loopback slot/port**
4. **ip address ip-address subnet-mask**
5. **interface ethernet slot/port**
6. **no ip address**
7. **xconnect peer-ip-address vcid encapsulation mpls**
8. **router ospf process-id**
9. **network ip-address wild-mask area area-id**
10. **network ip-address wild-mask area area-id**
11. **router bgp autonomous-system-number**
12. **bgp log neighbor changes**
13. **address-family ipv4**
14. **network network-number mask network-mask**
15. **no bgp default ipv4 unicast**
16. **no bgp default route-target filter**
17. **neighbor ip-address remote-as autonomous-system-number**
18. **neighbor ip-address update-source interface-type interface-number**
19. **neighbor ip-address send-label**

DETAILED STEPS

	Command or Action	Purpose
Step 1	enable Example: Device> enable	Enables privileged EXEC mode. <ul style="list-style-type: none"> • Enter your password if prompted.
Step 2	configure terminal Example: Device# configure terminal	Enters global configuration mode.
Step 3	interface loopback slot/port Example: Device(config-if)# interface Loopback0	Configures a Loopback interface and enters interface configuration mode.
Step 4	ip address ip-address subnet-mask Example: Device(config-if) ip address 10.100.1.4 255.255.255.255	Enters the IP address for the interface.

	Command or Action	Purpose
Step 5	interface ethernet slot/port Example: Device(config-if)# interface Ethernet1/0	Configures an Ethernet interface and enters interface configuration mode.
Step 6	no ip address Example: Device(config-if)# no ip address	Removes an IP address definition.
Step 7	xconnect peer-ip-address vcid encapsulation mpls Example: Device(config-if)# xconnect 10.100.1.5 100 encapsulation mpls	Specifies MPLS as the tunneling method to encapsulate.
Step 8	router ospf process-id Example: Device(config)# router ospf 2	Configures the OSPF routing process.
Step 9	network ip-address wild-mask area area-id Example: Device(config-router)# network 10.2.0.0 0.0.255.255 area 0	Defines the interfaces on which OSPF runs and defines the area ID for those interfaces.
Step 10	network ip-address wild-mask area area-id Example: Device(config-router)# network 10.100.1.4 0.0.0.0 area 0	Defines the interfaces on which OSPF runs and defines the area ID for those interfaces.
Step 11	router bgp autonomous-system-number Example: Device(config)# router bgp 1	Configures the BGP routing process.
Step 12	bgp log neighbor changes Example: Device(config-router)# bgp log neighbor changes	Enables logging of BGP neighbor resets.
Step 13	address-family ipv4 Example: Device(config-router)# address-family ipv4	Enters address family configuration mode.
Step 14	network network-number mask network-mask Example: Device(config-router-af)# network 10.100.1.4 mask 255.255.255.255	Specifies the networks to be advertised by BGP and multiprotocol BGP routing processes.

	Command or Action	Purpose
Step 15	no bgp default ipv4 unicast Example: Device(config-router-af)# no bgp default ipv4 unicast	Disables default IPv4 unicast address family for peering session establishment
Step 16	no bgp default route-target filter Example: Device(config-router-af)# no bgp default route-target filter	Disables automatic BGP route-target community filtering.
Step 17	neighbor ip-address remote-as autonomous-system-number Example: Device(config-router-af)# neighbor 10.100.1.1 remote-as 1	Adds an entry to the BGP or multiprotocol BGP neighbor table.
Step 18	neighbor ip-address update-source interface-type interface-number Example: Device(config-router-af)# neighbor 10.100.1.1 update-source Loopback0	Allows BGP sessions to use any operational interface for TCP connections.
Step 19	neighbor ip-address send-label Example: Device(config-router-af)# neighbor 10.100.1.1 send-label	Enables a BGP router to send MPLS labels with BGP routes to a neighboring BGP router.

Configuring Seamless MPLS on the Route Reflector

The following steps can be used to configure Seamless MPLS on the Route Reflector.

SUMMARY STEPS

1. **enable**
2. **configure terminal**
3. **interface loopback slot/port**
4. **ip address ip-address subnet-mask**
5. **router ospf process-id**
6. **network ip-address wild-mask area area-id**
7. **network ip-address wild-mask area area-id**
8. **exit**
9. **router ospf process-id**
10. **redistribute ospf instance-tag route-map map-name**
11. **network ip-address wild-mask area area-id**
12. **exit**

13. **router bgp** *autonomous-system-number*
14. **bgp log neighbor changes**
15. **address-family ipv4**
16. **neighbor** *ip-address* **remote-as** *autonomous-system-number*
17. **neighbor** *ip-address* **update-source** *interface-type interface-number*
18. **neighbor** *ip-address* **next-hop-self all**
19. **neighbor** *ip-address* **send-label**
20. **neighbor** *ip-address* **remote-as** *autonomous-system-number*
21. **neighbor** *ip-address* **update-source** *interface-type interface-number*
22. **neighbor** *ip-address* **route-reflector-client**
23. **neighbor** *ip-address* **next-hop-self all**
24. **neighbor** *ip-address* **send-label**
25. **exit**
26. **ip prefix-list** *name seq number permit prefix*
27. **route-map** *name permit sequence-number*
28. **match ip address prefix-list** *prefix-list-name*

DETAILED STEPS

	Command or Action	Purpose
Step 1	enable Example: Device> enable	Enables privileged EXEC mode. <ul style="list-style-type: none"> • Enter your password if prompted.
Step 2	configure terminal Example: Device# configure terminal	Enters global configuration mode.
Step 3	interface loopback <i>slot/port</i> Example: Device(config-if)# interface Loopback0	Configures a Loopback interface and enters interface configuration mode.
Step 4	ip address <i>ip-address subnet-mask</i> Example: Device(config-if)# ip address 10.100.1.1 255.255.255.255	Enters the IP address for the interface.
Step 5	router ospf <i>process-id</i> Example: Device(config)# router ospf 1	Configures the OSPF routing process.
Step 6	network <i>ip-address wild-mask area area-id</i> Example:	Defines the interfaces on which OSPF runs and defines the area ID for those interfaces.

	Command or Action	Purpose
	Device(config-router)# network 10.1.0.0 0.0.255.255 area 0	
Step 7	network <i>ip-address wild-mask area area-id</i> Example: Device(config-router)# 10.100.1.1 0.0.0.0 area 0	Defines the interfaces on which OSPF runs and defines the area ID for those interfaces.
Step 8	exit Example: Device(config-router)#exit	Exits the configuration mode.
Step 9	router ospf <i>process-id</i> Example: Device(config)# router ospf 2	Configures the OSPF routing process.
Step 10	redistribute ospf <i>instance-tag route-map map-name</i> Example: Device(config-router)# redistribute ospf 1 subnets match internal route-map ospf1-into-ospf2	Injects routes from one routing domain into OSPF.
Step 11	network <i>ip-address wild-mask area area-id</i> Example: Device(config-router)# network 10.2.0.0 0.0.255.255 area 0	Defines the interfaces on which OSPF runs and defines the area ID for those interfaces.
Step 12	exit Example: Device(config-router)#exit	Exits the configuration mode.
Step 13	router bgp <i>autonomous-system-number</i> Example: Device(config)# router bgp 1	Configures the BGP routing process.
Step 14	bgp log neighbor changes Example: Device(config-router)# bgp log neighbor changes	Enables logging of BGP neighbor resets.
Step 15	address-family ipv4 Example: Device(config-router)# address family ipv4	Enters address family configuration mode.
Step 16	neighbor <i>ip-address remote-as autonomous-system-number</i> Example: Device(config-route-af)# neighbor 10.100.1.2 remote-as 1	Adds an entry to the BGP or multiprotocol BGP neighbor table.

	Command or Action	Purpose
Step 17	neighbor ip-address update-source interface-type interface-number Example: Device(config-router-af)# neighbor 10.100.1.2 update-source Loopback0	Allows BGP sessions to use any operational interface for TCP connections.
Step 18	neighbor ip-address next-hop-self all Example: Device(config-router-af)# neighbor 10.100.1.2 next-hop-self all	Configures a router as the next hop for a BGP-speaking neighbor or peer group.
Step 19	neighbor ip-address send-label Example: Device(config-router-af)# neighbor 10.100.1.2 send-label	Enables a BGP router to send MPLS labels with BGP routes to a neighboring BGP router.
Step 20	neighbor ip-address remote-as autonomous-system-number Example: Device(config-router-af)# neighbor 10.100.1.4 remote-as 1	Adds an entry to the BGP or multiprotocol BGP neighbor table.
Step 21	neighbor ip-address update-source interface-type interface-number Example: Device(config-router-af)# neighbor 10.100.1.4 update-source Loopback0	Allows BGP sessions to use any operational interface for TCP connections.
Step 22	neighbor ip-address route-reflector-client Example: Device(config_router-af)# neighbor 10.100.1.4 route-reflector-client	Configures the router as a BGP route reflector and configure the specified neighbor as its client.
Step 23	neighbor ip-address next-hop-self all Example: Device(config-router-af)# neighbor 10.100.1.4 next-hop-self all	Configures a router as the next hop for a BGP-speaking neighbor or peer group.
Step 24	neighbor ip-address send-label Example: Device(config-router-af)# neighbor 10.100.1.4 send-label	Enables a BGP router to send MPLS labels with BGP routes to a neighboring BGP router.
Step 25	exit Example: Device(config-router)#exit	Exits the configuration mode.

	Command or Action	Purpose
Step 26	ip prefix-list name seq number permit prefix Example: Device(config)# ip prefix-list prefix-list-ospf1-into-ospf2 seq 5 permit 10.100.1.1/32	Creates a prefix list to match IP packets or routes against.
Step 27	route-map name permit sequence-number Example: Device(config)# route-map ospf1-into-ospf2 permit 10	Creates the route map entry. Enters route-map configuration mode.
Step 28	match ip address prefix-list prefix-list-name Example: Device(config-route-map)# match ip address prefix-list prefix-list-ospf1-into-ospf2	Distributes routes that have a destination IP network number address that is permitted by a prefix list.

Configuration Examples for Seamless MPLS

The following sections provide examples for configuring Seamless MPLS.

Example: Configuring Seamless MPLS on PE Router 1

The following example shows how to configure Seamless MPLS on PE router 1.

```

Device(config-if)#interface Loopback0
 Device(config-if)#ip address 10.100.1.4 255.255.255.255
 !
Device(config-if)# interface Ethernet1/0
Device(config-if)# no ip address
Device(config-if)# xconnect 10.100.1.5 100 encapsulation mpls
 !
Device(config)# router ospf 2
Device(config-router)# network 10.2.0.0 0.0.255.255 area 0
Device(config-router)# network 10.100.1.4 0.0.0.0 area 0
 !
Device(config)#router bgp 1
Device(config-router)# bgp log-neighbor-changes
Device(config-router)# address family ipv4
Device(config-router-af)# network 10.100.1.4 mask 255.255.255.255
Device(config-router-af)# no bgp default ipv4 unicast
Device(config-router-af)# no bgp default route-target filter
Device(config-router-af)# neighbor 10.100.1.1 remote-as 1
Device(config-router-af)# neighbor 10.100.1.1 update-source Loopback0
Device(config-router-af)# neighbor 10.100.1.1 send-label

```

Example: Configuring Seamless MPLS on Route Reflector 1

The following examples shows how to configure Seamless MPLS on route reflector 1.

```

Device(cofig-if)# interface Loopback0
Device(cofig-if)# ip address 10.100.1.1 255.255.255.255

```

```

Device(config)# router ospf 1
Device(config-router)# network 10.1.0.0 0.0.255.255 area 0
Device(config-router)# network 10.100.1.1 0.0.0.0 area 0
!
Device(config)# router ospf 2
Device(config-router)# redistribute ospf 1 subnets match internal route-map ospf1-into-ospf2
Device(config-router)# network 10.2.0.0 0.0.255.255 area 0
!
Device(config)# router bgp 1
Device(config-router)# bgp log-neighbor-changes
Device(config-router)# address family ipv4
Device(config-router-af)# neighbor 10.100.1.2 remote-as 1
Device(config-router-af)# neighbor 10.100.1.2 update-source Loopback0
Device(config-router-af)# neighbor 10.100.1.2 next-hop-self all
Device(config-router-af)# neighbor 10.100.1.2 send-label
Device(config-router-af)# neighbor 10.100.1.4 remote-as 1
Device(config-router-af)# neighbor 10.100.1.4 update-source Loopback0
Device(config-router-af)# neighbor 10.100.1.4 route-reflector-client
Device(config-router-af)# neighbor 10.100.1.4 next-hop-self all
Device(config-router-af)# neighbor 10.100.1.4 send-label

Device(config)# ip prefix-list prefix-list-ospf1-into-ospf2 seq 5 permit 10.100.1.1/32

Device(config)# route-map ospf1-into-ospf2 permit 10
Device(config-route-map)# match ip address prefix-list prefix-list-ospf1-into-ospf2

```

Example: Configuring Seamless MPLS on PE Router 2

The following example shows how to configure Seamless MPLS on PE router 2.

```

Device(config-if)#interface Loopback0
Device(config-if)#ip address 10.100.1.5 255.255.255.255
!
Device(config-if)# interface Ethernet1/0
Device(config-if)# no ip address
Device(config-if)# xconnect 10.100.1.4 100 encapsulation mpls
!
Device(config)# router ospf 3
Device(config-router)# network 10.3.0.0 0.0.255.255 area 0
Device(config-router)# network 10.100.1.5 0.0.0.0 area 0
!
Device(config)#router bgp 1
Device(config-router)# bgp log-neighbor-changes
Device(config-router)# address family ipv4
Device(config-router-af)# network 10.100.1.5 mask 255.255.255.255
Device(config-router-af)# no bgp default ipv4 unicast
Device(config-router-af)# no bgp default route-target filter
Device(config-router-af)# neighbor 10.100.1.2 remote-as 1
Device(config-router-af)# neighbor 10.100.1.2 update-source Loopback0
Device(config-router-af)# neighbor 10.100.1.2 send-label

```

Example: Configuring Seamless MPLS on Route Reflector 2

The following examples shows how to configure Seamless MPLS on route reflector 2.

```

Device(cofig-if)# interface Loopback0
Device(cofig-if)# ip address 10.100.1.2 255.255.255.255
Device(config)# router ospf 1
Device(config-router)# network 10.1.0.0 0.0.255.255 area 0
Device(config-router)# network 10.100.1.2 0.0.0.0 area 0
!

```

```

Device(config)# router ospf 3
Device(config-router)# redistribute ospf 1 subnets match internal route-map ospf1-into-ospf3
Device(config-router)# network 10.3.0.0 0.0.255.255 area 0
!
Device(config)# router bgp 1
Device(config-router)# bgp log-neighbor-changes
Device(config-router)# address family ipv4
Device(config-router-af)# neighbor 10.100.1.1 remote-as 1
Device(config-router-af)# neighbor 10.100.1.1 update-source Loopback0
Device(config-router-af)# neighbor 10.100.1.1 next-hop-self all
Device(config-router-af)# neighbor 10.100.1.1 send-label
Device(config-router-af)# neighbor 10.100.1.5 remote-as 1
Device(config-router-af)# neighbor 10.100.1.5 update-source Loopback0
Device(config-router-af)# neighbor 10.100.1.5 route-reflector-client
Device(config-router-af)# neighbor 10.100.1.5 next-hop-self all
Device(config-router-af)# neighbor 10.100.1.5 send-label

Device(config)# ip prefix-list prefix-list-ospf1-into-ospf3 seq 5 permit 10.100.1.1/32

Device(config)# route-map ospf1-into-ospf3 permit 10
Device(config-route-map)# match ip address prefix-list prefix-list-ospf1-into-ospf3

```

Feature History for Seamless MPLS

This table provides release and related information for features explained in this module.

These features are available on all releases subsequent to the one they were introduced in, unless noted otherwise.

Release	Feature	Feature Information
Cisco IOS XE Gibraltar 16.12.1	Seamless MPLS	Seamless MPLS provides a highly flexible and scalable architecture to integrate multiple networks into a single MPLS domain. It is based on existing and well known protocols.

Use Cisco Feature Navigator to find information about platform and software image support. To access Cisco Feature Navigator, go to <http://www.cisco.com/go/cfn>.

