



## Installing Field Replaceable Units

- [Installing a Power Supply](#) , on page 1
- [Installing a Fan Module](#), on page 20
- [Installing an SSD Module](#), on page 27

### Installing a Power Supply

#### Power Supply Overview

The switch chassis has two slots in which you can install power supplies using any of the following combinations:

- Two AC, two DC or AC-DC power supplies
- One AC-input power supply or one DC-input power supply (leaving the blank cover on the other slot)



**Note** If you leave any power supply slots empty, you must ensure that the blank cover (Part Numbers PWR-C4-BLANK, C9K-PWR-C4-BLANK, C9K-PWR-C5-BLANK and PWR-C6-BLANK) is installed in that slot to maintain the designed airflow.

This table lists the power supply models. To understand about the power supply modules supported on different switch models, see [Power Supply Slots](#).

Part Number	Description
C9K-PWR-650WAC-R	650W AC Power Supply
C9K-PWR-650WACL-R	650W AC Power Supply
PWR-C4-950WAC-R	950W AC Power Supply
C9K-PWR-1600WAC-R	1600W AC Power Supply
C9K-PWR-930WDC-R	930W DC Power Supply
C9-PWR-950WDC-R	950W DC Power Supply

Part Number	Description
C9K-PWR-1600WDC-R	1600W DC Power Supply

Figure 1: Cisco Catalyst 650W AC Input Power Supply (C9K-PWR-650WAC-R)

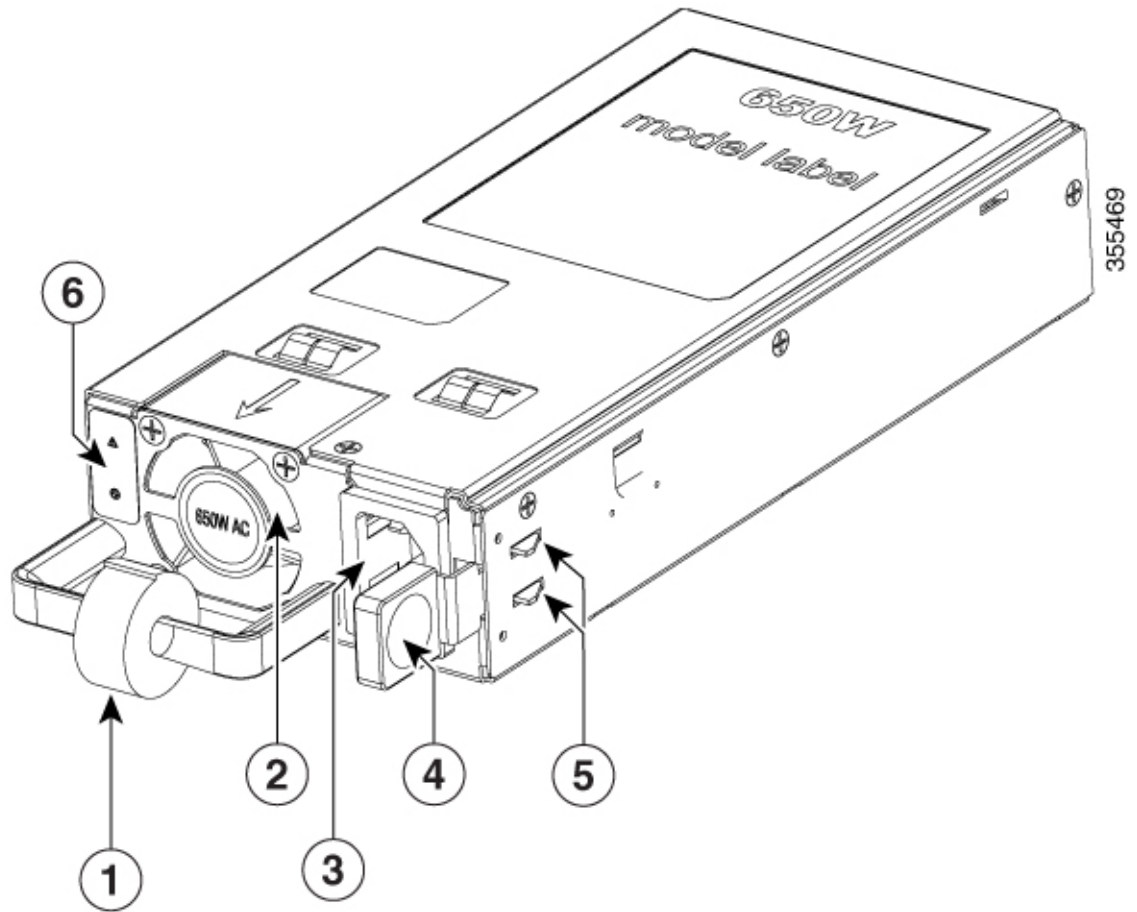

1	Velcro strap	4	Release latch
2	PSU fan	5	Retainer clips
3	AC power cord connector	6	Power status and power supply failure LEDs

Figure 2: Cisco Catalyst 650W AC Input Power Supply (C9K-PWR-650WACL-R)

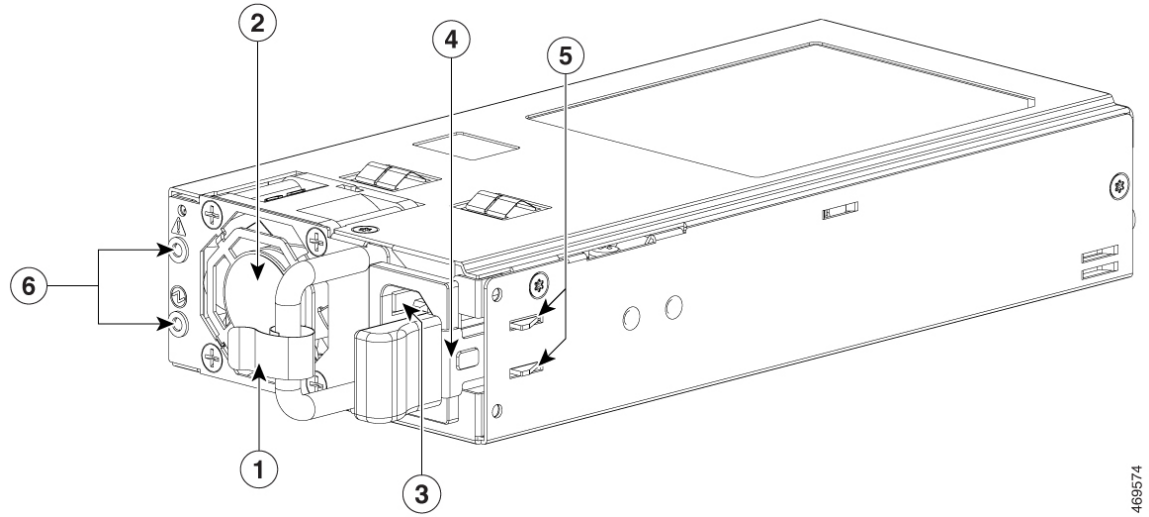

469574

1	Velcro strap	4	Release latch
2	PSU fan	5	Retainer clips
3	AC power cord connector	6	Power status and power supply failure LEDs

Figure 3: Cisco Catalyst 950W AC Input Power Supply

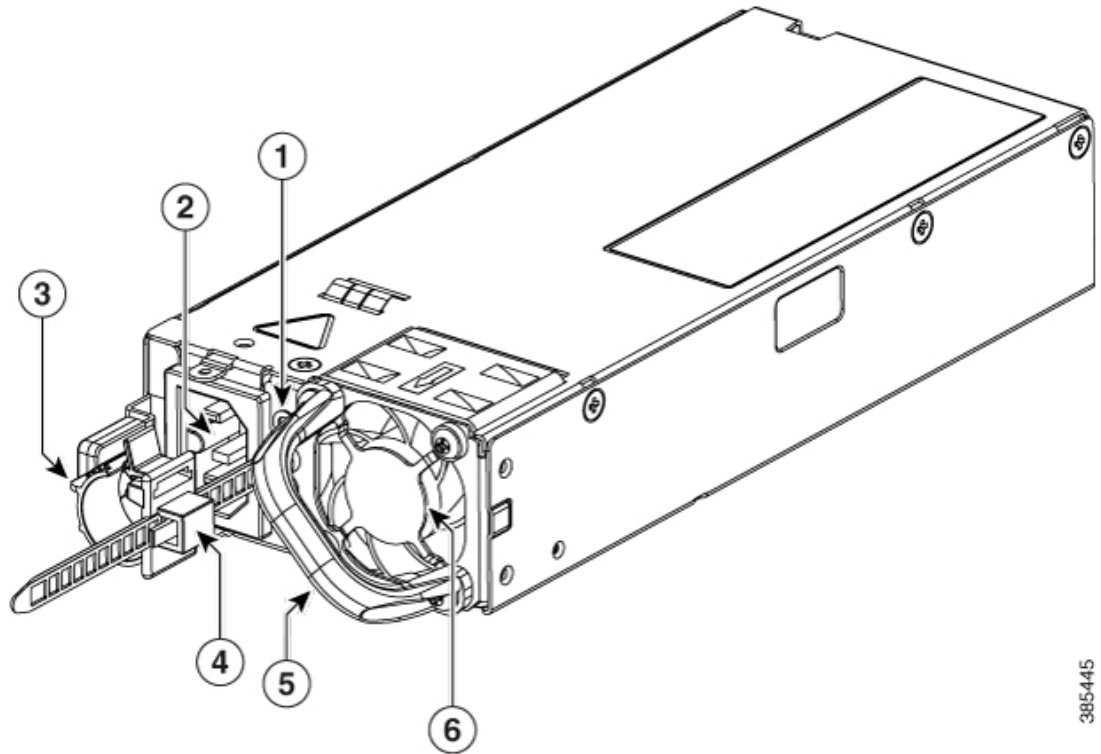

385445

1	PSU LED	4	Power cord retainer
2	AC input connector	5	Release handle
3	Release latch	6	PSU fan

Figure 4: Cisco Catalyst 1600W AC Input Power Supply

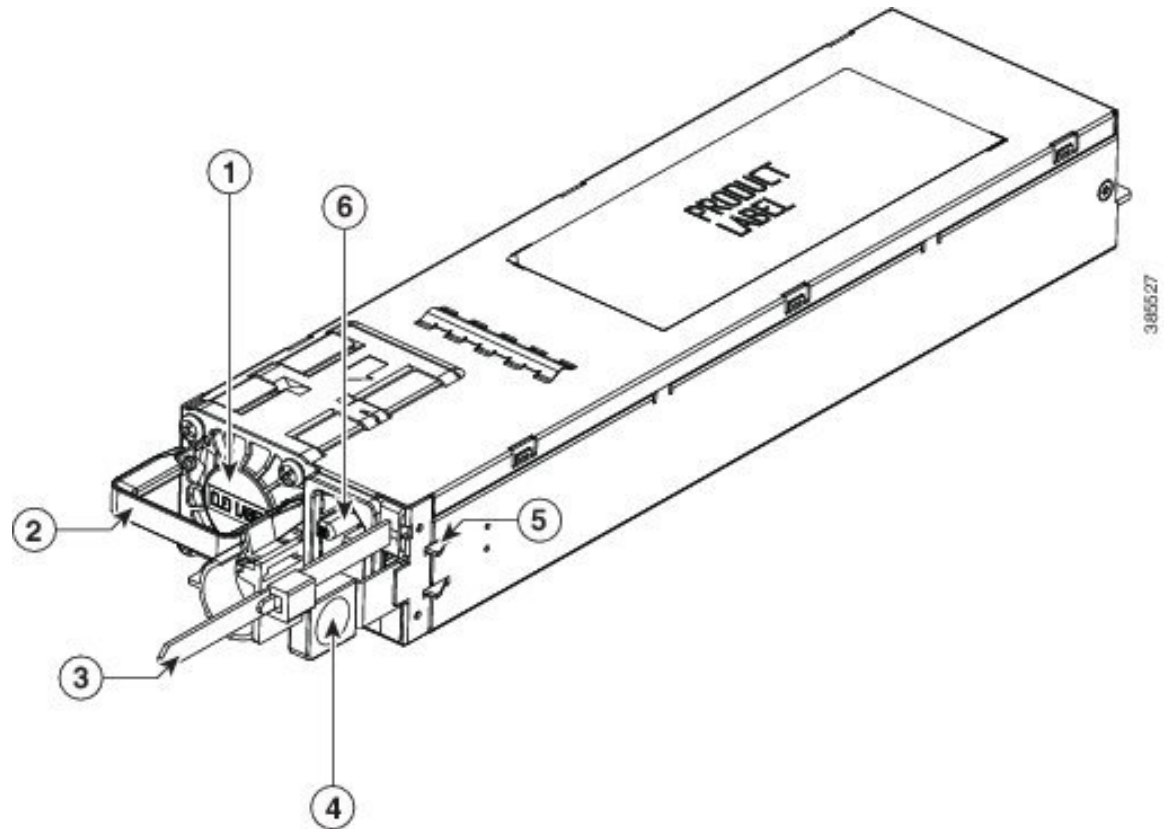

1	PSU fan	4	Release latch
2	Release handle	5	Retainer clips
3	Cable tie	6	AC input connector

Figure 5: Cisco Catalyst 930W DC Input Power Supply

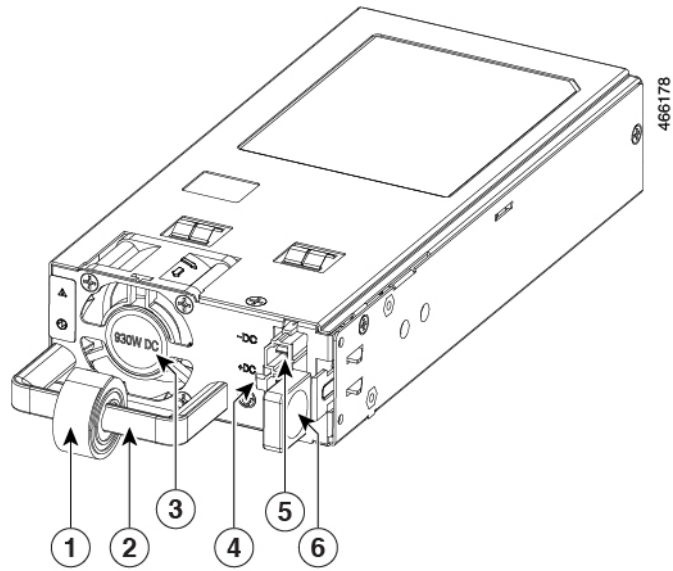

1	Power cord retainer	4	DC+ connector
2	Release handle	5	DC- connector
3	PSU fan	6	Release latch

Figure 6: Cisco Catalyst 950W DC Input Power Supply

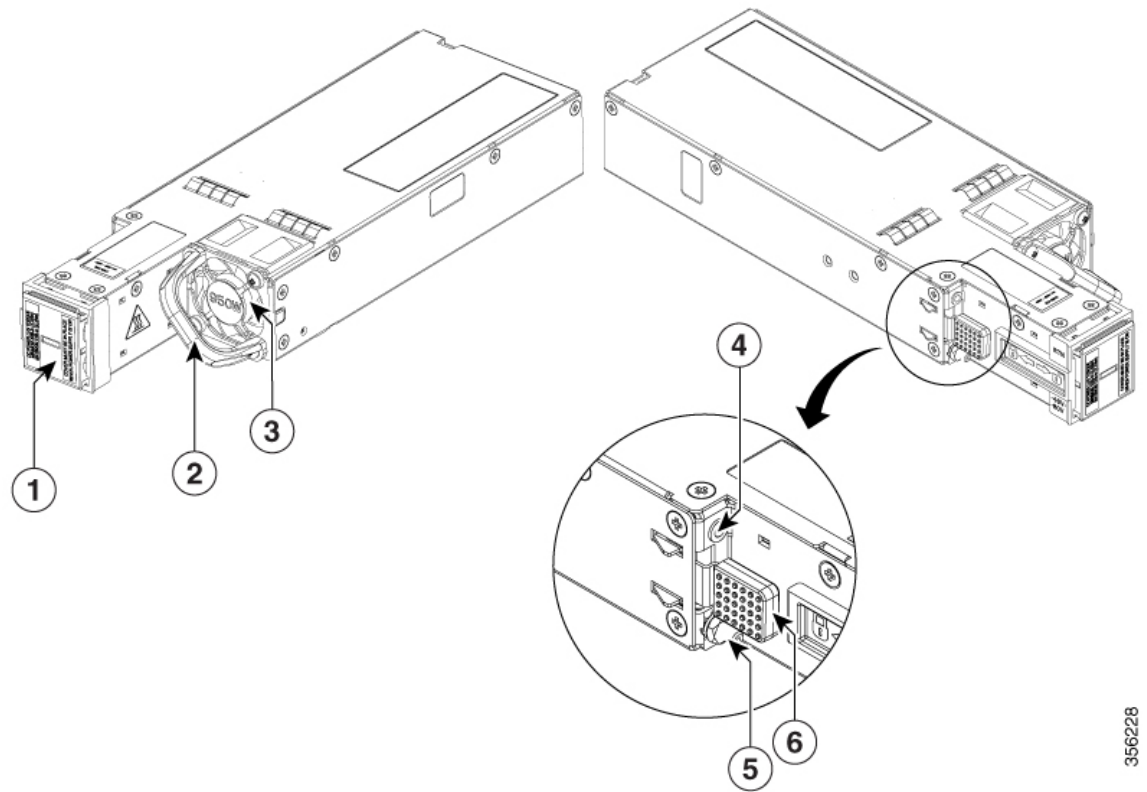

356228

1	DC input connector	4	PSU LED
2	Release handle	5	Grounding terminal
3	PSU fan	6	Release latch

Figure 7: Cisco Catalyst 1600W DC Input Power Supply

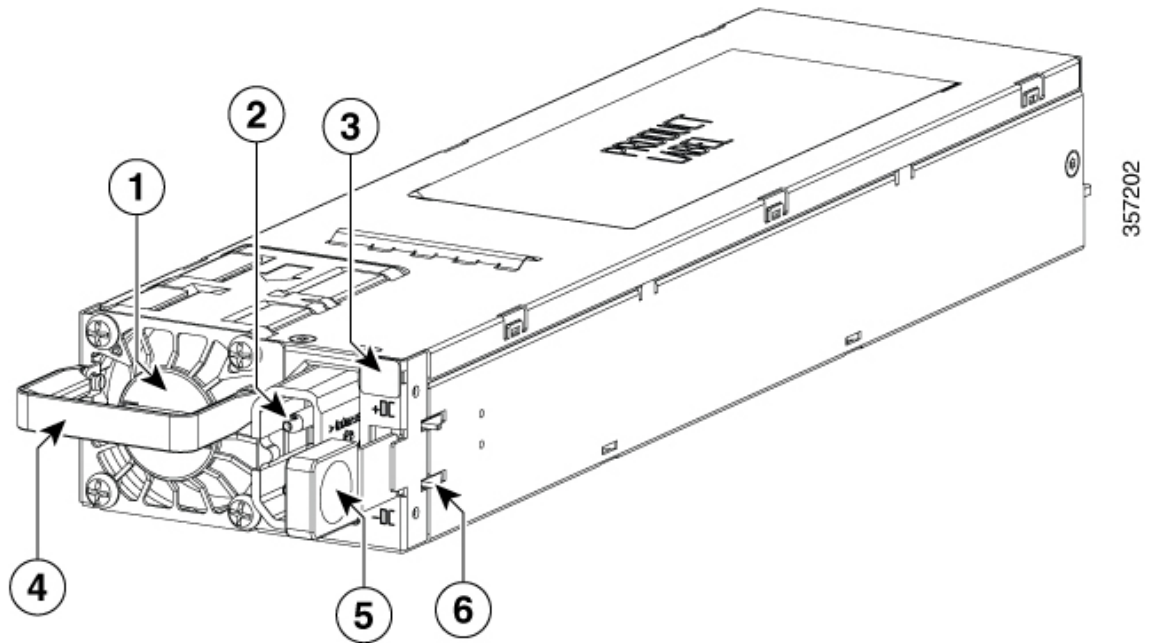

1	PSU fan	4	Release handle
2	DC input connector	5	Release latch
3	PSU LED	6	Retainer clips



Figure 8: Power Supply Slot Cover for Cisco Catalyst 9500 Series Switches

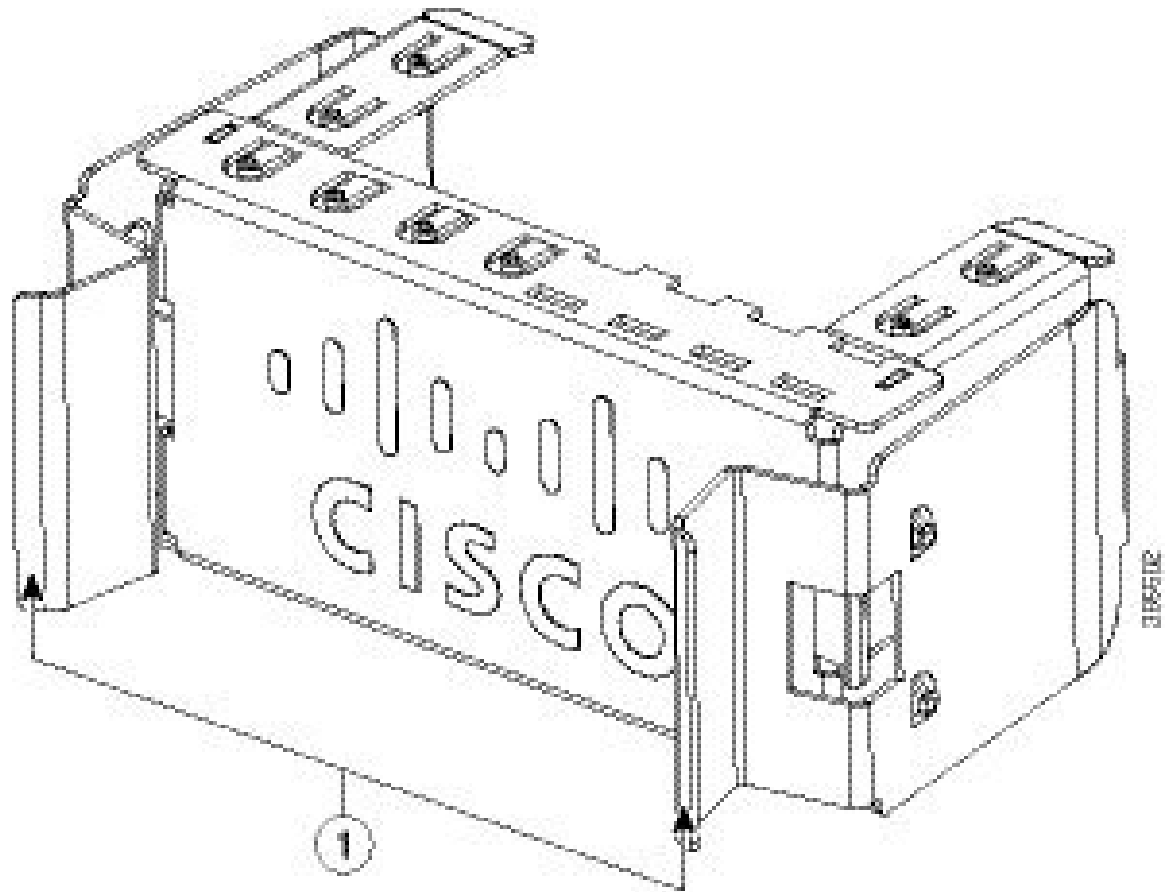

1

Release handles

Figure 9: Power Supply Slot Cover for Cisco Catalyst 9500 High Performance C9500-32C Switch Model

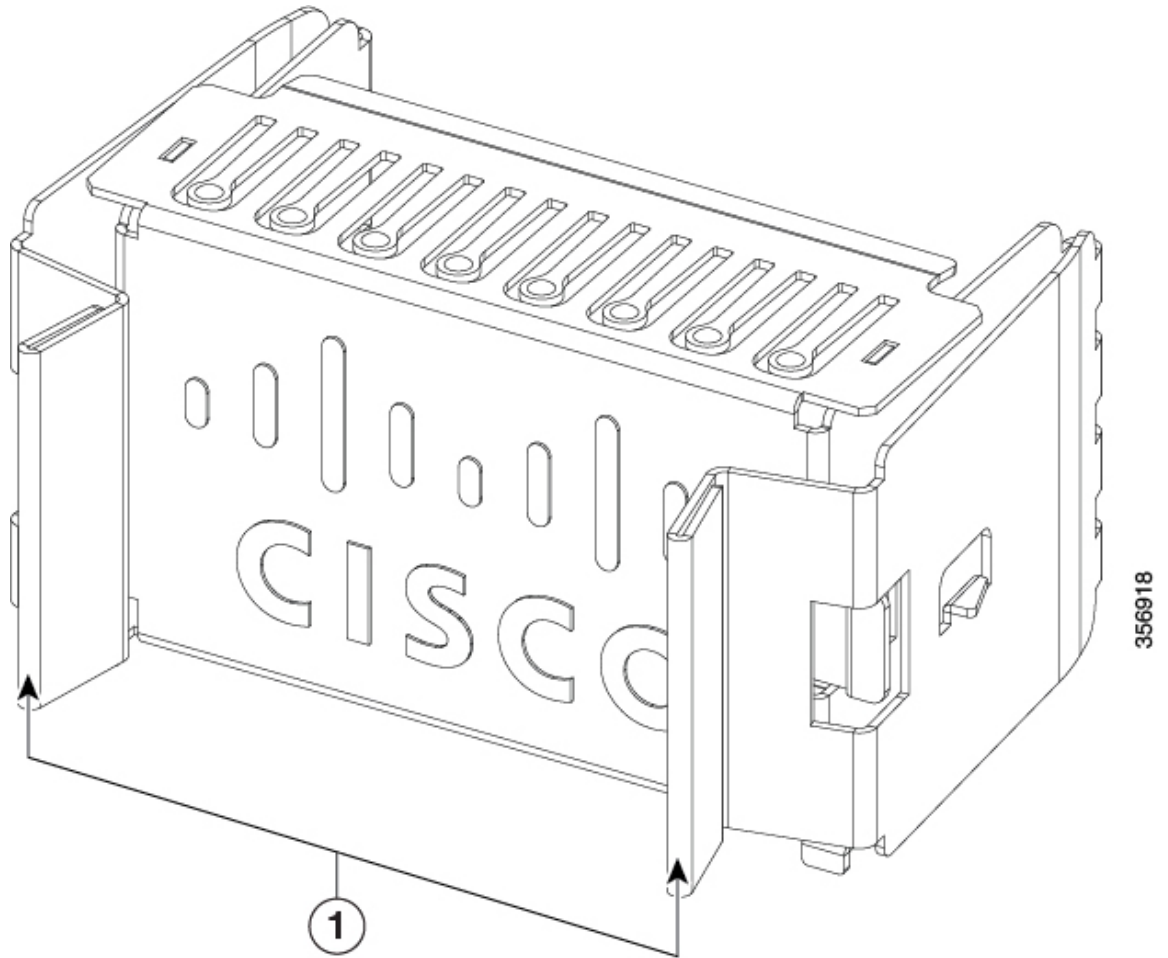

**Figure 10: Power Supply Slot Cover for Cisco Catalyst 9500 High Performance C9500-32QC, C9500-48Y4C and C9500-24Y4C Switch Models**

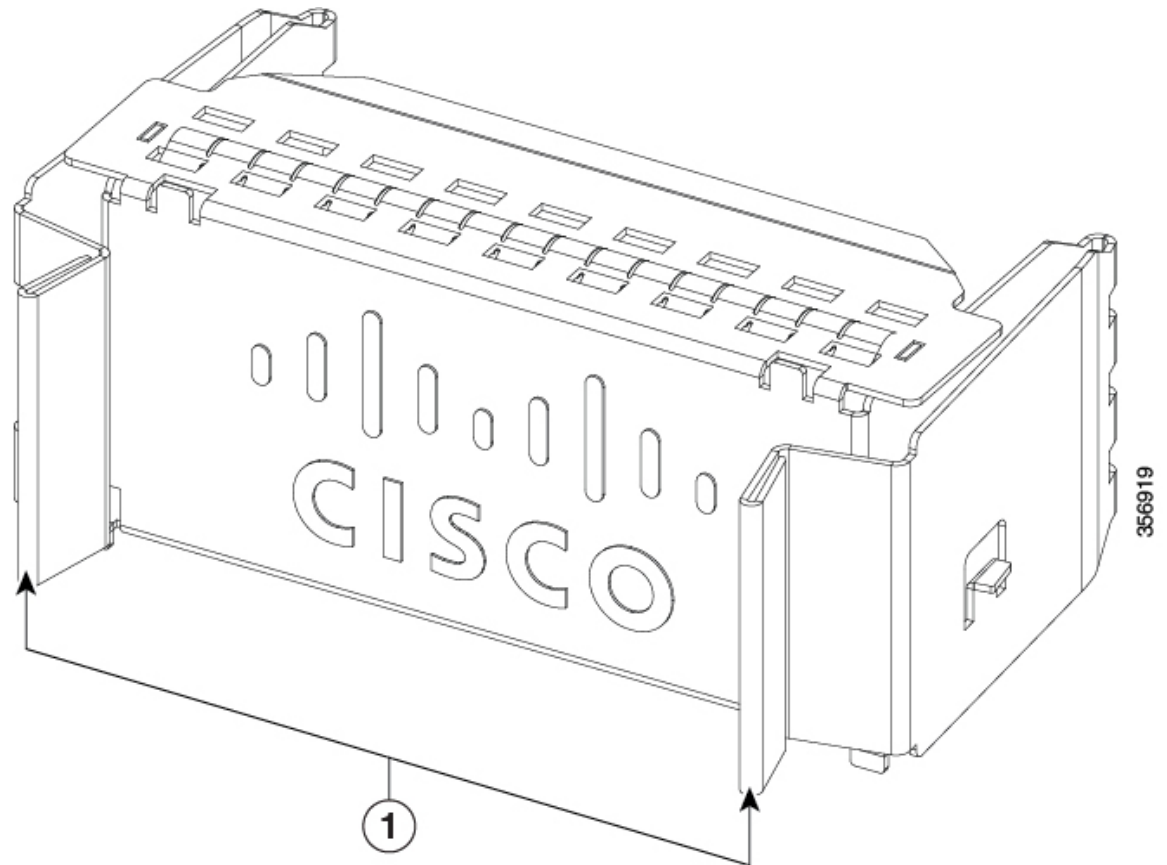

The power supplies can work together in Redundant Mode, in which each power supply operates at approximately 50 percent of its capacity, no greater than 60 percent and no less than 40 percent. If one power supply fails, the other power supply can provide power for the entire system on its own. This is the default and recommended mode.

### Power supply modules LED

The AC and DC power supply modules except the 1600W AC and DC power supply modules, have the following LEDs:

- Green indicating the power status
- Amber indicating the power supply failure

**Table 1: LEDs on the AC/DC power supply modules**

LED	Status	Description
Unlit	Off	No input power.

LED	Status	Description
Green	Blinking	12V aux output is on; 12V main output is off.
	Solid	Both 12V aux output and 12V main output are on; Power supply is functioning normally.
Amber	Blinking	Warning detected. OR AC power cord is not inserted properly.
	Solid	Critical error detected.

The 1600W AC and DC power supply modules have a bi-color (green/amber) LED to indicate the status of the power supplies.

**Table 2: LEDs on the 1600W AC/DC power supply modules**

LED Status	Description
Off	No input power.
Solid amber	Critical error detected; PSU 12V main output is off.
Solid green	Both 12V aux output and 12V main output are on; Power supply is functioning normally.
1Hz blinking amber	Warning detected; PSU 12V main output is on.
2Hz blinking green	PSU 12V main output is off and 12V aux output is on.

## Installation Guidelines

- The switch chassis must be installed in a cabinet or rack that is secured to the data center.
- Remove the power supply from its shipping container and remove any packaging.
- You need the following additional tools and equipment:
  - Nut driver attachment for number 1 Phillips-head screwdriver or ratchet wrench with torque capability (used only for DC-input power supplies).
  - Grounding wire — Size this wire to meet local and national installation requirements. For U.S. installations, you must use an 8-14 AWG copper conductor for AC power supply systems. For installations outside the U.S., consult your local and national electrical codes. The length of the grounding wire depends on the proximity of the switch to proper grounding facilities.
- The chassis is connected to an earth ground.
- You have receptacles for the power sources within reach of the power supply cables.

- If you are connecting to a DC power, check that you are using power cables to connect to the power supply. The wire size applies to the negative [-], and positive [+] cables that connect to negative and positive apertures on the connector. You have to procure the power cable.
- If you are installing more than one DC-input power supply, each must be protected by a dedicated circuit breaker or a fuse that is sized according to the power supply input rating and the local or national electrical code requirements.
- The power sources are rated as follows:
  - For North American AC-input installations—16A with 110V circuits.
  - For North American DC-input installations—(-48 VDC nominal at 37 A in North America (operating range: -40.5 to -56 VDC).
  - For international installations—Size the circuits by local and national standards.
- The power supply is already inserted into the chassis.

**Caution**

Ensure that the power source is OFF. As an added precaution, place the appropriate safety flag and lockout devices at the source power circuit breaker, or place a piece of adhesive tape over the circuit breaker handle to prevent accidental power restoration while you are working on the circuit.

**Warning**

Before performing any of the following procedures, ensure that power is removed from the DC circuit. Statement 1003

## Installing Power Supply

### Inserting the Power Supply

To insert the power supply into the chassis, follow these steps:

#### Procedure

- Step 1** Remove the blank cover and store it for future use.
  - Step 2** Verify that the power supply is not connected to any power sources.
  - Step 3** Hold the handle on the power supply with one hand and position the power supply with its back end at the open power supply bay. See the figure for an example (AC power supply is shown as an example, DC power supply can be installed in the same way).
  - Step 4** Slide the unit all the way into the power supply bay until the release latch on the front of the power supply clicks and prevents you from moving the power supply in or out of the chassis.
- Note** Ensure that the power supply is inserted into the slot in the right direction. If you have inserted the power supply in the reverse direction, the amber LED on the power supply blinks continuously.

Figure 11: Installing the Power Supply

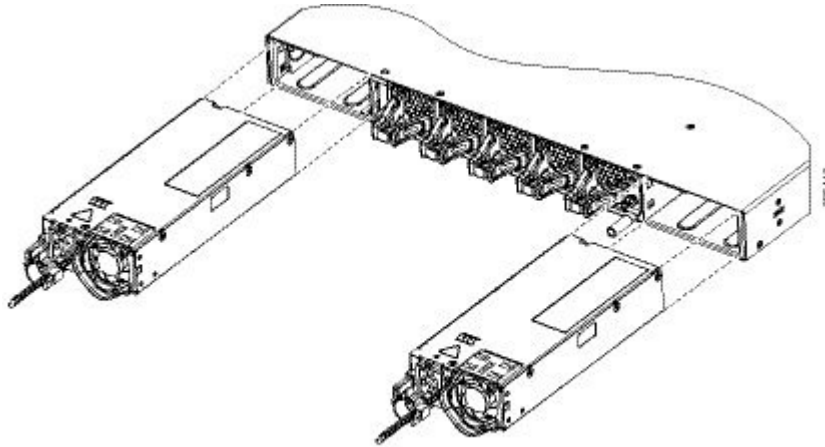

## Connecting to the Power Source

Each power cable is shipped with mating connectors with one of the connectors on the power socket and the other connector on the front panel of the power supply. You follow the same steps to install the AC-input and DC-input power supplies, but you must ground them differently.

- AC-input power supply—It is automatically grounded when you connect its power cable to the power supply and the power source.
- DC-input power supply—You do not connect the power supply directly to the earth ground.

You use one power cord for each power supply to connect the power supply to its power source.

## Connecting to an AC Power Source

To connect to a power source, follow these steps:



**Warning** Take care when connecting units to the supply circuit so that wiring is not overloaded. Statement 1018

### Procedure

- Step 1** Prior to connecting the power supply to a power source, ensure that the chassis is properly grounded.
- Step 2** Plug the power cable into the power supply.
- Step 3** Plug the other end of the power cable into a power source supplied by the data center.

**Note** When using redundant mode, connect each power supply to a separate power source.

**Step 4** Verify that the power supply is receiving power by checking that the LED is on and is amber or red. For more information about the power supply LEDs and the conditions that they indicate, see [Power Supply LEDs](#).

When you first activate the power supply, you can verify the functionality of the LED by checking that LED turns on for a couple of seconds. If the LED is flashing amber or red, check the power connections on the power supply and the power source.

---

## Connecting to a DC Power Source

To connect the DC power supply directly to one or two DC power sources, follow these steps:



**Warning** Before performing any of the following procedures, ensure that power is removed from the DC circuit. **Statement 1003**

---



**Warning** Hazardous voltage or energy may be present on DC power terminals. Always replace cover when terminals are not in service. Be sure uninsulated conductors are not accessible when cover is in place. **Statement 1075.**

---

### Procedure

---

- Step 1** Prior to connecting the power supply to a power source, ensure that the chassis is properly grounded.
- Step 2** Plug the DC power cable into the DC power supply.
- Step 3** Turn off the power at the circuit breakers for the portions of the DC grid power that you are connecting to and verify that all of the LEDs on the DC grid power supplies are off.
- Step 4** Depending on the power supply installed, install the two cables from the DC power supply to the DC power source as follows:
- If you are using C9K-PWR-1600WDC-R or C9K-PWR-930WDC-R, do the following:
    - a. If the unconnected end of each power cable is not stripped off of its insulation for the last 0.75 inches (19 mm), use wire strippers to remove that amount of insulation.
    - b. Attach the negative cables to the negative terminals of a DC power source, and attach the positive cables to the positive terminals of the same power source.

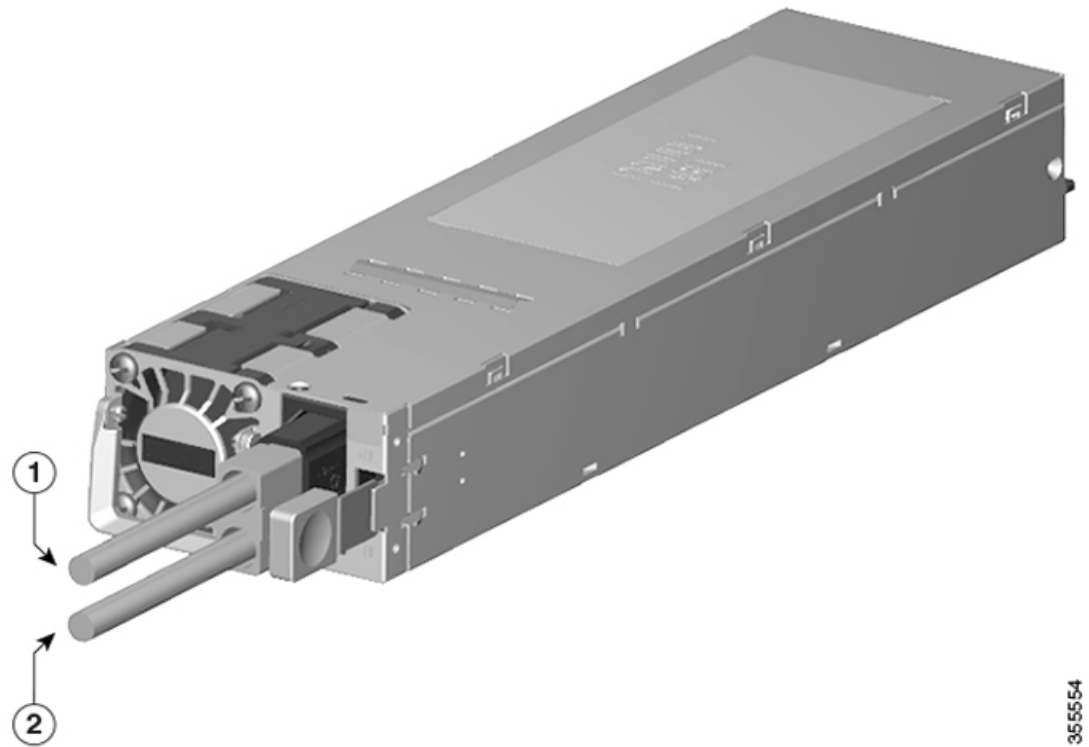

355554

1	Positive terminal	2	Negative terminal
---	-------------------	---	-------------------

- If you are using PWR-C4-950WDC-R, do the following:
  - a. Remove the safety cover on the terminal box on the front of the DC power supply.



Figure 12: Remove the Safety Cover

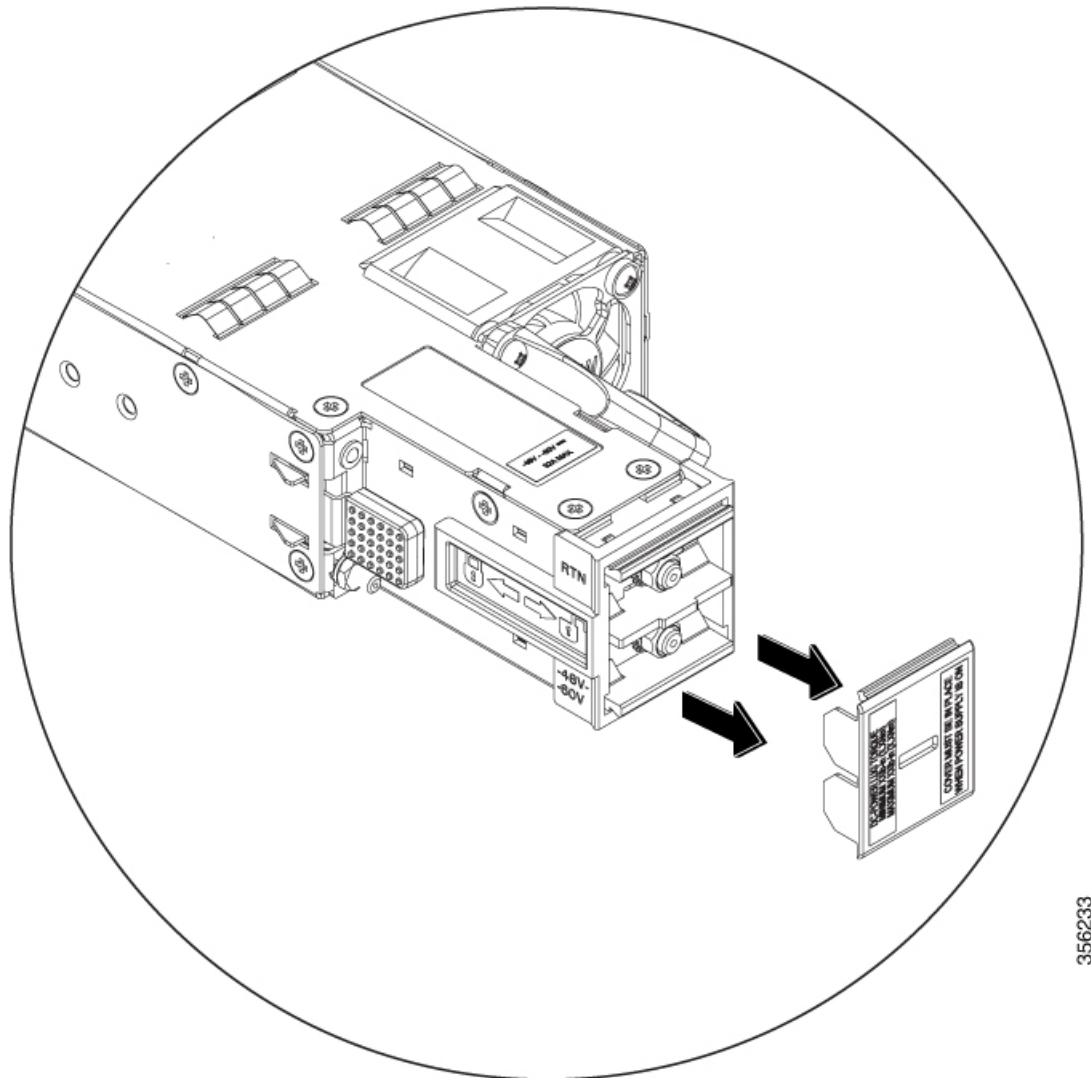

- b. Loosen and unscrew the two nuts on the terminal box. The terminal box has two slots for power terminals. Each terminal has a nut that you use to fasten the power cable to the terminal.

356233

Figure 13: Removing the Nuts on the Terminal Box

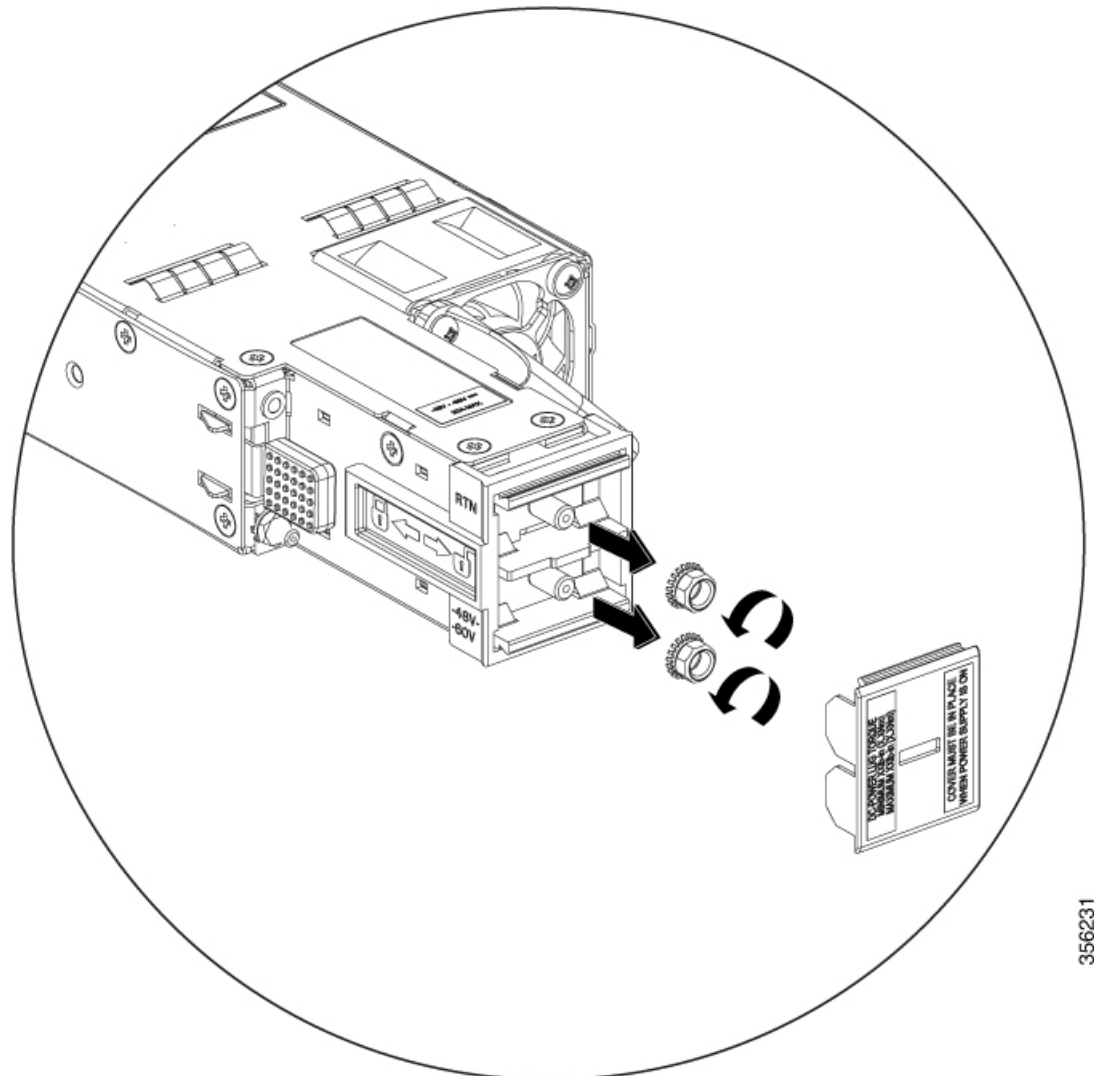

356231

- c. Secure the positive (+) DC power cable lug to the RTN terminal and the negative (-) DC power cable lug to the -48V terminal with the nuts.  
To tighten the nuts, apply torque between 7 lbf.in (0.8Nm) and 10lbf.in (1.1 Nm) to each nut.
- d. Replace the safety cover over the terminal box on the DC power supply.

**Step 5**

Verify that the power supply is receiving power by checking that the LED is on and is amber or red. For more information about the power supply LEDs and the conditions that they indicate, see [Power Supply LEDs](#).

When you first activate the power supply, you can verify the functionality of the LED by checking that LED turns on for a couple of seconds. If the LED is flashing amber or red, check the power connections on the power supply and the power source.

## Removing Power Supplies

### Procedure

---

- Step 1** Turn off the power to the power supply that you are removing, as follows:
- If you are removing a DC-input power supply, ensure that the power is turned off at the power source by turning off the power for that circuit.
- Step 2** Detach the power and ground cables, as follows:
- For the AC-input power supply, unplug the power cables that are attached to the power supply and the power source.
  - For the DC-input power supply, remove the power cables from the power supply and the power source.
- Step 3** Remove the power supply from the chassis, as follows:
- a) Press the ejector latch on the right of the power supply.
  - b) Pull the power supply partially out of the slot by its handle.
  - c) Pull the power supply fully from the slot.
- Caution** If you intend to operate the switch without installing another power supply in the empty slot, then you must reinstall the blank cover over the empty power supply slot to ensure proper air flow in the system and for safety reasons.
- 

## Finding the Serial Number

If you contact Cisco Technical Assistance, you need to know the serial number. These figures show where the serial number is located. You can also use the **show inventory EXEC** command to see the serial number.

**Figure 14: Serial Number on the Power Supply**

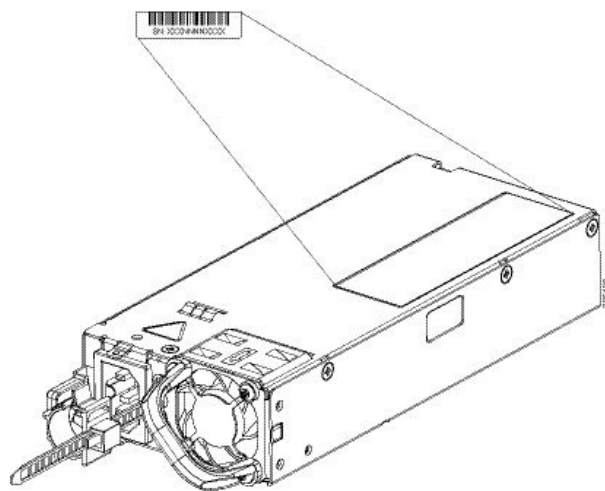

# Installing a Fan Module

## Fan Module Overview

Depending on the switch model, five individual fan modules (C9500-32C and Catalyst 9500 Series switches) or two fan trays with dual-stacked fans (C9500-24Y4C, C9500-48Y4C and C9500-32QC) are available. In models using 5 fan modules, the switch can operate with 4 operational fans and 1 nonfunctional fan. Any failed fan should be replaced as soon as possible to avoid service interruption due to a second fan fault.

For the switch to boot-up, ensure the following conditions are met.

- the switches using FAN-T4-R and C9K-T2-FANTRAY= modules must at a minimum have 4 fans operating normally
- the switches using C9K-T1-FANTRAY modules must have 2 fan tray modules with all the fans operating normally

If the switch fails to meet the minimum number of required fans, the switch shuts down automatically to prevent the system from overheating.

Part Number	Supported Switches	Description
FAN-T4-R=	Cisco Catalyst 9500 Series switches: C9500-12Q C9500-24Q C9500-40X C9500-16X	<ul style="list-style-type: none"> <li>• Each switch contains five individual fan modules operating in N+1 redundancy mode.</li> <li>• Type 4 hot-swappable fan module.</li> </ul>
C9K-T2-FANTRAY=	Cisco Catalyst 9500 Series High Performance switch: C9500-32C	
C9K-T1-FANTRAY=	Cisco Catalyst 9500 Series High Performance switches: C9500-32QC C9500-48Y4C C9500-24Y4C	<ul style="list-style-type: none"> <li>• Each switch contains two fan tray units with dual-stacked fans.</li> <li>• Functions in the event of the failure of one of the fans in the fan tray unit. The individual fans are not replaceable; you must replace the fan unit.</li> </ul>

Figure 15: FAN-T4-R Fan Module and C9K-T2-FANTRAY=

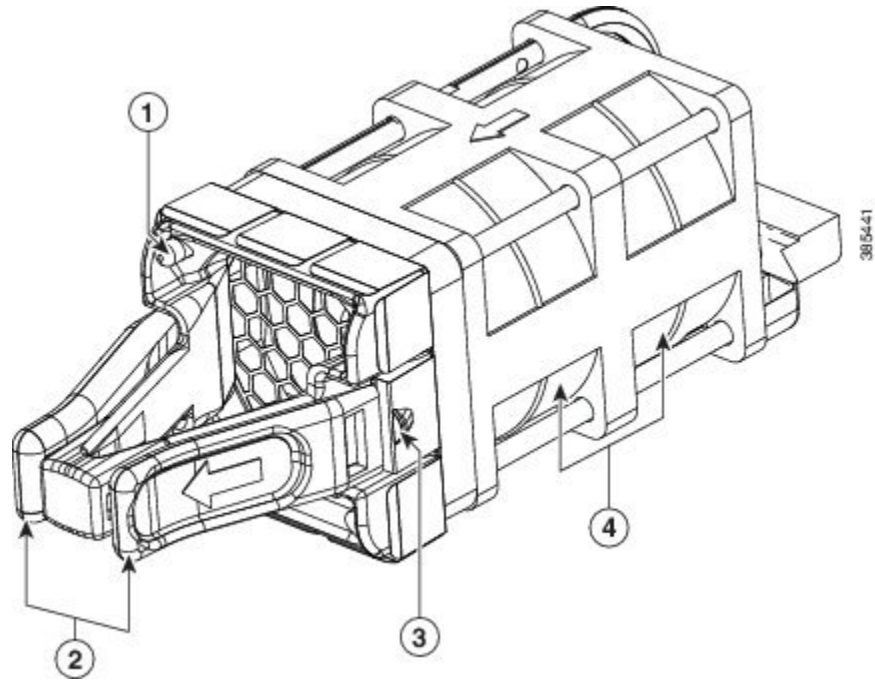

1	Fan assembly levers	3	Fan LED
2	Fan	4	Fan assembly retention latch

Figure 16: Fan Tray Unit with Dual-Stacked Fans

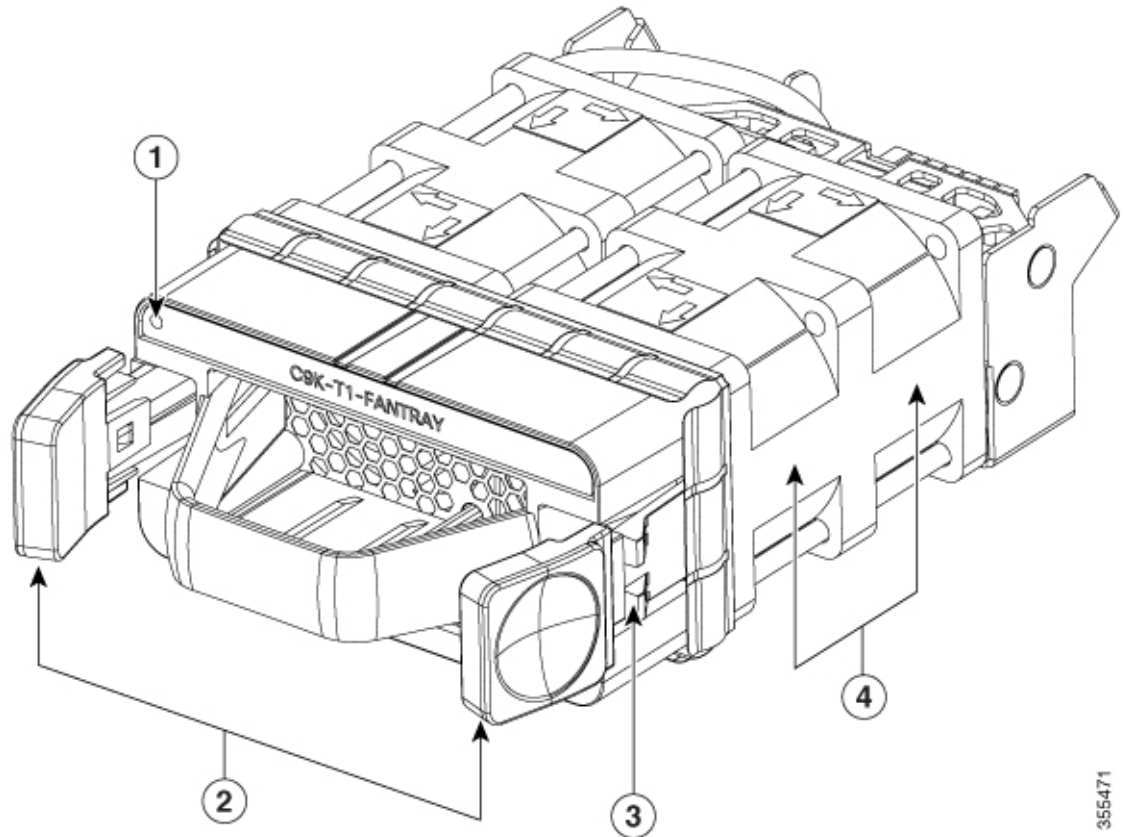

355471

1	Fan LED	3	Fan assembly retention latch
2	Fan assembly levers	4	Fans

## Installation Guidelines

Observe these guidelines when removing or installing a fan module:

- Do not force the fan module into the slot. This can damage the pins on the switch if they are not aligned with the module.
- A fan module that is only partially connected to the switch can disrupt the system operation.
- The switch supports hot swapping of the fan module. You can remove and replace the module without interrupting normal switch operation.



**Warning**

Only trained and qualified personnel should be allowed to install, replace, or service this equipment. Statement 1030

## Installing a Fan Module

### Procedure

---

- Step 1** Pinch the fan module release handle and slide the module out.
- Caution** You should replace the fan module within 5 minutes to avoid overheating the switch.
- Step 2** Install the fan module in the fan slot, and firmly push it into the slot, applying pressure to the end of the module, not the extraction handles. When correctly inserted, the fan module is flush with the switch rear panel. When the fan is operating, a green LED is on in the top left corner of the fan.
- Warning** Do not reach into a vacant slot when installing or removing a module. Exposed circuitry is an energy hazard. Statement 206

*Figure 17: Installing the Fan Module on a Cisco Catalyst 9500 Series Switch*

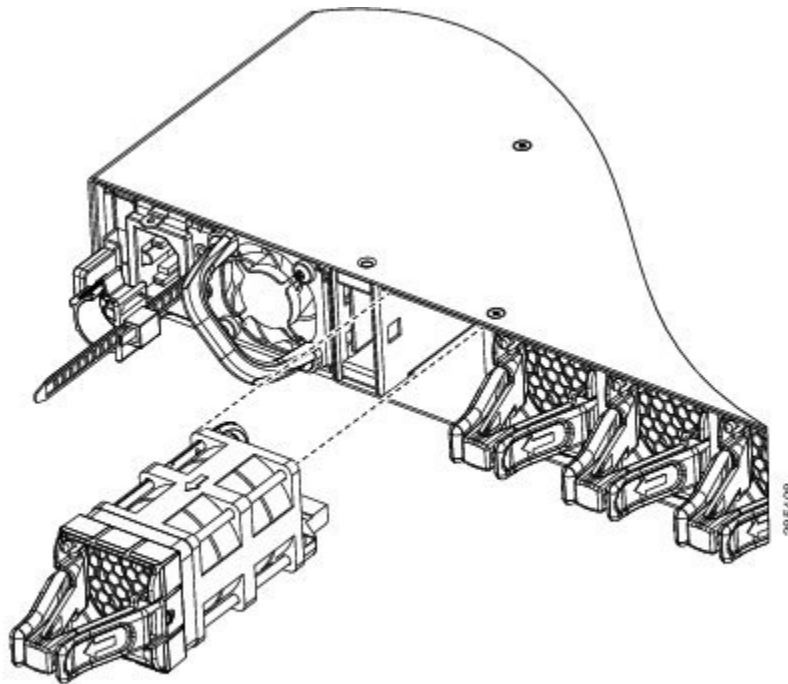
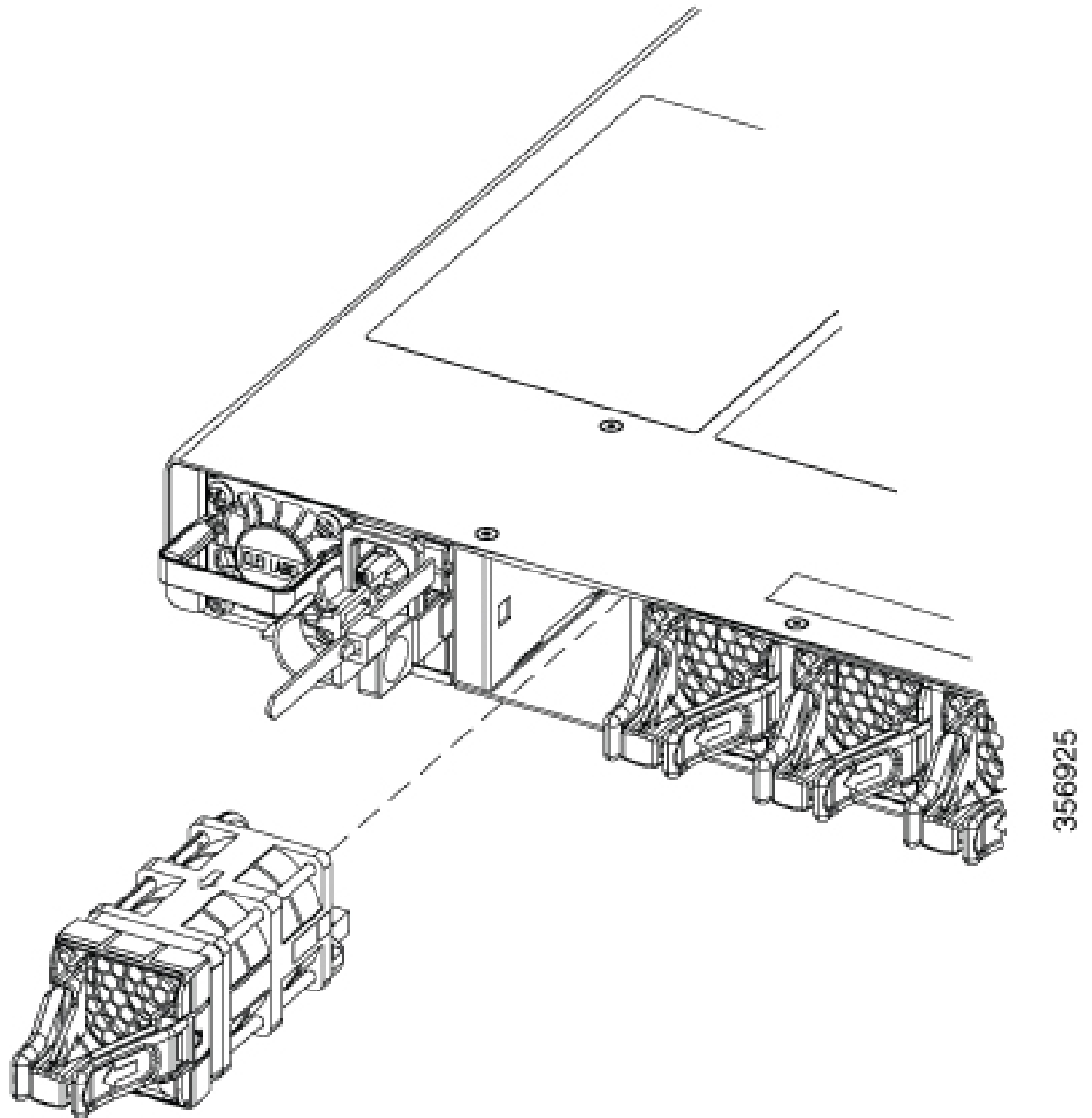
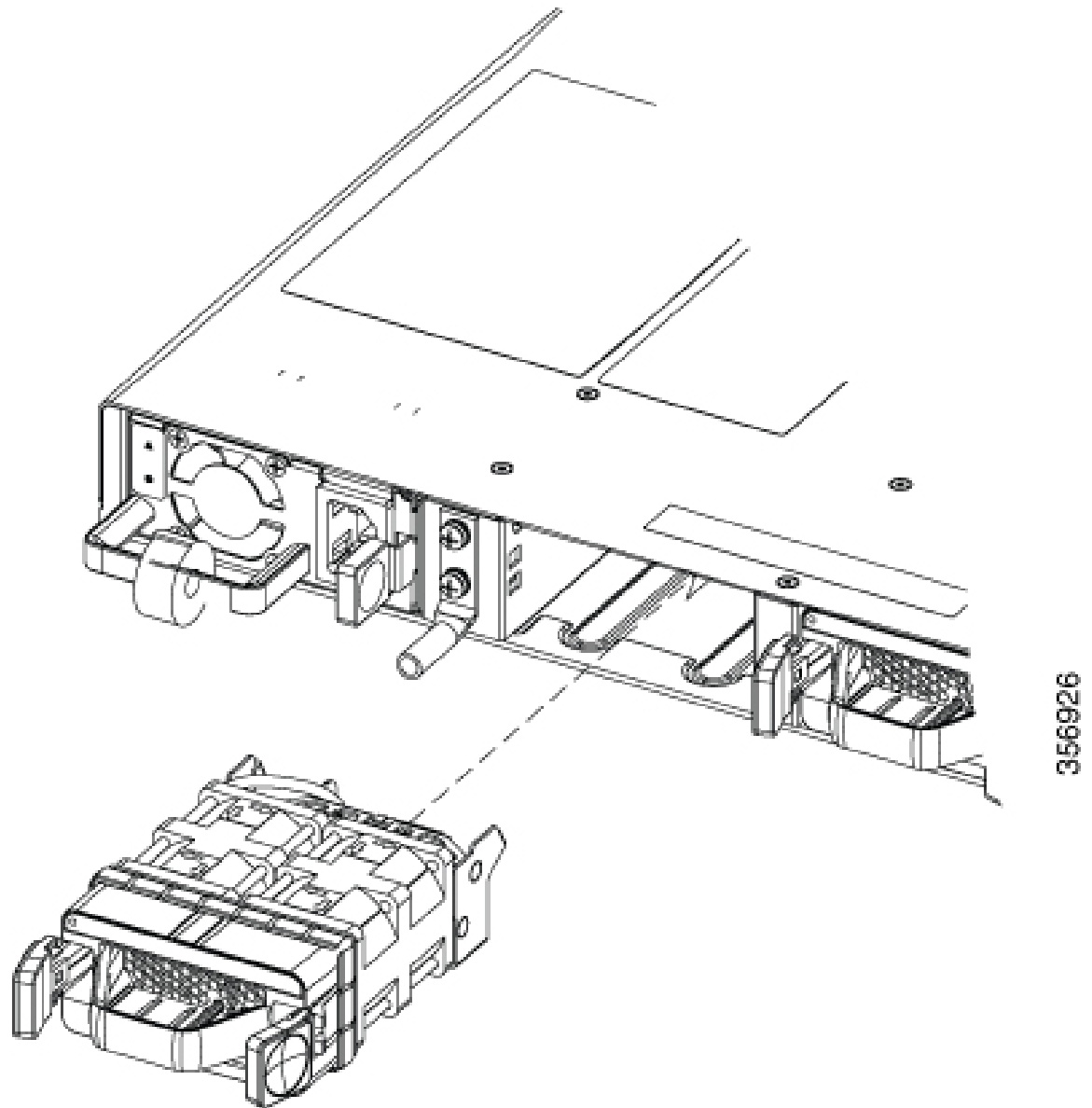

Figure 18: Installing the Fan Module on Cisco Catalyst 9500 High Performance C9500-32C Switch Model





*Figure 19: Installing the Fan Module on Cisco Catalyst 9500 High Performance C9500-32QC, C9500-48Y4C and C9500-24Y4C Switch Models*



## Finding the Fan Module Serial Number

If you contact Cisco Technical Assistance regarding a fan module, you need to know the fan module serial number. See the following illustration to find the serial number.

Figure 20: Fan Module Serial Number on Cisco Catalyst 9500 Series switches and High Performance Switch C9500-32C Switch

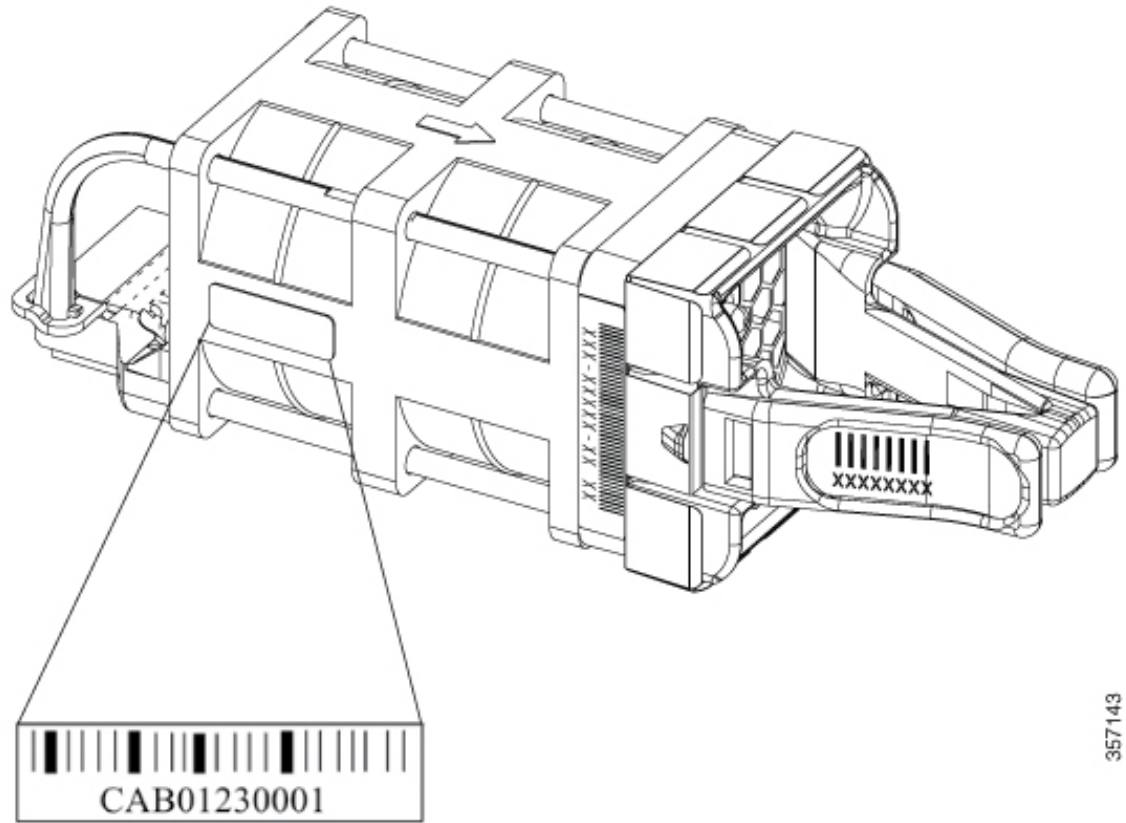

357143

**Figure 21: Fan Module Serial Number on Cisco Catalyst 9500 High Performance C9500-32QC, C9500-48Y4C and C9500-24Y4C Switch Models**

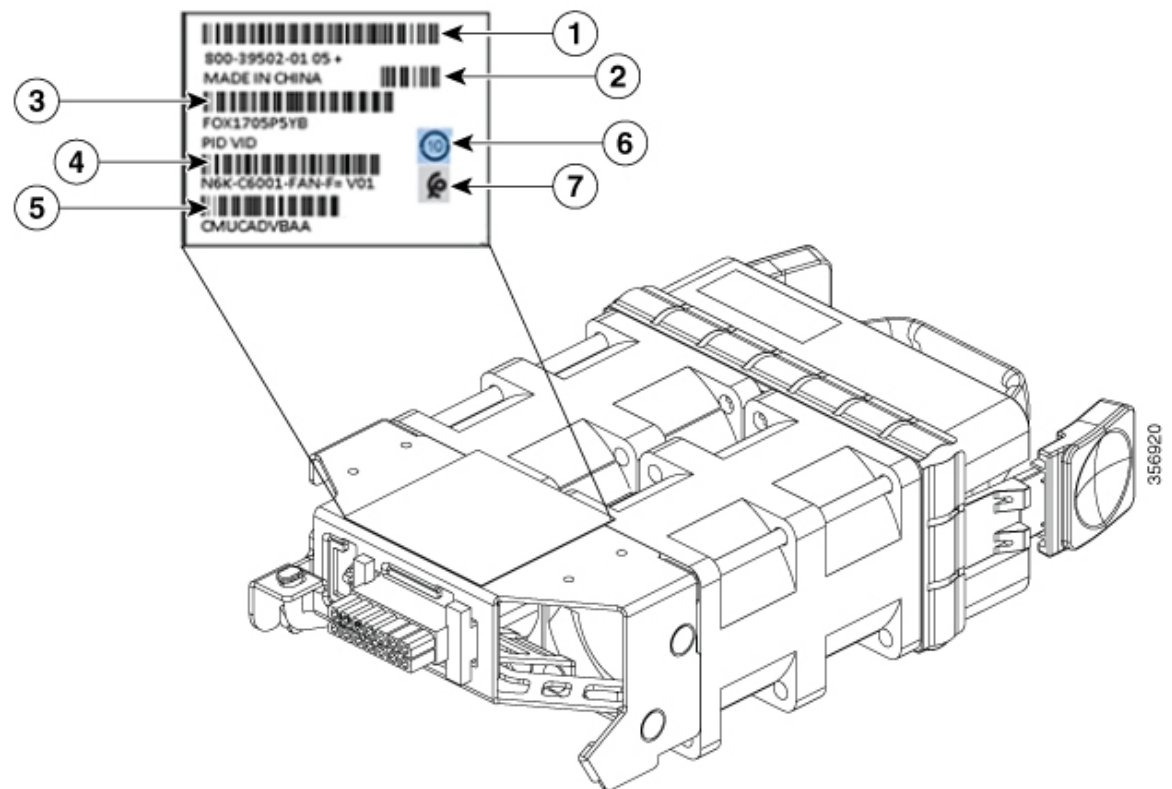

1	Product Number	5	CLEI
2	Country of Origin	6	China RoHS
3	Serial Number	7	Morocco Logo
4	PID/VID	-	-

## Installing an SSD Module

### SATA SSD Module Overview

SATA SSD module is available as a field-replaceable unit (FRU). The SSD module has a button which facilitates hot-swapping of the module. To prevent data loss, press the hot-swap button to request removal and wait for the system to confirm safe-removal by turning off the status LED.

Figure 22: SATA SSD Supported on Cisco Catalyst 9500 Series High Performance Switches

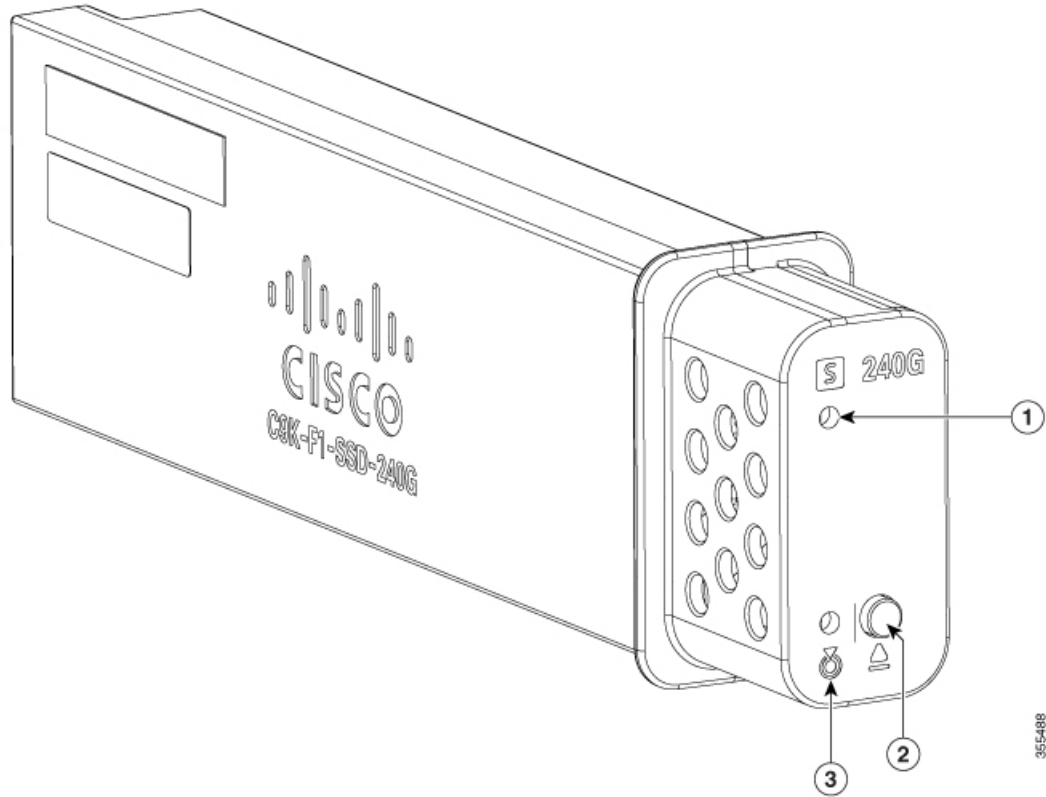

1	Status LED	3	Blue beacon LED
2	Hot-swap button	-	-

The following table lists the SATA SSD modules supported on Cisco Catalyst 9500 Series High Performance Switches.

SATA SSD	Description
C9K-F1-SSD-240G	Cisco Catalyst 9500 Series 240GB SATA memory
C9K-F1-SSD-480G	Cisco Catalyst 9500 Series 480GB SATA memory
C9K-F1-SSD-960G	Cisco Catalyst 9500 Series 960GB SATA memory

## Installing an SSD Module

### Procedure

- 
- Step 1** Remove the blank cover on the SSD module slot on the switch and store it for future use.

- Step 2** Insert the SSD module into the USB 3.0 SSD module slot, and firmly push it into the slot.

*Figure 23: Installing an SSD Module on a Cisco Catalyst 9500 Series High Performance Switch*

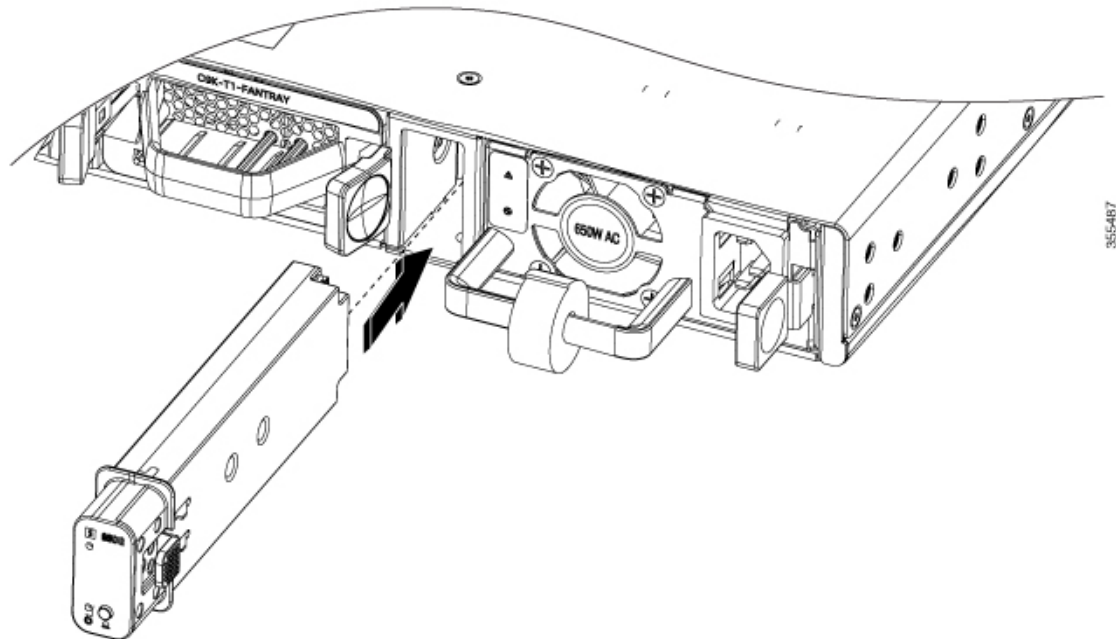

- Step 3** On Cisco Catalyst 9500 Series High Performance Switches, verify that the LED on the SSD module turns solid green.

## Removing an SSD Module

### Procedure

- Step 1** On Cisco Catalyst 9500 Series High Performance switches, press and hold the hot-swap button on the SSD module for at least four seconds.

The system powers down the SSD module and the port and the LED turns off indicating that the module is ready for removal.

Also, the switch console displays the following messages indicating safe removal.

```
*Mar 12 11:22:22.285: %IOSXE-3-PLATFORM: R0/0: kernel: ata1: irq_stat
0x00400040, connection status changed
*Mar 12 11:22:28.310: %IOSXE-4-PLATFORM: R0/0: kernel: ata1: limiting
SATA link speed to 1.5 Gbps
*Mar 12 11:22:33.613: %IOSXE-4-PLATFORM: R0/0: kernel: ata1.00: disabled
```

- Step 2** Remove the SSD module from the module slot and insert the blank slot cover.

If you are replacing the SSD module, insert the new module into the slot. For more information, see [Installing an SSD Module, on page 28](#).

---