



Configuring Layer 2 Protocol Tunneling

- [Prerequisites for Layer 2 Protocol Tunneling, on page 1](#)
- [Information About Layer 2 Protocol Tunneling, on page 1](#)
- [How to Configure Layer 2 Protocol Tunneling, on page 5](#)
- [How to Configure Layer 2 Protocol Tunneling for EtherChannels, on page 7](#)
- [Configuration Examples for Layer 2 Protocol Tunneling, on page 12](#)
- [Monitoring Tunneling Status, on page 14](#)
- [Feature History for Layer 2 Protocol Tunneling, on page 15](#)

Prerequisites for Layer 2 Protocol Tunneling

The following sections list prerequisites and considerations for configuring Layer 2 protocol tunneling.

To configure Layer 2 point-to-point tunneling to facilitate the automatic creation of EtherChannels, you need to configure both the SP (service-provider) edge switch and the customer device.

Information About Layer 2 Protocol Tunneling

The following sections provide information about Layer 2 protocol tunneling:

Layer 2 Protocol Tunneling Overview

Customers at different sites that are connected across a service-provider network need to use various Layer 2 protocols to scale their topologies to include all remote sites, as well as the local sites. STP must run properly, and every VLAN should build a proper spanning tree that includes the local site and all remote sites across the service-provider network. Cisco Discovery Protocol (CDP) must discover neighboring Cisco devices from local and remote sites. VLAN Trunking Protocol (VTP) must provide consistent VLAN configuration throughout all sites in the customer network.

When protocol tunneling is enabled, edge device on the inbound side of the service-provider network encapsulate Layer 2 protocol packets with a special MAC address and send them across the service-provider network. Core devices in the network do not process these packets but forward them as normal packets. Layer 2 protocol data units (PDUs) for CDP, STP, or VTP cross the service-provider network and are delivered to customer devices on the outbound side of the service-provider network. Identical packets are received by all customer ports on the same VLANs with these results:

- Users on each of a customer's sites can properly run STP, and every VLAN can build a correct spanning tree based on parameters from all sites and not just from the local site.
- CDP discovers and shows information about the other Cisco devices that are connected through the service-provider network.
- VTP provides consistent VLAN configuration throughout the customer network, propagating to all devices through the service provider.

Layer 2 protocol tunneling can be used independently or can enhance IEEE 802.1Q tunneling. If protocol tunneling is not enabled on IEEE 802.1Q tunneling ports, remote devices at the receiving end of the service-provider network do not receive the PDUs and cannot properly run STP, CDP, and VTP. When protocol tunneling is enabled, Layer 2 protocols within each customer's network are totally separate from those running within the service-provider network. Customer devices on different sites that send traffic through the service-provider network with IEEE 802.1Q tunneling achieve complete knowledge of the customer's VLAN. If IEEE 802.1Q tunneling is not used, you can still enable Layer 2 protocol tunneling by connecting to the customer device through access ports and by enabling tunneling on the service-provider access port.

For example, in the following figure (Layer 2 Protocol Tunneling), Customer X has four switches in the same VLAN, that are connected through the service-provider network. If the network does not tunnel PDUs, switches on the far ends of the network cannot properly run STP, CDP, and VTP. For example, STP for a VLAN on a switch in Customer X, Site 1, will build a spanning tree on the switches at that site without considering convergence parameters based on Customer X's switch in Site 2. This could result in the topology that is shown in the Layer 2 Network Topology without Proper Convergence figure.

Figure 1: Layer 2 Protocol Tunneling

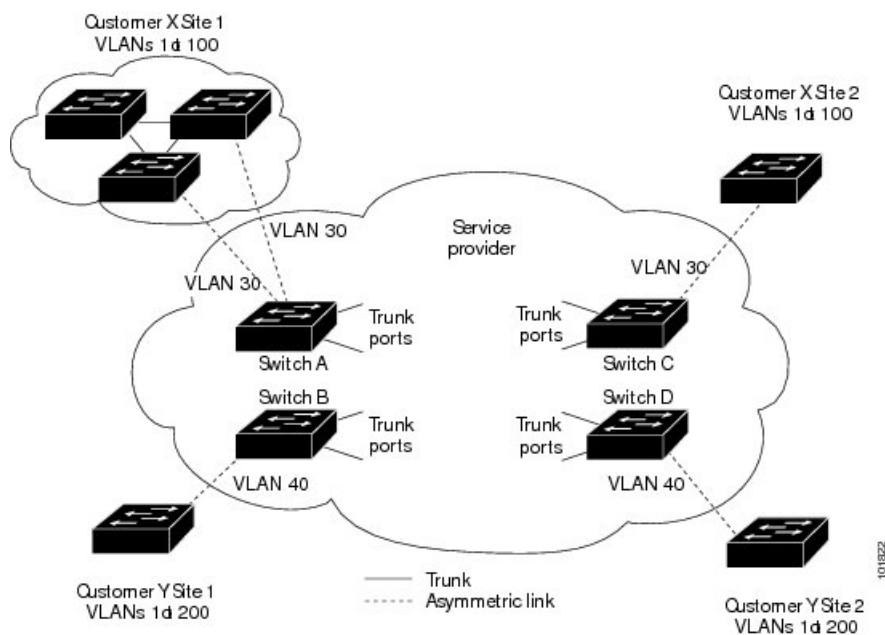
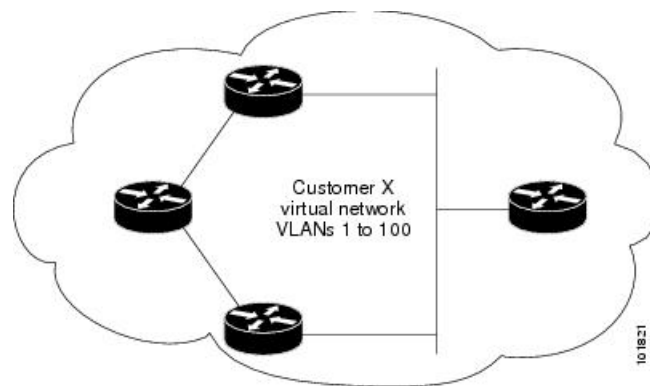

Figure 2: Layer 2 Network Topology Without Proper Convergence



Layer 2 Protocol Tunneling on Ports

You can enable Layer 2 protocol tunneling (by protocol) on the ports that are connected to the customer in the edge devices of the service-provider network. The service-provider edge devices connected to the customer device perform the tunneling process. Edge device tunnel ports are connected to customer IEEE 802.1Q trunk ports. Edge device access ports are connected to customer access ports. The edge devices connected to the customer device perform the tunneling process.

You can enable Layer 2 protocol tunneling on ports that are configured as access ports or tunnel ports or trunk ports. You cannot enable Layer 2 protocol tunneling on ports that are configured in either **switchport mode dynamic auto** mode (the default mode) or **switchport mode dynamic desirable** mode.

The device supports Layer 2 protocol tunneling for CDP, STP, and VTP. For emulated point-to-point network topologies, it also supports PAgP, LACP, LLDP, and UDLD protocols.



Note PAgP, LACP, and UDLD protocol tunneling are only intended to emulate a point-to-point topology. An erroneous configuration that sends tunneled packets to many ports could lead to a network failure.

When the Layer 2 PDUs that entered the service-provider inbound edge device through a Layer 2 protocol-enabled port exit through the trunk port into the service-provider network, the device overwrites the customer PDU-destination MAC address with a well-known Cisco proprietary multicast address (01-00-0c-cd-cd-d0). If IEEE 802.1Q tunneling is enabled, packets are also double-tagged; the outer tag is the customer metro tag, and the inner tag is the customer's VLAN tag. The core devices ignore the inner tags and forward the packet to all trunk ports in the same metro VLAN. The edge devices on the outbound side restore the proper Layer 2 protocol and MAC address information and forward the packets to all tunnel or access ports in the same metro VLAN. Therefore, the Layer 2 PDUs remain intact and are delivered across the service-provider infrastructure to the other side of the customer network.

See the Layer 2 Protocol Tunneling figure in [Layer 2 Protocol Tunneling Overview](#), with Customer X and Customer Y in access VLANs 30 and 40, respectively. Asymmetric links connect the customers in Site 1 to edge switches in the service-provider network. The Layer 2 PDUs (for example, BPDUs) coming into Switch B from Customer Y in Site 1 are forwarded to the infrastructure as double-tagged packets with the well-known MAC address as the destination MAC address. These double-tagged packets have the metro VLAN tag of 40, as well as an inner VLAN tag (for example, VLAN 100). When the double-tagged packets enter Switch D, the outer VLAN tag 40 is removed, the well-known MAC address is replaced with the respective Layer 2

protocol MAC address, and the packet is sent to Customer Y on Site 2 as a single-tagged frame in VLAN 100.

You can also enable Layer 2 protocol tunneling on access ports on the edge switch that is connected to access or trunk ports on the customer switch. In this case, the encapsulation and decapsulation process are the same as described in the previous paragraph, except that the packets are not double-tagged in the service-provider network. The single tag is the customer-specific access VLAN tag.

In switch stacks, Layer 2 protocol tunneling configuration is distributed among all member switches. Each member switch that receives an ingress packet on a local port encapsulates or decapsulates the packet and forwards it to the appropriate destination port. On a single switch, ingress Layer 2 protocol-tunneled traffic is sent across all local ports in the same VLAN on which Layer 2 protocol tunneling is enabled. In a stack, packets received by a Layer 2 protocol-tunneled port are distributed to all ports in the stack that are configured for Layer 2 protocol tunneling and are in the same VLAN. All Layer 2 protocol tunneling configuration is handled by the active switch and distributed to all member switches in the stack.

Layer 2 Protocol Tunneling for EtherChannels

In an SP network, you can use Layer 2 protocol tunneling to enhance the creation of EtherChannels by emulating a point-to-point network topology. When you enable protocol tunneling (PAgP or LACP) on the SP switch, remote customer switches receive the PDUs and can negotiate the automatic creation of EtherChannels.

For example, in the following figure (Layer 2 Protocol Tunneling for EtherChannels), Customer A has two switches in the same VLAN that are connected through the SP network. When the network tunnels PDUs, switches on the far ends of the network can negotiate the automatic creation of EtherChannels without needing dedicated lines.

While configuring Layer 2 Protocol Tunneling on trunk ports, both the trunk ports on the SP edge device should be configured with different native VLANs. The native VLAN of one trunk port should not be in the list of allowed VLANs of the other trunk port to avoid loops.

Figure 3: Layer 2 Protocol Tunneling for EtherChannels

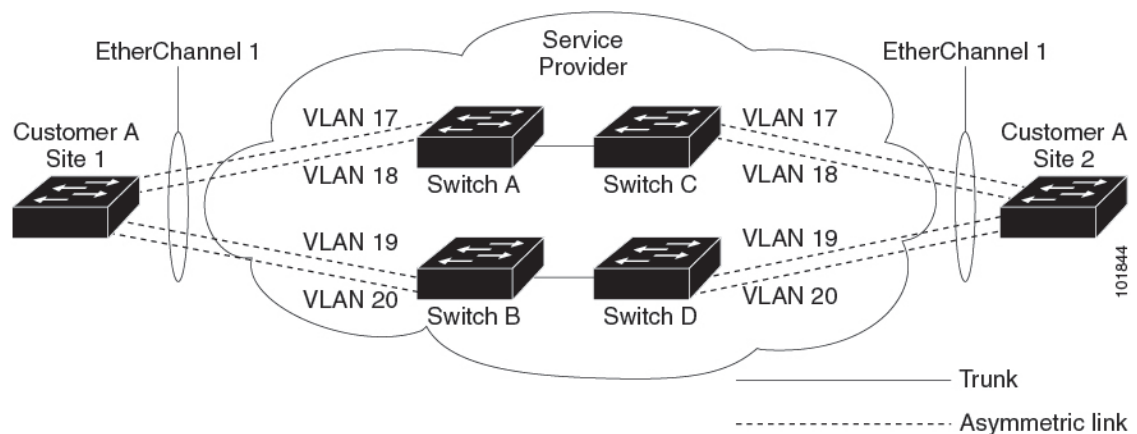

Default Layer 2 Protocol Tunneling Configuration

The following table shows the default Layer 2 protocol tunneling configuration.

Table 1: Default Layer 2 Ethernet Interface VLAN Configuration

Feature	Default Setting
Layer 2 protocol tunneling	Disabled.
Shutdown threshold	None set.
Drop threshold	None set.

How to Configure Layer 2 Protocol Tunneling

The following section provides configuration information on how to configure a layer 2 protocol tunnel:

Configuring Layer 2 Protocol Tunneling

Procedure

	Command or Action	Purpose
Step 1	enable Example: Device> enable	Enables privileged EXEC mode. Enter your password if prompted.
Step 2	configure terminal Example: Device# configure terminal	Enters global configuration mode.
Step 3	interface <i>interface-id</i> Example: Device(config)# interface gigabitethernet1/0/1	Specifies the interface that is connected to the phone, and enters interface configuration mode.
Step 4	Use one of the following: • switchport mode dot1q-tunnel Example: Device(config-if)# switchport mode dot1q-tunnel	Configures the interface as an IEEE 802.1Q tunnel port or a trunk port.
Step 5	l2protocol-tunnel [cdp lldp point-to-point stp vtp] Example:	Enables protocol tunneling for the desired protocol. If no keyword is entered, tunneling is enabled for all four Layer 2 protocols.

	Command or Action	Purpose
	<pre>Device(config-if)# l2protocol-tunnel cdp</pre>	<p>Note Use the no l2protocol-tunnel [cdp lldp point-to-point stp vtp] interface configuration command to disable protocol tunneling for one of the Layer 2 protocols or for all three.</p>
Step 6	<p>l2protocol-tunnel shutdown-threshold [packet_second_rate_value cdp lldp point-to-point stp vtp]</p> <p>Example:</p> <pre>Device(config-if)# l2protocol-tunnel shutdown-threshold 100 cdp</pre>	<p>(Optional) Configures the threshold for packets-per-second that are accepted for encapsulation. The interface is disabled if the configured threshold is exceeded. If no protocol option is specified, the threshold applies to each of the tunneled Layer 2 protocol types. The range is 1 to 4096. The default is to have no threshold configured.</p> <p>Note If you also set a drop threshold on this interface, the shutdown-threshold value must be greater than or equal to the drop-threshold value.</p> <p>Note Use the no l2protocol-tunnel shutdown-threshold [packet_second_rate_value cdp lldp point-to-point stp vtp] and the no l2protocol-tunnel drop-threshold [packet_second_rate_value cdp lldp point-to-point stp vtp] commands to return the shutdown and drop thresholds to the default settings.</p>
Step 7	<p>l2protocol-tunnel drop-threshold [packet_second_rate_value cdp lldp point-to-point stp vtp]</p> <p>Example:</p> <pre>Device(config-if)# l2protocol-tunnel drop-threshold 100 cdp</pre>	<p>(Optional) Configures the threshold for packets-per-second that are accepted for encapsulation. The interface drops packets if the configured threshold is exceeded. If no protocol option is specified, the threshold applies to each of the tunneled Layer 2 protocol types. The range is 1 to 4096. The default is to have no threshold configured.</p> <p>Note If you also set a shutdown threshold on this interface, the drop-threshold value must be less than or equal to the shutdown-threshold value.</p>

	Command or Action	Purpose
		<p>Note Use the no l2protocol-tunnel shutdown-threshold [cdp lldp] point-to-point stp vtp and the no l2protocol-tunnel drop-threshold [cdp stp vtp] commands to return the shutdown and drop thresholds to the default settings.</p>
Step 8	<p>exit</p> <p>Example:</p> <pre>Device(config-if)# exit</pre>	Returns to global configuration mode.
Step 9	<p>errdisable recovery cause l2ptguard</p> <p>Example:</p> <pre>Device(config)# errdisable recovery cause l2ptguard</pre>	(Optional) Configures the recovery mechanism from a Layer 2 maximum-rate error so that the interface is reenabled and can try again. Errdisable recovery is disabled by default; when enabled, the default time interval is 300 seconds.
Step 10	<p>spanning-tree bpdupfilter enable</p> <p>Example:</p> <pre>Device(config)# spanning-tree bpdupfilter enable</pre>	<p>Inserts a BPDU filter for spanning tree.</p> <p>Note While configuring Layer 2 Protocol Tunneling on a trunk port, you must enable a BPDU filter for spanning tree.</p>
Step 11	<p>end</p> <p>Example:</p> <pre>Device(config)# end</pre>	Returns to privileged EXEC mode.
Step 12	<p>show l2protocol</p> <p>Example:</p> <pre>Device# show l2protocol</pre>	Displays the Layer 2 tunnel ports on the device, including the protocols configured, the thresholds, and the counters.
Step 13	<p>copy running-config startup-config</p> <p>Example:</p> <pre>Device# copy running-config startup-config</pre>	(Optional) Saves your entries in the configuration file.

How to Configure Layer 2 Protocol Tunneling for EtherChannels

For EtherChannels, you need to configure both the SP (service-provider) edge devices and the customer devices for Layer 2 protocol tunneling. The following sections provide configuration information on how to configure the SP edge device and how to configure the customer device:

Configuring the SP Edge Switch

Procedure

	Command or Action	Purpose
Step 1	enable Example: Device> enable	Enables privileged EXEC mode. Enter your password if prompted.
Step 2	configure terminal Example: Device# configure terminal	Enters global configuration mode.
Step 3	interface <i>interface-id</i> Example: Device (config)# interface gigabitethernet1/0/1	Specifies the interface that is connected to the phone, and enters interface configuration mode.
Step 4	switchport trunk native vlan <i>vlan-id</i> Example: Device (config-if)# switchport trunk native vlan 2	Configures the native VLAN. Note While configuring Layer 2 Protocol Tunneling for EtherChannels on trunk ports, you must configure different native VLANs on both trunk ports on the SP edge device.
Step 5	switchport trunk allowed vlan <i>vlan-id list</i> Example: Device (config-if)# switchport trunk allowed vlan 1,2,4-3003,3005-4094	Specifies the list of allowed VLANs. Note While configuring Layer 2 Protocol Tunneling for EtherChannels on trunk ports, you must ensure that the native VLAN of one trunk port of the SP edge device should not be in the list of allowed VLANs of the other trunk port to avoid loops.
Step 6	Use one of the following: <ul style="list-style-type: none"> • switchport mode dot1q-tunnel • switchport mode trunk Example: Device (config-if)# switchport mode dot1q-tunnel or Device (config-if)# switchport mode trunk	Configures the interface as an IEEE 802.1Q tunnel port or as a trunk port.

	Command or Action	Purpose
Step 7	<p>l2protocol-tunnel point-to-point [pagp lacp udld]</p> <p>Example:</p> <pre>Device(config-if)# l2protocol-tunnel point-to-point pagp</pre>	<p>(Optional) Enables point-to-point protocol tunneling for the desired protocol. If no keyword is entered, tunneling is enabled for all three protocols.</p> <p>Note To avoid a network failure, make sure that the network is a point-to-point topology before you enable tunneling for PAgP, LACP, or UDLD packets.</p> <p>Note Use the no l2protocol-tunnel [point-to-point [pagp lacp udld]] interface configuration command to disable point-to-point protocol tunneling for one of the Layer 2 protocols or for all three.</p>
Step 8	<p>l2protocol-tunnel shutdown-threshold [point-to-point [pagp lacp udld]] <i>value</i></p> <p>Example:</p> <pre>Device(config-if)# l2protocol-tunnel shutdown-threshold point-to-point pagp 100</pre>	<p>(Optional) Configures the threshold for packets-per-second that are accepted for encapsulation. The interface is disabled if the configured threshold is exceeded. If no protocol option is specified, the threshold applies to each of the tunneled Layer 2 protocol types. The range is 1 to 4096. The default is to have no threshold configured.</p> <p>Note If you also set a drop threshold on this interface, the shutdown-threshold value must be greater than or equal to the drop-threshold value.</p> <p>Note Use the no l2protocol-tunnel shutdown-threshold [point-to-point [pagp lacp udld]] and the no l2protocol-tunnel drop-threshold [[point-to-point [pagp lacp udld]] commands to return the shutdown and drop thresholds to the default settings.</p>
Step 9	<p>l2protocol-tunnel drop-threshold [point-to-point [pagp lacp udld]] <i>value</i></p> <p>Example:</p> <pre>Device(config-if)# l2protocol-tunnel drop-threshold point-to-point pagp 500</pre>	<p>(Optional) Configures the threshold for packets-per-second that are accepted for encapsulation. The interface drops packets if the configured threshold is exceeded. If no protocol option is specified, the threshold applies to each of the tunneled Layer 2</p>

	Command or Action	Purpose
		<p>protocol types. The range is 1 to 4096. The default is to have no threshold configured.</p> <p>Note If you also set a shutdown threshold on this interface, the drop-threshold value must be less than or equal to the shutdown-threshold value.</p>
Step 10	<p>no cdp enable</p> <p>Example:</p> <pre>Device(config-if)# no cdp enable</pre>	Disables CDP on the interface.
Step 11	<p>spanning-tree bpdud filter enable</p> <p>Example:</p> <pre>Device(config-if)# spanning-tree bpdud filter enable</pre>	Enables BPDU filtering on the interface.
Step 12	<p>exit</p> <p>Example:</p> <pre>Device(config-if)# exit</pre>	Returns to global configuration mode.
Step 13	<p>errdisable recovery cause l2ptguard</p> <p>Example:</p> <pre>Device(config)# errdisable recovery cause l2ptguard</pre>	<p>(Optional) Configures the recovery mechanism from a Layer 2 maximum-rate error so that the interface is reenabled and can try again. Errdisable recovery is disabled by default; when enabled, the default time interval is 300 seconds.</p>
Step 14	<p>end</p> <p>Example:</p> <pre>Device(config)# end</pre>	Returns to privileged EXEC mode.
Step 15	<p>show l2protocol</p> <p>Example:</p> <pre>Device# show l2protocol</pre>	Displays the Layer 2 tunnel ports on the device, including the protocols configured, the thresholds, and the counters.
Step 16	<p>copy running-config startup-config</p> <p>Example:</p> <pre>Device# copy running-config startup-config</pre>	(Optional) Saves your entries in the configuration file.

Configuring the Customer Device

Before you begin

For EtherChannels, you need to configure both the SP edge device and the customer device for Layer 2 protocol tunneling.

Procedure

	Command or Action	Purpose
Step 1	enable Example: Device> enable	Enables privileged EXEC mode. Enter your password if prompted.
Step 2	configure terminal Example: Device# configure terminal	Enters global configuration mode.
Step 3	interface <i>interface-id</i> Example: Device(config)# interface gigabitethernet1/0/1	Specifies the interface that is connected to the phone, and enters interface configuration mode.
Step 4	switchport trunk encapsulation dot1q Example: Device(config-if)# switchport trunk encapsulation dot1q	Sets the trunking encapsulation format to IEEE 802.1Q.
Step 5	switchport mode trunk Example: Device(config-if)# switchport mode trunk	Enables trunking on the interface.
Step 6	udld port Example: Device(config-if)# udld port	Enables UDLD in normal mode on the interface.
Step 7	channel-group <i>channel-group-number</i> mode desirable Example: Device(config-if)# channel-group 25 mode desirable	Assigns the interface to a channel group, and specifies desirable for the PAgP mode.
Step 8	exit Example: Device(config-if)# exit	Returns to global configuration mode.

	Command or Action	Purpose
Step 9	interface port-channel port-channel <i>number</i> Example: Device(config)# interface port-channel port-channel 25	Enters port-channel interface mode.
Step 10	shutdown Example: Device(config)# shutdown	Shuts down the interface.
Step 11	no shutdown Example: Device(config)# no shutdown	Enables the interface.
Step 12	end Example: Device(config)# end	Returns to privileged EXEC mode.
Step 13	show l2protocol Example: Device# show l2protocol	Displays the Layer 2 tunnel ports on the device, including the protocols configured, the thresholds, and the counters.
Step 14	copy running-config startup-config Example: Device# copy running-config startup-config	(Optional) Saves your entries in the configuration file. Note Use the no switchport mode trunk , the no udld enable , and the no channel group channel-group-number mode desirable interface configuration commands to return the interface to the default settings.

Configuration Examples for Layer 2 Protocol Tunneling

The following sections provide various configuration examples for layer 2 protocol tunneling:

Example: Configuring Layer 2 Protocol Tunneling

The following example shows how to configure Layer 2 protocol tunneling for Cisco Discovery Protocol, STP, and VTP and to verify the configuration.

```
Device(config)# interface gigabitethernet1/0/11
Device(config-if)# l2protocol-tunnel cdp
Device(config-if)# l2protocol-tunnel stp
```

```

Device(config-if)# l2protocol-tunnel vtp
Device(config-if)# l2protocol-tunnel shutdown-threshold 1500
Device(config-if)# l2protocol-tunnel drop-threshold 1000
Device(config-if)# exit

Device(config)# end
Device# show l2protocol

Port Protocol Shutdown Drop Encapsulation Decapsulation Drop
Threshold Threshold Counter Counter Counter
-----
Gi0/11 cdp 1500 1000 2288 2282 0
stp 1500 1000 116 13 0
vtp 1500 1000 3 67 0
pagp ---- ---- 0 0 0
lACP ---- ---- 0 0 0
udld ---- ---- 0 0 0

```

Examples: Configuring the SP Edge and Customer Switches

This example shows how to configure the SP edge switch 1 and edge switch 2. VLANs 17, 18, 19, and 20 are the access VLANs, Fast Ethernet interfaces 1 and 2 are point-to-point tunnel ports with PAGP and UDLD enabled, the drop threshold is 1000, and Fast Ethernet interface 3 is a trunk port.

SP edge switch 1 configuration:

```

Device(config)# interface gigabitethernet1/0/1
Device(config-if)# switchport access vlan 17
Device(config-if)# switchport mode dot1q-tunnel
Device(config-if)# l2protocol-tunnel point-to-point pagp
Device(config-if)# l2protocol-tunnel point-to-point udld
Device(config-if)# l2protocol-tunnel drop-threshold point-to-point pagp 1000
Device(config-if)# exit
Device(config)# interface gigabitethernet1/0/2
Device(config-if)# switchport access vlan 18
Device(config-if)# switchport mode dot1q-tunnel
Device(config-if)# l2protocol-tunnel point-to-point pagp
Device(config-if)# l2protocol-tunnel point-to-point udld
Device(config-if)# l2protocol-tunnel drop-threshold point-to-point pagp 1000
Device(config-if)# exit
Device(config)# interface gigabitethernet1/0/3
Device(config-if)# switchport trunk encapsulation isl
Device(config-if)# switchport mode trunk

```

SP edge switch 2 configuration:

```

Device(config)# interface gigabitethernet1/0/1
Device(config-if)# switchport access vlan 19
Device(config-if)# switchport mode dot1q-tunnel
Device(config-if)# l2protocol-tunnel point-to-point pagp
Device(config-if)# l2protocol-tunnel point-to-point udld
Device(config-if)# l2protocol-tunnel drop-threshold point-to-point pagp 1000
Device(config-if)# exit
Device(config)# interface gigabitethernet1/0/2
Device(config-if)# switchport access vlan 20
Device(config-if)# switchport mode dot1q-tunnel
Device(config-if)# l2protocol-tunnel point-to-point pagp
Device(config-if)# l2protocol-tunnel point-to-point udld

```

```

Device(config-if) # l2protocol-tunnel drop-threshold point-to-point pagp 1000
Device(config-if) # exit
Device(config) # interface gigabitethernet1/0/3
Device(config-if) # switchport trunk encapsulation isl
Device(config-if) # switchport mode trunk

```

This example shows how to configure the customer switch at Site 1. Fast Ethernet interfaces 1, 2, 3, and 4 are set for IEEE 802.1Q trunking, UDLD is enabled, EtherChannel group 1 is enabled, and the port channel is shut down and then enabled to activate the EtherChannel configuration.

```

Device(config) # interface gigabitethernet1/0/1
Device(config-if) # switchport trunk encapsulation dot1q
Device(config-if) # switchport mode trunk
Device(config-if) # udld enable
Device(config-if) # channel-group 1 mode desirable
Device(config-if) # exit
Device(config) # interface gigabitethernet1/0/2
Device(config-if) # switchport trunk encapsulation dot1q
Device(config-if) # switchport mode trunk
Device(config-if) # udld enable
Device(config-if) # channel-group 1 mode desirable
Device(config-if) # exit
Device(config) # interface gigabitethernet1/0/3
Device(config-if) # switchport trunk encapsulation dot1q
Device(config-if) # switchport mode trunk
Device(config-if) # udld enable
Device(config-if) # channel-group 1 mode desirable
Device(config-if) # exit
Device(config) # interface gigabitethernet1/0/4
Device(config-if) # switchport trunk encapsulation dot1q
Device(config-if) # switchport mode trunk
Device(config-if) # udld enable
Device(config-if) # channel-group 1 mode desirable
Device(config-if) # exit
Device(config) # interface port-channel 1
Device(config-if) # shutdown
Device(config-if) # no shutdown
Device(config-if) # exit

```

Monitoring Tunneling Status

The following table describes the commands used to monitor tunneling status.

Table 2: Commands for Monitoring Tunneling

Command	Purpose
clear l2protocol-tunnel counters	Clears the protocol counters on Layer 2 protocol tunneling ports.
show dot1q-tunnel	Displays IEEE 802.1Q tunnel ports on the device.
show dot1q-tunnel interface <i>interface-id</i>	Verifies if a specific interface is a tunnel port.

Command	Purpose
show l2protocol-tunnel	Displays information about Layer 2 protocol tunneling ports.
show errdisable recovery	Verifies if the recovery timer from a Layer 2 protocol-tunnel error disable state is enabled.
show l2protocol-tunnel interface <i>interface-id</i>	Displays information about a specific Layer 2 protocol tunneling port.
show l2protocol-tunnel summary	Displays only Layer 2 protocol summary information.
show vlan dot1q tag native	Displays the status of native VLAN tagging on the device.

Feature History for Layer 2 Protocol Tunneling

This table provides release and related information for features explained in this module.

These features are available on all releases subsequent to the one they were introduced in, unless noted otherwise.

Release	Feature	Feature Information
Cisco IOS XE Gibraltar 16.12.1	Layer 2 Protocol Tunneling	Layer 2 protocols allow you to scale topologies to include all remote sites and local sites.

Use Cisco Feature Navigator to find information about platform and software image support. To access Cisco Feature Navigator, go to <http://www.cisco.com/go/cfn>.

