



Configuring Unicast Reverse Path Forwarding

- [Prerequisites for Unicast Reverse Path Forwarding, on page 1](#)
- [Restrictions for Unicast Reverse Path Forwarding, on page 1](#)
- [Information About Unicast Reverse Path Forwarding, on page 2](#)
- [How to Configure Unicast Reverse Path Forwarding, on page 7](#)
- [Monitoring and Maintaining Unicast Reverse Path Forwarding, on page 9](#)
- [Example: Configuring Unicast RPF, on page 10](#)
- [Feature History for Unicast Reverse Path Forwarding, on page 11](#)

Prerequisites for Unicast Reverse Path Forwarding

- Unicast Reverse Path Forwarding (RPF) requires Cisco Express Forwarding to function properly on a device.
- Prior to configuring Unicast RPF, you must configure the following access control lists (ACLs):
 - Configure standard or extended ACL to mitigate the transmission of invalid IP addresses (by performing egress filtering). Configuring standard or extended ACLs permit only valid source addresses to leave your network and enter the Internet.
 - Configure standard or extended ACL entries to drop (deny) packets that have invalid source IP addresses (by performing ingress filtering). Invalid source IP addresses include the following types:
 - Broadcast addresses (including multicast addresses)
 - Loopback addresses
 - Private addresses (RFC 1918, *Address Allocation for Private Internets*)
 - Reserved addresses
 - Source addresses that fall outside the range of valid addresses that are associated with the protected network

Restrictions for Unicast Reverse Path Forwarding

The following basic restrictions apply to multihomed clients:

- Clients should not be multihomed on the same device because multihoming defeats the purpose of creating a redundant service for a client.
- Ensure that packets that flow up the link (out to the Internet) match the route advertised out of the link. Otherwise, Unicast RPF filters these packets as malformed packets.

Information About Unicast Reverse Path Forwarding

The Unicast Reverse Path Forwarding feature helps to mitigate problems that are caused by the introduction of malformed or forged (spoofed) IP source addresses into a network by discarding IP packets that lack a verifiable IP source address. For example, a number of common types of denial-of-service (DoS) attacks, including Smurf and Tribal Flood Network (TFN), can take advantage of forged or rapidly changing source IP addresses to allow attackers to thwart efforts to locate or filter the attacks. For Internet service providers (ISPs) that provide public access, Unicast RPF deflects such attacks by forwarding only packets that have source addresses that are valid and consistent with the IP routing table. This action protects the network of the ISP, its customer, and the rest of the Internet.



Note Enabling IPv4 unicast RPF also enables IPv6 unicast RPF. This is applicable only for the .



Note Do not configure unicast RPF if the switch is in a mixed hardware stack combining more than one switch type.

Unicast RPF Operation

When Unicast RPF is enabled on an interface of a device, the device examines all packets received as input on that interface to ensure that the source address and source interface information appears in the routing table and matches the interface on which packets are received. This ability to “look backwards” is available only when Cisco Express Forwarding is enabled on a device because the lookup relies on the presence of a Forwarding Information Base (FIB). Cisco Express Forwarding generates a FIB as part of its operation.



Note Unicast RPF is an input function and is applied only on the input interface of a device at the upstream end of a connection.

Unicast RPF does a reverse lookup in the Cisco Express Forwarding table to check if any packet received at the interface of a device arrives on the best return path (or return route) to the source of the packet. If the packet was received from one of the best reverse path routes, the packet is forwarded as normal. No reverse path route on the interface from which the packet was received can mean that the source address was modified. If Unicast RPF cannot find a reverse path for the packet, the packet is dropped or forwarded, depending on whether an access control list (ACL) is specified by using the **ip verify unicast reverse-path** command in interface configuration mode.



Note With Unicast RPF, all equal-cost “best” return paths are considered valid. Unicast RPF supports multiple return paths, provided that each path is equal to the others in terms of the routing cost (such as number of hops, weights, and so on) and the route is available in the FIB. Unicast RPF also functions where Enhanced Interior Gateway Routing Protocol (EIGRP) variants are used.

Before forwarding a packet that is received at the interface on which Unicast RPF and ACLs have been configured, Unicast RPF does the following checks:

1. If input ACLs are configured on the inbound interface.
2. If the packet has arrived on the best return path to the source by doing a reverse lookup in the FIB table.
3. Does a lookup of the Cisco Express Forwarding table for packet forwarding.
4. Checks output ACLs on the outbound interface.
5. Forwards the packet.

Per-Interface Statistics

Each time a packet is dropped or forwarded at an interface, that information is counted two ways: globally on the device and at each interface where you have applied Unicast RPF. Global statistics on dropped packets provide information about potential attacks on the network; however, these global statistics do not help to specify which interface is the source of the attack.

Per-interface statistics allow network administrators to track two types of information about malformed packets: Unicast RPF drops and Unicast RPF suppressed drops. Statistics on the number of packets that Unicast RPF drops help to identify the interface that is the entry point of the attack. The Unicast RPF drop count tracks the number of drops at the interface. The Unicast RPF suppressed drop count tracks the number of packets that failed the Unicast RPF check but were forwarded because of the permit permission set up in the ACL. Using the drop count and suppressed drop count statistics, a network administrator can take steps to isolate the attack at a specific interface.

The figure below illustrates how Unicast RPF and CEF work together to validate IP source addresses by verifying packet return paths. In this example, a customer has sent a packet having a source address of 192.168.1.1 from interface FDDI 2/0/0. Unicast RPF checks the FIB to see if 192.168.1.1 has a path to FDDI 2/0/0. If there is a matching path, the packet is forwarded. If there is no matching path, the packet is dropped.

Figure 1: Unicast RPF Validating IP Source Addresses

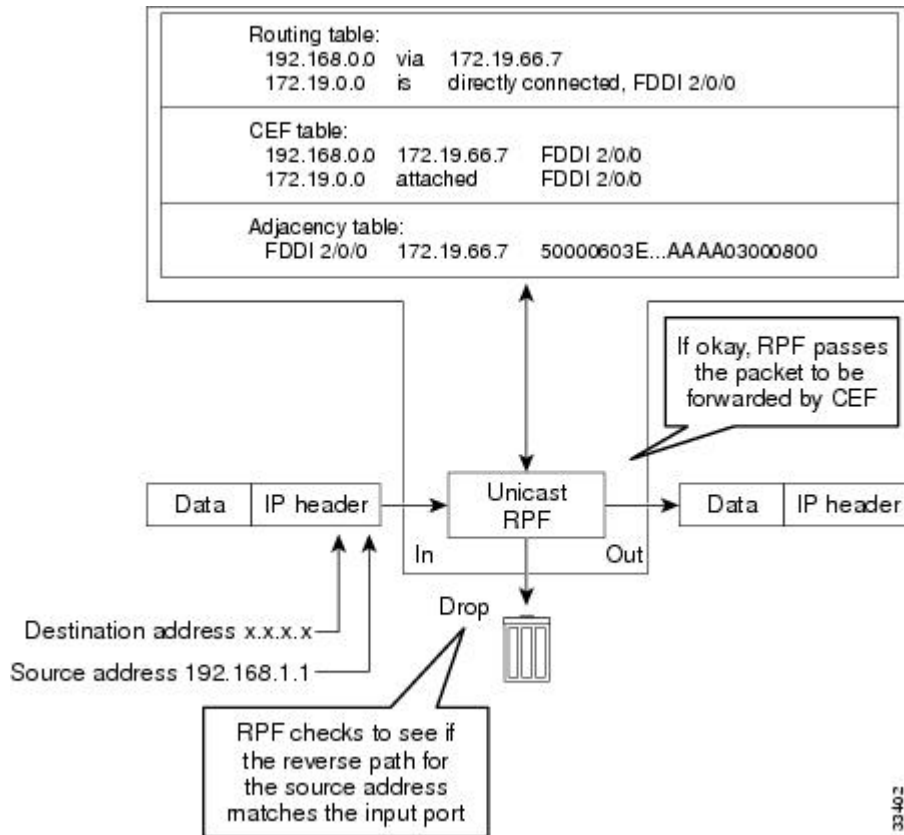

The figure below illustrates how Unicast RPF drops packets that fail validation. In this example, a customer has sent a packet having a source address of 209.165.200.225, which is received at interface FDDI 2/0/0. Unicast RPF checks the FIB to see if 209.165.200.225 has a return path to FDDI 2/0/0. If there is a matching path, the packet is forwarded. In this case, there is no reverse entry in the routing table that routes the customer packet back to source address 209.165.200.225 on interface FDDI 2/0/0, and so the packet is dropped.

Figure 2: Unicast RPF Dropping Packets That Fail Verification

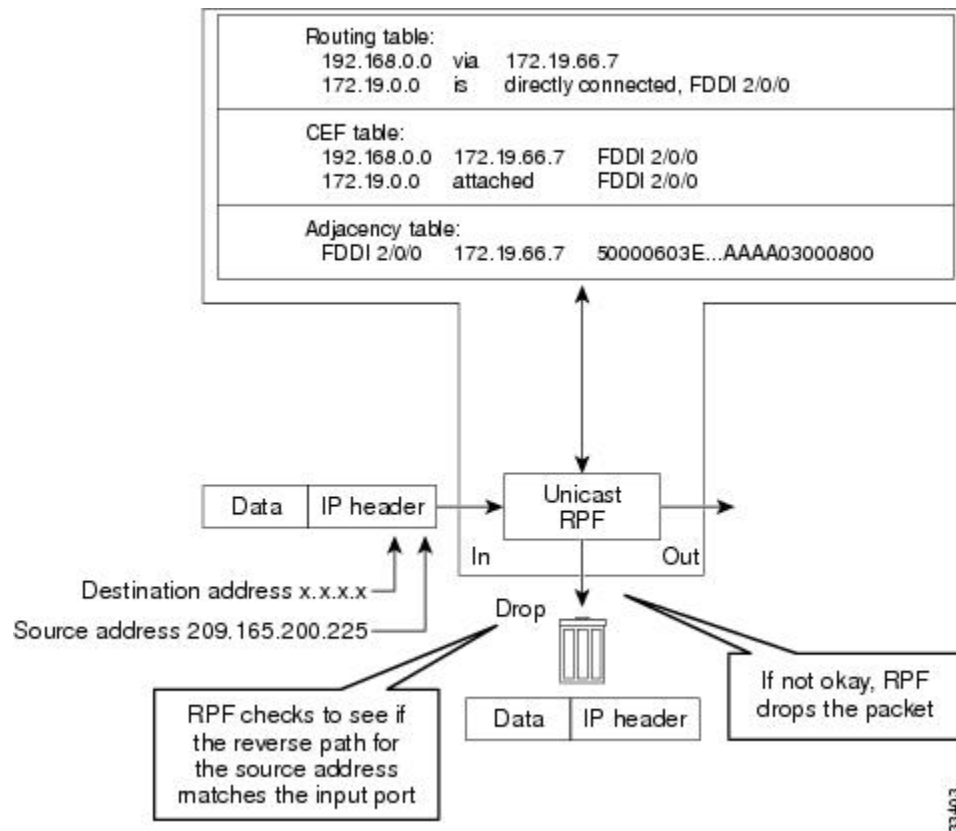

Implementation of Unicast Reverse Path Forwarding Notification

Unicast RPF is a security feature that verifies the validity of the source IP of an incoming packet. When a packet arrives at an interface and its source IP is unknown in the routing table or is a known bad source address, Unicast RPF drops the packet. IP verification of the source is done to prevent the DoS attacks by detecting problems with the incoming packets on an interface. However, deploying Unicast RPF without some automated monitoring capability is a challenge.

The CISCO-IP-URPF-MIB lets you specify a Unicast RPF drop-rate threshold on interfaces of a managed device that will send an SNMP notification when the threshold is exceeded. The MIB includes objects for specifying global and per-interface drop counts and drop rates and a method to generate SNMP traps when the drop rate exceeds a configurable per-interface threshold.

Although you can configure some parameters globally, you must configure the CISCO-IP-URPF-MIB on individual interfaces.

Security Policy and Unicast RPF

When determining how to deploy Unicast Reverse Path Forwarding (RPF), consider the following points:

- Apply Unicast RPF at the downstream interface, away from the larger portion of the network, preferably at the edges of your network. The further you apply Unicast RPF, the finer the granularity you have in mitigating address spoofing and in identifying sources of spoofed addresses. For example, applying Unicast RPF on an aggregation device helps to mitigate attacks from many downstream networks or

clients and is simple to administer, but Unicast RPF does not help in identifying the source of the attack. Applying Unicast RPF at the network access server helps to limit the scope of the attack and trace the source of the attack. However, deploying Unicast RPF across many sites adds to the administration cost of operating a network.

- When you deploy Unicast RPF on many entities on a network (for example, across the Internet, intranet, and extranet resources), you have better chances of mitigating large-scale network disruptions throughout the Internet community, and of tracing the source of an attack.
- Unicast RPF does not inspect IP packets that are encapsulated in tunnels, such as the generic routing encapsulation (GRE), Layer 2 Tunneling Protocol (L2TP), or Point-to-Point Tunneling Protocol (PPTP). Configure Unicast RPF on a home gateway so that Unicast RPF processes network traffic only after tunneling and encryption layers are stripped off from the packets.

Ingress and Egress Filtering Policy for Unicast RPF



Note Unicast RPF with access control lists (ACLs) is not supported on the

Unicast RPF can be more effective at mitigating spoofing attacks when combined with a policy of ingress and egress filtering by using ACLs.

Ingress filtering applies filters to traffic that is received at a network interface from either internal or external networks. With ingress filtering, packets that arrive from other networks or the Internet and that have a source address that matches a local network or private or broadcast addresses are dropped. For example, in ISP environments, ingress filtering can be applied to traffic that is received at a device from either a client (customer) or the Internet.

Egress filtering applies filters to the traffic that exits a network interface (the sending interface). By filtering packets on devices that connect your network to the Internet or to other networks, you can permit only packets with valid source IP addresses to leave your network.

For more information on network filtering, refer to RFC 2267, *Network Ingress Filtering: Defeating Denial of Service Attacks which employ IP Source Address Spoofing*.

Where to Use Unicast Reverse Path Forwarding

Unicast RPF can be used in any “single-homed” environment where there is essentially only one access point out of the network, which means that there is only one upstream connection to the network. Networks having one access point offer the best example of symmetric routing, which means that the interface where a packet enters the network is also the best return path to the source of the IP packet. Unicast RPF is best used at the network perimeter for Internet, intranet, or extranet environments, or in ISP environments for customer network terminations.

Routing Table Requirements

Unicast Reverse Path Forwarding (RPF) uses the routing information in Cisco Express Forwarding tables for routing traffic. The amount of routing information that must be available in Cisco Express Forwarding tables depends on the device where Unicast RPF is configured and the functions the device performs in the network. For example, in an ISP environment where a device is a leased-line aggregation device for customers, the

information about static routes that are redistributed into the Interior Gateway Protocol (IGP) or Internal Border Gateway Protocol (IBGP) (depending on which technique is used in the network) is required in the routing table. Because Unicast RPF is configured on customer interfaces, only minimal routing information is required. If a single-homed ISP configures Unicast RPF on the gateway to the Internet, the full Internet routing table information is required by Unicast RPF to help protect the ISP from external denial of service (DoS) attacks that use addresses that are not in the Internet routing table.

Where Not to Use Unicast Reverse Path Forwarding

Do not use unicast RPF on interfaces that are internal to a network. Internal interfaces are likely to have routing asymmetry (see the figure below), which means that there can be multiple routes to the source of a packet. Unicast RPF is applied only where there is a natural or configured symmetry.

For example, devices at the edge of an ISP network are more likely to have symmetrical reverse paths than devices that are in the core of an ISP network. The best forwarding path to forward packets from devices that are at the core of an ISP network may not be the best forwarding path that is selected for packets that are returned to the device.

We recommend that you do not apply Unicast RPF where there is a chance of asymmetric routing, unless you configure access control lists (ACLs) to allow the device to accept incoming packets. ACLs permit the use of Unicast RPF when packets arrive through specific, less-optimal asymmetric input paths.

The figure below illustrates how Unicast RPF can block legitimate traffic in an asymmetric routing environment.

Figure 3: Unicast RPF Blocking Legitimate Traffic in an Asymmetric Routing Environment

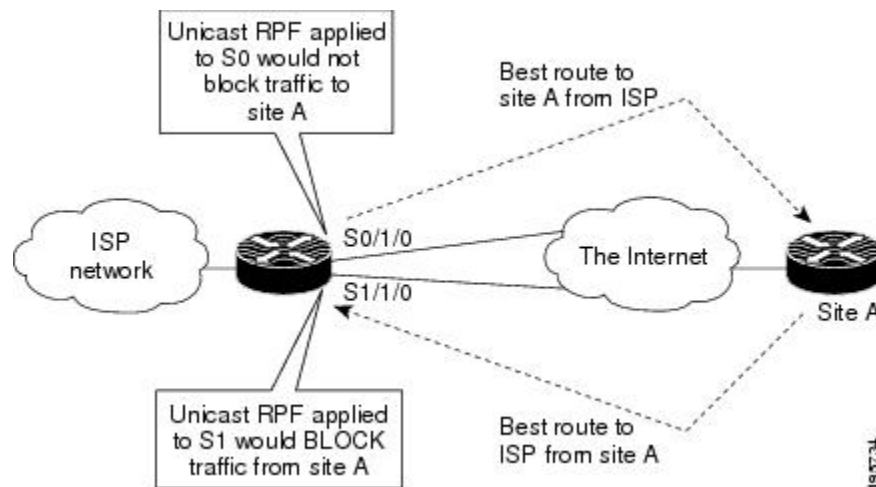

Unicast Reverse Path Forwarding with BOOTP and DHCP

Unicast RPF allows packets with 0.0.0.0 as the source IP address and 255.255.255.255 as the destination IP address to pass through a network to enable Bootstrap Protocol (BOOTP) and DHCP functions to work properly when Unicast RPF is configured.

How to Configure Unicast Reverse Path Forwarding

The following section provide configuration information about unicast reverse path forwarding.

Configuring Unicast Reverse Path Forwarding

Before you begin

To use Unicast Reverse Path Forwarding, you must configure a device for Cisco Express Forwarding switching or distributed Cisco Express Forwarding switching. If Cisco Express Forwarding is not enabled globally on a device, Unicast RPF will not work on that device. If Cisco Express Forwarding is running on a device, individual interfaces on the device can be configured with other switching modes. Unicast RPF is an input-side function that is enabled on an interface or subinterface that supports any type of encapsulation, and Unicast RPF operates on IP packets that are received by the device.

Procedure

	Command or Action	Purpose
Step 1	enable Example: Device> enable	Enables privileged EXEC mode. Enter your password if prompted.
Step 2	configure terminal Example: Device# configure terminal	Enters global configuration mode.
Step 3	ip cef distributed Example: Device(config)# ip cef distributed	Enables Cisco Express Forwarding or distributed Cisco Express Forwarding on a device.
Step 4	interface slot/subslot/port Example: Device(config)# interface GigabitEthernet 0/0	Selects the input interface on which you want to apply Unicast Reverse Path Forwarding and enters interface configuration mode. The interface that is configured is the receiving interface, which allows Unicast RPF to verify the best return path before forwarding a packet to the next destination.
Step 5	ip verify unicast reverse-path list Example: Device(config-if)# ip verify unicast reverse-path 197	Enables Unicast RPF on the interface. <ul style="list-style-type: none"> • Use the <i>list</i> argument to identify an access list. If the access list denies network access, spoofed packets are dropped at the interface. If the access list permits network access, spoofed packets are forwarded to the destination address. Forwarded packets are counted in the interface statistics. If the access list includes the logging option, information about the spoofed packets is logged to the log server. • Repeat this step for each access list that you want specify

	Command or Action	Purpose
Step 6	exit Example: Device(config-if)# exit	Exits interface configuration mode.

Troubleshooting Tips

HSRP Failure

The failure to disable Unicast RPF before disabling Cisco Express Forwarding can cause a Hot Standby Router Protocol (HSRP) failure. If you want to disable Cisco Express Forwarding on a device, you must first disable Unicast RPF.

Monitoring and Maintaining Unicast Reverse Path Forwarding

This section describes commands used to monitor and maintain unicast RPF.

Command	Purpose
Device# show ip traffic	Displays global router statistics about Unicast RPF drops and suppressed drops.
Device# show ip interface type	Displays per-interface statistics about Unicast RPF drops and suppressed drops.
Device# show access-lists	Displays the number of matches to a specific ACL.
Device(config-if)# no ip verify unicast reverse-path list	Disables Unicast RPF at the interface. Use the <i>list</i> option to disable Unicast RPF for a specific ACL at the interface.



Caution To disable CEF, you must first disable Unicast RPF. Failure to disable Unicast RPF before disabling CEF can cause HSRP failure. If you want to disable CEF on the router, you must first disable Unicast RPF.

Unicast RPF counts the number of packets dropped or suppressed because of malformed or forged source addresses. Unicast RPF counts dropped or forwarded packets that include the following global and per-interface information:

- Global Unicast RPF drops
- Per-interface Unicast RPF drops
- Per-interface Unicast RPF suppressed drops

The **show ip traffic** command shows the total number (global count) of dropped or suppressed packets for all interfaces on the router. The Unicast RPF drop count is included in the IP statistics section.

```

Device# show ip traffic

IP statistics:
  Rcvd: 1471590 total, 887368 local destination
        0 format errors, 0 checksum errors, 301274 bad hop count
        0 unknown protocol, 0 not a gateway
        0 security failures, 0 bad options, 0 with options
  Opts: 0 end, 0 nop, 0 basic security, 0 loose source route
        0 timestamp, 0 extended security, 0 record route
        0 stream ID, 0 strict source route, 0 alert, 0 other
  Frags: 0 reassembled, 0 timeouts, 0 couldn't reassemble
        0 fragmented, 0 couldn't fragment
  Bcast: 205233 received, 0 sent
  Mcast: 463292 received, 462118 sent
  Sent: 990158 generated, 282938 forwarded
  ! The second line below ("0 unicast RPF") displays Unicast RPF packet dropping
  information.
  Drop: 3 encapsulation failed, 0 unresolved, 0 no adjacency
        0 no route, 0 unicast RPF, 0 forced drop

```

A nonzero value for the count of dropped or suppressed packets can mean one of two things:

- Unicast RPF is dropping or suppressing packets that have a bad source address (normal operation).
- Unicast RPF is dropping or suppressing legitimate packets because the route is misconfigured to use Unicast RPF in environments where asymmetric routing exists; that is, where multiple paths can exist as the best return path for a source address.

The **show ip interface** command shows the total of dropped or suppressed packets at a specific interface. If Unicast RPF is configured to use a specific ACL, that ACL information is displayed along with the drop statistics.

```

Device> show ip interface ethernet0/1/1

Unicast RPF ACL 197
  1 unicast RPF drop
  1 unicast RPF suppressed drop

```

The **show access-lists** command displays the number of matches found for a specific entry in a specific access list.

```

Device> show access-lists

Extended IP access list 197
  deny ip 192.168.201.0 0.0.0.63 any log-input (1 match)
  permit ip 192.168.201.64 0.0.0.63 any log-input (1 match)
  deny ip 192.168.201.128 0.0.0.63 any log-input
  permit ip 192.168.201.192 0.0.0.63 any log-input

```

Example: Configuring Unicast RPF

```

Device# configure terminal
Device(config)# ip cef distributed
Device(config)# interface GigabitEthernet 1/0/2
Device(config-if)# description Connection to Upstream ISP
Device(config-if)# ip address 209.165.200.225 255.255.255.252
Device(config-if)# no ip redirects
Device(config-if)# no ip directed-broadcast

```

```

Device(config-if)# no ip proxy-arp
Device(config-if)# ip verify unicast reverse-path

Device# configure terminal
Device(config)# ip cef distributed
Device(config)# interface GigabitEthernet 1/0/2
Device(config-if)# description Connection to Upstream ISP
Device(config-if)# ip address 209.165.200.225 255.255.255.252
Device(config-if)# no ip redirects
Device(config-if)# no ip directed-broadcast
Device(config-if)# no ip proxy-arp
Device(config-if)# ip verify unicast source reachable-via rx

```

Feature History for Unicast Reverse Path Forwarding

This table provides release and related information for the features explained in this module.

These features are available in all the releases subsequent to the one they were introduced in, unless noted otherwise.

Release	Feature	Feature Information
Cisco IOS XE Everest 16.5.1a	Unicast Reverse Path Forwarding	Unicast RPF feature helps to mitigate problems that are caused by the introduction of malformed or forged (spoofed) IP source addresses into a network by discarding IP packets that lack a verifiable IP source address.

Use the Cisco Feature Navigator to find information about platform and software image support. To access Cisco Feature Navigator, go to <https://cfng.cisco.com/>.

