



# Installing a Power Supply Unit

- [Power Supply Modules Overview](#), on page 1
- [Finding the Power Supply Module Serial Number](#), on page 4
- [Installation Guidelines](#), on page 5
- [Installing or Replacing an AC Power Supply Module](#), on page 6

## Power Supply Modules Overview

The switch chassis has two power supply slots that operates with either one active power supply module and a redundant power supply module. You can use two AC modules or one AC module and a blank cover. The active and redundant modules must be of the same type.

All power supply modules have internal fans. All switches ship with a blank cover in the second power supply slot.

The main module is field replaceable and the redundant module is hot-swappable. The redundant power supply can also be used for extra PoE power.

Two power supply modules can be powered up from two different phases.

The following table describes the supported internal power supply modules.

**Table 1: Power Supply Module Part Numbers and Descriptions**

Part Number	Description
PWR-C5-125WAC	125 W AC power supply module
PWR-C5-600WAC	600 W AC power supply module
PWR-C5-1KWAC	1000 W AC power supply module
PWR-C6-125WAC <sup>1</sup>	125 W AC power supply module
PWR-C6-600WAC <sup>1</sup>	600 W AC power supply module
PWR-C6-1KWAC <sup>1</sup>	1000 W AC power supply module
PWR-C5-BLANK	Blank cover

1. Supported from Cisco IOS XE Gibraltar 16.11.1.

All the switches ship with a blank cover in the second power supply slot if the switches are ordered with only one power supply module.

For information about available PoE and PoE+ requirements, see these sections the [Power Supply Modules](#).

The power supply modules are autoranging units that support input voltages between 100 and 240 VAC. Each AC power supply module has a power cord for connection to an AC power outlet. The modules use an 18-AWG power cord.

The following illustrations show the power supply modules.

**Figure 1: 1000W AC Power Supply**

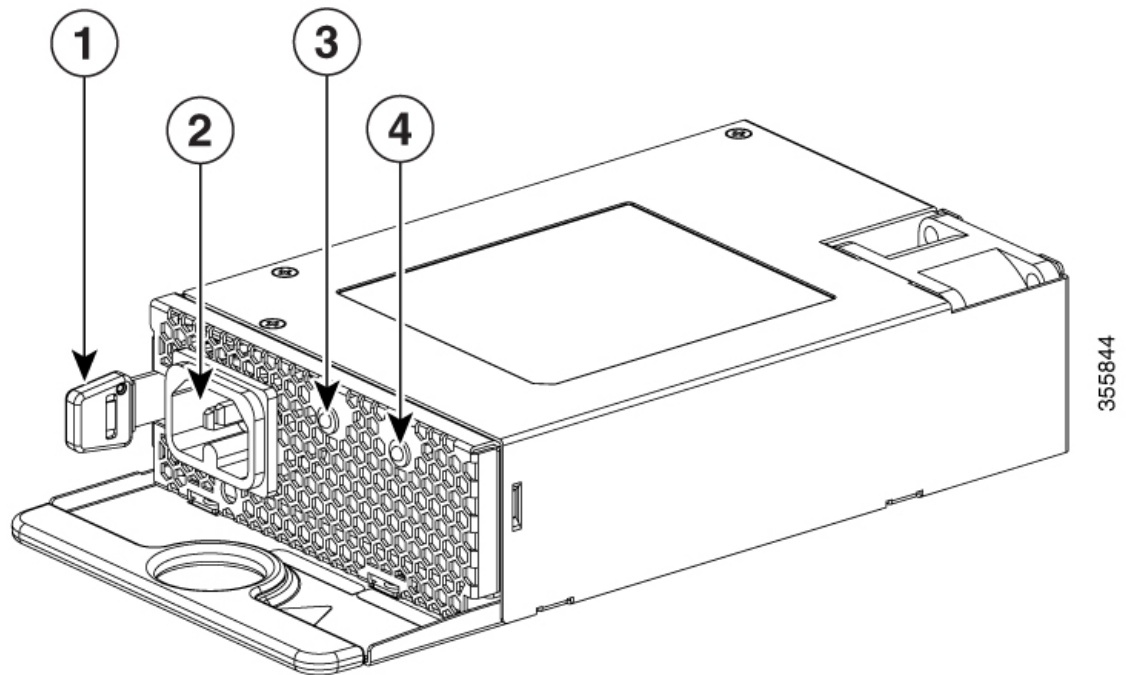
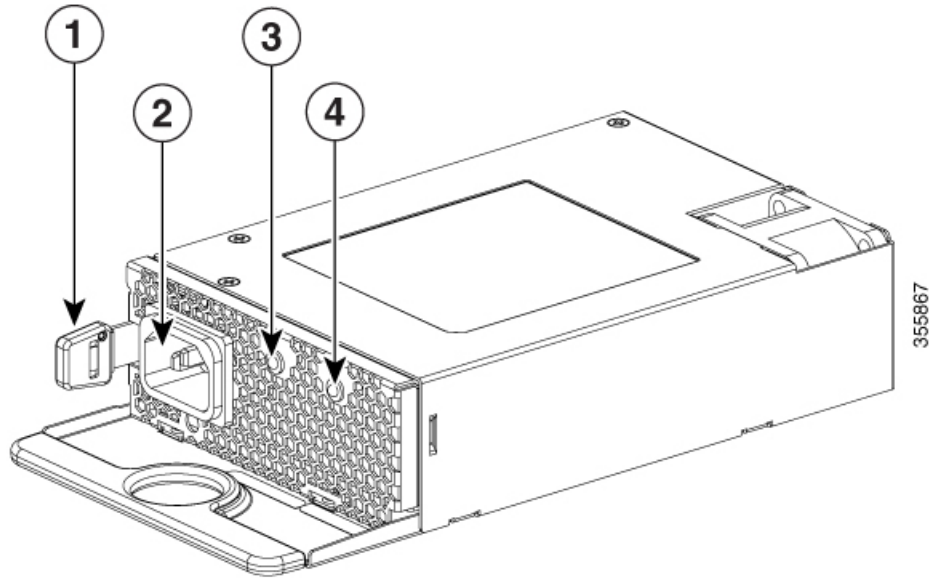

Figure 2: 125W AC Power Supply



1	Release latch	3	→] LED
2	AC power cord connector	4	←] LED

If no power supply is installed in a power supply slot, install a power supply slot cover.

Figure 3: Power Supply Slot Cover

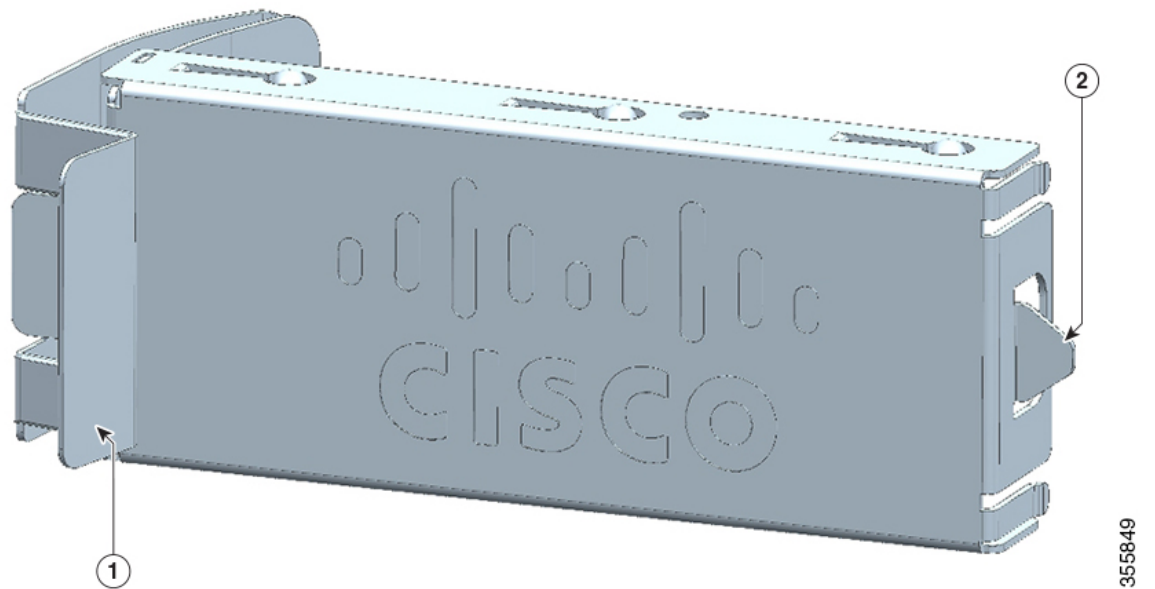

1	Release handles	2	Retainer clips
---	-----------------	---	----------------

**Table 2: Switch Power Supply Module LEDs**

→]	Description	←]	Description
Off	No AC input power.	Off	Output is disabled, or input is outside the operating range (LED is off).
Green	AC input power present.	Green	Power output to switch active.
		Red	Output has failed.

## Finding the Power Supply Module Serial Number

If you contact Cisco Technical Assistance regarding a power supply module, you need to know the serial number. See the following illustrations to find the serial number. You can also use the CLI to find out the serial number.

Figure 4: AC Power Supply Serial Number

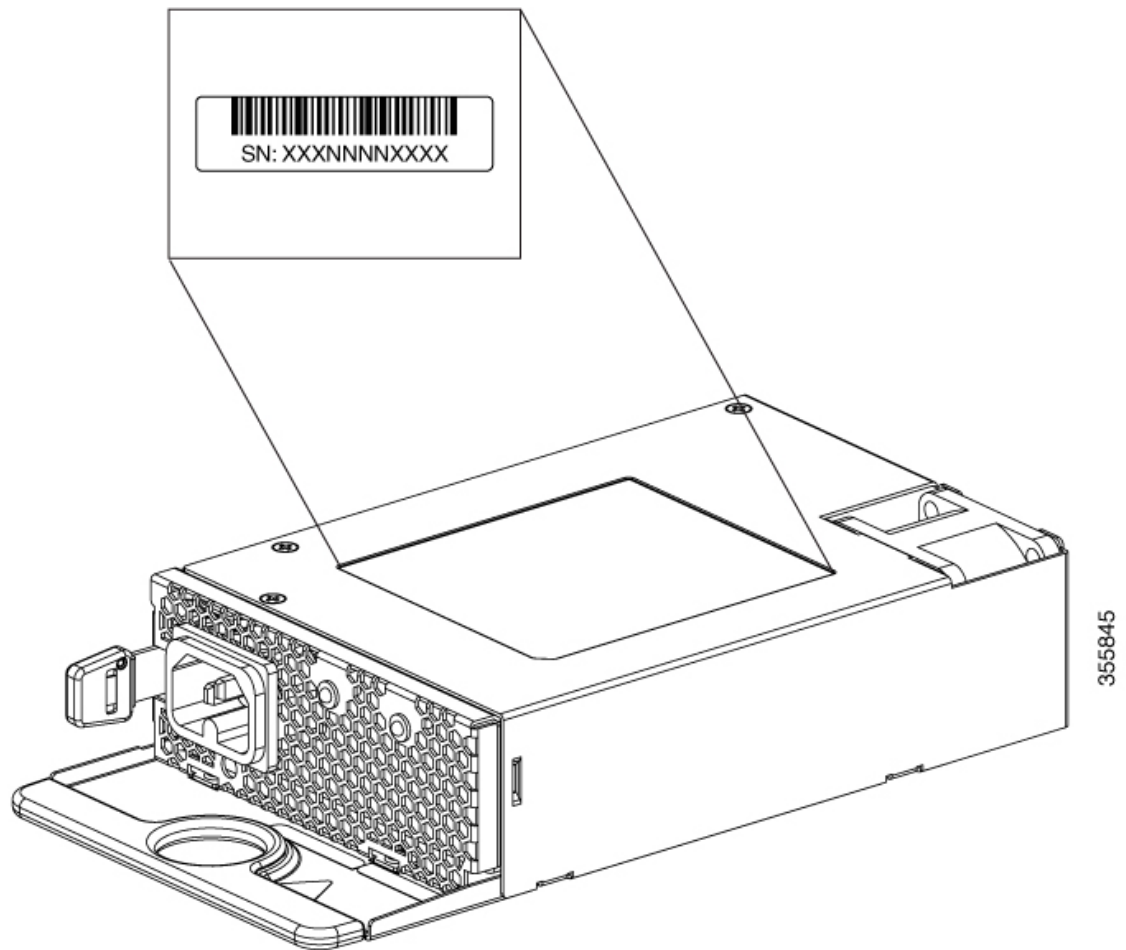

## Installation Guidelines

Observe these guidelines when removing or installing a power supply module.

- Do not force the power supply module into the slot. This can damage the pins on the switch if they are not aligned with the module.
- A power supply module that is only partially connected to the switch can disrupt the system operation.
- Remove power from the power supply module before removing or installing the module.
- The power supply module is hot-swappable. In some configurations, such as full PoE+ or power sharing mode, removing a power supply module causes powered devices to shut down until the power budget matches the input power of a single power supply module. To minimize network interruption, ensure that an active backup is in progress.

For the switch commands that display available power budget, see the software configuration guide.



---

**Caution** Do not operate the switch with one power-supply module slot empty. For proper chassis cooling, both module slots must be populated, with either a power supply or a blank module.

---



---

**Warning** This equipment must be grounded. Never defeat the ground conductor or operate the equipment in the absence of a suitably installed ground conductor. Contact the appropriate electrical inspection authority or an electrician if you are uncertain that suitable grounding is available.

Statement 1024

---



---

**Warning** Blank faceplates and cover panels serve three important functions: they prevent exposure to hazardous voltages and currents inside the chassis; they contain electromagnetic interference (EMI) that might disrupt other equipment; and they direct the flow of cooling air through the chassis. Do not operate the system unless all cards, faceplates, front covers, and rear covers are in place.

Statement 1029

---



---

**Warning** Do not reach into a vacant slot or chassis while you install or remove a module. Exposed circuitry could constitute an energy hazard.

Statement 206

---



---

**Warning** Only trained and qualified personnel should be allowed to install, replace, or service this equipment.

Statement 1030

---



---

**Warning** If a Cisco external power system is not connected to the switch, install the provided connector cover on the back of the switch.

Statement 386

---

## Installing or Replacing an AC Power Supply Module

### Procedure

---

- Step 1** Turn off the power at its source.
- Step 2** Remove the power cord from the power cord retainer.
- Step 3** Remove the power cord from the power connector.

- Step 4** Press the release latch at the right side of the power supply module inward and slide the power supply out.
- Caution** Do not leave the power-supply slot open for more than 90 seconds while the switch is operating.
- Warning** This unit might have more than one power supply connection. All connections must be removed to de-energize the unit. Statement 1028
- Step 5** Insert the new power supply into the power-supply slot, and gently push it into the slot. When correctly inserted, the power supplies (excluding the power cord retainer) are flush with the switch rear panel.

*Figure 5: Inserting the AC-Power Supply in the Switch*

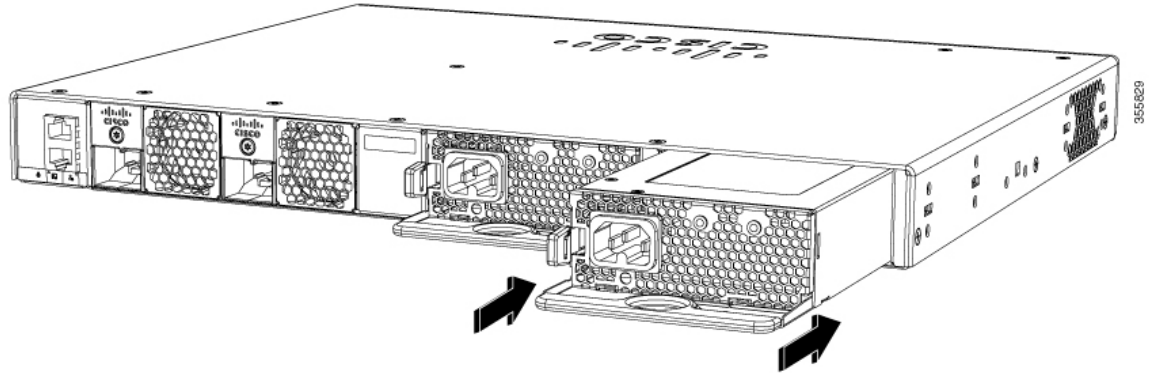

- Step 6** (Optional) Install the power cord retainer as follows:

Figure 6: AC-Power Supply with Power Cord Retainer

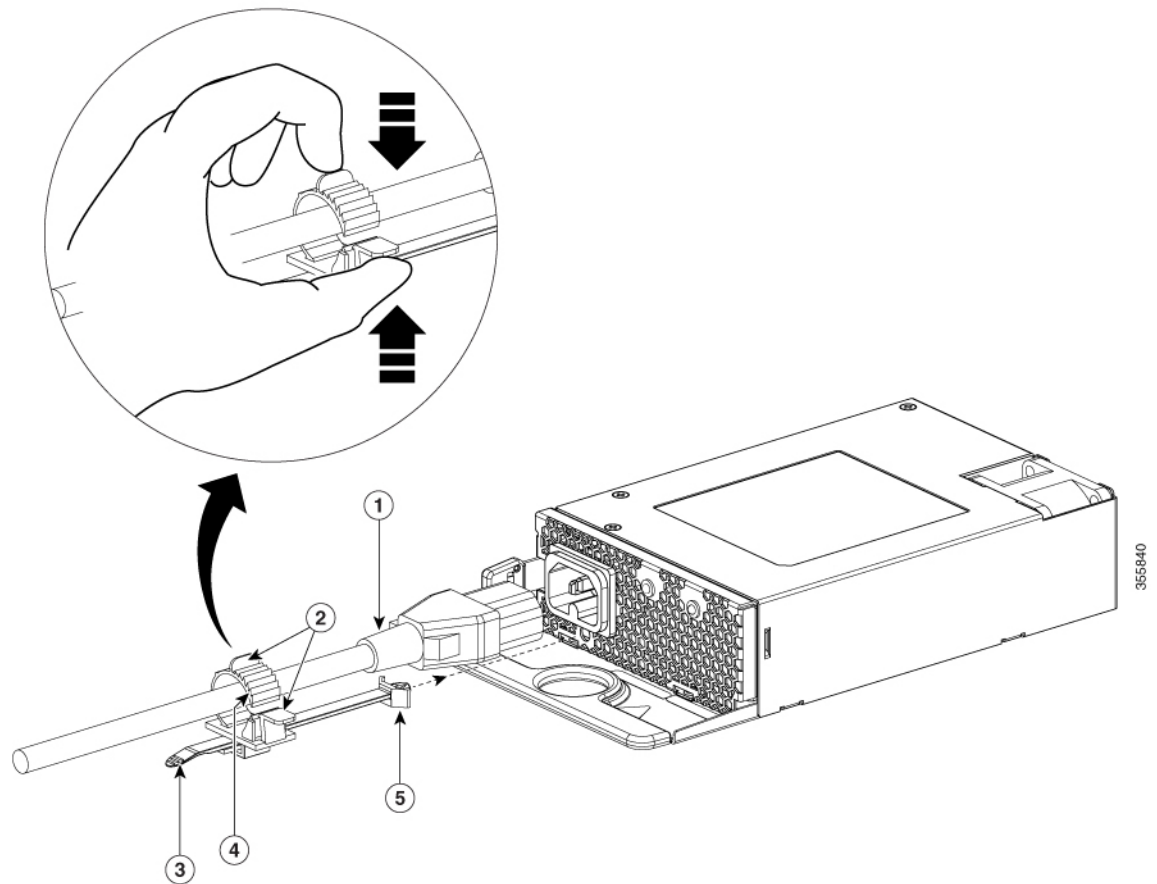

1	Power cord	4	Retainer clamp
2	Tabs on the retainer clamp	5	The strap end that is fixed to the power supply module
3	Power cord retainer strip	-	-

- Fix the strap in the power cord retainer to the power supply module, to hold the clamp in place.
- Slide the retainer clamp around the AC power cord and position the retainer closest to the power supply.

**Note** Depending on the width of the power cord, adjust the size of the retainer clamp, if required.

- Press the tabs on the retainer clamp towards each other to secure the AC power cord.

**Step 7** Connect the power cord to the power supply and to an AC power outlet. Turn on the power at the power source.

**Step 8** Confirm that the power supply →] and [← LED are green.