



## CHAPTER 5

# Configuring the Cisco IOS In Service Software Upgrade Process



**Note**

ISSU is available in Cisco IOS 12.2(31)SGA and later releases. All linecards are supported.

Operating on redundant systems, the In Service Software Upgrade (ISSU) process allows Cisco IOS software to be updated or otherwise modified while packet forwarding continues. In most networks, planned software upgrades are a significant cause of downtime. ISSU allows Cisco IOS software to be modified while packet forwarding continues. This increases network availability and reduces downtime caused by planned software upgrades. This document provides information about ISSU concepts and describes the steps taken to perform ISSU in a system.

Topics include:

- [Prerequisites to Performing ISSU, page 5-2](#)
- [•Before you perform ISSU, ensure that the system is configured for redundancy mode SSO and that the file system for both the active and the standby supervisor engines contains the new ISSU-compatible image. The current Cisco IOS version running in the system must also support ISSU., page 5-2](#)
- [About Performing ISSU, page 5-3](#)
- [How to Perform the ISSU Process, page 5-13](#)



**Note**

For complete syntax and usage information for the switch commands used in this chapter, look at the *Cisco Catalyst 4500 Series Switch Command Reference* and related publications at this location:

<http://www.cisco.com/en/US/products/hw/switches/ps4324/index.html>

If the command is not found in the Catalyst 4500 Command Reference, it will be found in the larger Cisco IOS library. Refer to the *Cisco IOS Command Reference* and related publications at this location:

<http://www.cisco.com/en/US/products/ps6350/index.html>

## Related Documents

Related Topic	Document Title
Performing ISSU	<i>Cisco IOS Software: Guide to Performing In Service Software Upgrades</i>
Information about Cisco Nonstop Forwarding	<i>Cisco Nonstop Forwarding</i> <a href="http://www.cisco.com/en/US/docs/ios/12_2s/feature/guide/fsnsf20s.html">http://www.cisco.com/en/US/docs/ios/12_2s/feature/guide/fsnsf20s.html</a>
Information about Stateful Switchover	<i>Stateful Switchover</i> <a href="http://www.cisco.com/en/US/docs/ios/12_0s/feature/guide/sso120s.html">http://www.cisco.com/en/US/docs/ios/12_0s/feature/guide/sso120s.html</a>
ISSU and MPLS clients	ISSU MPLS Clients

## Prerequisites to Performing ISSU

Before performing ISSU, you need to meet these prerequisites:

- Image type of the existing and target image must match. For example, you cannot upgrade from an IPBASE image to an ENT SERVICES image (and vice versa) without experiencing several minutes of traffic loss. Note that a similar limitation applies between crypto and non-crypto images.
- The active and the standby supervisor engines must have the same supervisor engine hardware (same model, same memory, NFL daughter card and so on).
- The new and old Cisco IOS software images must be loaded into the file systems (bootflash or compact flash) of both the active and the standby supervisor engines before you begin the ISSU process.

The old image should be available either in bootflash or compact flash and the system should have been booted from one of these locations because the boot variable should not be changed before the ISSU process unfolds.

- Stateful Switchover (SSO) must be configured and the standby supervisor engine should be in standby hot state.

These commands indicate whether SSO is enabled: **show module**, **show running-config**, **show redundancy state**.

If you do not have SSO enabled, see the *Stateful Switchover* document for further information on how to enable and configure SSO.

- Nonstop Forwarding (NSF) must be configured and working properly. If you do not have NSF enabled, see the *Cisco Nonstop Forwarding* document for further information on how to enable and configure NSF.
- Before you perform ISSU, ensure that the system is configured for redundancy mode SSO and that the file system for both the active and the standby supervisor engines contains the new ISSU-compatible image. The current Cisco IOS version running in the system must also support ISSU.

You can enter various commands on the Catalyst 4500 series switch to determine supervisor engine versioning and Cisco IOS compatibility. Alternatively, you can use the ISSU application on Cisco Feature Navigator are to determine this.

- If you enter the **no ip routing** command, ISSU will fall back from SSO to RPR mode, resulting in traffic loss.

## About Performing ISSU



### Note

---

Do not make any hardware changes while performing ISSU.

---

Before you perform ISSU, you should understand the following concepts:

- [Stateful Switchover Overview, page 5-3](#)
- [NSF Overview, page 5-5](#)
- [ISSU Process Overview, page 5-6](#)
- [Guidelines for Performing ISSU, page 5-11](#)
- [Versioning Capability in Cisco IOS Software to Support ISSU, page 5-11](#)
- [SNMP Support for ISSU, page 5-13](#)
- [Compatibility Verification Using Cisco Feature Navigator, page 5-13](#)

## Stateful Switchover Overview

Development of the SSO feature is an incremental step within an overall program to improve the availability of networks constructed with Cisco IOS switches.

In specific Cisco networking devices that support dual supervisor engines, SSO takes advantage of supervisor engine redundancy to increase network availability. SSO achieves this by establishing one of the supervisor engines as the active processor while the other supervisor engine is designated as the standby processor. Following an initial synchronization between the two supervisor engines, SSO dynamically synchronizes supervisor engine state information between them in real-time.

A switchover from the active to the standby processor occurs when the active supervisor engine fails or is removed from the networking device.

Cisco NSF is used with SSO. Cisco NSF allows the forwarding of data packets to continue along known routes while the routing protocol information is being restored following a switchover. With Cisco NSF, peer networking devices do not experience routing flaps, which reduce loss of service outages for customers.

[Figure 5-1](#) illustrates how SSO is typically deployed in service provider networks. In this example, Cisco NSF with SSO is enabled at the access layer (edge) of the service provider network. A fault at this point could result in loss of service for enterprise customers requiring access to the service provider network.

For Cisco NSF protocols that require neighboring devices to participate in Cisco NSF, Cisco NSF-aware software images must be installed on those neighboring distribution layer devices. Depending on your objectives, you may decide to deploy Cisco NSF and SSO features at the core layer of your network. Doing this can help reduce the time to restore network capacity and service for certain failures, which leads to additional availability.

Figure 5-1 Cisco NSF with SSO Network Deployment: Service Provider Networks

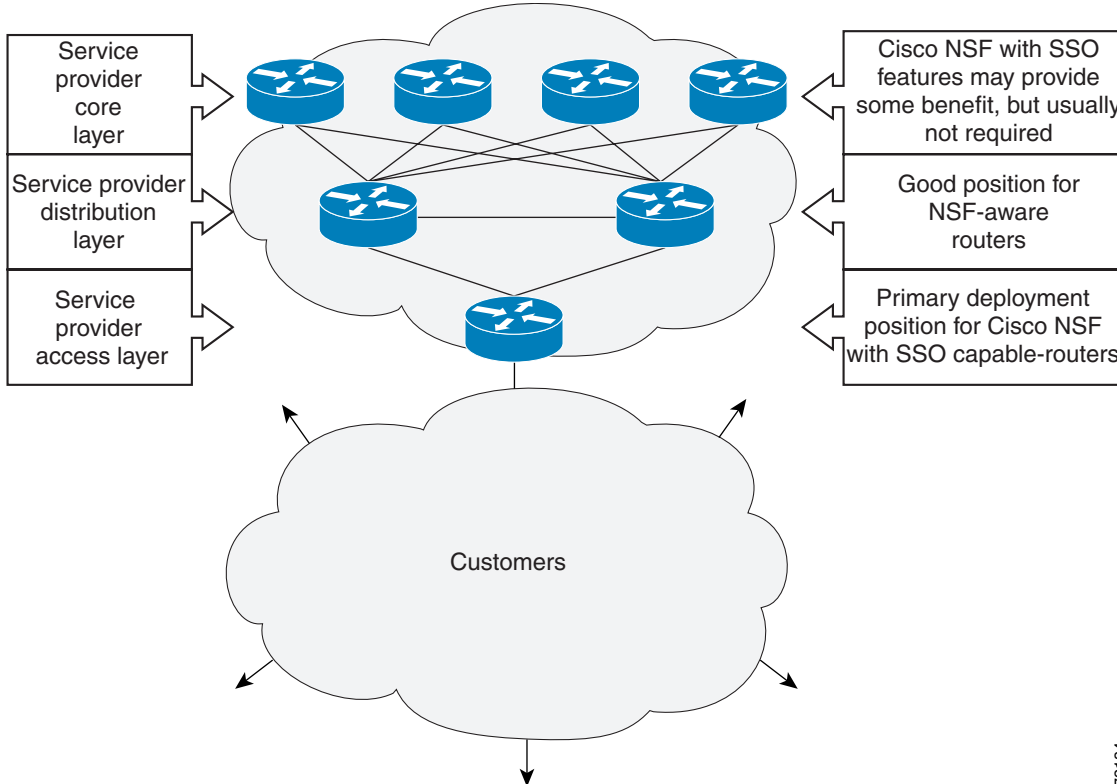

72134

Additional levels of availability may be gained by deploying Cisco NSF with SSO at other points in the network where a single point of failure exists. [Figure 5-2](#) illustrates an optional deployment strategy that applies Cisco NSF with SSO at the enterprise network access layer. In this example, each access point in the enterprise network represents another single point of failure in the network design. In the event of a switchover or a planned software upgrade, enterprise customer sessions would continue uninterrupted through the network in this example.

Figure 5-2 Cisco NSF with SSO Network Deployment: Enterprise Networks

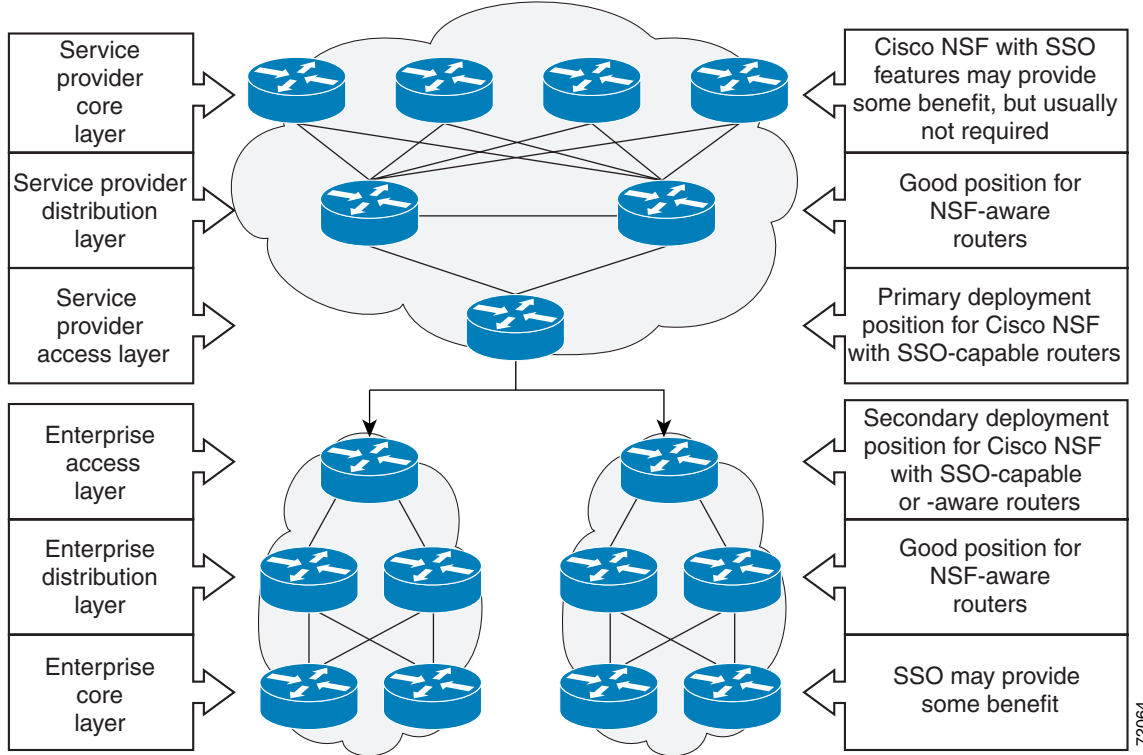

For further information on SSO, see the *Stateful Switchover* document.

## NSF Overview

Cisco NSF works with the SSO feature in Cisco IOS software. SSO is a prerequisite of Cisco NSF. NSF works with SSO to minimize the amount of time a network is unavailable to its users following a switchover. The main objective of Cisco NSF is to continue forwarding IP packets following a supervisor engine switchover.

Usually, when a networking device restarts, all routing peers of that device detect that the device went down and then came back up. This transition results in what is called a routing flap, which could spread across multiple routing domains. Routing flaps caused by routing restarts create routing instabilities, which are detrimental to the overall network performance. Cisco NSF helps to suppress routing flaps in SSO-enabled devices, thus reducing network instability.

Cisco NSF allows for the forwarding of data packets to continue along known routes while the routing protocol information is being restored following a switchover. With Cisco NSF, peer networking devices do not experience routing flaps. Data traffic is forwarded while the standby supervisor engine assumes control from the failed active supervisor engine during a switchover. The ability of physical links to remain up through a switchover and to be kept current with the Forwarding Information Base (FIB) on the active supervisor engine is key to Cisco NSF operation.

## ISSU Process Overview

The ISSU process allows you to perform a Cisco IOS software upgrade or downgrade while the system continues to forward packets. (For an illustration of the commands used during the ISSU process, refer to [Figure 5-8 on page 5-11](#).) Cisco IOS ISSU takes advantage of the Cisco IOS high availability infrastructure—Cisco NSF with SSO and hardware redundancy—and eliminates downtime associated with software upgrades or version changes by allowing changes while the system remains in service (see [Figure 5-3](#)).

SSO and NSF mode support configuration and runtime state synchronization from the active to the standby supervisor engine. For this process to happen, the images on both the active and the standby supervisor engines must be the same. When images on active and standby supervisor engines are different ISSU allows the two supervisor engines to be kept in synchronization even when these two versions of Cisco IOS support different sets of features and commands.

**Figure 5-3** High Availability Features and Hardware Redundancy in the ISSU Process

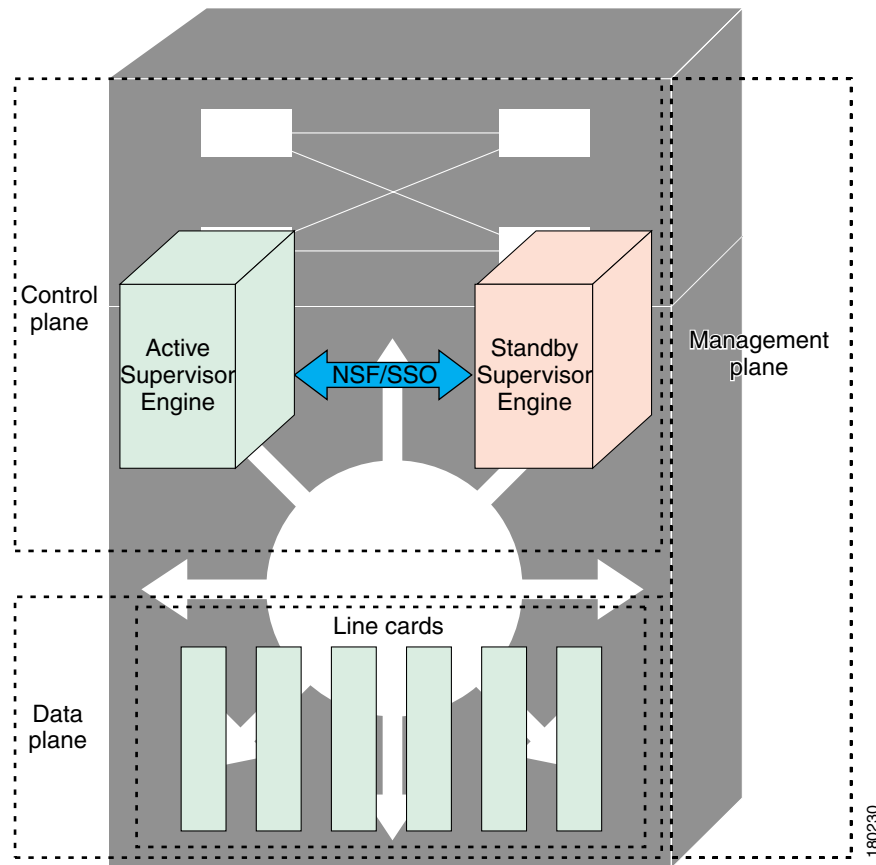

180230

An ISSU-capable switch consists of two supervisor engines (active and standby) and one or more line cards. Before initiating the ISSU process, copy the Cisco IOS software into the file systems of both supervisor engines (see Figure 5-4).



**Note**

In the following figure, Cisco IOS 12.x(y)S represents the *current* version of Cisco IOS.

**Figure 5-4** Install/Copy New Version of Cisco IOS Software on Both Supervisor Engines

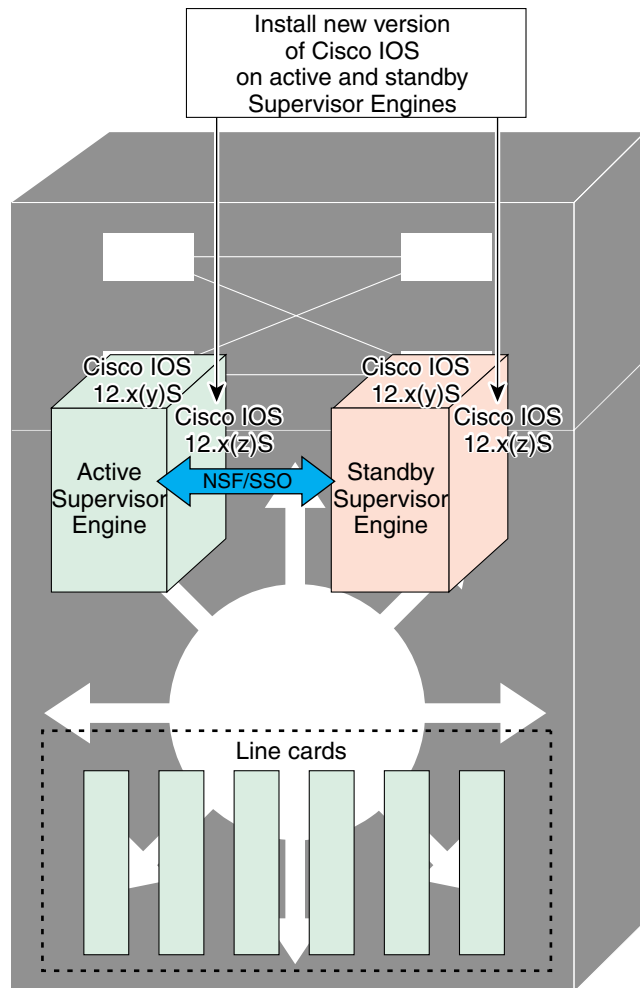

180231

After you have copied the Cisco IOS software to both file systems, load the new version of Cisco IOS software onto the standby supervisor engine (see [Figure 5-5](#)).

**Note**

Without the ISSU feature, you cannot have SSO/NSF functioning between the active and standby supervisor engines when they are running two different versions of Cisco IOS image.

**Figure 5-5** Load New Version of Cisco IOS Software on the Standby Supervisor Engine

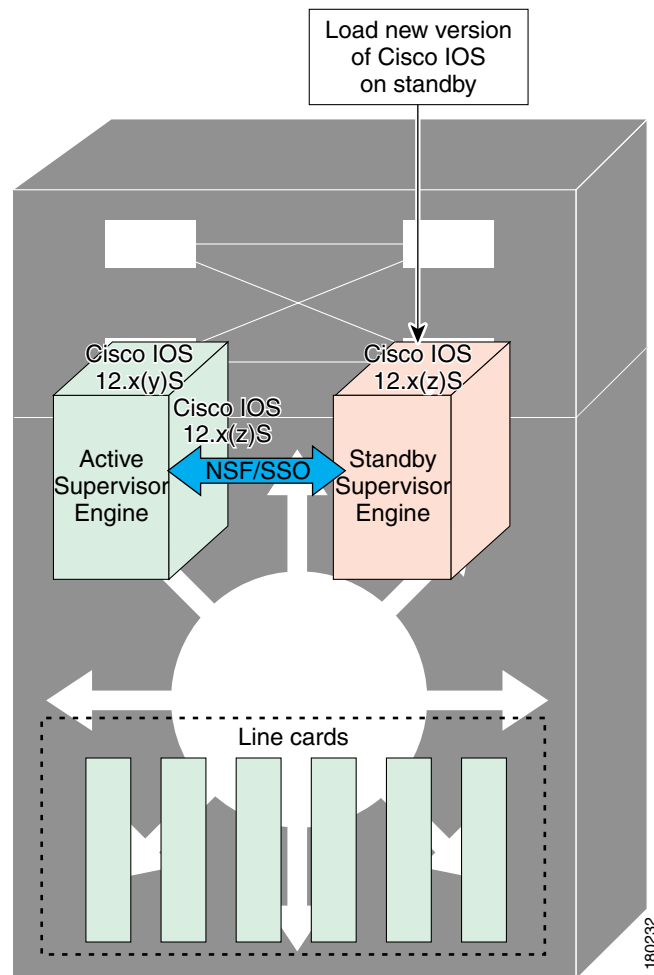



After a switchover (NSF/SSO, not RPR), the standby supervisor engine takes over as the new active supervisor engine (see [Figure 5-6](#)).

**Figure 5-6** Switch Over to Standby Supervisor Engine

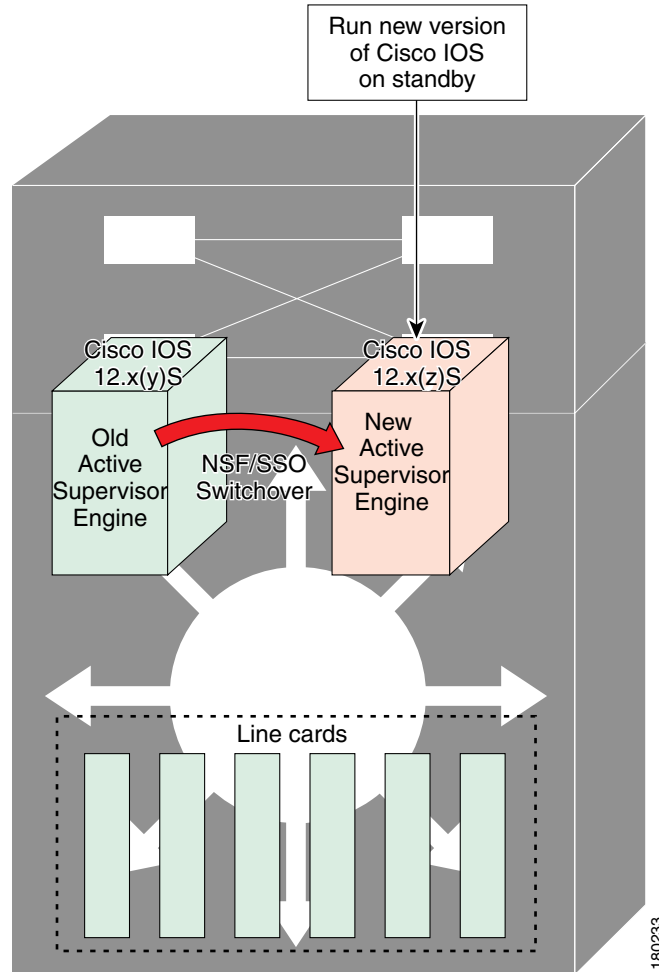

The former active supervisor engine is loaded with an old Cisco IOS image so that if the new active supervisor engine experiences problems, you can abort and conduct a switchover to the former active, which is already running the old image. Next, the former active supervisor engine is loaded with the new version of Cisco IOS software and becomes the new standby supervisor engine (see [Figure 5-7](#)).

**Figure 5-7** Load New Standby Supervisor Engine with New Cisco IOS Software

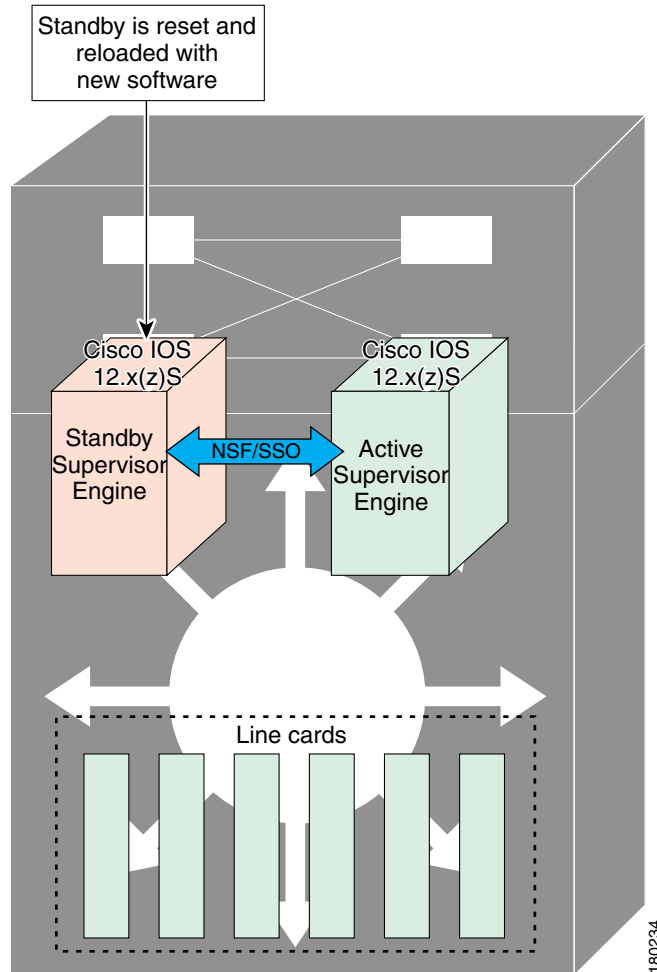

[Figure 5-8](#) shows the steps during the ISSU process.

Figure 5-8 Steps During the ISSU Process

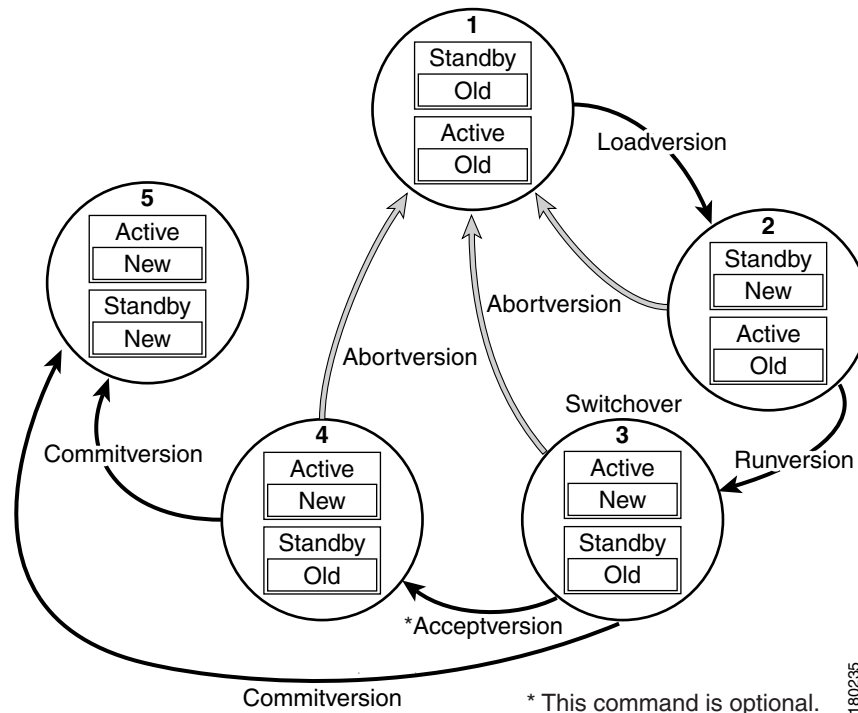

## Guidelines for Performing ISSU

Be aware of the following guidelines while performing the ISSU process:

- Even with ISSU, it is recommended that upgrades be performed during a maintenance window.
- The new features should not be enabled (if they require change of configuration) during the ISSU process.
- In a downgrade scenario, if any feature is not available in the downgrade revision of Cisco IOS software image, that feature should be disabled prior to initiating the ISSU process.

## Versioning Capability in Cisco IOS Software to Support ISSU

Before the introduction of ISSU, the SSO mode of operation required each supervisor engine to be running the same versions of Cisco IOS software.



**Note**

The operating mode of the system in a redundant HA configuration is determined by exchanging version strings when the standby supervisor engine registers with the active supervisor engine.

The system entered SSO mode only if the versions running on the both supervisor engines were the same. If not, the redundancy mode will be changed to RPR. With ISSU capability, the implementation allows two different but compatible release levels of Cisco IOS images to interoperate in SSO mode and enables software upgrades while packet forwarding continues. Version checking done before ISSU capability was introduced is no longer sufficient to allow the system to determine the operating mode.

ISSU requires additional information to determine compatibility between software versions. Therefore, a compatibility matrix is defined that contains information about other images with respect to the one in question. This compatibility matrix represents the compatibility of two software versions, one running on the active and the other on the standby supervisor engine, and to allow the system to determine the highest operating mode it can achieve. Incompatible versions will not be able to progress to SSO operational mode.

The Cisco IOS infrastructure has been internally modified and redesigned to accommodate subsystem versioning with ISSU. Cisco IOS subsystems correspond to feature sets and software component groupings. Features or subsystems that maintain state information across supervisor engines are HA-aware or SSO clients. A mechanism called ISSU Framework, or ISSU protocol, allows subsystems within Cisco IOS software to communicate between the active and the standby supervisor engines and to negotiate the message version for communication between supervisor engines. Internally, all NSF- and SSO-compliant applications or subsystems that are HA-aware must follow this protocol to establish communication with their peer across different versions of software. (For further information on operating modes, see the *Stateful Switchover* document.)

## Compatibility Matrix

You can perform the ISSU process when the Cisco IOS software on both the active and the standby supervisor engine is capable of ISSU and the old and new images are compatible. The compatibility matrix information stores the compatibility among releases as follows:

- **Compatible**—The base-level system infrastructure and all optional HA-aware subsystems are compatible. An in-service upgrade or downgrade between these versions will succeed with minimal service impact. The matrix entry designates the images to be compatible (C).
- **Base-level compatible**—One or more of the optional HA-aware subsystems is not compatible. An in-service upgrade or downgrade between these versions will succeed; however, some subsystems will not be able to maintain state always during the transition from the old to the new version of Cisco IOS. The matrix entry designates the images to be base-level compatible (B).

However, you should be able to perform an ISSU upgrade without any functionality loss even if the matrix entry is B. The downgrade may experience some functionality loss if the newer image had additional functionality.

- **Incompatible**—A core set of system infrastructure exists in Cisco IOS that must be able to interoperate in a stateful manner for SSO to function correctly. If any of these required features or subsystems is not interoperable, then the two versions of the Cisco IOS software images are declared to be incompatible. An in-service upgrade or downgrade between these versions is not possible. The matrix entry designates the images to be incompatible (I). The system operates in RPR mode during the period when the versions of Cisco IOS at the active and standby supervisor engines are incompatible.

If you attempt to perform ISSU with a peer that does not support ISSU, the system automatically uses RPR instead.

The compatibility matrix represents the compatibility relationship a Cisco IOS software image has with all of the other Cisco IOS software versions within the designated support window (for example, all of those software versions the image “knows” about) and is populated and released with every image. The matrix stores compatibility information between its own release and prior releases. It is always the newest release that contains the latest information about compatibility with existing releases in the field. The compatibility matrix is available within the Cisco IOS software image and on Cisco.com so that users can determine in advance whether an upgrade can be done using the ISSU process.

To display the compatibility matrix data between two software versions on a given system, enter the **show issu comp-matrix stored** command.

**Note**

This command is useful *only for verification purposes* because it is available *only after* the ISSU process has started. You might want to check the compatibility matrix prior to starting ISSU. Use the Feature Navigator to obtain the needed information

<http://tools.cisco.com/ITDIT/CFN/jsp/index.jsp>

## SNMP Support for ISSU

SNMP for SSO provides a mechanism for synchronizing the SNMP configurations and the MIBs that support SSO from the active supervisor engine to the standby supervisor engine, assuming that both supervisor engines are running the same version of Cisco IOS software. This assumption is not valid for ISSU.

With ISSU, an SNMP client can handle transformations for the MIBs across two different versions of Cisco IOS, if needed. An SNMP client handles transformation for all MIBs and handles the transmit and receive functionality across the active and standby supervisor engines. During SNMP, a MIB is completely synchronized from the active supervisor engine to the standby supervisor engine only if the versions of the MIB on both Cisco IOS releases are the same.

## Compatibility Verification Using Cisco Feature Navigator

The ISSU application on Cisco Feature Navigator allows you to:

- Select an ISSU-capable image
- Identify which images are compatible with that image
- Compare two images and understand the compatibility level of the images (that is, compatible, base-level compatible, and incompatible)
- Compare two images and see the client compatibility for each ISSU client
- Provide links to release notes for the image

## How to Perform the ISSU Process

Unlike SSO, which is a mode of operation for the device and a prerequisite for performing ISSU, the ISSU process is a series of steps performed while the switch is in operation. The steps result in an upgrade to a new or modified Cisco IOS software, and have a minimal impact to traffic.

**Note**

For an illustration of the process flow for ISSU, refer to [Figure 5-8 on page 5-11](#).

This section includes the following topics:

- [Verifying the ISSU Software Installation, page 5-14](#)
- [Loading New Cisco IOS Software on the Standby Supervisor Engine, page 5-16](#) (required)
- [Switching to the Standby Supervisor Engine, page 5-19](#) (required)
- [Stopping the ISSU Rollback Timer \(Optional\), page 5-21](#) (optional)

- [Loading New Cisco IOS Software on the New Standby Supervisor Engine, page 5-22](#)
- [Aborting a Software Upgrade During ISSU, page 5-24](#)
- [Configuring the Rollback Timer to Safeguard Against Upgrade Issues, page 5-25](#)
- [Displaying ISSU Compatibility Matrix Information, page 5-26](#)

## Verifying the ISSU Software Installation

During the ISSU process, there are five valid states: init, load version, run version, and system reset. Use the **show issu state** command to obtain the current ISSU state:

- Disabled state—The state for the standby supervisor engine while this engine is resetting.
- Init state—The initial state is two supervisor engines, one active and one standby, before the ISSU process is started. It is also the final state after the ISSU process completes.
- Load version (LV) state—The standby supervisor engine is loaded with the new version of Cisco IOS software.
- Run version (RV) state—The **issu runversion** command forces the switchover of the supervisor engines. The newly active supervisor engine now runs the new Cisco IOS software image.
- System reset (SR) state—This state occurs either when you issue the **issu abortversion** command before the Init state is reached, or if the rollback timer expires before you execute the **issu acceptversion** command.

You can verify the ISSU software installation by entering **show** commands to provide information on the state of the during the ISSU process.

	Command or Action	Purpose
Step 1	Switch> <b>enable</b>	Enables privileged EXEC mode. <ul style="list-style-type: none"> <li>• Enter your password if prompted.</li> </ul>
Step 2	Switch# <b>show issu state [detail]</b>	Displays the state of the during the ISSU process.
Step 3	Switch# <b>show redundancy</b>	Displays current or historical status, mode, and related redundancy information about the device.

This example shows how to display the state and the current status of the supervisor engine during the ISSU process:

```
Switch> enable
Switch# show issu state
Switch# show redundancy
```

## Verifying Redundancy Mode Before Beginning the ISSU Process

Before you begin the ISSU process, verify the redundancy mode for the system and be sure to configure NSF and SSO.

The following example displays verification that the system is in SSO mode, that slot 1 is the active supervisor engine, and that slot 2 is the standby supervisor engine. Both supervisor engines are running the same Cisco IOS software image.

```
Switch# show redundancy states
my state = 13 -ACTIVE
peer state = 8 -STANDBY HOT
Mode = Duplex
Unit = Primary
Unit ID = 1

Redundancy Mode (Operational) = Stateful Switchover
Redundancy Mode (Configured) = Stateful Switchover
Redundancy State = Stateful Switchover
Maintenance Mode = Disabled
Manual Swact = enabled
Communications = Up

client count = 39
client_notification_TMR = 240000 milliseconds
keep_alive TMR = 9000 milliseconds
keep_alive count = 0
keep_alive threshold = 18
RF debug mask = 0x0

Switch# show redundancy
Redundant System Information :
-----
Available system uptime = 1 minute
Switchovers system experienced = 0
Standby failures = 0
Last switchover reason = none

Hardware Mode = Duplex
Configured Redundancy Mode = Stateful Switchover
Operating Redundancy Mode = Stateful Switchover
Maintenance Mode = Disabled
Communications = Up

Current Processor Information :
-----
Active Location = slot 1
Current Software state = ACTIVE
Uptime in current state = 0 minutes
Image Version = Cisco IOS Software, Catalyst 4500 L3 Switch Software
(cat4500-ENTSERVICES-M), Version 12.2(31)SGA, RELEASE SOFTWARE (fc1)
Technical Support: http://www.cisco.com/techsupport
Copyright (c) 1986-2006 by Cisco Systems, Inc.
Compiled Tue 05-Sep-06 16:16 by sanjdas
BOOT = bootflash:old_image,1;
Configuration register = 0x822

Peer Processor Information :
-----
Standby Location = slot 2
Current Software state = STANDBY HOT
Uptime in current state = 1 minute
Image Version = Cisco IOS Software, Catalyst 4500 L3 Switch Software
(cat4500-ENTSERVICES-M), Version 12.2(31)SGA, RELEASE SOFTWARE (fc1)
Technical Support: http://www.cisco.com/techsupport
Copyright (c) 1986-2006 by Cisco Systems, Inc.
Compiled Tue 05-Sep-06 16:16 by sanjdas
BOOT = bootflash:old_image,1;
Configuration register = 0x822
```

## Verifying the ISSU State Before Beginning the ISSU Process

Ensure that the active and standby supervisor engines are up and in ISSU Init state and that the boot variables are set and pointing to valid files.

The following example displays the ISSU state before the process begins:

```
Switch# show issu state detail
      Slot = 1
      RP State = Active
      ISSU State = Init
      Boot Variable = bootflash:old_image,1;
      Operating Mode = Stateful Switchover
      Primary Version = N/A
      Secondary Version = N/A
      Current Version = bootflash:old_image

      Slot = 2
      RP State = Standby
      ISSU State = Init
      Boot Variable = bootflash:old_image,1;
      Operating Mode = Stateful Switchover
      Primary Version = N/A
      Secondary Version = N/A
      Current Version = bootflash:old_image
```

The new version of the Cisco IOS software must be present on both of the supervisor engines. The directory information displayed for each of the supervisor engines (or supervisor engines) shows that the new version is present.

```
Switch# dir bootflash:
Directory of bootflash:/

   5  -rwx   13636500   Sep 6 2006 09:32:33 +00:00  old_image
   6  -rwx   13636500   Sep 6 2006 09:34:07 +00:00  new_image

61341696 bytes total (1111388 bytes free)

Switch# dir slavebootflash:
Directory of slavebootflash:/

   4  -rwx   13636500   Sep 6 2006 09:40:10 +00:00  old_image
   5  -rwx   13636500   Sep 6 2006 09:42:13 +00:00  new_image

61341696 bytes total (1116224 bytes free)
```

## Loading New Cisco IOS Software on the Standby Supervisor Engine

This task describes how to use ISSU to load a new version of Cisco IOS software to the standby supervisor engine.

### Prerequisites

- Ensure that the new version of Cisco IOS software image is already present in the file system of both the active and standby supervisor engines. Also ensure that appropriate boot parameters (BOOT string and config-register) are set for the standby supervisor engine.
- Optionally, perform additional tests and commands to determine the current state of peers and interfaces for later comparison.



- Ensure the system (both active and standby supervisor engines) is in SSO redundancy mode. If the system is in RPR mode rather than SSO mode, you can still upgrade the system using the ISSU CLI commands, but the system will experience extended packet loss during the upgrade.'

Refer to the *Stateful Switchover* document for more details on how to configure SSO mode on supervisor engines.

- For ISSU to function, the image names on the active and standby supervisor engines must match.

Perform the following steps at the active supervisor engine:

	Command or Action	Purpose
Step 1	Switch> <b>enable</b>	Enables privileged EXEC mode. <ul style="list-style-type: none"> <li>• Enter your password if prompted.</li> </ul>
Step 2	Switch# <b>issu loadversion</b> <i>active-slot</i> <i>active-image-new standby-slot standby-image-new</i> [ <b>forced</b> ]	Starts the ISSU process and (optionally) overrides the automatic rollback when the new Cisco IOS software version is detected to be incompatible.  It may take several seconds after the <b>issu loadversion</b> command is entered for Cisco IOS software to load onto the standby supervisor engine and for the standby supervisor engine to transition to SSO mode. This causes the standby supervisor engine to reload with the new image.  If you use the <b>forced</b> option, the standby supervisor engine is booted with the new image. After the image is loaded on the standby supervisor engine, if the image is incompatible, the system is forced to the RPR mode. Otherwise the system will continue in the SSO mode.
Step 3	Switch# <b>show issu state</b> [ <b>detail</b> ]	Displays the state of the during the ISSU process. At this point in the ISSU process, use this command to check that the standby supervisor engine is loaded and is in SSO mode.  It may take several seconds after entering the <b>issu loadversion</b> command for Cisco IOS software to load onto the standby supervisor engine and the standby supervisor engine to transition to SSO mode. If you enter the <b>show issu state</b> command too quickly, you may not see the information you need.
Step 4	Switch# <b>show redundancy</b> [ <b>states</b> ]	Displays redundancy facility state information.

This example shows how to start the ISSU process, boot the standby supervisor engine in the Standby Hot state, and load the standby supervisor engine slot (2) with the new image:

```
Switch> enable
Switch# issu loadversion 1 bootflash:new_image 2 slavebootflash:new_image
Switch# show issu state detail
      Slot = 1
      RP State = Active
      ISSU State = Load Version
      Boot Variable = bootflash:old_image,12
      Operating Mode = Stateful Switchover
      Primary Version = bootflash:old_image
      Secondary Version = bootflash:new_image
      Current Version = bootflash:old_image
```

```

        Slot = 2
        RP State = Standby
        ISSU State = Load Version
        Boot Variable = bootflash:new_image,12;bootflash:old_image,12
        Operating Mode = Stateful Switchover
        Primary Version = bootflash:old_image
        Secondary Version = bootflash:new_image
        Current Version = bootflash:new_image

```

```

Switch# show redundancy states
my state = 13 -ACTIVE
peer state = 8 -STANDBY HOT
  Mode = Duplex
  Unit = Primary
  Unit ID = 1

```

```

Redundancy Mode (Operational) = Stateful Switchover
Redundancy Mode (Configured) = Stateful Switchover
Redundancy State = Stateful Switchover
Maintenance Mode = Disabled
  Manual Swact = enabled
  Communications = Up

```

```

  client count = 39
  client_notification_TMR = 240000 milliseconds
  keep_alive TMR = 9000 milliseconds
  keep_alive count = 1
  keep_alive threshold = 18
  RF debug mask = 0x0

```

The following example shows how the forced option places the system in RPR mode:

```

Switch> enable
Switch# issu loadversion 1 bootflash:new_image 2 slavebootflash:new_image forced
Switch# show issu state detail
        Slot = 1
        RP State = Active
        ISSU State = Load Version
        Boot Variable = bootflash:old_image,12
        Operating Mode = RPR
        Primary Version = bootflash:old_image
        Secondary Version = bootflash:new_image
        Current Version = bootflash:old_image

        Slot = 2
        RP State = Standby
        ISSU State = Load Version
        Boot Variable = bootflash:new_image,12;bootflash:old_image,12
        Operating Mode = RPR
        Primary Version = bootflash:old_image
        Secondary Version = bootflash:new_image
        Current Version = bootflash:new_image

```

The following example shows the redundancy mode as RPR:

```
Switch# show redundancy states
  my state = 13 -ACTIVE
  peer state = 4 -STANDBY COLD
    Mode = Duplex
    Unit = Primary
    Unit ID = 1

Redundancy Mode (Operational) = RPR
Redundancy Mode (Configured) = Stateful Switchover
Redundancy State = RPR
Maintenance Mode = Disabled
  Manual Swact = enabled
  Communications = Up

  client count = 39
  client_notification_TMR = 240000 milliseconds
    keep_alive TMR = 9000 milliseconds
    keep_alive count = 1
  keep_alive threshold = 18
    RF debug mask = 0x0
```

## Switching to the Standby Supervisor Engine

This task describes how to switchover to the standby supervisor engine, which is running the new Cisco IOS software image.

Perform the following steps at the active supervisor engine.

	Command or Action	Purpose
Step 1	Switch> <b>enable</b>	Enables privileged EXEC mode. <ul style="list-style-type: none"> <li>Enter your password if prompted.</li> </ul>
Step 2	Switch# <b>issu runversion</b> <i>standby-slot</i> <i>[standby-image-new]</i>	Forces a switchover from the active to the standby supervisor engine and reloads the former active (current standby) supervisor engines with the old image.  When you enter the <b>issu runversion</b> command, an SSO switchover will be performed, and NSF procedures will be invoked if so configured.
Step 3	Switch# <b>show issu state</b> [detail]	Displays the state of the during the ISSU process. At this point in the ISSU process, use this command to check that a switchover occurs to slot 2.
Step 4	Switch# <b>show redundancy</b> [states]	Displays redundancy facility state information.

This example shows how to cause a switchover to the former standby supervisor engine (slot 2), reset the former active supervisor engine and reload it with the old image so it becomes the standby supervisor engine:

```
Switch> enable
Switch# issu runversion 2 slavebootflash:new_image
This command will reload the Active unit. Proceed ? [confirm]
```

A switchover happens at this point. At the new active supervisor engine, do the following after old active supervisor engine comes up as standby.

```
Switch# show issu state detail
      Slot = 2
      RP State = Active
      ISSU State = Run Version
      Boot Variable = bootflash:new_image,12;bootflash:old_image,12
      Operating Mode = Stateful Switchover
      Primary Version = bootflash:new_image
      Secondary Version = bootflash:old_image
      Current Version = bootflash:new_image

      Slot = 1
      RP State = Standby
      ISSU State = Run Version
      Boot Variable = bootflash:old_image,12
      Operating Mode = Stateful Switchover
      Primary Version = bootflash:new_image
      Secondary Version = bootflash:old_image
      Current Version = bootflash:old_image
```

**Note**

The new active supervisor engine is now running the new version of software, and the standby supervisor engine is running the old version of software and is in the standby hot state.

```
Switch# show redundancy states
my state = 13 -ACTIVE
peer state = 8 -STANDBY HOT
  Mode = Duplex
  Unit = Secondary
  Unit ID = 2

Redundancy Mode (Operational) = Stateful Switchover
Redundancy Mode (Configured) = Stateful Switchover
Redundancy State = Stateful Switchover
Maintenance Mode = Disabled
  Manual Swact = enabled
  Communications = Up

  client count = 39
  client_notification_TMR = 240000 milliseconds
  keep_alive TMR = 9000 milliseconds
  keep_alive count = 1
  keep_alive threshold = 18
  RF debug mask = 0x0
```

Once Runversion has completed, the new active supervisor engine will be running the new version of software and the previously active supervisor engine will now become the standby supervisor engine. The standby will be reset and reloaded, but it will remain on the previous version of software and come back online in standbyhot status. The following example shows how to verify these conditions:

```
Switch# show redundancy
Redundant System Information :
-----
      Available system uptime = 23 minutes
Switchovers system experienced = 1
      Standby failures = 0
      Last switchover reason = user forced
```

```

                Hardware Mode = Duplex
Configured Redundancy Mode = Stateful Switchover
                Operating Redundancy Mode = Stateful Switchover
                Maintenance Mode = Disabled
                Communications = Up

Current Processor Information :
-----
                Active Location = slot 2
                Current Software state = ACTIVE
                Uptime in current state = 11 minutes
                Image Version = Cisco IOS Software, Catalyst 4500 L3 Switch Software
(cat4500-ENTSERVICES-M), Version 12.2(31)SGA, RELEASE SOFTWARE (fc1)
                Technical Support: http://www.cisco.com/techsupport
                Copyright (c) 1986-2006 by Cisco Systems, Inc.
                Compiled Tue 05-Sep-06 16:16 by sanjdas
                BOOT = bootflash:new_image,12;bootflash:old_image,12
                Configuration register = 0x822

Peer Processor Information :
-----
                Standby Location = slot 1
                Current Software state = STANDBY HOT
                Uptime in current state = 4 minutes
                Image Version = Cisco IOS Software, Catalyst 4500 L3 Switch Software
(cat4500-ENTSERVICES-M), Version 12.2(31)SGA, RELEASE SOFTWARE (fc1)
                Technical Support: http://www.cisco.com/techsupport
                Copyright (c) 1986-2006 by Cisco Systems, Inc.
                Compiled Tue 05-Sep-06 16:16 by sanjdas
                BOOT = bootflash:old_image,12
                Configuration register = 0x822

```

## Stopping the ISSU Rollback Timer (Optional)

This optional task describes how to stop the rollback timer.

If you do not run the following procedure before the rollback timer “timeout,” the system automatically aborts the ISSU process and reverts to the original Cisco IOS software version. By default the rollback timer is 45 minutes.

Use the following information to decide what action you should take:

- If you want to retain your switch in this state for an extended period, you need to stop the rollback timer (then validate and run the **commitversion** command directly).
- If you want to proceed to the following step (running “acceptversion”) within the rollback timer window of 45 minutes, you do not need to stop the roll-back timer.



### Note

The **issu acceptversion** command may be optionally executed after the **issu runversion** command.

	Command or Action	Purpose
Step 1	Switch> <b>enable</b>	Enables privileged EXEC mode. <ul style="list-style-type: none"> <li>Enter your password if prompted.</li> </ul>
Step 2	Switch# <b>issu acceptversion</b> <i>active-slot</i> <i>[active-image-new]</i>	Halts the rollback timer and ensures the new Cisco IOS ISSU process is not automatically aborted during the ISSU process.  Enter the <b>issu acceptversion</b> command within the time period specified by the rollback timer to acknowledge that the supervisor engine has achieved connectivity to the outside world; otherwise, the ISSU process is terminated, and the system reverts to the previous version of Cisco IOS software by switching to the standby supervisor engine.
Step 3	Switch# <b>show issu rollback-timer</b>	Displays the amount of time left before an automatic rollback will occur.

This example displays the Timer before you stop it. In the following example, the “Automatic Rollback Time” information indicates the amount of time remaining before an automatic rollback will occur.

```
Switch> enable
Switch# show issu rollback-timer
    Rollback Process State = In progress
    Configured Rollback Time = 45:00
    Automatic Rollback Time = 38:30

Switch# issu acceptversion 2 bootflash:new_image
% Rollback timer stopped. Please issue the commitversion command.
Switch# show issu rollback-timer
    Rollback Process State = Not in progress
    Configured Rollback Time = 45:00
```

## Loading New Cisco IOS Software on the New Standby Supervisor Engine

This task explains how to load new version of Cisco IOS software to the new standby supervisor engine. Perform the following steps at the active supervisor engine.

	Command or Action	Purpose
Step 1	Switch> <b>enable</b>	Enables privileged EXEC mode. <ul style="list-style-type: none"> <li>Enter your password if prompted.</li> </ul>
Step 2	Switch# <b>issu commitversion</b> <i>standby-slot-number</i> <i>[standby-image-new]</i>	Allows the new Cisco IOS software image to be loaded into the standby supervisor engine.
Step 3	Switch# <b>show redundancy</b> [ <i>states</i> ]	Displays redundancy facility state information.
Step 4	Switch# <b>show issu state</b> [ <i>detail</i> ]	Displays the state of the during the ISSU process. At this point in the ISSU process, use this command to check that a switchover occurs to slot 2.

This example shows how to reset and reload the current standby supervisor engine (slot 1) with the new Cisco IOS software version. After entering the **commitversion** command, the standby supervisor engine will boot in the Standby Hot state.

```
Switch> enable
Switch# issu commitversion 1 slavebootflash:new_image
```

Wait till standby supervisor is reloaded with the new image. Then apply the following:

```
Switch# show redundancy states
00:17:12: %RF-5-RF_TERMINAL_STATE: Terminal state reached for (SSO)
  my state = 13 -ACTIVE
  peer state = 8 -STANDBY HOT
    Mode = Duplex
    Unit = Secondary
  Unit ID = 2
```

```
Redundancy Mode (Operational) = Stateful Switchover
Redundancy Mode (Configured) = Stateful Switchover
Redundancy State = Stateful Switchover
Maintenance Mode = Disabled
  Manual Swact = enabled
  Communications = Up
```

```
  client count = 39
  client_notification_TMR = 240000 milliseconds
    keep_alive TMR = 9000 milliseconds
    keep_alive count = 0
  keep_alive threshold = 18
  RF debug mask = 0x0
```

```
Switch# show redundancy
```

```
Redundant System Information :
```

```
-----
  Available system uptime = 41 minutes
  Switchovers system experienced = 1
    Standby failures = 1
  Last switchover reason = user forced
```

```
  Hardware Mode = Duplex
  Configured Redundancy Mode = Stateful Switchover
  Operating Redundancy Mode = Stateful Switchover
  Maintenance Mode = Disabled
  Communications = Up
```

```
Current Processor Information :
```

```
-----
  Active Location = slot 2
  Current Software state = ACTIVE
  Uptime in current state = 29 minutes
    Image Version = Cisco IOS Software, Catalyst 4500 L3 Switch Software
    (cat4500-ENTSERVICES-M), Version 12.2(31)SGA, RELEASE SOFTWARE (fc1)
  Technical Support: http://www.cisco.com/techsupport
  Copyright (c) 1986-2006 by Cisco Systems, Inc.
  Compiled Tue 05-Sep-06 16:16 by sanjdas
    BOOT = bootflash:new_image,12;bootflash:old_image,1;
  Configuration register = 0x822
```

```
Peer Processor Information :
```

```
-----
  Standby Location = slot 1
  Current Software state = STANDBY HOT
  Uptime in current state = 12 minutes
```

```

Image Version = Cisco IOS Software, Catalyst 4500 L3 Switch Software
(cat4500-ENTSERVICES-M), Version 12.2(31)SGA, RELEASE SOFTWARE (fc1)
Technical Support: http://www.cisco.com/techsupport
Copyright (c) 1986-2006 by Cisco Systems, Inc.
Compiled Tue 05-Sep-06 16:16 by sanjdas
      BOOT = bootflash:new_image,12;bootflash:old_image,1;
Configuration register = 0x822

Switch# show issu state detail
      Slot = 2
      RP State = Active
      ISSU State = Init
      Boot Variable = bootflash:new_image,12;bootflash:old_image,1;
      Operating Mode = Stateful Switchover
      Primary Version = N/A
      Secondary Version = N/A
      Current Version = bootflash:new_image

      Slot = 1
      RP State = Standby
      ISSU State = Init
      Boot Variable = bootflash:new_image,12;bootflash:old_image,1;
      Operating Mode = Stateful Switchover
      Primary Version = N/A
      Secondary Version = N/A
      Current Version = bootflash:new_image

```

The ISSU process has been completed. At this stage, any further Cisco IOS software version upgrade or downgrade will require that a new ISSU process be invoked.

## Aborting a Software Upgrade During ISSU

You can abort the ISSU process at any stage manually (prior to entering the **issu commitversion** command) by entering the **issu abortversion** command. The ISSU process also aborts on its own if the software detects a failure.



### Note

If you enter the **issu abortversion** command before the standby supervisor engine becomes hot, the traffic might be disrupted.

If you abort the process after you issue the **issu loadversion** command, the standby supervisor engine is reset and reloaded with the original software.

If the process is aborted after you enter either the **issu runversion** or **issu acceptversion** command, then a second switchover is performed to the new standby supervisor engine that is still running the original software version. The supervisor engine that had been running the new software is reset and reloaded with the original software version.



### Note

Ensure that the standby supervisor is fully booted *before* issuing the **abortversion** command on an active sup command.

The following task describes how to abort the ISSU process before you complete the ISSU process with the **issu commitversion** command.

Perform the following task on the active supervisor engine.



	Command or Action	Purpose
Step 1	Switch> <b>enable</b>	Enables privileged EXEC mode. <ul style="list-style-type: none"> <li>• Enter your password if prompted.</li> </ul>
Step 2	Switch# <b>issu abortversion</b> <i>active slot</i> <i>[active-image-new]</i>	Cancels the ISSU upgrade or downgrade process in progress and restores the router to its state before the process had started.

This example shows how to abort the ISSU process on slot number 2, the slot for the current active supervisor engine:

```
Switch> enable
Switch# issu abortversion 2
```

## Configuring the Rollback Timer to Safeguard Against Upgrade Issues

Cisco IOS software maintains an ISSU rollback timer, to safeguard against an upgrade that may leave the new active supervisor engine in a state in which communication with the standby supervisor engine is severed.

You may want to configure the rollback timer to fewer than 45 minutes (the default) so that the user need not wait in case the new software is not committed or the connection to the switch was lost while it was in runversion mode. A user may want to configure the rollback timer to more than 45 minutes in order to have enough time to verify the operation of the new Cisco IOS software before committing the new image.



### Note

The valid timer value range is from 0 to 7200 seconds (two hours). A value of 0 seconds disables the rollback timer.

Once you are satisfied that the ISSU process has been successful and you want to remain in the current state, you must indicate acceptance by issuing the **issu acceptversion** command, which stops the rollback timer. Therefore, entering the **issu acceptversion** command is extremely important to moving the ISSU process forward.

Issuing the **issu commitversion** command at this stage is equal to entering both the **issu acceptversion** and the **issu commitversion** commands. Use the **issu commitversion** command if you do not intend to run in the current state for a period of time and are satisfied with the new software version.



### Note

The rollback timer can be configured only in the ISSU Init state.

This task explains how to configure the rollback timer.

	Command or Action	Purpose
Step 1	Switch> <b>enable</b>	Enables privileged EXEC mode. <ul style="list-style-type: none"> <li>• Enter your password if prompted.</li> </ul>
Step 2	Switch# <b>configure terminal</b>	Enters global configuration mode.
Step 3	Switch(config)# <b>issu set rollback-timer</b> <i>hh:mm:ss</i>	Configures the rollback timer value.

	Command or Action	Purpose
Step 4	Switch(config)# <b>exit</b>	Returns the user to privileged EXEC mode.
Step 5	Switch# <b>show issu rollback-timer</b>	Displays the current setting of the ISSU rollback timer.

This example shows how to set the rollback timer to 3600 seconds:

```
Switch> enable
Switch# configure terminal
Enter configuration commands, one per line. End with CNTL/Z.
Switch(config)# issu set rollback-timer 3600
% Rollback timer value set to [ 3600 ] seconds

Switch(config)# exit

Switch# show issu rollback-timer
Rollback Process State = Not in progress
Configured Rollback Time = 60:00
```

The Rollback Timer cannot be set in LV state, as the following example illustrates:

```
Switch# show issu state detail
Slot = 1
RP State = Active
ISSU State = Load Version
Boot Variable = bootflash:old_image,12
Operating Mode = RPR
Primary Version = bootflash:old_image
Secondary Version = bootflash:new_image
Current Version = bootflash:old_image

Slot = 2
RP State = Standby
ISSU State = Load Version
Boot Variable = bootflash:new_image,12;bootflash:old_image,12
Operating Mode = RPR
Primary Version = bootflash:old_image
Secondary Version = bootflash:new_image
Current Version = bootflash:new_image

Switch# show issu rollback-timer
Rollback Process State = Not in progress
Configured Rollback Time = 60:00

Switch# configure terminal
Enter configuration commands, one per line. End with CNTL/Z.
Switch(config)# issu set rollback-timer 20
% ISSU state should be [ init ] to set the rollback timer
```

## Displaying ISSU Compatibility Matrix Information

The ISSU compatibility matrix contains information about other software images about the version in question. This compatibility matrix represents the compatibility of the two software versions, one running on the active and the other on the standby supervisor engine, and the matrix allows the system to determine the highest operating mode it can achieve. This information helps the user identify whether to use ISSU.

This task shows how to display information about the ISSU compatibility matrix.

	Command or Action	Purpose
Step 1	Switch> <b>enable</b>	Enables privileged EXEC mode. <ul style="list-style-type: none"> <li>• Enter your password if prompted.</li> </ul>
Step 2	Switch# <b>show issu comp-matrix</b> { <b>negotiated</b>   <b>stored</b>   <b>xml</b> }	Displays information regarding the ISSU compatibility matrix. <ul style="list-style-type: none"> <li>• <b>negotiated</b>—Displays negotiated compatibility matrix information.</li> <li>• <b>stored</b>—Displays negotiated compatibility matrix information.</li> <li>• <b>xml</b>—Displays negotiated compatibility matrix information in XML format.</li> </ul>

This example shows how to display negotiated information regarding the compatibility matrix:

```
Switch> enable
Switch# show issu comp-matrix negotiated

CardType: WS-C4507R(112), Uid: 2, Image Ver: 12.2(31)SGA
Image Name: cat4500-ENTSERVICES-M

Cid      Eid      Sid      pSid    pUid     Compatibility
=====
2        1        262151   3        1        COMPATIBLE
3        1        262160   5        1        COMPATIBLE
4        1        262163   9        1        COMPATIBLE
5        1        262186   25       1        COMPATIBLE
7        1        262156   10       1        COMPATIBLE
8        1        262148   7        1        COMPATIBLE
9        1        262155   1        1        COMPATIBLE
10       1        262158   2        1        COMPATIBLE
11       1        262172   6        1        COMPATIBLE
100      1        262166   13       1        COMPATIBLE
110      113     262159   14       1        COMPATIBLE
200      1        262167   24       1        COMPATIBLE
2002     1        -        -        -        UNAVAILABLE
2003     1        262185   23       1        COMPATIBLE
2004     1        262175   16       1        COMPATIBLE
2008     1        262147   26       1        COMPATIBLE
2008     1        262168   27       1        COMPATIBLE
2010     1        262171   32       1        COMPATIBLE
2012     1        262180   31       1        COMPATIBLE
2021     1        262170   41       1        COMPATIBLE
2022     1        262152   42       1        COMPATIBLE
2023     1        -        -        -        UNAVAILABLE
2024     1        -        -        -        UNAVAILABLE
2025     1        -        -        -        UNAVAILABLE
2026     1        -        -        -        UNAVAILABLE
2027     1        -        -        -        UNAVAILABLE
2028     1        -        -        -        UNAVAILABLE
2054     1        262169   8        1        COMPATIBLE
2058     1        262154   29       1        COMPATIBLE
```

2059	1	262179	30	1	COMPATIBLE
2067	1	262153	12	1	COMPATIBLE
2068	1	196638	40	1	COMPATIBLE
2070	1	262145	21	1	COMPATIBLE
2071	1	262178	11	1	COMPATIBLE
2072	1	262162	28	1	COMPATIBLE
2073	1	262177	33	1	COMPATIBLE
2077	1	262165	35	1	COMPATIBLE
2078	1	196637	34	1	COMPATIBLE
2079	1	262176	36	1	COMPATIBLE
2081	1	262150	37	1	COMPATIBLE
2082	1	262161	39	1	COMPATIBLE
2083	1	262184	20	1	COMPATIBLE
2084	1	262183	38	1	COMPATIBLE
4001	101	262181	17	1	COMPATIBLE
4002	201	262164	18	1	COMPATIBLE
4003	301	262182	19	1	COMPATIBLE
4004	401	262146	22	1	COMPATIBLE
4005	1	262149	4	1	COMPATIBLE

## Message group summary:

Cid	Eid	GrpId	Sid	pSid	pUId	Nego Result
2	1	1	262151	3	1	Y
3	1	1	262160	5	1	Y
4	1	1	262163	9	1	Y
5	1	1	262186	25	1	Y
7	1	1	262156	10	1	Y
8	1	1	262148	7	1	Y
9	1	1	262155	1	1	Y
10	1	1	262158	2	1	Y
11	1	1	262172	6	1	Y
100	1	1	262166	13	1	Y
110	113	115	262159	14	1	Y
200	1	1	262167	24	1	Y
2002	1	2	-	-	-	N - did not negotiate
2003	1	1	262185	23	1	Y
2004	1	1	262175	16	1	Y
2008	1	1	262147	26	1	Y
2008	1	2	262168	27	1	Y
2010	1	1	262171	32	1	Y
2012	1	1	262180	31	1	Y
2021	1	1	262170	41	1	Y
2022	1	1	262152	42	1	Y
2023	1	1	-	-	-	N - did not negotiate
2024	1	1	-	-	-	N - did not negotiate
2025	1	1	-	-	-	N - did not negotiate
2026	1	1	-	-	-	N - did not negotiate
2027	1	1	-	-	-	N - did not negotiate
2028	1	1	-	-	-	N - did not negotiate
2054	1	1	262169	8	1	Y
2058	1	1	262154	29	1	Y
2059	1	1	262179	30	1	Y
2067	1	1	262153	12	1	Y
2068	1	1	196638	40	1	Y
2070	1	1	262145	21	1	Y
2071	1	1	262178	11	1	Y
2072	1	1	262162	28	1	Y
2073	1	1	262177	33	1	Y
2077	1	1	262165	35	1	Y
2078	1	1	196637	34	1	Y

2079	1	1	262176	36	1	Y
2081	1	1	262150	37	1	Y
2082	1	1	262161	39	1	Y
2083	1	1	262184	20	1	Y
2084	1	1	262183	38	1	Y
4001	101	1	262181	17	1	Y
4002	201	1	262164	18	1	Y
4003	301	1	262182	19	1	Y
4004	401	1	262146	22	1	Y
4005	1	1	262149	4	1	Y

## List of Clients:

Cid	Client Name	Base/Non-Base
2	ISSU Proto client	Base
3	ISSU RF	Base
4	ISSU CF client	Base
5	ISSU Network RF client	Base
7	ISSU CONFIG SYNC	Base
8	ISSU ifIndex sync	Base
9	ISSU IPC client	Base
10	ISSU IPC Server client	Base
11	ISSU Red Mode Client	Base
100	ISSU rfs client	Base
110	ISSU ifs client	Base
200	ISSU Event Manager client	Base
2002	CEF Push ISSU client	Base
2003	ISSU XDR client	Base
2004	ISSU SNMP client	Non-Base
2008	ISSU Tableid Client	Base
2010	ARP HA	Base
2012	ISSU HSRP Client	Non-Base
2021	XDR Int Priority ISSU cli	Base
2022	XDR Proc Priority ISSU cl	Base
2023	FIB HWIDB ISSU client	Base
2024	FIB IDB ISSU client	Base
2025	FIB HW subblock ISSU clie	Base
2026	FIB SW subblock ISSU clie	Base
2027	Adjacency ISSU client	Base
2028	FIB IPV4 ISSU client	Base
2054	ISSU process client	Base
2058	ISIS ISSU RTR client	Non-Base
2059	ISIS ISSU UPD client	Non-Base
2067	ISSU PM Client	Base
2068	ISSU PAGP_SWITCH Client	Non-Base
2070	ISSU Port Security client	Non-Base
2071	ISSU Switch VLAN client	Non-Base
2072	ISSU dot1x client	Non-Base
2073	ISSU STP	Non-Base
2077	ISSU STP MSTP	Non-Base
2078	ISSU STP IEEE	Non-Base
2079	ISSU STP RSTP	Non-Base
2081	ISSU DHCP Snooping client	Non-Base
2082	ISSU IP Host client	Non-Base
2083	ISSU Inline Power client	Non-Base
2084	ISSU IGMP Snooping client	Non-Base
4001	ISSU C4K Chassis client	Base
4002	ISSU C4K Port client	Base
4003	ISSU C4K Rkios client	Base
4004	ISSU C4K HostMan client	Base
4005	ISSU C4k GaliosRedundancy	Base

This example shows how to display stored information regarding the compatibility matrix:

```
Switch# show issu comp-matrix stored
```

```
Number of Matrices in Table = 1
```

```
(1) Matrix for cat4500-ENTSERVICES-M(112) - cat4500-ENTSERVICES-M(112)
```

```
=====
```

```
Start Flag (0xDEADBABE)
```

```

My Image ver: 12.2(52)SG
Peer Version  Compatibility
-----
12.2(31)SGA5   Base(2)
12.2(44)SG     Base(2)
12.2(31)SGA6   Base(2)
12.2(31)SGA7   Base(2)
12.2(46)SG     Base(2)
12.2(44)SG1    Base(2)
12.2(31)SGA8   Base(2)
12.2(50)SG     Dynamic(0)
12.2(31)SGA9   Base(2)
12.2(50)SG1    Dynamic(0)
12.2(50)SG2    Dynamic(0)
12.2(52)SG     Comp(3)

```

Dynamic(0) was introduced in Cisco IOS Release 12.2(50)SG with the Dynamic Image Version Compatibility (DIVC) feature. With DIVC, we store Dynamic(0) rather than Incomp(1), Base(2), or Comp(3), and determine compatibility during run-time when two different DIVC-capable images are running in the active and standby supervisor engines during ISSU.

For Catalyst 4500 switches, a value of Dynamic(0) in the stored compatibility-matrix normally results in Base(2) or Comp(3) upon run-time negotiation between the two images; as of today, you never observe Incomp(1) as long as the other image name is present in the stored compatibility-matrix.