



Configuring SPAN and RSPAN

This chapter describes how to configure Switched Port Analyzer (SPAN) and Remote SPAN (RSPAN) on the Catalyst 3750 switch. Unless otherwise noted, the term *switch* refers to a standalone switch and a switch stack.



Note

For complete syntax and usage information for the commands used in this chapter, refer to the command reference for this release.

This chapter consists of these sections:

- [Understanding SPAN and RSPAN, page 22-1](#)
- [Configuring SPAN and RSPAN, page 22-10](#)
- [Displaying SPAN and RSPAN Status, page 22-24](#)

Understanding SPAN and RSPAN

You can analyze network traffic passing through ports or VLANs by using SPAN or RSPAN to send a copy of the traffic to another port on the switch or on another switch that has been connected to a network analyzer or other monitoring or security device. SPAN copies (or mirrors) traffic received or sent (or both) on source ports or source VLANs to a destination port for analysis. SPAN does not affect the switching of network traffic on the source ports or VLANs. You must dedicate the destination port for SPAN use. Except for traffic that is required for the SPAN or RSPAN session, destination ports do not receive or forward traffic.

Only traffic that enters or leaves source ports or traffic that enters or leaves source VLANs can be monitored by using SPAN; traffic routed to a source VLAN cannot be monitored. For example, if incoming traffic is being monitored, traffic that gets routed from another VLAN to the source VLAN cannot be monitored; however, traffic that is received on the source VLAN and routed to another VLAN can be monitored.

You can use the SPAN or RSPAN destination port to inject traffic from a network security device. For example, if you connect a Cisco Intrusion Detection System (IDS) sensor appliance to a destination port, the IDS device can send TCP reset packets to close down the TCP session of a suspected attacker.

This section includes these topics:

- [Local SPAN, page 22-2](#)
- [Remote SPAN, page 22-3](#)
- [SPAN and RSPAN Concepts and Terminology, page 22-4](#)
- [SPAN and RSPAN Interaction with Other Features, page 22-9](#)
- [SPAN and RSPAN and Switch Stacks, page 22-10](#)

Local SPAN

Local SPAN supports a SPAN session entirely within one switch; all source ports or source VLANs and destination ports reside in the same switch or switch stack. Local SPAN copies traffic from one or more source ports in any VLAN or from one or more VLANs to a destination port for analysis. For example, in [Figure 22-1](#), all traffic on port 5 (the source port) is mirrored to port 10 (the destination port). A network analyzer on port 10 receives all network traffic from port 5 without being physically attached to port 5.

Figure 22-1 Example of Local SPAN Configuration on a Single Switch

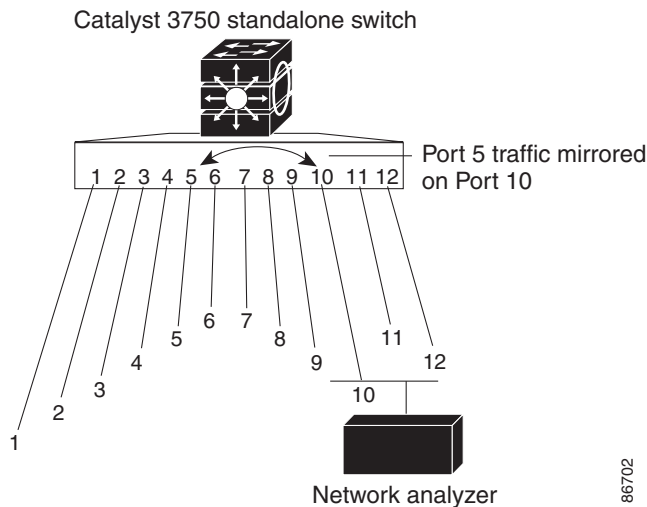

[Figure 22-2](#) is an example of a local SPAN in a switch stack, where the source and destination ports reside on different stack members.

Figure 22-2 Example of Local SPAN Configuration on a Switch Stack

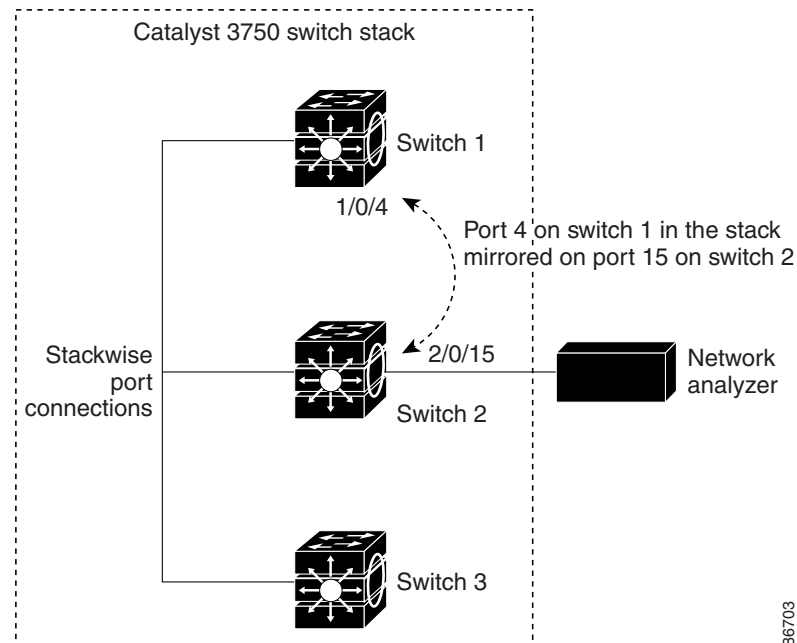

Remote SPAN

RSPAN supports source ports, source VLANs, and destination ports on different switches (or different switch stacks), enabling remote monitoring of multiple switches across your network as shown in [Figure 22-3](#). The traffic for each RSPAN session is carried over a user-specified RSPAN VLAN that is dedicated for that RSPAN session in all participating switches. The RSPAN traffic from the source ports or VLANs is copied into the RSPAN VLAN and forwarded over trunk ports carrying the RSPAN VLAN to a destination session monitoring the RSPAN VLAN. Each RSPAN source switch must have either ports or VLANs as RSPAN sources. The destination is always a physical port.

Figure 22-3 Example of RSPAN Configuration

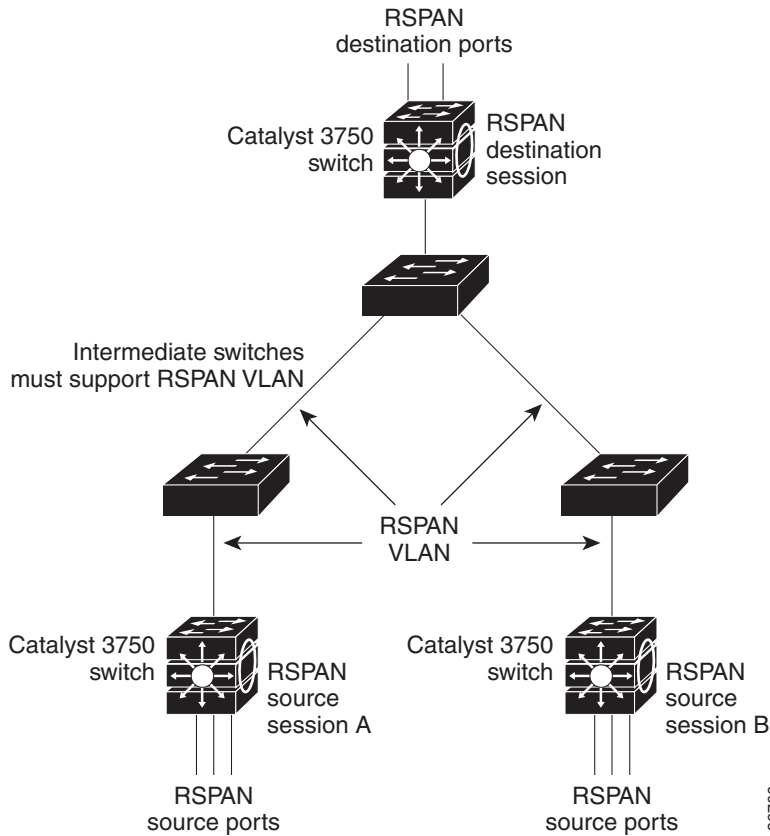

86766

SPAN and RSPAN Concepts and Terminology

This section describes concepts and terminology associated with SPAN and RSPAN configuration.

SPAN Sessions

SPAN sessions (local or remote) allow you to monitor traffic on one or more ports, or one or more VLANs, and send the monitored traffic to one or more destination ports.

A local SPAN session is an association of a destination port with source ports or source VLANs, all on a single network device. Local SPAN does not have separate source and destination sessions. Local SPAN sessions gather a set of ingress and egress packets specified by the user and form them into a stream of SPAN data, which is directed to the destination port.

RSPAN consists of at least one RSPAN source session, an RSPAN VLAN, and at least one RSPAN destination session. You separately configure RSPAN source sessions and RSPAN destination sessions on different network devices. To configure an RSPAN source session on a device, you associate a set of source ports or source VLANs with an RSPAN VLAN. The output of this session is the stream of SPAN packets that are sent to the RSPAN VLAN. To configure an RSPAN destination session on another device, you associate the destination port with the RSPAN VLAN. The destination session collects all RSPAN VLAN traffic and sends it out the RSPAN destination port.

An RSPAN source session is very similar to a local SPAN session, except for where the packet stream is directed. In an RSPAN source session, SPAN packets are relabeled with the RSPAN VLAN ID and directed over normal trunk ports to the destination switch.

An RSPAN destination session takes all packets received on the RSPAN VLAN, strips off the VLAN tagging, and presents them on the destination port. Its purpose is to present a copy of all RSPAN VLAN packets (except Layer 2 control packets) to the user for analysis.

There can be more than one source session and more than one destination session active in the same RSPAN VLAN. There can also be intermediate switches separating the RSPAN source and destination sessions. These switches need not be capable of running RSPAN, but they must handle the requirements of the RSPAN VLAN (see the “[RSPAN VLAN](#)” section on page 22-9).

Traffic monitoring in a SPAN session has these restrictions:

- Sources can be ports or VLANs, but you cannot mix source ports and source VLANs in the same session.
- The switch supports up to two source sessions; you can run both a local SPAN and an RSPAN source session in the same switch stack. The switch stack supports a total of 66 source and RSPAN destination sessions.
- You can have multiple destination ports in a SPAN session, but no more than 64 destination ports per switch stack.
- You can configure two separate SPAN or RSPAN source sessions with separate or overlapping sets of SPAN source ports and VLANs. Both switched and routed ports can be configured as SPAN sources and destinations.
- SPAN sessions do not interfere with the normal operation of the switch. However, an oversubscribed SPAN destination, for example, a 10-Mbps port monitoring a 100-Mbps port, can result in dropped or lost packets.
- When RSPAN is enabled, each packet being monitored is transmitted twice, once as normal traffic and once as a monitored packet. Therefore monitoring a large number of ports or VLANs could potentially generate large amounts of network traffic.
- You can configure SPAN sessions on disabled ports; however, a SPAN session does not become active unless you enable the destination port and at least one source port or VLAN for that session.
- The switch does not support a combination of local SPAN and RSPAN in a single session. That is, an RSPAN source session cannot have a local destination port, an RSPAN destination session cannot have a local source port, and an RSPAN destination session and an RSPAN source session that are using the same RSPAN VLAN cannot run on the same switch stack.

Monitored Traffic

SPAN sessions can monitor these traffic types:

- Receive (Rx) SPAN—The goal of receive (or ingress) SPAN is to monitor as much as possible all the packets received by the source interface or VLAN before any modification or processing is performed by the switch. A copy of each packet received by the source is sent to the destination port for that SPAN session.

Packets that are modified because of routing or quality of service (QoS)—for example, modified Differentiated Services Code Point (DSCP)—are copied before modification.

Features that can cause a packet to be dropped during receive processing have no effect on ingress SPAN; the destination port receives a copy of the packet even if the actual incoming packet is dropped. These features include IP standard and extended input access control lists (ACLs), ingress QoS policing, VLAN ACLs and egress QoS policing.

- **Transmit (Tx) SPAN**—The goal of transmit (or egress) SPAN is to monitor as much as possible all the packets sent by the source interface after all modification and processing is performed by the switch. A copy of each packet sent by the source is sent to the destination port for that SPAN session. The copy is provided after the packet is modified.

Packets that are modified because of routing—for example, with modified time-to-live (TTL), MAC-address, or QoS values—are duplicated (with the modifications) at the destination port.

Features that can cause a packet to be dropped during transmit processing also affect the duplicated copy for SPAN. These features include IP standard and extended output ACLs and egress QoS policing.

- **Both**—In a SPAN session, you can also monitor a port or VLAN for both received and sent packets. This is the default.

The default configuration for local SPAN session ports is to send all packets untagged. SPAN also does not normally monitor bridge protocol data unit (BPDU) packets and Layer 2 protocols, such as Cisco Discovery Protocol (CDP), VLAN Trunk Protocol (VTP), Dynamic Trunking Protocol (DTP), Spanning Tree Protocol (STP), and Port Aggregation Protocol (PAgP). However, when you enter the **encapsulation replicate** keywords when configuring a destination port, these changes occur:

- Packets are sent on the destination port with the same encapsulation—untagged, IEEE 802.1Q, or Inter-Switch Link (ISL)—that they had on the source port.
- Packets of all types, including BPDU and Layer 2 protocol packets are monitored.

Therefore, a local SPAN session with **encapsulation replicate** enabled can have a mixture of untagged, 802.1Q, and ISL tagged packets appear on the destination port.

Switch congestion can cause packets to be dropped at ingress source ports, egress source ports, or SPAN destination ports. In general, these characteristics are independent of one another. For example:

- A packet might be forwarded normally but dropped from monitoring due to an oversubscribed SPAN destination port.
- An ingress packet might be dropped from normal forwarding, but still appear on the SPAN destination port.
- An egress packet dropped because of switch congestion is also dropped from egress SPAN.

In some SPAN configurations, multiple copies of the same source packet are sent to the SPAN destination port. For example, a bidirectional (both Rx and Tx) SPAN session is configured for the Rx monitor on port A and Tx monitor on port B. If a packet enters the switch through port A and is switched to port B, both incoming and outgoing packets are sent to the destination port. Both packets are the same (unless a Layer-3 rewrite occurs, in which case the packets are different because of the packet modification).

Source Ports

A source port (also called a *monitored port*) is a switched or routed port that you monitor for network traffic analysis. In a local SPAN session or RSPAN source session, you can monitor source ports or VLANs for traffic in one or both directions. The switch supports any number of source ports (up to the maximum number of available ports on the switch) and any number of source VLANs (up to the maximum number of VLANs supported). However, the switch supports a maximum of two sessions (local or RSPAN) with source ports or VLANs and you cannot mix ports and VLANs in a single session.

A source port has these characteristics:

- It can be monitored in multiple SPAN sessions.
- Each source port can be configured with a direction (ingress, egress, or both) to monitor.

- It can be any port type (for example, EtherChannel, Fast Ethernet, Gigabit Ethernet, and so forth).
- For EtherChannel sources, you can monitor traffic for the entire EtherChannel or individually on a physical port as it participates in the port channel.
- It can be an access port, trunk port, routed port, or voice VLAN port.
- It cannot be a destination port.
- Source ports can be in the same or different VLANs.
- You can monitor multiple source ports in a single session.

Source VLANs

VLAN-based SPAN (VSPAN) is the monitoring of the network traffic in one or more VLANs. The SPAN or RSPAN source interface in VSPAN is a VLAN ID and traffic is monitored on all the ports for that VLAN.

VSPAN has these characteristics:

- All active ports in the source VLAN are included as source ports and can be monitored in either or both directions.
- On a given port, only traffic on the monitored VLAN is sent to the destination port.
- If a destination port belongs to a source VLAN, it is excluded from the source list and is not monitored.
- If ports are added to or removed from the source VLANs, the traffic on the source VLAN received by those ports is added to or removed from the sources being monitored.
- You cannot use filter VLANs in the same session with VLAN sources.
- You can monitor only Ethernet VLANs.

VLAN Filtering

When you monitor a trunk port as a source port, by default, all VLANs active on the trunk are monitored. You can limit SPAN traffic monitoring on trunk source ports to specific VLANs by using VLAN filtering.

- VLAN filtering applies only to trunk ports or to voice VLAN ports.
- VLAN filtering applies only to port-based sessions and is not allowed in sessions with VLAN sources.
- When a VLAN filter list is specified, only those VLANs in the list are monitored on trunk ports or on voice VLAN access ports.
- SPAN traffic coming from other port types is not affected by VLAN filtering; that is, all VLANs are allowed on other ports.
- VLAN filtering affects only traffic forwarded to the destination SPAN port and does not affect the switching of normal traffic.

Destination Port

Each local SPAN session or RSPAN destination session must have a destination port (also called a *monitoring port*) that receives a copy of traffic from the source ports or VLANs and sends the SPAN packets to the user, usually a network analyzer.

A destination port has these characteristics:

- For a local SPAN session, the destination port must reside on the same switch stack as the source port. For an RSPAN session, it is located on the switch containing the RSPAN destination session. There is no destination port on a switch or switch stack running only an RSPAN source session.
- When a port is configured as a SPAN destination port, the configuration overwrites the original port configuration. When the SPAN destination configuration is removed, the port reverts to its previous configuration. If a configuration change is made to the port while it is acting as a SPAN destination port, the change does not take effect until the SPAN destination configuration had been removed.
- If the port was in an EtherChannel group, it is removed from the group while it is a destination port. If it was a routed port, it is no longer a routed port.
- It can be any Ethernet physical port.
- It cannot be a secure port.
- It cannot be a source port.
- It cannot be an EtherChannel group or a VLAN.
- It can participate in only one SPAN session at a time (a destination port in one SPAN session cannot be a destination port for a second SPAN session).
- When it is active, incoming traffic is disabled. The port does not transmit any traffic except that required for the SPAN session. Incoming traffic is never learned or forwarded on a destination port.
- If ingress traffic forwarding is enabled for a network security device, the destination port forwards traffic at Layer 2.
- It does not participate in any of the Layer 2 protocols (STP, VTP, CDP, DTP, PagP).
- A destination port that belongs to a source VLAN of any SPAN session is excluded from the source list and is not monitored.
- The maximum number of destination ports in a switch stack is 64.

Local SPAN and RSPAN destination ports behave differently regarding VLAN tagging and encapsulation:

- For local SPAN, if the **encapsulation replicate** keywords are specified for the destination port, these packets appear with the original encapsulation (untagged, ISL, or 802.1Q). If these keywords are not specified, packets appear in the untagged format. Therefore, the output of a local SPAN session with **encapsulation replicate** enabled can contain a mixture of untagged, 802.1Q, or ISL tagged packets.
- For RSPAN, the original VLAN ID is lost because it is overwritten by the RSPAN VLAN identification. Therefore, all packets appear on the destination port as untagged.

RSPAN VLAN

The RSPAN VLAN carries SPAN traffic between RSPAN source and destination sessions. It has these special characteristics:

- All traffic in the RSPAN VLAN is always flooded.
- No MAC address learning occurs on the RSPAN VLAN.
- RSPAN VLAN traffic only flows on trunk ports.
- RSPAN VLANs must be configured in VLAN configuration mode by using the **remote-span** VLAN configuration mode command.
- STP can run on RSPAN VLAN trunks but not on SPAN destination ports.

For VLANs 1 to 1005 that are visible to VLAN Trunking Protocol (VTP), the VLAN ID and its associated RSPAN characteristic are propagated by VTP. If you assign an RSPAN VLAN ID in the extended VLAN range (1006 to 4094), you must manually configure all intermediate switches.

It is normal to have multiple RSPAN VLANs in a network at the same time with each RSPAN VLAN defining a network-wide RSPAN session. That is, multiple RSPAN source sessions anywhere in the network can contribute packets to the RSPAN session. It is also possible to have multiple RSPAN destination sessions throughout the network, monitoring the same RSPAN VLAN and presenting traffic to the user. The RSPAN VLAN ID separates the sessions.

SPAN and RSPAN Interaction with Other Features

SPAN interacts with these features:

- Routing—SPAN does not monitor routed traffic. VSPAN only monitors traffic that enters or exits the switch, not traffic that is routed between VLANs. For example, if a VLAN is being Rx-monitored and the switch routes traffic from another VLAN to the monitored VLAN, that traffic is not monitored and not received on the SPAN destination port.
- Spanning Tree Protocol (STP)—A destination port does not participate in STP while its SPAN or RSPAN session is active. The destination port can participate in STP after the SPAN or RSPAN session is disabled. On a source port, SPAN does not affect the STP status. STP can be active on trunk ports carrying an RSPAN VLAN.
- Cisco Discovery Protocol (CDP)—A SPAN destination port does not participate in CDP while the SPAN session is active. After the SPAN session is disabled, the port again participates in CDP.
- VLAN Trunking Protocol (VTP)—You can use VTP to prune an RSPAN VLAN between switches.
- VLAN and trunking—You can modify VLAN membership or trunk settings for source or destination ports at any time. However, changes in VLAN membership or trunk settings for a destination port do not take effect until you remove the SPAN destination configuration. Changes in VLAN membership or trunk settings for a source port immediately take effect, and the respective SPAN sessions automatically adjust accordingly.
- EtherChannel—You can configure an EtherChannel group as a source port but not as a SPAN destination port. When a group is configured as a SPAN source, the entire group is monitored.

If a physical port is added to a monitored EtherChannel group, the new port is added to the SPAN source port list. If a port is removed from a monitored EtherChannel group, it is automatically removed from the source port list. If the port is the only port in the EtherChannel group, because there are no longer any ports in the group, there is no data to monitor.

A physical port that belongs to an EtherChannel group can be configured as a SPAN source port and still be a part of the EtherChannel. In this case, data from the physical port is monitored as it participates in the EtherChannel. However, if a physical port that belongs to an EtherChannel group is configured as a SPAN destination, it is removed from the group. After the port is removed from the SPAN session, it rejoins the EtherChannel group. Ports removed from an EtherChannel group remain members of the group, but they are in the *inactive* or *standalone* state.

If a physical port that belongs to an EtherChannel group is a destination port and the EtherChannel group is a source, the port is removed from the EtherChannel group and from the list of monitored ports.

- Multicast traffic can be monitored. For egress and ingress port monitoring, only a single unedited packet is sent to the SPAN destination port. It does not reflect the number of times the multicast packet is sent.
- A secure port cannot be a SPAN destination port.

For SPAN sessions, do not enable port security on ports with monitored egress when ingress forwarding is enabled on the destination port. For RSPAN source sessions, do not enable port security on any ports with monitored egress.

- An 802.1X port can be a SPAN source port. You can enable 802.1X on a port that is a SPAN destination port; however, 802.1X is disabled until the port is removed as a SPAN destination.

For SPAN sessions, do not enable 802.1X on ports with monitored egress when ingress forwarding is enabled on the destination port. For RSPAN source sessions, do not enable 802.1X on any ports that are egress monitored.

SPAN and RSPAN and Switch Stacks

Because the stack of switches is treated as one logical switch, local SPAN source ports and destination ports can be in different switches in the stack. Therefore, the addition or deletion of switches in the stack can affect a local SPAN session, as well as an RSPAN source or destination session. An active session can become inactive when a switch is removed from the stack or an inactive session can become active when a switch is added to the stack.

For more information about switch stacks, see [Chapter 5, “Managing Switch Stacks.”](#)

Configuring SPAN and RSPAN

This section describes how to configure SPAN on your switch. It contains this configuration information:

- [Default SPAN and RSPAN Configuration, page 22-11](#)
- [Configuring Local SPAN, page 22-11](#)
- [Configuring RSPAN, page 22-17](#)

Default SPAN and RSPAN Configuration

Table 22-1 shows the default SPAN and RSPAN configuration.

Table 22-1 Default SPAN and RSPAN Configuration

Feature	Default Setting
SPAN state (SPAN and RSPAN)	Disabled.
Source port traffic to monitor	Both received and sent traffic (both).
Encapsulation type (destination port)	Native form (untagged packets).
Ingress forwarding (destination port)	Disabled
VLAN filtering	On a trunk interface used as a source port, all VLANs are monitored.
RSPAN VLANs	None configured.

Configuring Local SPAN

This section describes how to configure Local SPAN on your switch. It contains this configuration information:

- [SPAN Configuration Guidelines, page 22-11](#)
- [Creating a Local SPAN Session, page 22-12](#)
- [Creating a Local SPAN Session and Configuring Ingress Traffic, page 22-14](#)
- [Specifying VLANs to Filter, page 22-16](#)

SPAN Configuration Guidelines

Follow these guidelines when configuring SPAN:

- You can configure a total of two local SPAN sessions or RSPAN source sessions on each switch stack. You can have a total of 66 SPAN sessions (local, RSPAN source, and RSPAN destination) on a switch stack.
- If a 10-Gigabit Ethernet module port on WS-C3750G-16TD is configured as a SPAN or RSPAN destination port, its link rate decreases. Traffic mirrored in this way is limited to 1G.
- For SPAN sources, you can monitor traffic for a single port or VLAN or a series or range of ports or VLANs for each session. You cannot mix source ports and source VLANs within a single SPAN session.
- The destination port cannot be a source port; a source port cannot be a destination port.
- You cannot have two SPAN sessions using the same destination port.
- When you configure a switch port as a SPAN destination port, it is no longer a normal switch port; only monitored traffic passes through the SPAN destination port.
- Entering SPAN configuration commands does not remove previously configured SPAN parameters. You must enter the **no monitor session** {*session_number* | **all** | **local** | **remote**} global configuration command to delete configured SPAN parameters.

- For local SPAN, outgoing packets through the SPAN destination port carry the original encapsulation headers—untagged, ISL, or IEEE 802.1Q— if the **encapsulation replicate** keywords are specified. If the keywords are not specified, the packets are sent in native form. For RSPAN destination ports, outgoing packets are not tagged.
- You can configure a disabled port to be a source or destination port, but the SPAN function does not start until the destination port and at least one source port or source VLAN are enabled.
- You can limit SPAN traffic to specific VLANs by using the **filter vlan** keyword. If a trunk port is being monitored, only traffic on the VLANs specified with this keyword is monitored. By default, all VLANs are monitored on a trunk port.
- You cannot mix source VLANs and filter VLANs within a single SPAN session.

Creating a Local SPAN Session

Beginning in privileged EXEC mode, follow these steps to create a SPAN session and specify the source (monitored) ports or VLANs and the destination (monitoring) ports:

	Command	Purpose
Step 1	configure terminal	Enter global configuration mode.
Step 2	no monitor session { <i>session_number</i> all local remote }	Remove any existing SPAN configuration for the session. For <i>session_number</i> , the range is from 1 to 66. Specify all to remove all SPAN sessions, local to remove all local sessions, or remote to remove all remote SPAN sessions.

Command	Purpose
<p>Step 3 monitor session <i>session_number</i> source {interface <i>interface-id</i> vlan <i>vlan-id</i>} [, -] [both rx tx]</p>	<p>Specify the SPAN session and the source port (monitored port). For <i>session_number</i>, the range is from 1 to 66. For <i>interface-id</i>, specify the source port or source VLAN to monitor.</p> <ul style="list-style-type: none"> For source <i>interface-id</i>, specify the source port to monitor. Valid interfaces include physical interfaces and port-channel logical interfaces (port-channel <i>port-channel-number</i>). Valid port channel numbers are 1 to 12. For <i>vlan-id</i>, specify the source VLAN to monitor. The range is 1 to 4094 (excluding the RSPAN VLAN). <p>Note A single session can include multiple sources (ports or VLANs), defined in a series of commands, but you cannot combine source ports and source VLANs in one session.</p> <p>(Optional) [, -] Specify a series or range of interfaces. Enter a space before and after the comma; enter a space before and after the hyphen.</p> <p>(Optional) Specify the direction of traffic to monitor. If you do not specify a traffic direction, the SPAN monitors both sent and received traffic.</p> <ul style="list-style-type: none"> both—Monitor both received and sent traffic. This is the default. rx—Monitor received traffic. tx—Monitor sent traffic. <p>Note You can use the monitor session <i>session_number</i> source command multiple times to configure multiple source ports.</p>
<p>Step 4 monitor session <i>session_number</i> destination {interface <i>interface-id</i> [, -] [encapsulation replicate]}</p>	<p>Specify the SPAN session and the destination port (monitoring port). For <i>session_number</i>, specify the session number entered in step 3.</p> <p>Note For local SPAN, you must use the same session number for the source and destination interfaces.</p> <p>For <i>interface-id</i>, specify the destination port. The destination interface must be a physical port; it cannot be an EtherChannel, and it cannot be a VLAN.</p> <p>(Optional) [, -] Specify a series or range of interfaces. Enter a space before and after the comma; enter a space before and after the hyphen.</p> <p>(Optional) Enter encapsulation replicate to specify that the destination interface replicates the source interface encapsulation method. If not selected, the default is to send packets in native form (untagged).</p> <p>Note You can use monitor session <i>session_number</i> destination command multiple times to configure multiple destination ports.</p>
<p>Step 5 end</p>	<p>Return to privileged EXEC mode.</p>

	Command	Purpose
Step 6	<code>show monitor [session session_number]</code> <code>show running-config</code>	Verify the configuration.
Step 7	<code>copy running-config startup-config</code>	(Optional) Save the configuration in the configuration file.

To delete a SPAN session, use the **no monitor session session_number** global configuration command. To remove a source or destination port or VLAN from the SPAN session, use the **no monitor session session_number source {interface interface-id | vlan vlan-id}** global configuration command or the **no monitor session session_number destination interface interface-id** global configuration command. For destination interfaces, the **encapsulation replicate** keywords are ignored with the **no** form of the command.

This example shows how to set up SPAN session 1, for monitoring source port traffic to a destination port. First, any existing SPAN configuration for session 1 is deleted, and then bidirectional traffic is mirrored from source Gigabit Ethernet port 0/1 to destination Gigabit Ethernet port 0/10 on switch 1, retaining the encapsulation method.

```
Switch(config)# no monitor session 1
Switch(config)# monitor session 1 source interface gigabitethernet1/0/1
Switch(config)# monitor session 1 destination interface gigabitethernet1/0/10
encapsulation replicate
Switch(config)# end
```

This example shows how to remove port 0/1 on switch 1 as a SPAN source for SPAN session 1:

```
Switch(config)# no monitor session 1 source interface gigabitethernet1/0/1
Switch(config)# end
```

This example shows how to disable received traffic monitoring on port 0/1 on switch 1, which was configured for bidirectional monitoring:

```
Switch(config)# no monitor session 1 source interface gigabitethernet1/0/1 rx
```

The monitoring of traffic received on port 0/1 is disabled, but traffic sent from this port continues to be monitored.

This example shows how to remove any existing configuration on SPAN session 2, configure SPAN session 2 to monitor received traffic on all ports belonging to VLANs 1 through 3, and send it to destination Gigabit Ethernet port 0/2 on switch 1. The configuration is then modified to also monitor all traffic on all ports belonging to VLAN 10.

```
Switch(config)# no monitor session 2
Switch(config)# monitor session 2 source vlan 1 - 3 rx
Switch(config)# monitor session 2 destination interface gigabitethernet1/0/2
Switch(config)# monitor session 2 source vlan 10
Switch(config)# end
```

Creating a Local SPAN Session and Configuring Ingress Traffic

Beginning in privileged EXEC mode, follow these steps to create a SPAN session, to specify the source ports or VLANs and the destination ports, and to enable ingress traffic on the destination port for a network security device (such as a Cisco IDS Sensor Appliance).



Note

Refer to the [“Creating a Local SPAN Session”](#) section on page 22-12 for details about the keywords not related to ingress traffic.

	Command	Purpose
Step 1	configure terminal	Enter global configuration mode.
Step 2	no monitor session { <i>session_number</i> all local remote }	Remove any existing SPAN configuration for the session.
Step 3	monitor session <i>session_number</i> source { interface <i>interface-id</i> vlan <i>vlan-id</i> } [, -] [both rx tx]	Specify the SPAN session and the source port (monitored port).
Step 4	monitor session <i>session_number</i> destination { interface <i>interface-id</i> [, -] [encapsulation replicate] [ingress { dot1q <i>vlan</i> <i>vlan-id</i> isl untagged <i>vlan</i> <i>vlan-id</i> vlan <i>vlan-id</i> }}}	<p>Specify the SPAN session, the destination port, the packet encapsulation, and the ingress VLAN and encapsulation.</p> <p>For <i>session_number</i>, specify the session number entered in step 3.</p> <p>For <i>interface-id</i>, specify the destination port. The destination interface must be a physical port; it cannot be an EtherChannel, and it cannot be a VLAN.</p> <p>(Optional) [, -] Specify a series or range of interfaces. Enter a space before and after the comma or hyphen.</p> <p>(Optional) Enter encapsulation replicate to specify that the destination interface replicates the source interface encapsulation method. If not selected, the default is to send packets in native form (untagged).</p> <p>Enter ingress with keywords to enable ingress traffic forwarding on the destination port and specify the encapsulation type:</p> <ul style="list-style-type: none"> • dot1q <i>vlan</i> <i>vlan-id</i>—Forward ingress packets with 802.1Q encapsulation with the specified VLAN as the default VLAN. • isl—Forward ingress packets with ISL encapsulation. • untagged <i>vlan</i> <i>vlan-id</i> or vlan <i>vlan-id</i>—Forward ingress packets with untagged encapsulation type with the specified VLAN as the default VLAN.
Step 5	end	Return to privileged EXEC mode.
Step 6	show monitor [session <i>session_number</i>] show running-config	Verify the configuration.
Step 7	copy running-config startup-config	(Optional) Save the configuration in the configuration file.

To delete a SPAN session, use the **no monitor session** *session_number* global configuration command. To remove a source or destination port or VLAN from the SPAN session, use the **no monitor session** *session_number* **source** {**interface** *interface-id* | **vlan** *vlan-id*} global configuration command or the **no monitor session** *session_number* **destination** **interface** *interface-id* global configuration command. For destination interfaces, the encapsulation and ingress options are ignored with the **no** form of the command.

This example shows how to remove any existing configuration on SPAN session 2, configure SPAN session 2 to monitor received traffic on all source Gigabit Ethernet source port 0/1 on switch 1, and send it to destination Gigabit Ethernet port 0/2 on switch 1 with the same egress encapsulation type as the source port, and enable ingress forwarding with 802.1Q encapsulation and VLAN 6 as the default ingress VLAN.

```
Switch(config)# no monitor session 2
```

```
Switch(config)# monitor session 2 source gigabitethernet1/0/2 rx
Switch(config)# monitor session 2 destination interface gigabitethernet1/0/2 encapsulation
replicate ingress dot1q vlan 6
Switch(config)# end
```

Specifying VLANs to Filter

Beginning in privileged EXEC mode, follow these steps to limit SPAN source traffic to specific VLANs:

	Command	Purpose
Step 1	configure terminal	Enter global configuration mode.
Step 2	no monitor session { <i>session_number</i> all local remote }	Remove any existing SPAN configuration for the session. For <i>session_number</i> , the range is from 1 to 66. Specify all to remove all SPAN sessions, local to remove all local sessions, or remote to remove all remote SPAN sessions.
Step 3	monitor session <i>session_number</i> source interface <i>interface-id</i>	Specify the characteristics of the source port (monitored port) and SPAN session. For <i>session_number</i> , the range is from 1 to 66. For <i>interface-id</i> , specify the source port to monitor. The interface specified must already be configured as a trunk port.
Step 4	monitor session <i>session_number</i> filter vlan <i>vlan-id</i> [, -]	Limit the SPAN source traffic to specific VLANs. For <i>session_number</i> , enter the session number specified in Step 3. For <i>vlan-id</i> , the range is 1 to 4094. (Optional) Use a comma (,) to specify a series of VLANs, or use a hyphen (-) to specify a range of VLANs. Enter a space before and after the comma; enter a space before and after the hyphen.
Step 5	monitor session <i>session_number</i> destination { interface <i>interface-id</i> [, -] [encapsulation replicate] }	Specify the SPAN session and the destination port (monitoring port). For <i>session_number</i> , specify the session number entered in step 3. For <i>interface-id</i> , specify the destination port. The destination interface must be a physical port; it cannot be an EtherChannel, and it cannot be a VLAN. (Optional) [, -] Specify a series or range of interfaces. Enter a space before and after the comma; enter a space before and after the hyphen. (Optional) Enter encapsulation replicate to specify that the destination interface replicates the source interface encapsulation method. If not selected, the default is to send packets in native form (untagged).
Step 6	end	Return to privileged EXEC mode.
Step 7	show monitor [session <i>session_number</i>] show running-config	Verify the configuration.
Step 8	copy running-config startup-config	(Optional) Save the configuration in the configuration file.

To monitor all VLANs on the trunk port, use the **no monitor session** *session_number* **filter** global configuration command.

This example shows how to remove any existing configuration on SPAN session 2, configure SPAN session 2 to monitor traffic received on Gigabit Ethernet trunk port 0/4 on switch 1, and send traffic for only VLANs 1 through 5 and 9 to destination Gigabit Ethernet port 0/8 on switch 1.

```
Switch(config)# no monitor session 2
Switch(config)# monitor session 2 source interface gigabitethernet1/0/4 rx
Switch(config)# monitor session 2 filter vlan 1 - 5 , 9
Switch(config)# monitor session 2 destination interface gigabitethernet1/0/8
Switch(config)# end
```

Configuring RSPAN

This section describes how to configure RSPAN on your switch. It contains this configuration information:

- [RSPAN Configuration Guidelines, page 22-17](#)
- [Configuring a VLAN as an RSPAN VLAN, page 22-18](#)
- [Creating an RSPAN Source Session, page 22-19](#)
- [Creating an RSPAN Destination Session, page 22-20](#)
- [Creating an RSPAN Destination Session, page 22-20](#)
- [Specifying VLANs to Filter, page 22-23](#)

RSPAN Configuration Guidelines

Follow these guidelines when configuring RSPAN:

- All the items in the “[SPAN Configuration Guidelines](#)” section on [page 22-11](#) apply to RSPAN.
- As RSPAN VLANs have special properties, you should reserve a few VLANs across your network for use as RSPAN VLANs; do not assign access ports to these VLANs.
- You can apply an output access control list (ACL) to RSPAN traffic to selectively filter or monitor specific packets. Specify these ACLs on the RSPAN VLAN in the RSPAN source switches.
- For RSPAN configuration, you can distribute the source ports and the destination ports across multiple switches in your network.
- RSPAN does not support BPDU packet monitoring or other Layer 2 switch protocols.
- The RSPAN VLAN is configured only on trunk ports and not on access ports. To avoid unwanted traffic in RSPAN VLANs, make sure that the VLAN remote-span feature is supported in all the participating switches.
- Access ports (including voice VLAN ports) on the RSPAN VLAN are put in the inactive state.
- RSPAN VLANs are included as sources for port-based RSPAN sessions when source trunk ports have active RSPAN VLANs. RSPAN VLANs can also be sources in SPAN sessions. However, since the switch does not monitor spanned traffic, it does not support egress spanning of packets on any RSPAN VLAN identified as the destination of an RSPAN source session on the switch.
- You can configure any VLAN as an RSPAN VLAN as long as these conditions are met:
 - The same RSPAN VLAN is used for an RSPAN session in all the switches.
 - All participating switches support RSPAN.

- We recommend that you configure an RSPAN VLAN before you configure an RSPAN source or a destination session.
- If you enable VTP and VTP pruning, RSPAN traffic is pruned in the trunks to prevent the unwanted flooding of RSPAN traffic across the network for VLAN IDs that are lower than 1005.

Configuring a VLAN as an RSPAN VLAN

First create a new VLAN to be the RSPAN VLAN for the RSPAN session. You must create the RSPAN VLAN in all switches that will participate in RSPAN. If the RSPAN VLAN-ID is in the normal range (lower than 1005) and VTP is enabled in the network, you can create the RSPAN VLAN in one switch, and VTP propagates it to the other switches in the VTP domain. For extended-range VLANs (greater than 1005), you must configure RSPAN VLAN on both source and destination switches and any intermediate switches.

Use VTP pruning to get an efficient flow of RSPAN traffic, or manually delete the RSPAN VLAN from all trunks that do not need to carry the RSPAN traffic.

Beginning in privileged EXEC mode, follow these steps to create an RSPAN VLAN:

	Command	Purpose
Step 1	configure terminal	Enter global configuration mode.
Step 2	vlan <i>vlan-id</i>	Enter a VLAN ID to create a VLAN, or enter the VLAN ID of an existing VLAN, and enter VLAN configuration mode. The range is from 2 to 1001 and from 1006 to 4094. Note The RSPAN VLAN cannot be VLAN 1 (the default VLAN) or VLAN IDs 1002 through 1005 (reserved for Token Ring and FDDI VLANs).
Step 3	remote-span	Configure the VLAN as an RSPAN VLAN.
Step 4	end	Return to privileged EXEC mode.
Step 5	copy running-config startup-config	(Optional) Save the configuration in the configuration file.

To remove the remote SPAN characteristic from a VLAN and convert it back to a normal VLAN, use the **no remote-span** VLAN configuration command.

This example shows how to create RSPAN VLAN 901.

```
Switch(config)# vlan 901
Switch(config-vlan)# remote span
Switch(config-vlan)# end
```

Creating an RSPAN Source Session

Beginning in privileged EXEC mode, follow these steps to start an RSPAN source session and to specify the monitored source and the destination RSPAN VLAN:

	Command	Purpose
Step 1	configure terminal	Enter global configuration mode.
Step 2	no monitor session { <i>session_number</i> all local remote }	Remove any existing RSPAN configuration for the session. For <i>session_number</i> , the range is from 1 to 66. Specify all to remove all RSPAN sessions, local to remove all local sessions, or remote to remove all remote SPAN sessions.
Step 3	monitor session <i>session_number</i> source { interface <i>interface-id</i> vlan <i>vlan-id</i> } [, -] [both rx tx]	Specify the RSPAN session and the source port (monitored port). For <i>session_number</i> , the range is from 1 to 66. Enter a source port or source VLAN for the RSPAN session: <ul style="list-style-type: none"> For <i>interface-id</i>, specify the source port to monitor. Valid interfaces include physical interfaces and port-channel logical interfaces (port-channel <i>port-channel-number</i>). Valid port channel numbers are 1 to 12. For <i>vlan-id</i>, specify the source VLAN to monitor. The range is 1 to 4094 (excluding the RSPAN VLAN). <p>Note A single session can include multiple sources (ports or VLANs), defined in a series of commands, but you cannot combine source ports and source VLANs in one session.</p> <p>(Optional) [, -] Specify a series or range of interfaces. Enter a space before and after the comma; enter a space before and after the hyphen.</p> <p>(Optional) Specify the direction of traffic to monitor. If you do not specify a traffic direction, the source interface sends both sent and received traffic.</p> <ul style="list-style-type: none"> both—Monitor both received and sent traffic. rx—Monitor received traffic. tx—Monitor sent traffic.
Step 4	monitor session <i>session_number</i> destination remote vlan <i>vlan-id</i>	Specify the RSPAN session and the destination RSPAN VLAN. For <i>session_number</i> , enter the number defined in Step 3. For <i>vlan-id</i> , specify the source RSPAN VLAN to monitor.
Step 5	end	Return to privileged EXEC mode.
Step 6	show monitor [session <i>session_number</i>] show running-config	Verify the configuration.
Step 7	copy running-config startup-config	(Optional) Save the configuration in the configuration file.

To delete a SPAN session, use the **no monitor session** *session_number* global configuration command.

To remove a source port or VLAN from the SPAN session, use the **no monitor session** *session_number* **source** {**interface** *interface-id* | **vlan** *vlan-id*} global configuration command. To remove the RSPAN VLAN from the session, use the **no monitor session** *session_number* **destination remote vlan** *vlan-id*.

This example shows how to remove any existing RSPAN configuration for session 1, configure RSPAN session 1 to monitor multiple source interfaces, and configure the destination as RSPAN VLAN 901.

```
Switch(config)# no monitor session 1
Switch(config)# monitor session 1 source interface gigabitethernet1/0/10 tx
Switch(config)# monitor session 1 source interface gigabitethernet1/0/2 rx
Switch(config)# monitor session 1 source interface gigabitethernet2/0/3
Switch(config)# monitor session 1 source interface port-channel 12
Switch(config)# monitor session 1 destination remote vlan 901
Switch(config)# end
```

Creating an RSPAN Destination Session

You configure the RSPAN destination session on a different switch or switch stack; that is, not the switch or switch stack on which the source session was configured.

Beginning in privileged EXEC mode, follow these steps to define the RSPAN VLAN on that switch, to create an RSPAN destination session, and to specify the source RSPAN VLAN and the destination port:

	Command	Purpose
Step 1	configure terminal	Enter global configuration mode.
Step 2	vlan <i>vlan-id</i>	Enter the VLAN ID of the RSPAN VLAN created from the source switch, and enter VLAN configuration mode. Note If both switches are participating in VTP and the RSPAN VLAN ID is from 2 to 1005, Steps 2 through 4 are not required because the RSPAN VLAN ID is propagated through the VTP network.
Step 3	remote-span	Identify the VLAN as the RSPAN VLAN.
Step 4	exit	Return to global configuration mode.
Step 5	no monitor session { <i>session_number</i> all local remote }	Remove any existing RSPAN configuration for the session. For <i>session_number</i> , the range is from 1 to 66. Specify all to remove all RSPAN sessions, local to remove all local sessions, or remote to remove all remote SPAN sessions.
Step 6	monitor session <i>session_number</i> source remote vlan <i>vlan-id</i>	Specify the RSPAN session and the source RSPAN VLAN. For <i>session_number</i> , the range is from 1 to 66. For <i>vlan-id</i> , specify the source RSPAN VLAN to monitor.

	Command	Purpose
Step 7	monitor session <i>session_number</i> destination interface <i>interface-id</i>	Specify the RSPAN session and the destination interface. For <i>session_number</i> , enter the number defined in Step 6. Note In an RSPAN destination session, you must use the same session number for the source RSPAN VLAN and the destination port. For <i>interface-id</i> , specify the destination interface. The destination interface must be a physical interface. Note Though visible in the command-line help string, encapsulation replicate is not supported for RSPAN. The original VLAN ID is overwritten by the RSPAN VLAN ID, and all packets appear on the destination port as untagged.
Step 8	end	Return to privileged EXEC mode.
Step 9	show monitor [session <i>session_number</i>] show running-config	Verify the configuration.
Step 10	copy running-config startup-config	(Optional) Save the configuration in the configuration file.

To delete a SPAN session, use the **no monitor session** *session_number* global configuration command. To remove a destination port from the SPAN session, use the **no monitor session** *session_number* **destination interface** *interface-id* global configuration command. To remove the RSPAN VLAN from the session, use the **no monitor session** *session_number* **source remote vlan** *vlan-id*.

This example shows how to configure VLAN 901 as the source remote VLAN and port 0/5 on switch 2 as the destination interface:

```
Switch(config)# monitor session 1 source remote vlan 901
Switch(config)# monitor session 1 destination interface gigabitethernet2/0/5
Switch(config)# end
```

Creating an RSPAN Destination Session and Configuring Ingress Traffic

Beginning in privileged EXEC mode, follow these steps to create an RSPAN destination session, to specify the source RSPAN VLAN and the destination port, and to enable ingress traffic on the destination port for a network security device (such as a Cisco IDS Sensor Appliance).



Note

Refer to the [“Creating an RSPAN Destination Session” section on page 22-20](#) for details about the keywords not related to ingress traffic. This procedure assumes the RSPAN VLAN has already been configured.

	Command	Purpose
Step 1	configure terminal	Enter global configuration mode.
Step 2	no monitor session { <i>session_number</i> all local remote }	Remove any existing SPAN configuration for the session.

	Command	Purpose
Step 3	monitor session <i>session_number</i> source remote vlan <i>vlan-id</i>	Specify the RSPAN session and the source RSPAN VLAN. For <i>session_number</i> , the range is from 1 to 66. For <i>vlan-id</i> , specify the source RSPAN VLAN to monitor.
Step 4	monitor session <i>session_number</i> destination { interface <i>interface-id</i> [, -]} [ingress { dot1q vlan <i>vlan-id</i> isl untagged vlan <i>vlan-id</i> vlan <i>vlan-id</i> }]}	Specify the SPAN session, the destination port, the packet encapsulation, and the ingress VLAN and encapsulation. For <i>session_number</i> , enter the number defined in Step 4. Note In an RSPAN destination session, you must use the same session number for the source RSPAN VLAN and the destination port. For <i>interface-id</i> , specify the destination interface. The destination interface must be a physical interface. Note Though visible in the command-line help string, encapsulation replicate is not supported for RSPAN. The original VLAN ID is overwritten by the RSPAN VLAN ID, and all packets appear on the destination port as untagged. (Optional) [, -] Specify a series or range of interfaces. Enter a space before and after the comma; enter a space before and after the hyphen. Enter ingress with additional keywords to enable ingress traffic forwarding on the destination port and to specify the encapsulation type: <ul style="list-style-type: none"> • dot1q vlan <i>vlan-id</i>—Forward ingress packets with 802.1Q encapsulation with the specified VLAN as the default VLAN. • isl—Forward ingress packets with ISL encapsulation. • untagged vlan <i>vlan-id</i> or vlan <i>vlan-id</i>—Forward ingress packets with untagged encapsulation type with the specified VLAN as the default VLAN.
Step 5	end	Return to privileged EXEC mode.
Step 6	show monitor [session <i>session_number</i>] show running-config	Verify the configuration.
Step 7	copy running-config startup-config	(Optional) Save the configuration in the configuration file.

To delete an RSPAN session, use the **no monitor session** *session_number* global configuration command. To remove a destination port from the RSPAN session, use the **no monitor session** *session_number* **destination interface** *interface-id* global configuration command. The ingress options are ignored with the **no** form of the command.

This example shows how to configure VLAN 901 as the source remote VLAN in RSPAN session 2, to configure Gigabit Ethernet source port 0/2 on switch 1 as the destination interface, and to enable ingress forwarding on the interface with VLAN 6 as the default ingress VLAN.

```
Switch(config)# monitor session 2 source remote vlan 901
Switch(config)# monitor session 2 destination interface gigabitethernet1/0/2 ingress
vlan 6
Switch(config)# end
```

Specifying VLANs to Filter

Beginning in privileged EXEC mode, follow these steps to configure the RSPAN source session to limit RSPAN source traffic to specific VLANs:

	Command	Purpose
Step 1	configure terminal	Enter global configuration mode.
Step 2	no monitor session { <i>session_number</i> all local remote }	Remove any existing SPAN configuration for the session. For <i>session_number</i> , the range is from 1 to 66. Specify all to remove all SPAN sessions, local to remove all local sessions, or remote to remove all remote SPAN sessions.
Step 3	monitor session <i>session_number</i> source interface <i>interface-id</i>	Specify the characteristics of the source port (monitored port) and SPAN session. For <i>session_number</i> , the range is from 1 to 66. For <i>interface-id</i> , specify the source port to monitor. The interface specified must already be configured as a trunk port.
Step 4	monitor session <i>session_number</i> filter vlan <i>vlan-id</i> [, -]	Limit the SPAN source traffic to specific VLANs. For <i>session_number</i> , enter the session number specified in step 3. For <i>vlan-id</i> , the range is 1 to 4094. (Optional) Use a comma (,) to specify a series of VLANs or use a hyphen (-) to specify a range of VLANs. Enter a space before and after the comma; enter a space before and after the hyphen.
Step 5	monitor session <i>session_number</i> destination remote vlan <i>vlan-id</i>	Specify the RSPAN session and the destination remote VLAN (RSPAN VLAN). For <i>session_number</i> , enter the session number specified in step 3. For <i>vlan-id</i> , specify the RSPAN VLAN to carry the monitored traffic to the destination port.
Step 6	end	Return to privileged EXEC mode.
Step 7	show monitor [session <i>session_number</i>] show running-config	Verify the configuration.
Step 8	copy running-config startup-config	(Optional) Save the configuration in the configuration file.

To monitor all VLANs on the trunk port, use the **no monitor session** *session_number* **filter vlan** global configuration command.

This example shows how to remove any existing configuration on RSPAN session 2, configure RSPAN session 2 to monitor traffic received on trunk port 0/4 on switch 1, and send traffic for only VLANs 1 through 5 and 9 to destination RSPAN VLAN 902.

```
Switch(config)# no monitor session 2
Switch(config)# monitor session 2 source interface gigabitethernet1/0/4 rx
Switch(config)# monitor session 2 filter vlan 1 - 5 , 9
Switch(config)# monitor session 2 destination remote vlan 902
Switch(config)# end
```

Displaying SPAN and RSPAN Status

To display the current SPAN or RSPAN configuration, use the **show monitor** user EXEC command. You can also use the **show running-config** privileged EXEC command to display configured SPAN or RSPAN sessions.

This is an example of output for a switch with two source sessions configured:

```
Switch# show monitor
Session 1
-----
Type           :Local Session
Source Ports:
  RX Only:      Fa4/0/24
  TX Only:      None
  Both:         Fa2/0/1-2,Fa4/0/1-5
Source VLANs:
  RX Only:      None
  TX Only:      None
  Both:         None
Source RSPAN VLAN:None
Destination Ports:Fa2/0/18
  Encapsulation:Replicate
Filter VLANs:   None
Dest RSPAN VLAN: None

Session 2
-----
Type           :Remote Source Session
Source Ports:
  RX Only:      None
  TX Only:      None
  Both:         None
Source VLANs:
  RX Only:      None
  TX Only:      10
  Both:         1-9
Source RSPAN VLAN:None
Destination Ports:None
Filter VLANs:   None
Dest RSPAN VLAN: 105
```

This is an example of output for the **show monitor session all** user EXEC command when ingress traffic forwarding is enabled:

```
Switch# show monitor session all
Session 1
-----
Type                :Local Session
Source Ports       :
    Both            :Fa1/0/2
Destination Ports  :Fa2/0/2
Encapsulation      :Replicate
    Ingress:Enabled, default VLAN = 5
Ingress encapsulation:DOT1Q

Session 2
-----
Type                :Local Session
Source Ports       :
    Both            :Fa3/0/2
Destination Ports  :Fa3/0/4
Encapsulation      :Replicate
    Ingress:Enabled
Ingress encapsulation:ISL
```

This is an example of the configuration and output for the **show running-config** privileged EXEC command when ingress traffic forwarding is enabled. SPAN and RSPAN sessions are displayed near the end of the output.

```
Switch(config)# monitor session 2 source remote vlan 901
Switch(config)# monitor session 2 destination interface gigabitethernet1/0/2 ingress
vlan 6
Switch(config)# end
Switch# show running-config
Building configuration...

Current configuration : 8238 bytes
!
version 12.1
no service pad
service timestamps debug uptime
service timestamps log datetime
no service password-encryption
service sequence-numbers

<output truncated>

!
!
monitor session 2 destination interface gil/0/2 ingress vlan 6
end
```

