



Switch Installation

This chapter contains these topics:

- [Safety Warnings, on page 1](#)
- [Box Contents, on page 5](#)
- [Tools and Equipment, on page 7](#)
- [Installation Guidelines, on page 8](#)
- [Verifying Switch Operation, on page 8](#)
- [Installing the Switch, on page 9](#)
- [Installing the Power Cord Retainer \(Optional\), on page 20](#)
- [Installing SFP Modules, on page 22](#)
- [Connecting to SFP or SFP+ Modules, on page 24](#)
- [10/100/1000 PoE+ Port Connections, on page 26](#)
- [10/100/1000 Ethernet Port Connections, on page 27](#)

Safety Warnings



Warning To reduce the risk of electric shock, disconnect all power cords before servicing.



Warning The switch is to be connected only to PoE networks without routing to the outside plant.

This section includes the warning statements relating to basic installation. Read this section before you start the installation procedure.



Warning Before working on equipment that is connected to power lines, remove jewelry (including rings, necklaces, and watches). Metal objects will heat up when connected to power and ground and can cause serious burns or weld the metal object to the terminals. **Statement 43**



Warning Do not stack the chassis on any other equipment. If the chassis falls, it can cause severe bodily injury and equipment damage. **Statement 48**



Warning Read the wall-mounting instructions carefully before beginning installation. Failure to use the correct hardware or to follow the correct procedures could result in a hazardous situation to people and damage to the system. **Statement 378**



Warning Connect USB Device to a Certified USB Port. **Statement 388**



Warning To avoid or reduce the risk of personal injury, do not use the product if the product has been exposed to irregular environmental conditions, if the product has been misused or if parts of the product have been damaged. Consult qualified service personnel. Never try to service the product yourself. **Statement 0416**



Warning To reduce the risk of electric shock, fire or personal injury, do not place power cables in areas where they may be walked on or damaged by items placed upon or against it. **Statement 0417**



Warning This product is intended for use in a normal environment based on the standard IEC60950-1 and IEC62368-1. Do not use the product in vehicles, on board ships, in aircrafts or in medical applications with physical connection to the patient, nor in environments with exposure to moisture, dust, vibration or ingress of water. **Statement 0418**



Warning Equipment is intended for installation in Information Technology Equipment Rooms. Suitable for installation in Information Technology Rooms in accordance with Article 645 of the National ElectricalCode and NFPA 75. **Statement 0444**



Warning Do not work on the system or connect or disconnect cables during periods of lightning activity. **Statement 1001**



Warning Read the installation instructions before connecting the system to the power source. **Statement 1004**

**Warning**

To prevent bodily injury when mounting or servicing this unit in a rack, you must take special precautions to ensure that the system remains stable. The following guidelines are provided to ensure your safety:

- This unit should be mounted at the bottom of the rack if it is the only unit in the rack.
- When mounting this unit in a partially filled rack, load the rack from the bottom to the top with the heaviest component at the bottom of the rack.
- If the rack is provided with stabilizing devices, install the stabilizers before mounting or servicing the unit in the rack.

Statement 1006**Warning**

Class 1 laser product. **Statement 1008**

**Warning**

There is the danger of explosion if the battery is replaced incorrectly. Replace the battery only with the same or equivalent type recommended by the manufacturer. Dispose of used batteries according to the manufacturer's instructions. **Statement 1015**

**Warning**

This unit is intended for installation in restricted access areas. A restricted access area can be accessed only through the use of a special tool, lock and key, or other means of security. **Statement 1017**

**Warning**

Take care when connecting units to the supply circuit so that wiring is not overloaded. **Statement 1018**

**Warning**

The plug-socket combination must be accessible at all times, because it serves as the main disconnecting device. **Statement 1019**

**Warning**

This equipment must be grounded. Never defeat the ground conductor or operate the equipment in the absence of a suitably installed ground conductor. Contact the appropriate electrical inspection authority or an electrician if you are uncertain that suitable grounding is available. **Statement 1024**

**Warning**

Class 1 LED product. **Statement 1027**



Warning Only trained and qualified personnel should be allowed to install, replace, or service this equipment. **Statement 1030**



Warning Ultimate disposal of this product should be handled according to all national laws and regulations. **Statement 1040**



Warning When installing or replacing the unit, the ground connection must always be made first and disconnected last. **Statement 1046**



Warning To prevent the system from overheating, do not operate it in an area that exceeds the maximum recommended ambient temperature of: <122°F (50°C). **Statement 1047**



Warning Invisible laser radiation may be emitted from disconnected fibers or connectors. Do not stare into beams or view directly with optical instruments. **Statement 1051**



Warning Invisible laser radiation may be emitted from the end of the unterminated fiber cable or connector. Do not view directly with optical instruments. Viewing the laser output with certain optical instruments (for example, eye loupes, magnifiers, and microscopes) within a distance of 100 mm may pose an eye hazard.

Fiber type and Core diameter (µm)	Wavelength (nm)	Max. Power (mW)
SM 11	1200 - 1400	39 - 50
MM 62.5	1200 - 1400	150
MM 50	1200 - 1400	135
SM 11	1400 - 1600	112 - 145

Statement 1056



Warning This warning symbol means danger. You are in a situation that could cause bodily injury. Before you work on any equipment, be aware of the hazards involved with electrical circuitry and be familiar with standard practices for preventing accidents. Use the statement number provided at the end of each warning to locate its translation in the translated safety warnings that accompanied this device. **Statement 1071**



Warning Voltages that present a shock hazard may exist on Power over Ethernet (PoE) circuits if interconnections are made using uninsulated exposed metal contacts, conductors, or terminals. Avoid using such interconnection methods, unless the exposed metal parts are located within a restricted access location and users and service people who are authorized within the restricted access location are made aware of the hazard. A restricted access area can be accessed only through the use of a special tool, lock and key or other means of security. **Statement 1072**



Warning No user-serviceable parts inside. Do not open. **Statement 1073**



Warning Installation of the equipment must comply with local and national electrical codes. **Statement 1074**



Warning To prevent airflow restriction, allow clearance around the ventilation openings to be at least: 3 inches (7.6 cm). **Statement 1076**



Warning Hot surface. **Statement 1079**

Box Contents

This section lists the contents of the shipping box for a 24-port and 48-port Cisco Catalyst 1000 switch.

Figure 1: Box Contents of a 24-Port and 48-Port Cisco Catalyst 1000 Switch

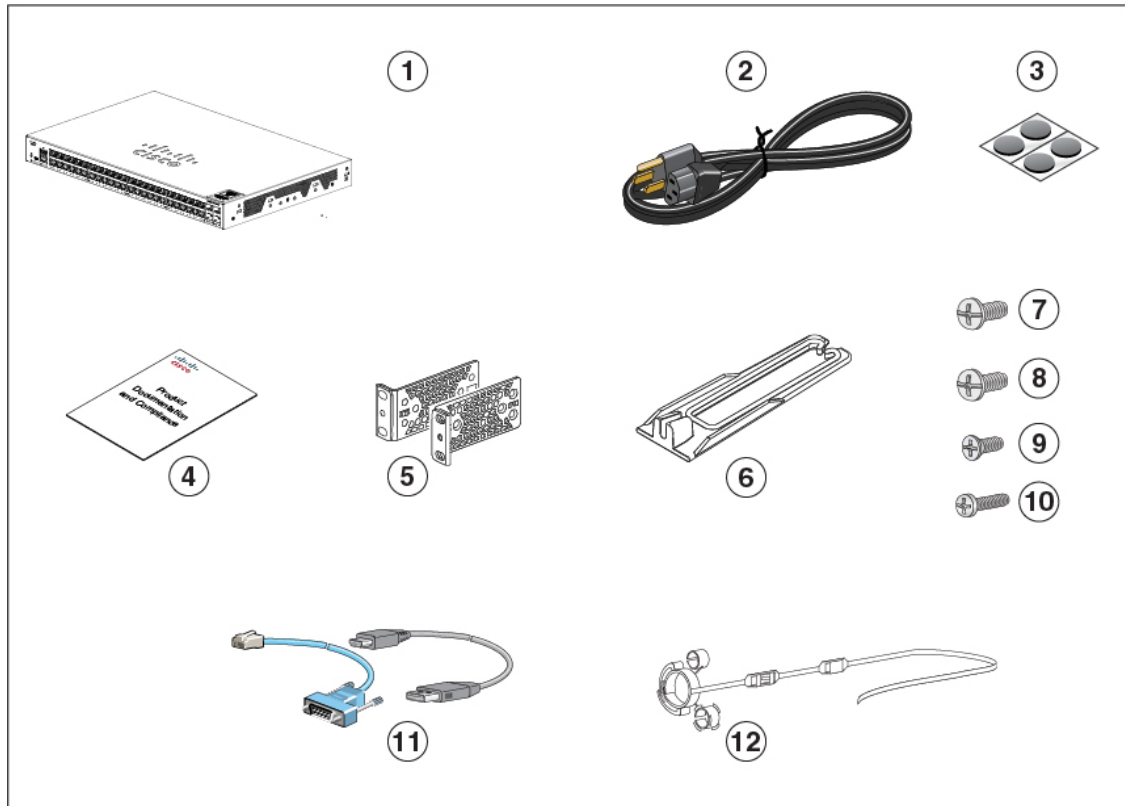

356404

1	24-port or 48-port Cisco Catalyst 1000 switch	7	Four Number-12 Phillips pan-head screws (48-0523-01)
2	AC power cord	8	Four Number-10 Phillips pan-head screws (48-0627-01)
3	Four rubber-mounting feet (51-0089)	9	Eight Number-8 Phillips flat-head screws (48-2927-01)
4	Compliance documentation (78-101287-01)	10	One black Phillips machine screw (48-0654-01)
5	Two 19-inch mounting brackets	11	(Optional) Console cable or USB cable
6	Cable guide	12	(Optional) Power cord retainer

This section lists the contents of the shipping box for a 24-port and 48-port Cisco Catalyst 1000 Fast Ethernet switch.

Figure 2: Box Contents of a 24-Port and 48-Port Cisco Catalyst 1000 Fast Ethernet Switch

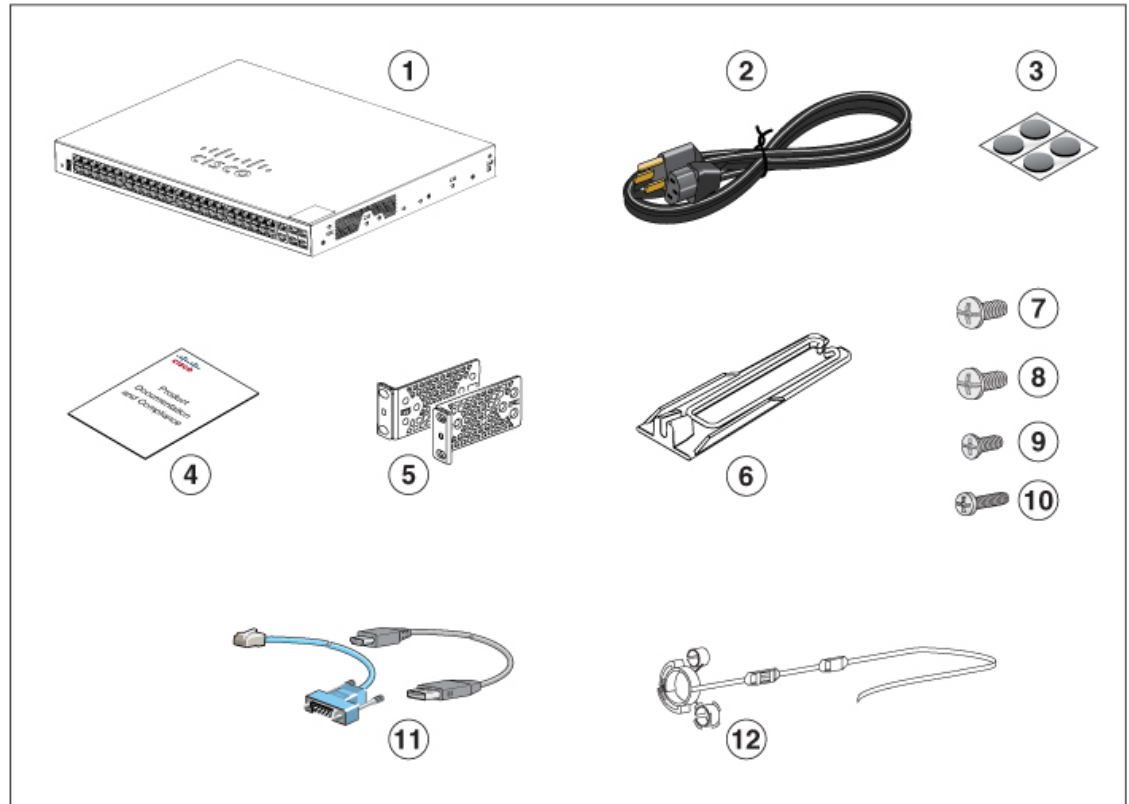

1	24-port or 48-port Cisco Catalyst 1000 Fast Ethernet switch	7	Four Number-12 Phillips pan-head screws (48-0523-01)
2	AC power cord	8	Four Number-10 Phillips pan-head screws (48-0627-01)
3	Four rubber-mounting feet (51-0089)	9	Eight Number-8 Phillips flat-head screws (48-2927-01)
4	Compliance documentation (78-101287-01)	10	One black Phillips machine screw (48-0654-01)
5	Two 19-inch mounting brackets	11	(Optional) Console cable or USB cable
6	Cable guide	12	(Optional) Power cord retainer

Tools and Equipment

Obtain these necessary tools:

- A Number-2 Phillips screwdriver.

Installation Guidelines

When determining where to install the switch, verify that these guidelines are met:

- Clearance to the switch's front and rear panel should meet these conditions:
 - Front-panel LEDs can be easily read.
 - Access to ports is sufficient for unrestricted cabling.
 - AC power cord can reach from the AC power outlet to the connector on the switch's rear panel.
- Cabling is away from sources of electrical noise, such as radios, power lines, and fluorescent lighting fixtures. Make sure that the cabling is safely away from other devices that might damage the cables.
- Airflow around the switch and through the vents is unrestricted. To avoid any flow blockage, we strongly recommend these guidelines:
 - Allow at least 3 in. (7.6 cm) of clearance from the left and the right sides, and the front and rear of the switch.
 - Allow at least 1.75 in. (4 cm) of clearance from the top cover, if you are installing the switch in upright position.
 - Allow at least 3 in. (7.6 cm) of clearance from the top cover, if you are installing the switch.
- Temperature around the unit does not exceed 122°F (50°C). If the switch is installed in a closed or multirack assembly, the temperature around it might be greater than normal room temperature.
- Humidity around the switch does not exceed 95 percent.
- Altitude at the installation site is not greater than 10,000 feet.
- For 10/100/1000 fixed ports, the cable length from a switch to a connected device cannot exceed 328 feet (100 meters).
- Cooling mechanisms, such as fans and blowers in the switch, can draw dust and other particles causing contaminant build-up inside the chassis, which can result in system malfunction. You must install this equipment in an environment as free from dust and foreign conductive material (such as metal flakes from construction activities) as is possible.
- None of the switch models can be deployed outside of the wiring closet. These switches can only be deployed indoors.

Verifying Switch Operation

Before you install the switch in a rack, on a wall, or on a table or shelf, power on the switch and verify that it passes POST.

To power on the switch, plug one end of the AC power cord into the switch AC power connector, and plug the other end into an AC power outlet.

As the switch powers on, it begins the POST, a series of tests that runs automatically to ensure that the switch functions properly. LEDs can blink during the test. The SYST LED blinks green.

When the switch completes POST successfully, the SYST LED remains green. If a switch fails POST, the SYST LED turns amber.

POST failures are usually fatal. Call Cisco technical support representative if your switch fails POST.

After a successful POST, unplug the power cord from the switch and install the switch in a rack, on a wall, on a table, or on a shelf.

Installing the Switch

Rack-Mounting

Installation in other than 19-inch racks requires a bracket kit not included with the switch.



Warning

To prevent bodily injury when mounting or servicing this unit in a rack, you must take special precautions to ensure that the system remains stable. The following guidelines are provided to ensure your safety:

- This unit should be mounted at the bottom of the rack if it is the only unit in the rack.
- When mounting this unit in a partially filled rack, load the rack from the bottom to the top with the heaviest component at the bottom of the rack.
- If the rack is provided with stabilizing devices, install the stabilizers before mounting or servicing the unit in the rack.

Statement 1006

Figure 3: Rack-Mounting Brackets

This figure shows the standard 19-inch brackets and other optional mounting brackets. You can order the optional brackets from your Cisco sales

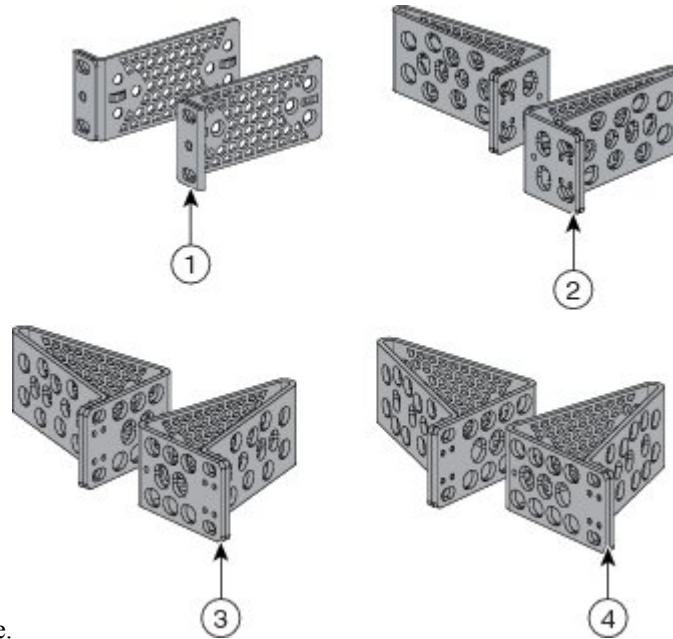

representative.

1	19-inch brackets	3	23-inch brackets
2	ETSI brackets	4	24-inch brackets

3416760

Attaching the Rack-Mount Brackets

Attaching the Rack-Mount Brackets to a Cisco Catalyst 1000 24-Port and 48-Port Switch

Use two Phillips flat-head screws to attach the long side of the bracket to each side of the switch.

Figure 4: Attaching 19-inch Brackets to a Cisco Catalyst 1000 24-Port and 48-Port Switch

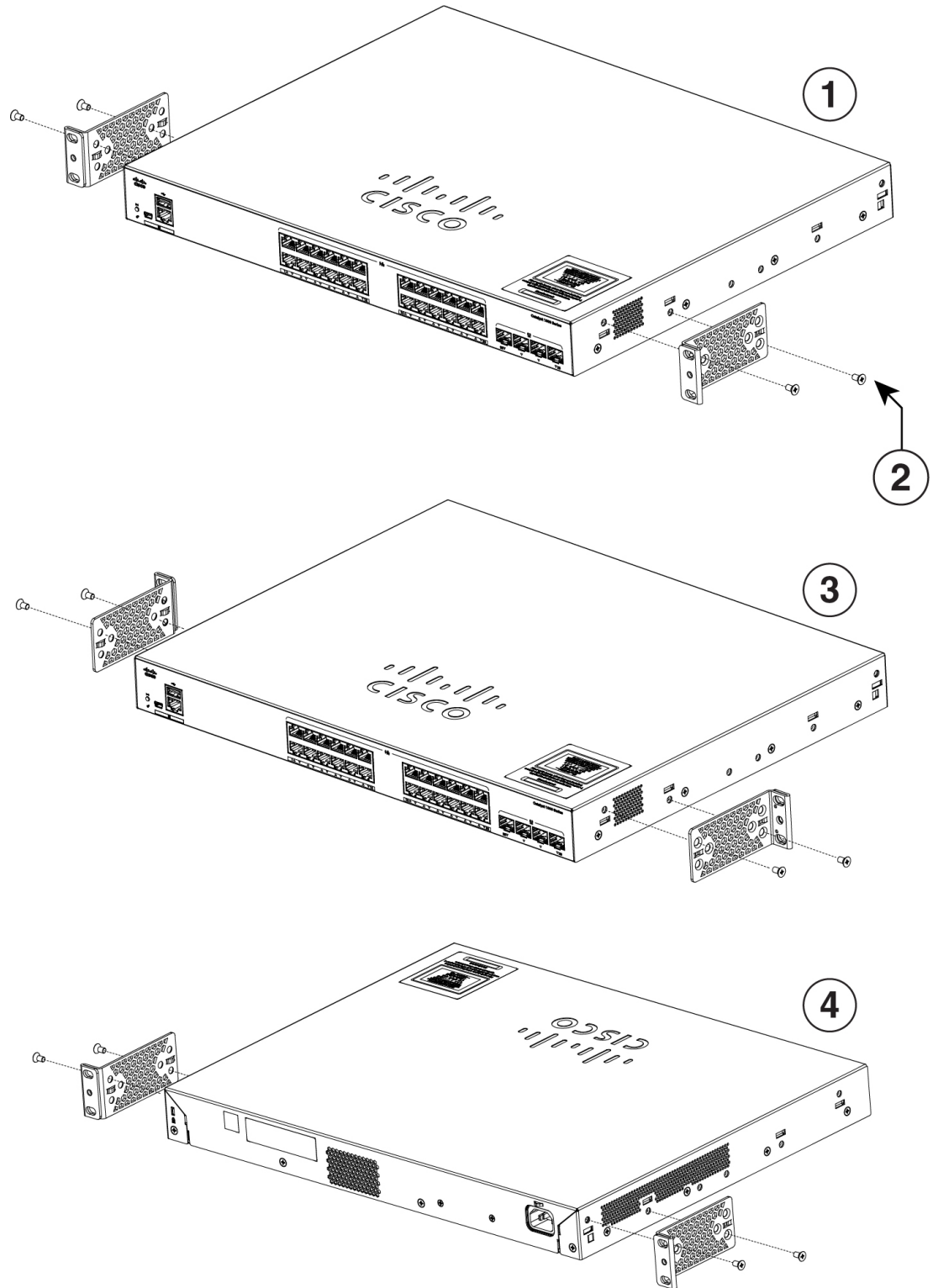

1	Front-mounting position	3	Mid-mounting position
---	-------------------------	---	-----------------------

356405

Attaching the Rack-Mount Brackets

2	Number-8 Phillips flat-head screws	4	Rear-mounting position
---	------------------------------------	---	------------------------

Figure 5: Attaching 19-inch Brackets to a Cisco Catalyst 1000 24-Port and 48-Port Fast Ethernet Switch

1	Front-mounting position	3	Mid-mounting position
2	Number-8 Phillips flat-head screws	4	Rear-mounting position

Mounting a 24-Port or 48-Port Switch in a Rack

Procedure

- Step 1** Use the four supplied Phillips machine screws to attach the brackets to the rack.
- Step 2** Use the black Phillips machine screw to attach the cable guide to the left or right bracket.

Figure 6: Mounting a Cisco Catalyst 1000 24-Port and 48-Port Switch in a Rack

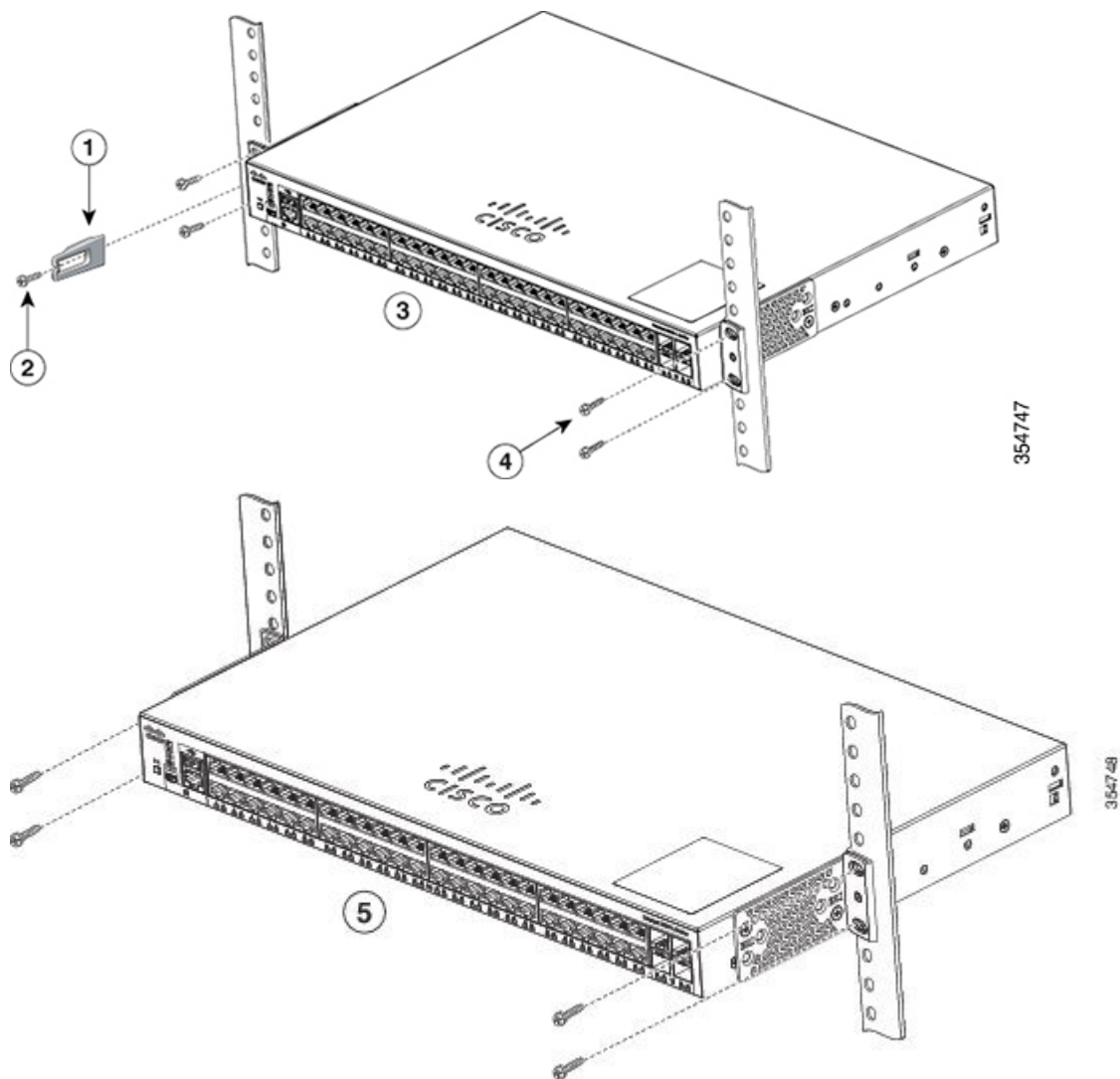

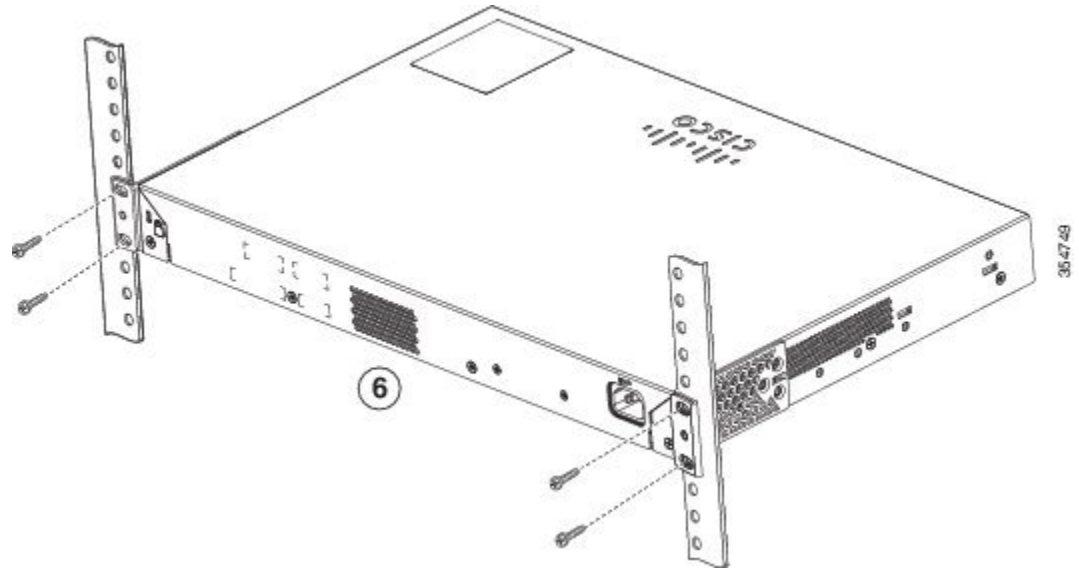

1	Cable guide	4	Number-12 Phillips pan-head screws (48-0523-01) or Number-10 Phillips pan-head screws (48-0627-01)
2	Phillips machine screw, black (48-0654-01)	5	Mid-mounting position
3	Front-mounting position	6	Rear-mounting position

Figure 7: Mounting a Cisco Catalyst 1000 24-Port and 48-Port Fast Ethernet Switch in a Rack

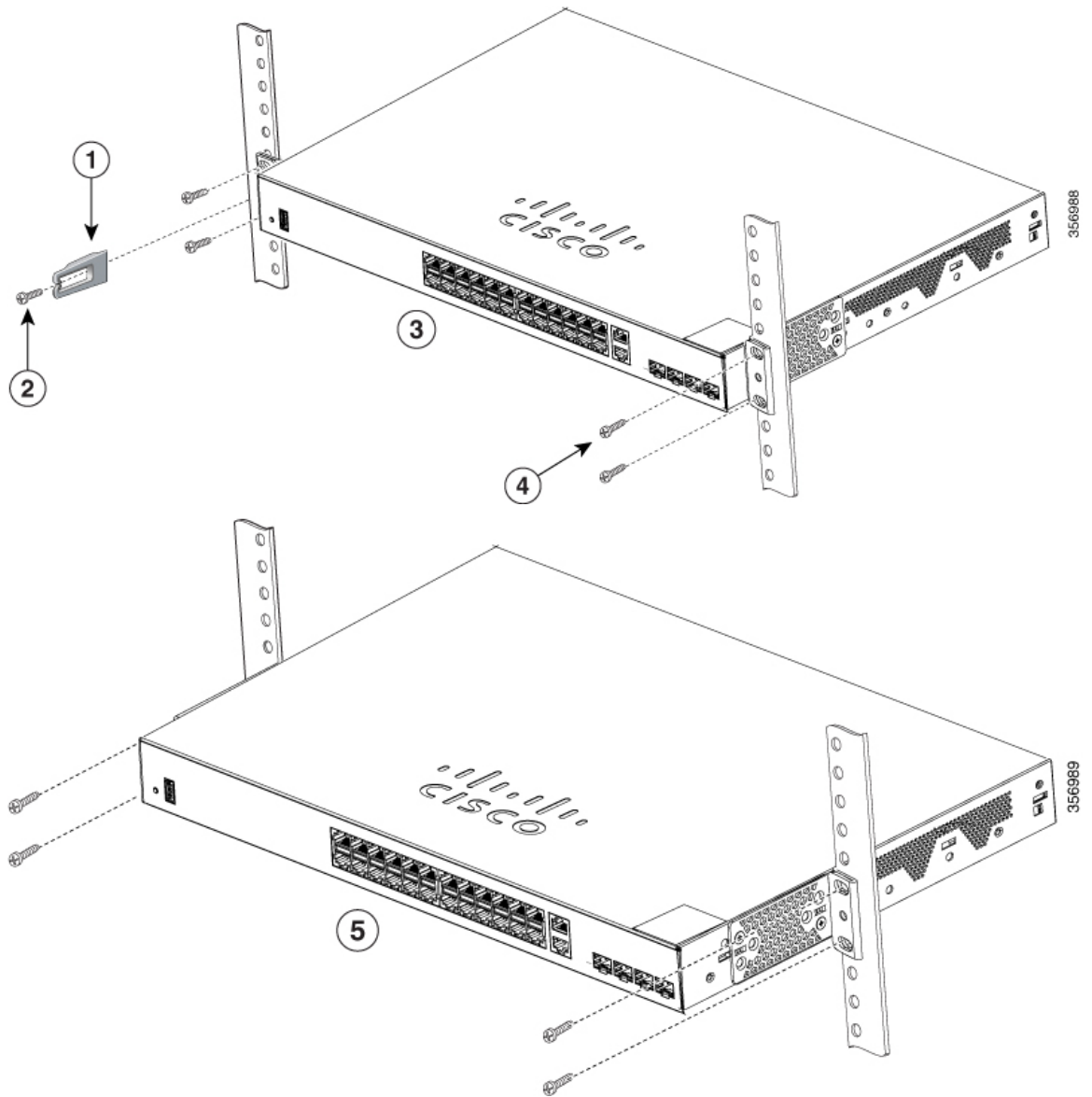

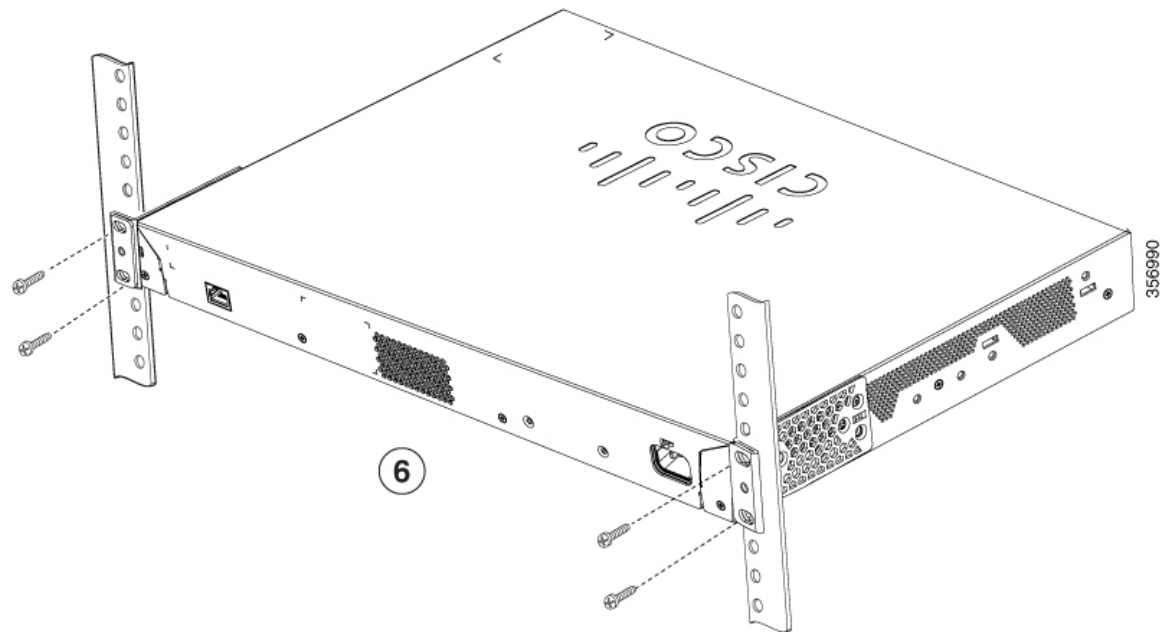

1	Cable guide	4	Number-12 Phillips pan-head screws (48-0523-01) or Number-10 Phillips pan-head screws (48-0627-01)
2	Phillips machine screw, black (48-0654-01)	5	Mid-mounting position
3	Front-mounting position	6	Rear-mounting position

Wall-Mounting



Warning Read the wall-mounting instructions carefully before beginning installation. Failure to use the correct hardware or to follow the correct procedures could result in a hazardous situation to people and damage to the system.
Statement 378

Attaching the Brackets for Wall-Mounting

Procedure

- Step 1** Attach a 19-inch bracket to one side of the switch.
- Step 2** Follow the same steps to attach the second bracket to the opposite side.

Figure 8: Attaching the 19-inch Brackets for Wall-Mounting

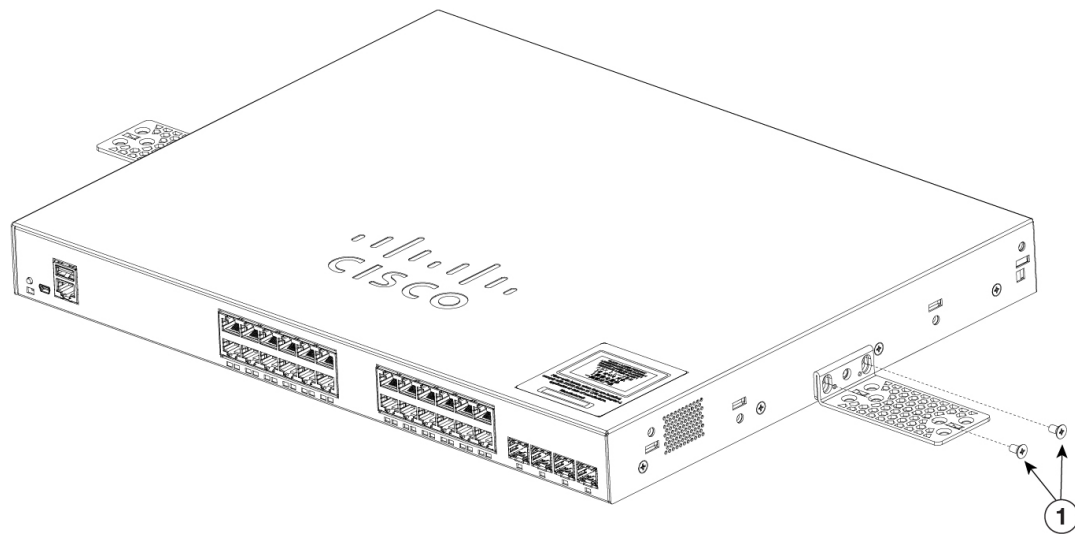

3566406

- | | |
|---|--|
| 1 | Number-8 phillips flat-head screws
(48-2927-01) |
|---|--|

Mounting on a Wall

For the best support of the switch and cables, make sure that the switch is attached securely to wall studs or to a firmly attached plywood-mounting backboard. Mount the switch with the front panel facing down.



Warning Read the wall-mounting instructions carefully before beginning installation. Failure to use the correct hardware or to follow the correct procedures could result in a hazardous situation to people and damage to the system.
Statement 378



Caution Following safety regulations, wall-mount the switch with its front panel facing down.

Figure 9: Mounting on a Wall

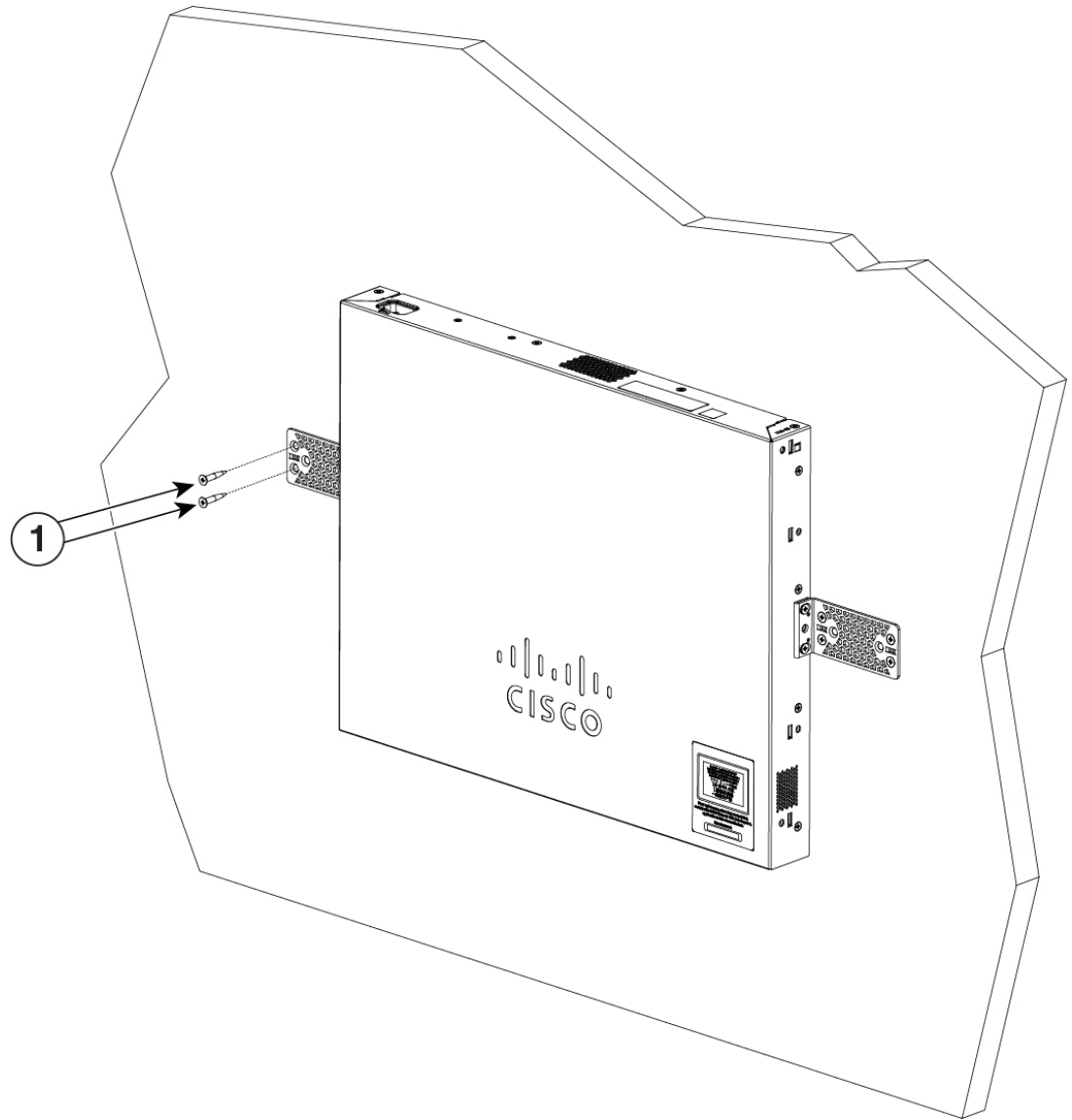

356407

1	User-supplied screws (for example, you can use # 6 wood screws with a washer head 1-inch long).
---	---

When you complete the switch installation, see *After Switch Installation* for information on switch configuration.

Installing the Switch on a Table or Shelf

Procedure

- Step 1** To install the switch on a table or shelf, locate the adhesive strip with the rubber feet in the mounting-kit envelope.

- Step 2** Attach the four rubber feet to the four circular etches on the bottom of the chassis.
- Step 3** Place the switch on the table or shelf near an AC power source.
- Step 4** When you complete the switch installation, see *After Switch Installation* for information on switch configuration.

After Switch Installation

- Configure the switch using the Configuration Setup wizard to enter the initial switch configuration.
- Install the power cord retainer (optional).
- Connect to the front-panel ports.

Installing the Power Cord Retainer (Optional)

The power cord retainer is optional (part number [PWR-CLP=]). You can order it when you order your switch.

Procedure

- Step 1** Choose the sleeve size of the power cord retainer based on the thickness of the cord. The smaller sleeve can be snapped off and used for thin cords.
- Step 2** Slide the retainer around the AC power cord, and pass it around the loop on the switch.

Figure 10: Inserting the Retainer Through the Lanced Loop

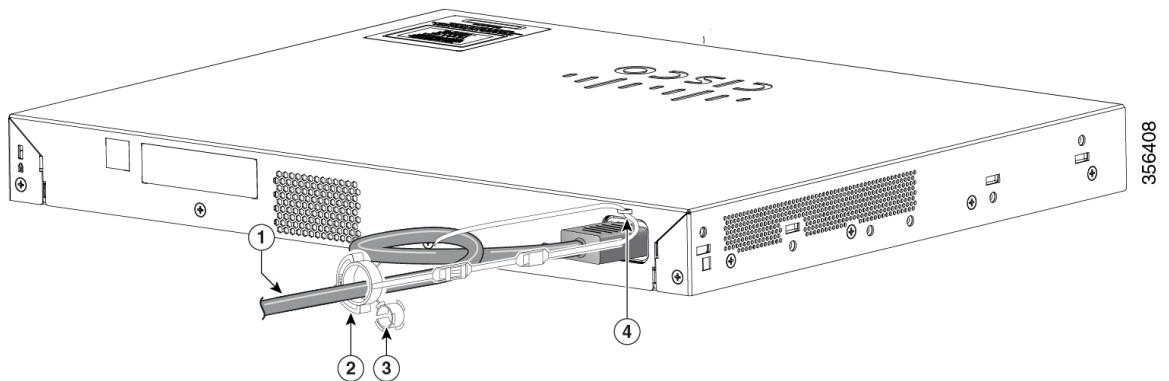

1	AC power cord	3	Sleeve for thin
2	Power cord retainer	4	Loop

- Step 3** Slide the retainer through the first latch.

Figure 11: Sliding the Retainer Through the Latch

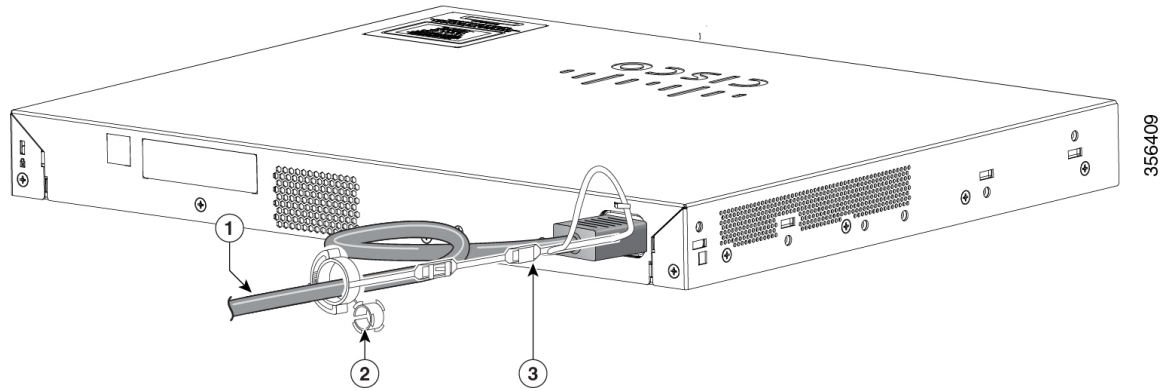

1	AC power cord	3	Latch
2	Smaller sleeve for thin power cords		

Step 4 Slide the retainer through the other latches to lock it.

Figure 12: Locking the Retainer

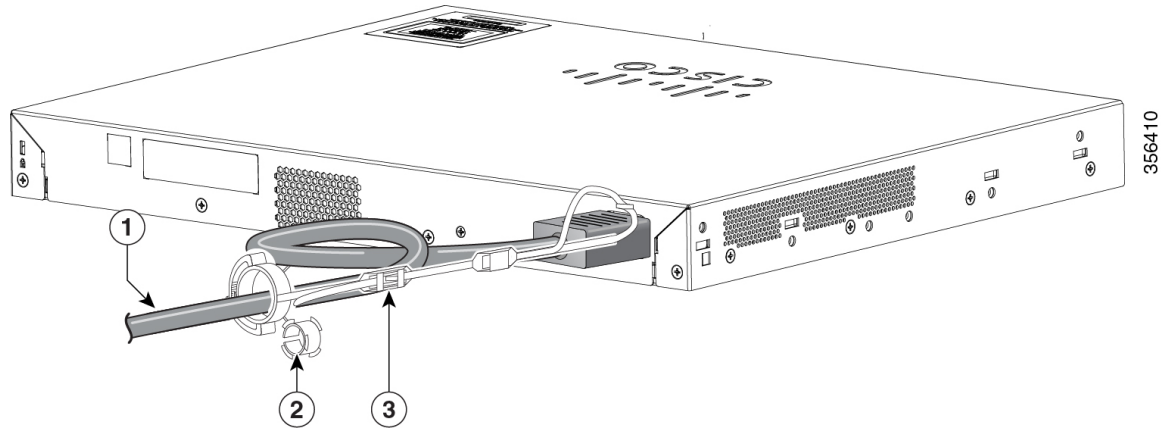

1	AC power cord	3	Latches
2	Sleeve for thin power cords		

Step 5 (Optional) Use the small sleeve for thin power cords. Use the small sleeve to provide greater stability for thin cords. Detach the sleeve, and slide it over the power cord.

Figure 13: Sleeve Around the Power Cord

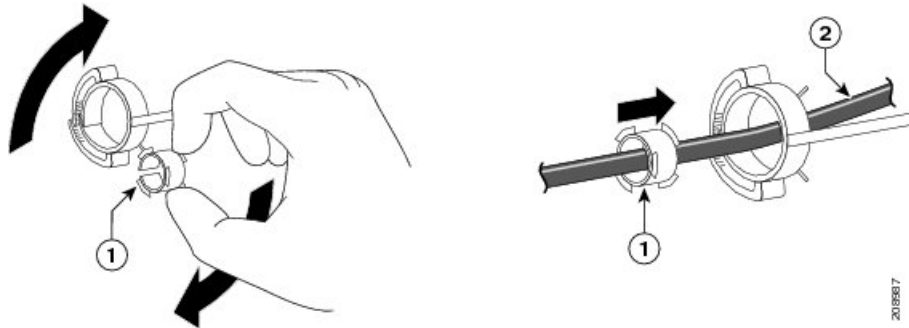

1	Sleeve for thin power cords	2	AC power cord
---	-----------------------------	---	---------------

Step 6 Secure the AC power cord by pressing on the retainer.

Figure 14: Securing the Power Cord in the Retainer

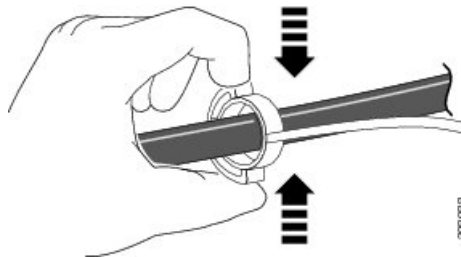

Installing SFP Modules

See the switch release notes on Cisco.com for the list of supported SFP modules. Use only Cisco SFP modules on the switch. Each Cisco module has an internal serial EEPROM that is encoded with security information. This encoding provides a way for Cisco to identify and validate that the module meets the requirements for the switch.

For information about installing, removing, cabling, and troubleshooting SFP modules, see the module documentation that shipped with your device.

Installing an SFP or SFP+ Module

Before you begin

When installing SFP or SFP+ modules, observe these guidelines:

- Do not remove the dust plugs from the modules or the rubber caps from the fiber-optic cable until you are ready to connect the cable. The plugs and caps protect the module ports and cables from contamination and ambient light.

- To prevent ESD damage, follow your normal board and component handling procedures when connecting cables to the switch and other devices.



Caution Removing and installing an SFP or SFP+ module can shorten its useful life. Do not remove and insert any module more often than is absolutely necessary.

Procedure

- Step 1** Attach an ESD-preventive wrist strap to your wrist and to a bare metal surface.
- Step 2** Find the send (TX) and receive (RX) markings on the module top.
On some SFP or SFP+ modules, the send and receive (TX and RX) markings might be replaced by arrows that show the direction of the connection.
- Step 3** If the module has a bale-clasp latch, move it to the open, unlocked position.
- Step 4** Align the module in front of the slot opening, and push until you feel the connector snap into place.
- Step 5** If the module has a bale-clasp latch, close it.
- Step 6** For fiber-optic SFP or SFP+ modules, remove the dust plugs and save.
- Step 7** Connect the SFP cables.

Figure 15: Installing an SFP Module

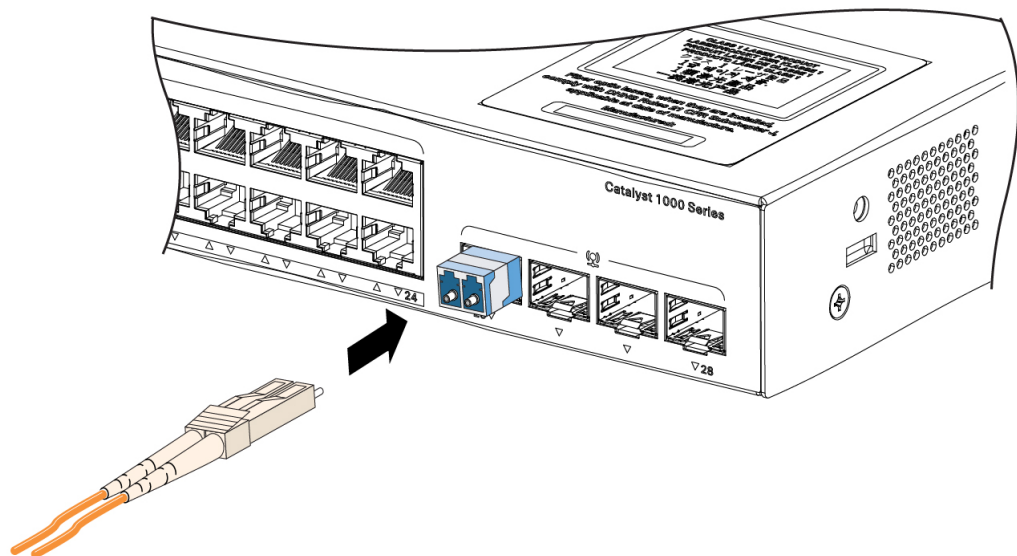

356411

Removing an SFP or SFP+ Module

Procedure

- Step 1** Attach an ESD-preventive wrist strap to your wrist and to a bare metal surface.
 - Step 2** Disconnect the cable from the SFP or SFP+ module. For reattachment, note which cable connector plug is send (TX) and which is receive (RX).
 - Step 3** Insert a dust plug into the optical ports of the SFP or SFP+ module to keep the optical interfaces clean.
 - Step 4** If the module has a bale-clasp latch, pull the bale out and down to eject the module. If the latch is obstructed and you cannot use your finger, use a small, flat-blade screwdriver or other long, narrow instrument to open the latch.
 - Step 5** Grasp the SFP or SFP+ module, and carefully remove it from the module slot.
 - Step 6** Place the module in an antistatic bag or other protective environment.
-

Connecting to SFP or SFP+ Modules

Connecting to Fiber-Optic SFP or SFP+ Modules



Warning Class 1 laser product. Statement 1008



Caution Do not remove the rubber plugs from the SFP or SFP+ module port or the rubber caps from the fiber-optic cable until you are ready to connect the cable. The plugs and caps protect the SFP module ports and cables from contamination and ambient light. Before connecting to the SFP module, be sure that you understand the port and cabling stipulations.

Procedure

- Step 1** Remove the rubber plugs from the module port and fiber-optic cable, and store them for future use.
- Step 2** Insert one end of the fiber-optic cable into the SFP or SFP+ module port.
- Step 3** Insert the other cable end into a fiber-optic receptacle on a target device.

Figure 16: Connecting to a Fiber-Optic SFP Module Port

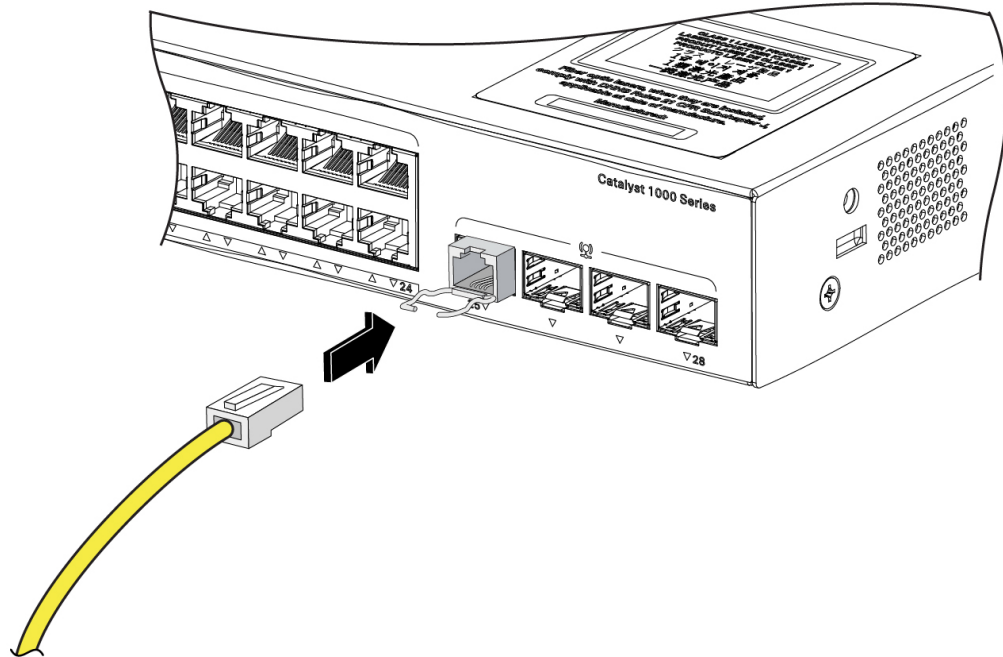

356412

Step 4 Observe the port status LED.

The LED turns green when the switch and the target device have an established link.

If the LED is off, the target device might not be turned on, there might be a cable problem, or there might be problem with the adapter installed in the target device.

Connecting to 1000BASE-T SFP

When connecting to a 1000BASE-T device, be sure to use a four twisted-pair, Category 5 or higher cable.



Note The automatic medium-dependent interface crossover (auto-MDIX) feature is enabled by default. For configuration information for this feature, see the switch software configuration guide or the switch command reference on Cisco.com.



Caution To prevent ESD damage, follow your normal board and component handling procedures.

Procedure

- Step 1** Connect one end of the cable to the SFP module port. Insert a four twisted-pair, straight-through cable when you connect to servers, workstations, and routers. Insert a four twisted-pair, crossover cable when you connect to switches or repeaters.
- Step 2** Connect the other end of the cable to an RJ-45 connector on the other device.

Figure 17: Connecting to a 1000BASE-T SFP Module

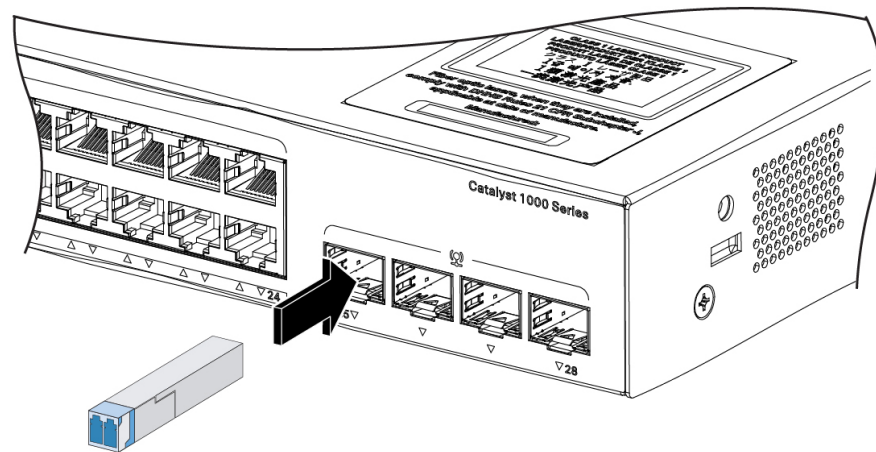

3556413

1	RJ-45 connector
---	-----------------

- Step 3** Observe the port status LED.
- The LED turns green when the switch and the other device have an established link.
 - The LED turns amber while the STP discovers the network topology and searches for loops. This process takes about 30 seconds, and then the port LED turns green.
 - If the LED is off, the other device might not be turned on, there might be a cable problem, or there might be a problem with the adapter in the other device.
- Step 4** If necessary, reconfigure and restart the switch or other device.

10/100/1000 PoE+ Port Connections

A powered device connected to a PoE port does not receive power:

- Use the **show hardware led port power** privileged EXEC command to show the PoE status for all ports.
- Use the **show interfaces** privileged EXEC command to see if the port is in error-disabled, disabled, or shutdown. Reenable the port if necessary.

- Verify that the power supply installed in the switch meets the power requirements of your connected devices.
- Verify that there is sufficient PoE power budget to provide power to the attached device. Use the **show power inline** global configuration command to check on the available PoE power budget.
- Verify the cable type. Many legacy powered devices, including older Cisco IP phones and access points that do not fully support IEEE 802.3af, might not support PoE when connected to the switch by a crossover cable. Replace the crossover cable with a straight-through cable.



Caution Noncompliant cabling or powered devices can cause a PoE port fault. Use only standard-compliant cabling to connect Cisco prestandard IP Phones and wireless access points or IEEE 802.3af-compliant devices. You must remove any cable or device that causes a PoE fault.

10/100/1000 Ethernet Port Connections

The switch 10/100/1000 Ethernet port configuration changes to operate at the speed of the attached device. If the attached ports do not support autonegotiation, you can manually set the speed and duplex parameters. Connecting devices that do not autonegotiate or that have the speed and duplex parameters manually set can reduce performance or result in no linkage.

To maximize performance, choose one of these methods for configuring the Ethernet ports:

- Let the ports autonegotiate both speed and duplex.
- Set the interface speed and duplex parameters on both ends of the connection.

Auto-MDIX Connections

The autonegotiation and the auto-MDIX features are enabled by default on the switch.

With autonegotiation, the switch port configurations change to operate at the speed of the attached device. If the attached device does not support autonegotiation, you can manually set the switch interface speed and duplex parameters.

With auto-MDIX, the switch detects the required cable type for copper Ethernet connections and configures the interface accordingly.

If auto-MDIX is disabled, use the guidelines in this table to select the correct cable.

Table 1: Recommended Ethernet Cables (When Auto-MDIX is Disabled)

Device	Crossover Cable	Straight-Through Cable
Switch to switch	Yes	No
Switch to hub	Yes	No
Switch to computer or server	No	Yes

Device	Crossover Cable	Straight-Through Cable
Switch to router	No	Yes
Switch to IP phone	No	Yes

¹ 100BASE-TX and 1000BASE-T traffic requires twisted four-pair, Category 5 or higher. 10BASE-T traffic can use Category 3 cable or higher.