



Overview

- [Overview, on page 1](#)

Overview

The Cisco Nexus 93360YC-FX2 switch (N9K-C93360YC-FX2) is a 2-rack unit (RU), fixed-port switch designed for deployment in data centers. This switch has the following ports:

- 96 10-/25-Gigabit SFP28 ports
- 12 40/100-Gigabit QSFP28 ports
- Two management ports (one RJ-45 port and one SFP port)
- One console port
- 1 USB port

This switch includes the following user-replaceable components:

- Fan modules (three) with the following airflow choices:
 - Port-side exhaust fan module with blue coloring (NXA-FAN-160CFM-PE)
 - Port-side intake fan module with burgundy coloring (NXA-FAN-160CFM-PI)



Note Each fan module has two rotors. The switch can function normally if one rotor inside the any one fan module fails. In case of more than one rotor failure, the switch will issue a warning and power down in 2 minute.

- Power supply modules (two—One for operations and one for redundancy [1+1]) with the following choices:
 - 1200-W port-side exhaust AC power supply with blue coloring (NXA-PAC-1200W-PE)
 - 1200-W port-side intake AC power supply with burgundy coloring (NXA-PAC-1200W-PI)
 - 1200-W HVAC/HVDC dual-direction airflow power supply with white coloring (N9K-PUV-1200W)
 - 930-W port-side exhaust DC power supply with blue coloring (NXA-PDC-930W-PE)

- 930-W port-side intake DC power supply with burgundy coloring (NXA-PDC-930W-PI)



Note 930-W DC power supply support 1+1 redundancy requires both of the following conditions:

- Ambient temperature of 104°F (40°C) or less and
- Use of 3.5 W QSFP+ transceivers or passive QSFP cables

With higher temperatures or other optics, the switch requires both power supplies for operations without power redundancy.



Note Both power supplies are the same type. Do not mix AC, DC, or HVAC/HVDC power supplies.





Note All fan modules and power supplies must use the same airflow direction. If you are using the 1200-W HVAC/HVDC power supplies, those power supplies automatically use the same airflow direction as used by the fan modules.

Deployment Scheme for SFP-10G-T-X Transceivers

The following figure shows the maximum configuration density of SFP-10G-T-X SFP+ transceivers for this switch.

1	3	5	7	9	11	13	15	17	19	21	23	25	27	29	31	33	35	37	39	41	43	45	47	97	99	101
2	4	6	8	10	12	14	16	18	20	22	24	26	28	30	32	34	36	38	40	42	44	46	48	98	100	102
49	51	53	55	57	59	61	63	65	67	69	71	73	75	77	79	81	83	85	87	89	91	93	95	103	105	107
50	52	54	56	58	60	62	64	66	68	70	72	74	76	78	80	82	84	86	88	90	92	94	96	104	106	108

	<p>Active Port deploying the SFP+ 10GBASE-T transceiver, with max power consumption up to 2.5W.</p> <p>Once configured with “media-type 10g-tx” in NX-OS or “Link Level Policy -> Physical Media Type -> SFP 10G TX” in ACI, these ports can deploy SFP-10G-T-X. Without such configuration, they behave like normal ports.</p>
	<p>Port Shutdown or Active with Passive Copper Cables only (Max. power consumption up to 0.1W).</p> <p>Once 10g-tx is configured on yellow ports, ports to the left, right, top and bottom of the yellow port are referenced as blue ports. These adjacent ports will then support only low power Passive Copper DAC cable, or these can be left empty to conserve power. If 10g-tx configuration is removed from adjacent yellow ports, the blue ports will revert to behaving like normal ports.</p>
	<p>Active Port deploying any Cisco 1/10/25G optics (SFP, SFP+, SFP28) EXCLUDING SFP+ 10GBASE-T, with max power consumption up to 1.5W. These ports are not part of any scheme and can deploy all regular Cisco optics and behave like normal ports.</p>

	Active Uplink QSFP+, QSFP28 ports with Incoming and outgoing traffic (40G/100G).
--	--

The following figure shows the switch features on the port side of the chassis.

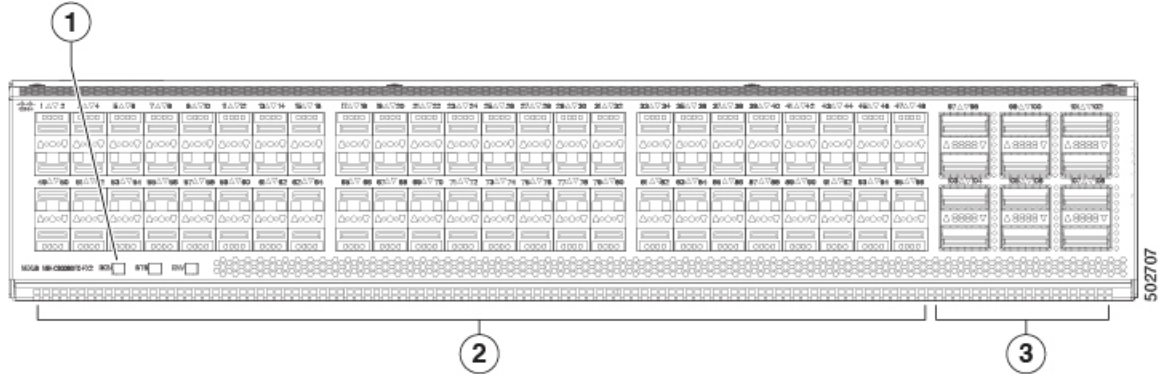

1	Beacon (BCN), Status (STS), and Environment (ENV) LEDs	3	12 40/100-Gigabit QSFP28 ports
2	96 10-/25-Gigabit SFP28 ports		

To determine which transceivers, adapters, and cables are support this switch, see the [Cisco Transceiver Modules Compatibility Information](#) document.

The following figure shows the switch features on the power supply side of the chassis.

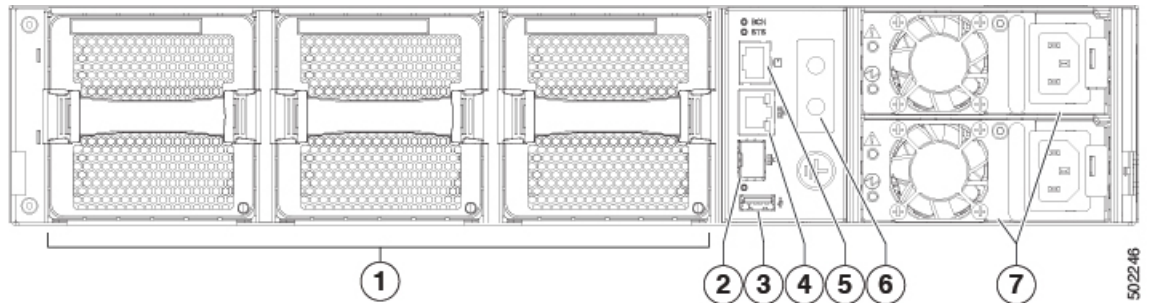

1	Fan modules (3) with slots numbered from 1 (left) to 3 (right)	5	Console port (1)
2	Management port (1—SFP optical port)	6	Grounding pad
3	USB port (1)	7	Power supply modules (1 or 2) (AC power supplies shown) with slots numbered 1 (top) and 2 (bottom)
4	Management port (1—RJ-45 copper port)		

The following figure shows the side of the chassis.

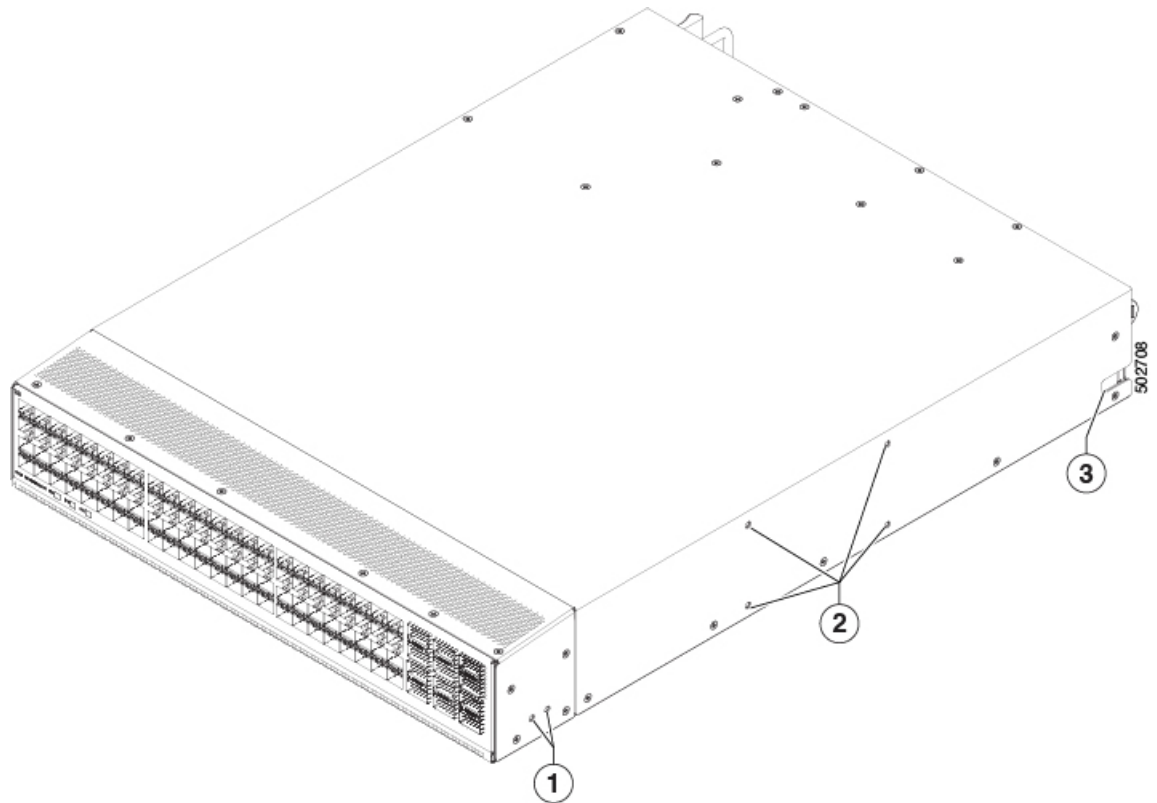

1	Screw holes for front mounting brackets (4-post rack installations)	3	Notch on both sides of the chassis for locking the power supply end of the chassis to the bottom support rails (4-post rack installations).
2	Screw holes for center-mount bracket (2-post rack installations)		

Depending on whether you plan to position the ports in a hot or cold aisle, you can order the fan and power supply modules with port-side intake or port-side exhaust airflow. For port-side intake airflow, the fan and AC power supply modules have burgundy coloring. For port-side exhaust airflow, the fan and AC power supplies have blue coloring. You can also order the 1200-W HVAC/HVDC power supply which has dual-direction airflow with white coloring. Dual-direction airflow modules automatically use the airflow direction of the other modules installed in the switch.

The fan and power supply modules are field replaceable. You can replace one fan module or one power supply module during operations so long as the other modules are installed and operating. If you have only one power supply installed, you can install the replacement power supply in the open slot before removing the original power supply.



Note All fan and power supply modules must have the same direction of airflow. Otherwise, the switch can overheat and shut down. If you are installing a dual-direction power supply, that module automatically uses the same airflow direction as the other modules in the switch.

**Caution**

If the switch has port-side intake airflow (burgundy coloring for fan modules), you must locate the ports in the cold aisle. If the switch has port-side exhaust airflow (blue coloring for fan modules), you must locate the ports in the hot aisle. If you locate the air intake in a hot aisle, the switch can overheat and shut down.

