



Cisco Nexus 93108TC-EX NX-OS Mode Switch Hardware Installation Guide

First Published: 2016-08-04

Last Modified: 2018-10-19

Americas Headquarters

Cisco Systems, Inc.
170 West Tasman Drive
San Jose, CA 95134-1706
USA
<http://www.cisco.com>
Tel: 408 526-4000
800 553-NETS (6387)
Fax: 408 527-0883

THE SPECIFICATIONS AND INFORMATION REGARDING THE PRODUCTS IN THIS MANUAL ARE SUBJECT TO CHANGE WITHOUT NOTICE. ALL STATEMENTS, INFORMATION, AND RECOMMENDATIONS IN THIS MANUAL ARE BELIEVED TO BE ACCURATE BUT ARE PRESENTED WITHOUT WARRANTY OF ANY KIND, EXPRESS OR IMPLIED. USERS MUST TAKE FULL RESPONSIBILITY FOR THEIR APPLICATION OF ANY PRODUCTS.

THE SOFTWARE LICENSE AND LIMITED WARRANTY FOR THE ACCOMPANYING PRODUCT ARE SET FORTH IN THE INFORMATION PACKET THAT SHIPPED WITH THE PRODUCT AND ARE INCORPORATED HEREIN BY THIS REFERENCE. IF YOU ARE UNABLE TO LOCATE THE SOFTWARE LICENSE OR LIMITED WARRANTY, CONTACT YOUR CISCO REPRESENTATIVE FOR A COPY.

The following information is for FCC compliance of Class A devices: This equipment has been tested and found to comply with the limits for a Class A digital device, pursuant to part 15 of the FCC rules. These limits are designed to provide reasonable protection against harmful interference when the equipment is operated in a commercial environment. This equipment generates, uses, and can radiate radio-frequency energy and, if not installed and used in accordance with the instruction manual, may cause harmful interference to radio communications. Operation of this equipment in a residential area is likely to cause harmful interference, in which case users will be required to correct the interference at their own expense.

The following information is for FCC compliance of Class B devices: This equipment has been tested and found to comply with the limits for a Class B digital device, pursuant to part 15 of the FCC rules. These limits are designed to provide reasonable protection against harmful interference in a residential installation. This equipment generates, uses and can radiate radio frequency energy and, if not installed and used in accordance with the instructions, may cause harmful interference to radio communications. However, there is no guarantee that interference will not occur in a particular installation. If the equipment causes interference to radio or television reception, which can be determined by turning the equipment off and on, users are encouraged to try to correct the interference by using one or more of the following measures:

- Reorient or relocate the receiving antenna.
- Increase the separation between the equipment and receiver.
- Connect the equipment into an outlet on a circuit different from that to which the receiver is connected.
- Consult the dealer or an experienced radio/TV technician for help.

Modifications to this product not authorized by Cisco could void the FCC approval and negate your authority to operate the product

The Cisco implementation of TCP header compression is an adaptation of a program developed by the University of California, Berkeley (UCB) as part of UCB's public domain version of the UNIX operating system. All rights reserved. Copyright © 1981, Regents of the University of California.

NOTWITHSTANDING ANY OTHER WARRANTY HEREIN, ALL DOCUMENT FILES AND SOFTWARE OF THESE SUPPLIERS ARE PROVIDED "AS IS" WITH ALL FAULTS. CISCO AND THE ABOVE-NAMED SUPPLIERS DISCLAIM ALL WARRANTIES, EXPRESSED OR IMPLIED, INCLUDING, WITHOUT LIMITATION, THOSE OF MERCHANTABILITY, FITNESS FOR A PARTICULAR PURPOSE AND NONINFRINGEMENT OR ARISING FROM A COURSE OF DEALING, USAGE, OR TRADE PRACTICE.

IN NO EVENT SHALL CISCO OR ITS SUPPLIERS BE LIABLE FOR ANY INDIRECT, SPECIAL, CONSEQUENTIAL, OR INCIDENTAL DAMAGES, INCLUDING, WITHOUT LIMITATION, LOST PROFITS OR LOSS OR DAMAGE TO DATA ARISING OUT OF THE USE OR INABILITY TO USE THIS MANUAL, EVEN IF CISCO OR ITS SUPPLIERS HAVE BEEN ADVISED OF THE POSSIBILITY OF SUCH DAMAGES.

Any Internet Protocol (IP) addresses and phone numbers used in this document are not intended to be actual addresses and phone numbers. Any examples, command display output, network topology diagrams, and other figures included in the document are shown for illustrative purposes only. Any use of actual IP addresses or phone numbers in illustrative content is unintentional and coincidental.

Cisco and the Cisco logo are trademarks or registered trademarks of Cisco and/or its affiliates in the U.S. and other countries. To view a list of Cisco trademarks, go to this URL: <https://www.cisco.com/c/en/us/about/legal/trademarks.html>. Third-party trademarks mentioned are the property of their respective owners. The use of the word partner does not imply a partnership relationship between Cisco and any other company. (1721R)

© 2016–2017 Cisco Systems, Inc. All rights reserved.



CONTENTS

Trademarks ?

PREFACE

Preface vii

Audience vii

Documentation Conventions vii

Related Documentation for Cisco Nexus 9000 Series NX-OS Software viii

Documentation Feedback x

Obtaining Documentation and Submitting a Service Request x

CHAPTER 1

Overview 1

Overview 1

CHAPTER 2

Preparing the Site 5

Temperature Requirements 5

Humidity Requirements 5

Altitude Requirements 5

Dust and Particulate Requirements 6

Minimizing Electromagnetic and Radio Frequency Interference 6

Shock and Vibration Requirements 7

Grounding Requirements 7

Planning for Power Requirements 7

Airflow Requirements 9

Rack and Cabinet Requirements 10

Clearance Requirements 11

CHAPTER 3

Installing the Switch Chassis 13

Safety 13

Installation Options with Rack-Mount Kits 14

Airflow Considerations 14

Installation Guidelines 14

Unpacking and Inspecting the Switch 16

Installing the Switch Using the NXX-ACC-KIT-1RU Rack-Mount Kit 17

Installing the Switch Using the N3K-C3064-ACC-KIT Rack-Mount Kit 20

Grounding the Chassis 24

Starting the Switch 26

CHAPTER 4 **Connecting the Switch to the Network 29**

 Overview of Network Connections 29

 Connecting a Console to the Switch 29

 Creating the Initial Switch Configuration 31

 Setting Up the Management Interface 32

 Connecting Interface Ports to Other Devices 33

 Uplink Connections 33

 Downlink Connections 33

CHAPTER 5 **Replacing Modules 35**

 Replacing a Fan Module 35

 Removing a Fan Module 35

 Installing a Fan Module 36

 Replacing a Power Supply Module 36

 Removing an AC Power Supply 36

 Removing an HVAC/HVDC Power Supply 37

 Removing a DC Power Supply 38

 Installing an AC Power Supply 38

 Installing an HVAC/HVDC Power Supply 39

 Installing a DC Power Supply 40

 Wiring a 48 V DC Electrical Connector Block 41

APPENDIX A **Rack Specifications 43**

 Overview of Racks 43

General Requirements for Cabinets and Racks	43
Requirements Specific to Standard Open Racks	44
Requirements Specific to Perforated Cabinets	44
Cable Management Guidelines	44

APPENDIX B**System Specifications 45**

Environmental Specifications	45
Switch Dimensions	45
Switch and Module Weights and Quantities	46
Transceiver and Cable Specifications	46
Switch Power Input Requirements	46
Power Specifications	47
650-W AC Power Supply Specifications	47
1200-W HVAC/HVDC Power Supply Specifications	47
930-W DC Power Supply (Port-Side Intake) Specifications	48
930-W DC Power Supply (Port-Side Exhaust) Specifications	48
930-W DC Power Supply Specifications	49
Power Cable Specifications	50
AC Power Cables Supported by NX-OS Mode Switches	50
HVAC/HVDC Power Cables Supported by ACI-Mode and NX-OS Mode Switches	51
DC Power Cable Specifications	52
Regulatory Standards Compliance Specifications	52

APPENDIX C**LEDs 55**

Switch Chassis LEDs	55
Fan Module LEDs	56
Power Supply LEDs	56

APPENDIX D**Additional Kits 59**

Rack Mount Kit NXK-ACC-KIT-1RU	59
Rack Mount Kit N3K-C3064-ACC-KIT	60

APPENDIX E**Site Preparation and Maintenance Records 61**

Site Preparation Checklist	61
----------------------------	----

Contact and Site Information 62

Chassis and Module Information 63



Preface

- [Audience, on page vii](#)
- [Documentation Conventions, on page vii](#)
- [Related Documentation for Cisco Nexus 9000 Series NX-OS Software, on page viii](#)
- [Documentation Feedback, on page x](#)
- [Obtaining Documentation and Submitting a Service Request, on page x](#)

Audience

This publication is for hardware installers and network administrators who install, configure, and maintain Cisco Nexus switches.

Documentation Conventions

Command descriptions use the following conventions:

Convention	Description
bold	Bold text indicates the commands and keywords that you enter literally as shown.
<i>Italic</i>	Italic text indicates arguments for which the user supplies the values.
[x]	Square brackets enclose an optional element (keyword or argument).
[x y]	Square brackets enclosing keywords or arguments separated by a vertical bar indicate an optional choice.
{x y}	Braces enclosing keywords or arguments separated by a vertical bar indicate a required choice.
[x {y z}]	Nested set of square brackets or braces indicate optional or required choices within optional or required elements. Braces and a vertical bar within square brackets indicate a required choice within an optional element.
variable	Indicates a variable for which you supply values, in context where italics cannot be used.

Convention	Description
string	A nonquoted set of characters. Do not use quotation marks around the string or the string will include the quotation marks.

Examples use the following conventions:

Convention	Description
screen font	Terminal sessions and information the switch displays are in screen font.
boldface screen font	Information you must enter is in boldface screen font.
<i>italic screen font</i>	Arguments for which you supply values are in italic screen font.
< >	Nonprinting characters, such as passwords, are in angle brackets.
[]	Default responses to system prompts are in square brackets.
!, #	An exclamation point (!) or a pound sign (#) at the beginning of a line of code indicates a comment line.

Related Documentation for Cisco Nexus 9000 Series NX-OS Software

The entire Cisco NX-OS 9000 Series documentation set is available at the following URL:

https://www.cisco.com/en/US/products/ps13386/tsd_products_support_series_home.html

Release Notes

The release notes are available at the following URL:

https://www.cisco.com/en/US/products/ps13386/prod_release_notes_list.html

Configuration Guides

These guides are available at the following URL:

https://www.cisco.com/en/US/products/ps13386/products_installation_and_configuration_guides_list.html

The documents in this category include:

- *Cisco Nexus 2000 Series NX-OS Fabric Extender Software Configuration Guide for Cisco Nexus 9000 Series Switches*
- *Cisco Nexus 9000 Series NX-OS Fundamentals Configuration Guide*
- *Cisco Nexus 9000 Series NX-OS High Availability and Redundancy Guide*
- *Cisco Nexus 9000 Series NX-OS Interfaces Configuration Guide*
- *Cisco Nexus 9000 Series NX-OS Layer 2 Switching Configuration Guide*
- *Cisco Nexus 9000 Series NX-OS Multicast Routing Configuration Guide*

- *Cisco Nexus 9000 Series NX-OS Quality of Service Configuration Guide*
- *Cisco Nexus 9000 Series NX-OS Security Configuration Guide*
- *Cisco Nexus 9000 Series NX-OS System Management Configuration Guide*
- *Cisco Nexus 9000 Series NX-OS Unicast Routing Configuration Guide*
- *Cisco Nexus 9000 Series NX-OS Verified Scalability Guide*
- *Cisco Nexus 9000 Series NX-OS VXLAN Configuration Guide*

Other Software Documents

- *Cisco Nexus 7000 Series and 9000 Series NX-OS MIB Quick Reference*
- *Cisco Nexus 9000 Series NX-OS Programmability Guide*
- *Cisco Nexus 9000 Series NX-OS Software Upgrade and Downgrade Guide*
- *Cisco Nexus 9000 Series NX-OS System Messages Reference*
- *Cisco Nexus 9000 Series NX-OS Troubleshooting Guide*
- *Cisco NX-OS Licensing Guide*
- *Cisco NX-OS XML Interface User Guide*

Hardware Documents

- *Cisco Nexus 3000 Series Hardware Installation Guide*
- *Cisco Nexus 92160YC-X NX-OS Mode Switch Hardware Installation Guide*
- *Cisco Nexus 92300YC NX-OS Mode Switch Hardware Installation Guide*
- *Cisco Nexus 92304QC NX-OS Mode Switch Hardware Installation Guide*
- *Cisco Nexus 9236C NX-OS Mode Switch Hardware Installation Guide*
- *Cisco Nexus 9272Q NX-OS Mode Switch Hardware Installation Guide*
- *Cisco Nexus 93108TC-EX NX-OS Mode Switch Hardware Installation Guide*
- *Cisco Nexus 93120TX NX-OS Mode Switch Hardware Installation Guide*
- *Cisco Nexus 93128TX NX-OS Mode Switch Hardware Installation Guide*
- *Cisco Nexus 93180LC-EX NX-OS Mode Switch Hardware Installation Guide*
- *Cisco Nexus 93180YC-EX NX-OS Mode Switch Hardware Installation Guide*
- *Cisco Nexus 9332PQ NX-OS-Mode Switch Hardware Installation Guide*
- *Cisco Nexus 9372PX and 9372PX-E NX-OS Mode Switches Hardware Installation Guide*
- *Cisco Nexus 9372TX and 9372TX-E NX-OS Mode Switches Hardware Installation Guide*
- *Cisco Nexus 9396PX NX-OS Mode Switch Hardware Installation Guide*

- *Cisco Nexus 9396TX NX-OS Mode Switch Hardware Installation Guide*
- *Cisco Nexus 9504 NX-OS Mode Switch Hardware Installation Guide*
- *Cisco Nexus 9508 NX-OS Mode Switch Hardware Installation Guide*
- *Cisco Nexus 9516 NX-OS Mode Switch Hardware Installation Guide*
- *Regulatory, Compliance, and Safety Information for the Cisco Nexus 3000 and 9000 Series*

Documentation Feedback

To provide technical feedback on this document, or to report an error or omission, please send your comments to nexus9k-docfeedback@cisco.com. We appreciate your feedback.

Obtaining Documentation and Submitting a Service Request

For information on obtaining documentation, using the Cisco Bug Search Tool (BST), submitting a service request, and gathering additional information, see *What's New in Cisco Product Documentation*, at: <https://www.cisco.com/warp/public/687/Directory/DirTAC.shtml>.

Subscribe to *What's New in Cisco Product Documentation*, which lists all new and revised Cisco technical documentation as an RSS feed and delivers content directly to your desktop using a reader application. The RSS feeds are a free service.



CHAPTER 1

Overview

- [Overview, on page 1](#)

Overview

The Cisco Nexus 93108TC-EX switch (N9K-C93108TC-EX) is a 1-RU, fixed-port switch designed for Top-of-Rack (ToR), Middle-of-Rack (MoR), and End-of-Rack (EoR) deployment in data centers. This switch has 48 10GBASE-T ports for downlink connections and six fixed 40/100-Gigabit QSFP28 (optical) ports for uplink connections. The 10GBASE-T ports support 100 Megabit, 1-Gigabit, and 10-Gigabit speeds, and the QSFP28 ports support 1-, 10-, 25-, 40-, and 100-Gigabit speeds.

The chassis for this switch includes the following user-replaceable components:



Note You can order this switch in a 24-port configuration (N9K-C93108TC-EX-24)

- Fan modules (four) with the following airflow choices:
 - Port-side intake airflow with burgundy coloring (NXA-FAN-30CFM-B)
 - Port-side exhaust airflow with blue coloring (NXA-FAN-30CFM-F)
- Power supply modules (two—One for operations and one for redundancy [1+1]) with the following choices:
 - 650-W AC power supply with port-side intake airflow (burgundy coloring) (NXA-PAC-650W-PI)
 - 650-W AC power supply with port-side exhaust airflow (blue coloring) (NXA-PAC-650W-PE)
 - 1200-W HVAC/HVDC power supply with dual-direction airflow (white coloring) (N9K-PUV-1200W)
 - 930-W DC power supply with port-side exhaust airflow (gray coloring) (UCS-PSU-6332-DC)
 - 930-W DC power supply with port-side intake airflow (green coloring) (UCSC-PSU-930WDC)
 - 930-W DC power supply with port-side intake airflow (burgundy coloring) (NXA-PDC-930W-PI)
 - 930-W DC power supply with port-side exhaust airflow (blue coloring) (NXA-PDC-930W-PE)



Note Both power supplies must be the same type. Do not mix AC, DC, or HVAC/HVDC power supplies.



Note All fan modules and power supplies must use the same airflow direction during operations. If you are using the 1200-W HVAC/HVDC power supplies, those power supplies automatically use the same airflow direction as used by the other modules in the switch.

The following figure shows the hardware features seen from the port side of the chassis.

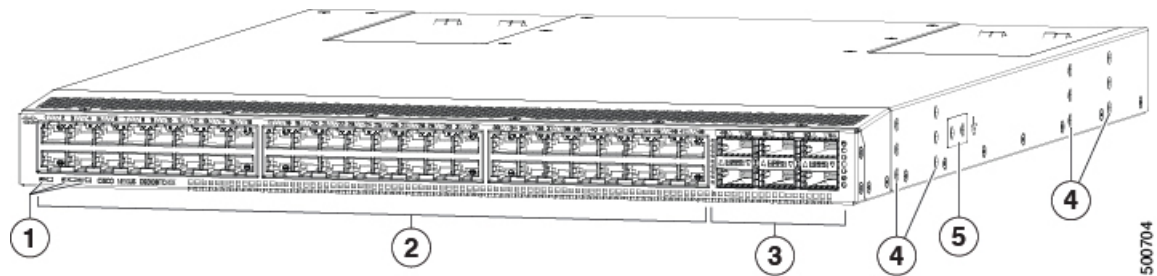

1	Chassis LEDs (Beacon [BCN], Status [STA], and Environment [ENV])	4	Screw holes (6) for attaching rack mounting brackets
2	48 10GBASE-T downlink ports	5	Screw holes (2) for attaching grounding lug
3	6 40/100-Gigabit QSFP28 optical uplink ports		

To determine which transceivers, adapters, and cables this switch supports, see the [Cisco Transceiver Modules Compatibility Information](#) document.

The following figure shows the hardware features seen from the power supply side of the chassis.

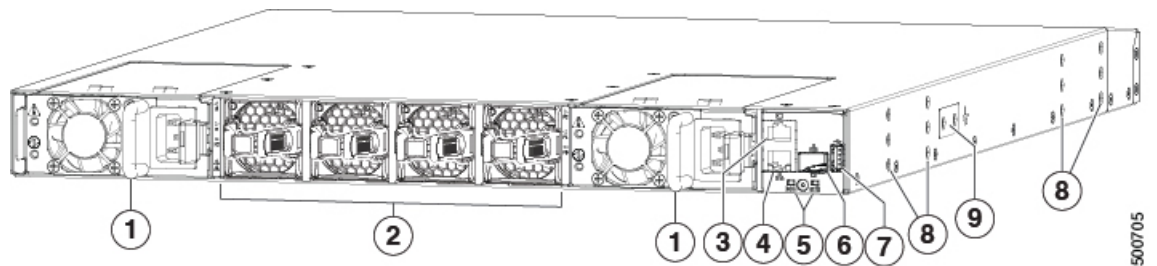

1	2 power supplies (AC power supplies shown) with power supply slot 1 on the left and slot 2 on the right	6	Out-of-band management port (SFP port)
2	4 fan modules with fan slot 1 on the left and fan slot 4 on the right	7	USB port that is used for saving or copying functions

3	Console port (RS232 port)	8	Screw holes (6) for attaching rack mounting brackets
4	Out-of-band management port (RJ-45 port)	9	Screw holes (2) for attaching grounding lug
5	Chassis LEDs (Beacon [BCN] and Status [STA])		



Note There is a limit to USB 2.0 devices that use less than 2.5 W (less than 0.5 A inclusive of surge current). There is no support for devices, such as external hard drives, that instantaneously draw more than 0.5 A.

Depending on whether you plan to position the ports in a hot or cold aisle, you can order the fan and power supply modules with port-side intake or port-side exhaust airflow. To determine the airflow direction of the modules installed in your switch, see the following table.

Replaceable Modules	Port-Side Intake Airflow Coloring	Port-Side Exhaust Airflow Coloring
Fans	Burgundy	Blue
AC power supplies	Burgundy	Blue
HVAC/HVDC power supplies	White	
DC power supplies	Green	Gray

The fan and power supply modules are field replaceable and you can replace one fan module or one power supply module during operations so long as the other modules are operating. If you have only one power supply that is installed, you can install the replacement power supply in the open slot before removing the original power supply.



Note Fans and power supply modules must have the same direction of airflow. Otherwise, the switch can overheat and shut down. If you are installing a dual-direction power supply, that module will automatically use the same airflow direction as the other modules in the switch.



Caution If the switch has port-side intake airflow (burgundy coloring for fan modules), you must locate the ports in the cold aisle. If the switch has port-side exhaust airflow (blue coloring for fan modules), you must locate the ports in the hot aisle. If you locate the air intake in a hot aisle, the switch can overheat and shut down.

The switch supports the Fabric Extenders (FEXs) listed at <https://www.cisco.com/c/en/us/td/docs/switches/datacenter/nexus9000/hw/interoperability/fexmatrix/fextables.html>.



CHAPTER 2

Preparing the Site

- [Temperature Requirements, on page 5](#)
- [Humidity Requirements, on page 5](#)
- [Altitude Requirements, on page 5](#)
- [Dust and Particulate Requirements, on page 6](#)
- [Minimizing Electromagnetic and Radio Frequency Interference, on page 6](#)
- [Shock and Vibration Requirements, on page 7](#)
- [Grounding Requirements, on page 7](#)
- [Planning for Power Requirements, on page 7](#)
- [Airflow Requirements, on page 9](#)
- [Rack and Cabinet Requirements, on page 10](#)
- [Clearance Requirements, on page 11](#)

Temperature Requirements

The switch requires an operating temperature of 32 to 104 degrees Fahrenheit (0 to 40 degrees Celsius). If the switch is not operating, the temperature must be between –40 to 158 degrees Fahrenheit (–40 to 70 degrees Celsius).

Humidity Requirements

High humidity can cause moisture to enter the switch. Moisture can cause corrosion of internal components and degradation of properties such as electrical resistance, thermal conductivity, physical strength, and size. The switch is rated to withstand from 5- to 95-percent (noncondensing) relative humidity.

Buildings in which the climate is controlled by air-conditioning in the warmer months and by heat during the colder months usually maintain an acceptable level of humidity for the switch equipment. However, if the switch is located in an unusually humid location, use a dehumidifier to maintain the humidity within an acceptable range.

Altitude Requirements

Altitude rating is based on power supply installed; see critical components list in the system CB report for altitude rating.

Dust and Particulate Requirements

Exhaust fans cool power supplies and system fans cool switches by drawing in air and exhausting air out through various openings in the chassis. However, fans also ingest dust and other particles, causing contaminant buildup in the switch and increased internal chassis temperature. Dust and particles can act as insulators and interfere with the mechanical components in the switch. A clean operating environment can greatly reduce the negative effects of dust and other particles.

In addition to keeping your environment free of dust and particles, follow these precautions to avoid contamination of your switch:

- Do not permit smoking near the switch.
- Do not permit food or drink near the switch.

Minimizing Electromagnetic and Radio Frequency Interference

Electromagnetic interference (EMI) and radio frequency interference (RFI) from the switch can adversely affect other devices, such as radio and television (TV) receivers. Radio frequencies that emanate from the switch can also interfere with cordless and low-power telephones. Conversely, RFI from high-power telephones can cause spurious characters to appear on the switch monitor.

RFI is defined as any EMI with a frequency above 10 kHz. This type of interference can travel from the switch to other devices through the power cable and power source or through the air as transmitted radio waves. The Federal Communications Commission (FCC) publishes specific regulations to limit the amount of EMI and RFI that are emitted by computing equipment. Each switch meets these FCC regulations.

To reduce the possibility of EMI and RFI, follow these guidelines:

- Cover all open expansion slots with a blank filler plate.
- Always use shielded cables with metal connector shells for attaching peripherals to the switch.

When wires are run for any significant distance in an electromagnetic field, interference can occur to the signals on the wires with the following implications:

- Bad wiring can result in radio interference emanating from the plant wiring.
- Strong EMI, especially when it is caused by lightning or radio transmitters, can destroy the signal drivers and receivers in the chassis and even create an electrical hazard by conducting power surges through lines into equipment.



Note

To predict and prevent strong EMI, you need to consult experts in radio frequency interference (RFI).

The wiring is unlikely to emit radio interference if you use a twisted-pair cable with a good distribution of grounding conductors. If you exceed the recommended distances, use a high-quality twisted-pair cable with one ground conductor for each data signal when applicable.

**Caution**

If the wires exceed the recommended distances, or if wires pass between buildings, give special consideration to the effect of a lightning strike in your vicinity. The electromagnetic pulse that is caused by lightning or other high-energy phenomena can easily couple enough energy into unshielded conductors to destroy electronic switches. You will want to consult experts in electrical surge suppression and shielding if you had similar problems in the past.

Shock and Vibration Requirements

The switch has been shock- and vibration-tested for operating ranges, handling, and earthquake standards.

Grounding Requirements

The switch is sensitive to variations in voltage that is supplied by the power sources. Overvoltage, undervoltage, and transients (or spikes) can erase data from memory or cause components to fail. To protect against these types of problems, ensure that there is an earth-ground connection for the switch. You can connect the grounding pad on the switch either directly to the earth-ground connection or to a fully bonded and grounded rack.

When you properly install the chassis in a grounded rack, the switch is grounded because it has a metal-to-metal connection to the rack. Alternatively, you can ground the chassis by using a customer-supplied grounding cable that meets your local and national installation requirements. For U.S. installations, we recommend 6-AWG wire. Connect your grounding cable to the chassis with a grounding lug (provided in the switch accessory kit) and to the facility ground.

**Note**

You automatically ground AC power supplies when you connect them to AC power sources. For DC power supplies, you must connect a grounding wire when wiring the power supply to the DC power source.

**Note**

An electrical conducting path shall exist between the product chassis and the metal surface of the enclosure or rack in which it is mounted or to a grounding conductor. Electrical continuity shall be provided by using thread-forming type mounting screws that remove any paint or non-conductive coatings and establish a metal-to-metal contact. Any paint or other non-conductive coatings shall be removed on the surfaces between the mounting hardware and the enclosure or rack. The surfaces shall be cleaned and an antioxidant applied before installation.

Planning for Power Requirements

The switch includes two power supplies (1-to-1 redundancy with current sharing) in one of the following combinations:

- Two 650-W AC power supplies (NEBS compliant)
- Two 1200-W HVAC/HVDC power supplies

- Two 930-W DC power supplies



Note Both power supplies must be the same type. Do not mix AC, DC, and HVAC/HVDC power supplies in the same chassis.



Note For $n+1$ redundancy, you can use one or two power sources for the two power supplies. For $n+n$ redundancy, you must use two power sources and connect each power supply to a separate power source.

The power supplies are rated to output up to 650 W (AC power supplies), up to 1200 W (HVAC/HVDC power supplies), or up to 930 W (DC power supplies), but the switch requires less than those amounts of power from the power supply. To operate the switch, you must provision enough power from the power source to cover the requirements of both the switch and a power supply. Typically, this switch and a power supply require 290 W of power input from the power source, but you must provision as much as 499 W of power input from the power source to cover peak demand.



Note Some of the power supply modules have rating capabilities that exceed the switch requirements. When calculating your power requirements, use the switch requirements to determine the amount of power that is required for the power supplies.

To minimize the possibility of circuit failure, make sure that each power-source circuit that is used by the switch is dedicated to the switch.



Note For AC input application, please refer to the following statement:



Warning **Statement 1005**—Circuit Breaker

This product relies on the building's installation for short-circuit (overcurrent) protection. Ensure that the protective devices are rated not greater than 20A (North America), 16A (Europe), and 13A (UK).



Note For DC input application, please refer to the following statement:

**Warning Statement 1005**—Circuit Breaker

This product relies on the building's installation for short-circuit (overcurrent) protection.

- Ensure that the protective devices are rated not greater than 30A when the switch is powered with regular DC power supplies (rated 48-60VDC).
- Ensure that the protective devices are rated not greater than 10A when the switch is powered with HVDC power supplies (rated 240-350VDC).

**Warning Statement 1033**

Connect the unit only to DC power source that complies with the Safety Extra-Low Voltage (SELV) requirements in IEC 60950 based safety standards.



Note We recommend 8-AWG wire for DC installations in the U.S.



Note For the power cables to use with the power supplies, see [Power Cable Specifications, on page 50](#).

Airflow Requirements

The switch is positioned with its ports in either the front or the rear of the rack depending on your cabling and maintenance requirements. You must have fan and power supply modules that move the coolant air from the cold aisle to the hot aisle in one of the following ways:

- Port-side exhaust airflow—Cool air enters the chassis through the fan and power supply modules in the cold aisle and exhausts through the port end of the chassis in the hot aisle.
- Port-side intake airflow—Cool air enters the chassis through the port end in the cold aisle and exhausts through the fan and power supply modules in the hot aisle.
- Dual-direction airflow—The direction of the installed fan modules determines the airflow.

You can identify the airflow direction of each fan and power supply module by its coloring as follows:

- Blue coloring indicates port-side exhaust airflow.
- Burgundy coloring indicates port-side intake airflow.
- White coloring on HVAC/HVDC power supplies indicates dual-direction airflow.
- Gray coloring on DC power supplies indicates port-side exhaust airflow.
- Green coloring on DC power supplies indicates port-side intake airflow.



Note To prevent the switch from overheating and shutting down, you must position the air intake for the switch in a cold aisle. The fan and power supply modules must have the same direction of airflow (even if their coloring is different). If you must change the airflow direction for the switch, you must shutdown the switch before changing the modules.

Rack and Cabinet Requirements

You can install the following types of racks or cabinets for your switch:

- Standard perforated cabinets
- Solid-walled cabinets with a roof fan tray (bottom-to-top cooling)
- Standard open four-post Telco racks

Work with your cabinet vendors to determine which of their cabinets meet the following requirements or see the Cisco Technical Assistance Center (TAC) for recommendations:

- Use a standard 19-inch (48.3-cm), four-post Electronic Industries Alliance (EIA) cabinet or rack with mounting rails that conform to English universal hole spacing per section 1 of the ANSI/EIA-310-D-1992 standard.
- The depth of a four-post rack must be 24 to 32 inches (61.0 to 81.3 cm) between the front and rear mounting rails (for proper mounting of the bottom-support brackets or other mounting hardware).
- Required clearances between the chassis and the edges of its rack or the interior of its cabinet are as follows:
 - 4.5 inches (11.4 cm) between the front of the chassis and the interior of the cabinet (required for cabling).
 - 3.0 inches (7.6 cm) between the rear of the chassis and the interior of the cabinet (required for airflow in the cabinet if used).
 - No clearance is required between the chassis and the sides of the rack or cabinet (no side airflow).

Also, you must have power receptacles that are located within reach of the power cords that are used with the switch.



Warning **Statement 1048**—Rack Stabilization

The rack stabilizing mechanism must be in place, or the rack must be bolted to the floor before installation or servicing. Failure to stabilize the rack can cause bodily injury.

Clearance Requirements

Provide the chassis with adequate clearance between the chassis and any other rack, device, or structure so that you can properly install the chassis. Provide the chassis with adequate clearance to route cables, provide airflow, and maintain the switch. For the clearances required for an installation of this chassis in a four-post rack, see the following figure.

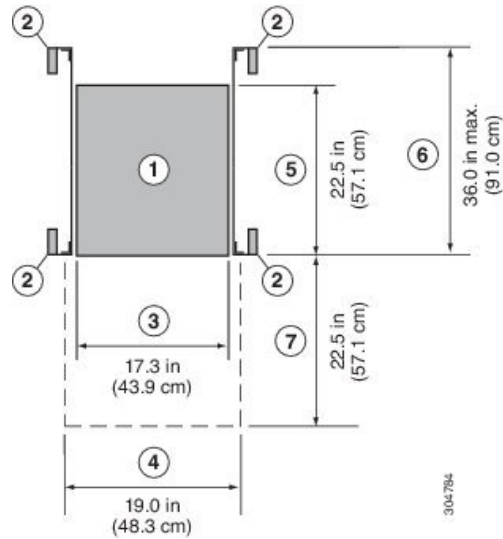

1	Chassis	5	Depth of the chassis
2	Vertical rack-mount posts and rails	6	Maximum extension of the bottom-support rails
3	Chassis width	7	Depth of the front clearance area (equal to the depth of the chassis).
4	Width of the front clearance area (equal to the width of the chassis with two rack-mount brackets that are attached to it).		



Note Both the front and rear of the chassis must be open to both aisles for airflow.



CHAPTER 3

Installing the Switch Chassis

- [Safety](#), on page 13
- [Installation Options with Rack-Mount Kits](#), on page 14
- [Airflow Considerations](#), on page 14
- [Installation Guidelines](#), on page 14
- [Unpacking and Inspecting the Switch](#), on page 16
- [Installing the Switch Using the NXK-ACC-KIT-1RU Rack-Mount Kit](#), on page 17
- [Installing the Switch Using the N3K-C3064-ACC-KIT Rack-Mount Kit](#), on page 20
- [Grounding the Chassis](#), on page 24
- [Starting the Switch](#), on page 26

Safety

Before you install, operate, or service the switch, see the *Regulatory, Compliance, and Safety Information for the Cisco Nexus 3000 and 9000 Series* for important Safety Information.



Warning

Statement 1071—Warning Definition

IMPORTANT SAFETY INSTRUCTIONS

This warning symbol means danger. You are in a situation that could cause bodily injury. Before you work on any equipment, be aware of the hazards involved with electrical circuitry and be familiar with standard practices for preventing accidents. Use the statement number provided at the end of each warning to locate its translation in the translated safety warnings that accompanied this device.

SAVE THESE INSTRUCTIONS





Warning **Statement 1017**—Restricted Area

This unit is intended for installation in restricted access areas. A restricted access area can be accessed by skilled, instructed or qualified personnel.



Warning **Statement 1030**—Equipment Installation

Only trained and qualified personnel should be allowed to install, replace, or service this equipment.

Installation Options with Rack-Mount Kits

The rack-mount kit enables you to install the switch into racks of varying depths. You can position the switch with easy access to either the port connections or the fan and power supply modules.

You can install the switch using the following rack-mount options:

- Rack-mount kit (NXK-ACC-KIT-1RU) which you can order from Cisco. This option offers you easy installation, greater stability, increased weight capacity, added accessibility, and improved removability with front and rear removal.
- Rack-mount kit (N3K-C3064-ACC-KIT) which you can order from Cisco.

The rack or cabinet that you use must meet the requirements listed the in [General Requirements for Cabinets and Racks](#), on page 43 section.



Note You are responsible for verifying that your rack and rack-mount hardware comply with the guidelines that are described in this doc.

Airflow Considerations

The switch comes with fan and power supply modules that have either port-side intake or port-side exhaust airflow for cooling the switch. If you are positioning the port end of the switch in a cold aisle, make sure that the switch has port-side intake fan modules with burgundy coloring. If you are positioning the fan and power supply modules in a cold aisle, make sure that the switch has port-side exhaust fan modules with blue colorings. All fan modules must have the same direction of airflow.

Installation Guidelines

When installing the switch, follow these guidelines:

- Ensure that there is adequate clearance space around the switch to allow for servicing the switch and for adequate airflow.

- Ensure that you are positioning the switch in a rack so that it takes in cold air from the cold aisle and exhausts air to the hot aisle. If there is blue coloring on the fan modules, the switch is configured for port-side exhaust airflow and you must position the module side of the switch in a cold aisle. If there is burgundy coloring on the fan modules, the switch is configured for port-side intake airflow and you must position the port side of the switch in a cold aisle.
- Ensure that the chassis can be adequately grounded. If the switch is not mounted in a grounded rack, we recommend connecting the system ground on the chassis directly to an earth ground.
- Ensure that the site power meets the power requirements for the switch. If available, you can use an uninterruptible power supply (UPS) to protect against power failures.



Caution Avoid UPS types that use ferroresonant technology. These UPS types can become unstable with the switch, which can have substantial current draw fluctuations because of fluctuating data traffic patterns.

- Ensure that circuits are sized according to local and national codes. Typically, this often requires one or both of the following:
 - AC power supplies typically require at least a 15-A or 20-A AC circuit, 100 to 240 VAC, and a frequency of 50 to 60 Hz.
 - HVAC/HVDC power supplies require the following:
 - HVAC input voltage range of 230 to 277 VAC with a frequency of 50 to 60 Hz
 - HVDC input voltage range of -240 to -380 VDC
 - DC power supplies require the following:
 - DC input voltage range of -48 to -60 VDC nominal (self-ranging, -40 to -60 VDC)
 - DC line input current (steady state) of 23 A peak at -48 VDC



Caution To prevent loss of input power, ensure the total maximum loads on the circuits supplying power to the switch are within the current ratings for the wiring and breakers.



Note For AC input application, please refer to the statement below:



Warning **Statement 1005**—Circuit Breaker

This product relies on the building's installation for short-circuit (overcurrent) protection. Ensure that the protective devices is rated not greater than 20A (North America), 16A (Europe), and 13A (UK).



Note For DC input application, please refer to the statement below:



Warning **Statement 1005**—Circuit Breaker

This product relies on the building's installation for short-circuit (overcurrent) protection. Ensure that the protective devices is rated not greater than 40A for the regular DC power supplies (rated 48-60VDC) and 10A for the HVDC power supplies.

Unpacking and Inspecting the Switch

Before you install the switch, be sure to unpack and inspect the switch for damage or missing components. If anything is missing or damaged, contact your customer service representative immediately.



Tip Keep the shipping container in case the chassis requires shipping at a later time.

Before you begin

Before you unpack the switch and before you handle any switch components, be sure that you are wearing a grounded electrostatic discharge (ESD) strap. To ground the strap, attach it directly to an earth ground or to a grounded rack or grounded chassis (there must be a metal-to-metal connection to the earth ground).

-
- Step 1** Compare the shipment to the equipment list provided by your customer service representative and verify that you have received all items, including the following:
- Accessory Kit
- Step 2** Check for damage and report any discrepancies or damage to your customer service representative. Have the following information ready:
- Invoice number of shipper (see packing slip)
 - Model and serial number of the damaged unit
 - Description of damage
 - Effect of damage on the installation
- Step 3** Check to be sure that each of the power supply and the fan tray modules have the expected direction of airflow as follows:
- Port-side intake airflow modules
 - Burgundy (fan modules and AC power supplies)
 - Green (DC power supplies)

- Port-side exhaust airflow modules
 - Blue (fan modules and AC power supplies)
 - Gray (DC power supplies)
- Dual-direction airflow power-supply modules
 - White (see the color of the fan modules to determine the airflow direction used)

Note All power supplies and fan modules must have the same direction of airflow.

Installing the Switch Using the NXK-ACC-KIT-1RU Rack-Mount Kit

To install the switch, you must attach front and rear mounting brackets to the switch, install slider rails on the rear of the rack, slide the switch onto the slider rails, and secure the switch to the front of the rack. Typically, the front of the rack is the side easiest to access for maintenance.



Note You must supply the eight 10-32 or 12-24 screws required to mount the slider rails and switch to the rack.

Before you begin

- You have inspected the switch shipment to ensure that you have everything ordered.
- Make sure that the switch rack-mount kit includes the following parts:
 - Front rack-mount brackets (2)
 - Rear rack-mount brackets (2)
 - Slider rails (2)
 - M4 x 0.7 x 8-mm Phillips countersink screws (12)
- The rack is installed and secured to its location.

Step 1

Install two front rack-mount brackets and the two rear rack-mount brackets to the switch as follows:

a) Determine which end of the chassis is to be located in the cold aisle as follows:

- If the switch has port-side intake modules (fan modules with burgundy coloring), position the switch so that its ports will be in the cold aisle.
- If the switch has port-side exhaust modules (fan modules with blue coloring), position the switch so that its fan and power supply modules will be in the cold aisle.

Note If the power supply modules have white coloring, look at the fan modules to determine the airflow direction for the switch.

- b) Position the front rack-mount bracket and the rear rack-mount bracket so that its screw holes are aligned to the screw holes on the side of the chassis.

Note You can align the holes in the rack-mount bracket to the holes on the side of the chassis (see the two ways to mount these brackets on a typical chassis, in following figure). The holes that you use depend on the requirements of your rack and the amount of clearance required for interface cables (3 inches [7.6 mm] minimum) and module handles (1 inch [2.5 mm] minimum).

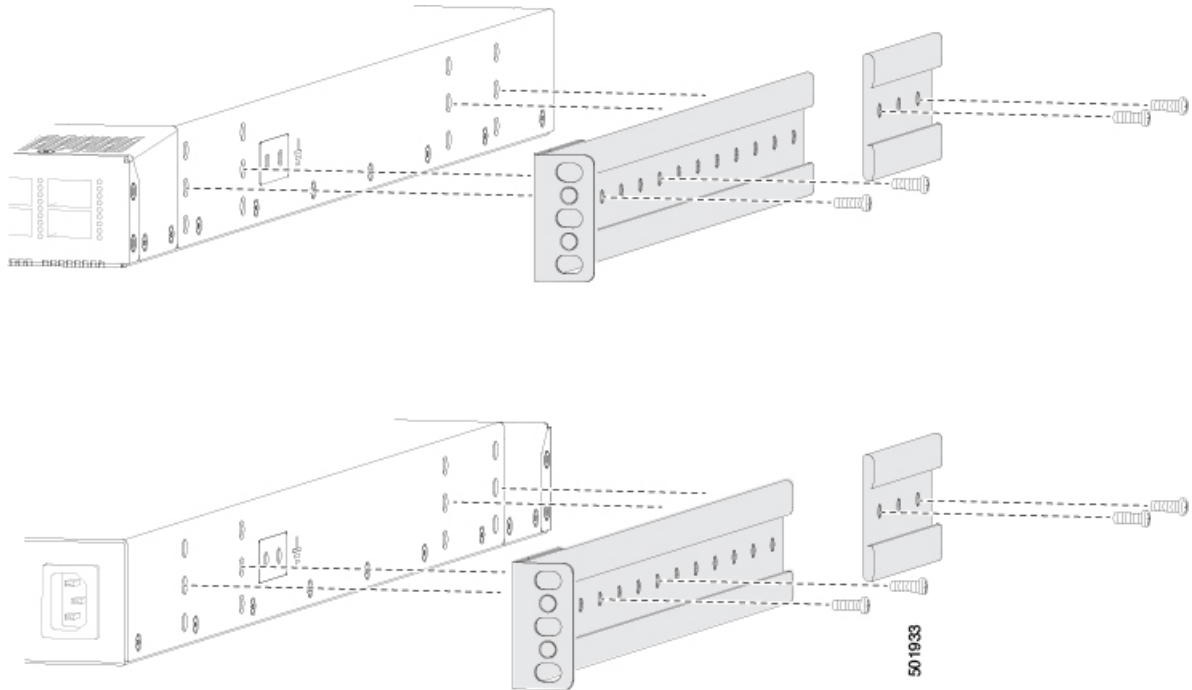

- c) Secure the front-mount bracket and the back-mount bracket to the chassis using four M4 screws and tighten each screw to 12 in-lb (1.36 N·m) of torque.
- d) Repeat Step 1 for the other front rack-mount bracket and the other back-mount bracket on the other side of the switch and be sure to position that bracket the same distance from the front of the switch.

Note Depending on the chassis depth, the back rack-mount bracket may not fit. In that case the back rack-mount bracket is not needed.

Step 2 If you are not installing the chassis into a grounded rack, you must attach a customer-supplied grounding wire to the chassis as explained in the [Grounding the Chassis, on page 24](#) section. If you are installing the chassis into a grounded rack, you can skip this step.

Step 3 Install the slider rails on the rack or cabinet as follows:

- a) Determine which two posts of the rack or cabinet you should use for the slider rails. Of the four vertical posts in the rack or cabinet, two will be used for the front mount brackets attached to the easiest accessed end of the chassis, and the other two posts will have the slider rails.
- b) Position a slider rail at the desired level on the back side of the rack and use 12-24 screws or 10-32 screws, depending on the rack thread type, to attach the rails to the rack (see the following figure). Tighten 12-24 screws to 30 in-lb (3.39 N·m) of torque and tighten 10-32 screws to 20 in-lb (2.26 N·m) of torque.

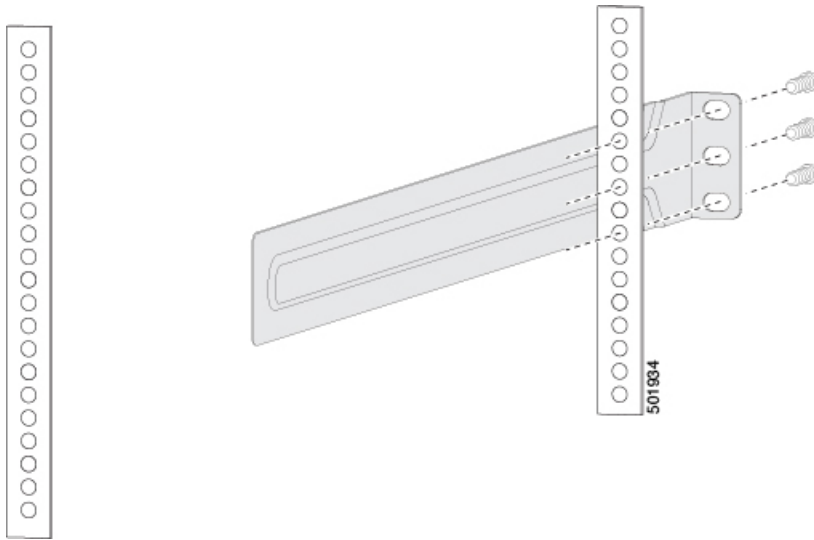

- c) Repeat Step 3 to attach the other slider rail to the other side of the rack.

To make sure that the slider rails are at the same level, you should use a level tool, tape measure, or carefully count the screw holes in the vertical mounting rails.

Step 4 Insert the switch into the rack and attach it as follows:

- a) Holding the switch with both hands, position the two rear rack-mount brackets on the switch between the rack or cabinet posts that do not have slider rails attached to them (see the following figure).

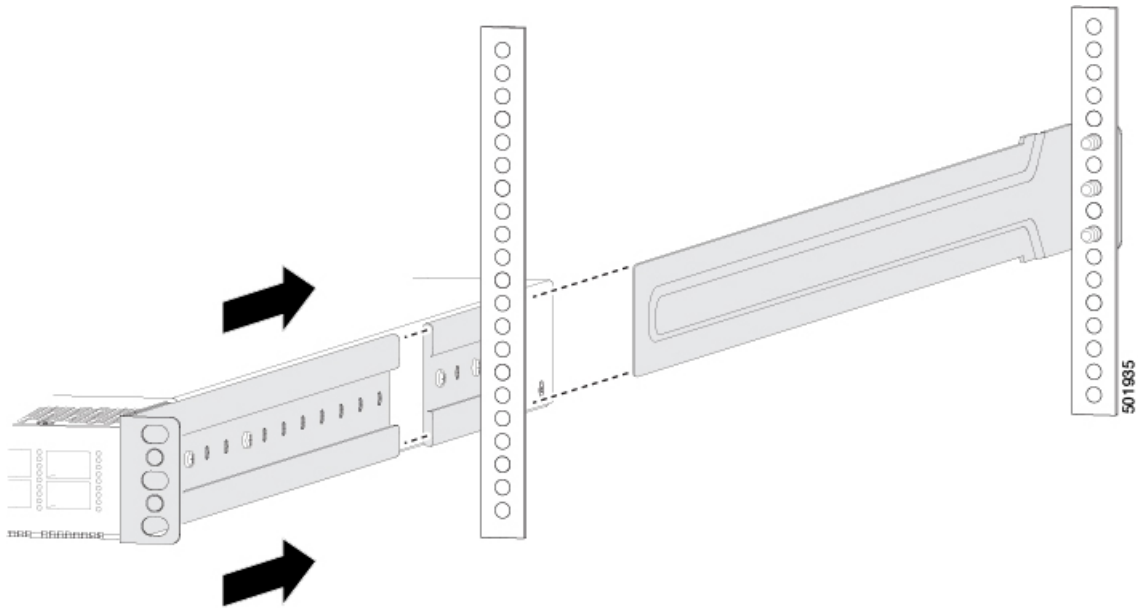

- b) Align the two rear rack-mount guides on either side of the switch with the slider rails installed in the rack. Slide the rack-mount guides onto the slider rails, and then gently slide the switch all the way into the rack until the front rack-mount brackets come in contact with two rack or cabinet posts.

Note If you attached a grounding cable to the chassis, you will need to bend one of the rack-mount rails slightly to allow the grounding lug to go behind the rail.

- c) Holding the chassis level, insert screws (12-24 or 10-32, depending on the rack type) in each of the two front rack-mount brackets (using a total of six screws) and into the cage nuts or threaded holes in the vertical rack-mounting rails (see the following figure).

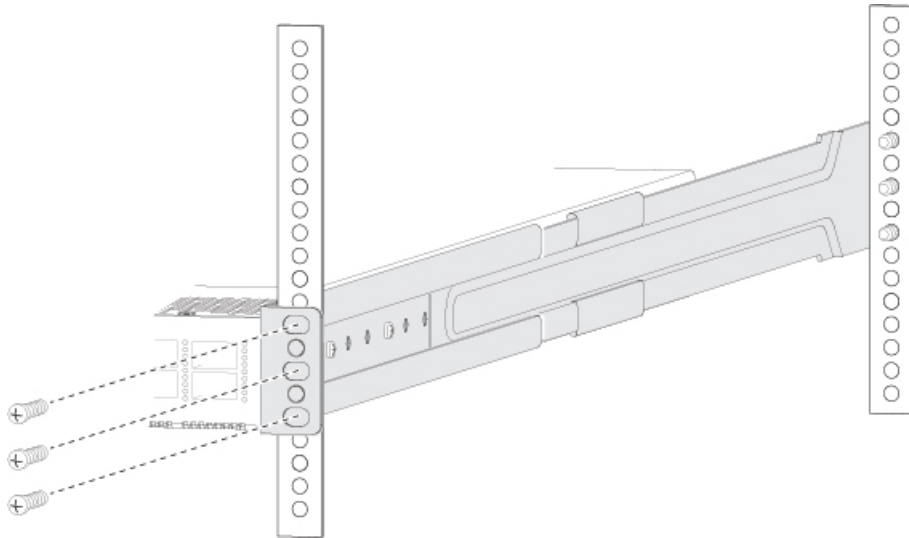

- d) Tighten the 10-32 screws to 20 in-lb (2.26 N·m) or tighten the 12-24 screws to 30 in-lb (3.39 N·m).

Step 5

If you attached a grounding wire to the chassis grounding pad, connect the other end of the wire to the facility ground.

Installing the Switch Using the N3K-C3064-ACC-KIT Rack-Mount Kit

To install the switch, you must attach front and rear mounting brackets to the switch, install slider rails on the rear of the rack, slide the switch onto the slider rails, and secure the switch to the front of the rack. Typically, the front of the rack is the side easiest to access for maintenance.



Note You must supply the eight 10-32 or 12-24 screws required to mount the slider rails and switch to the rack.

Before you begin

- You have inspected the switch shipment to ensure that you have everything ordered.
- Make sure that the switch rack-mount kit includes the following parts:
 - Front rack-mount brackets (2)
 - Rear rack-mount brackets (2)
 - Slider rails (2)
 - M4 x 0.7 x 8-mm Phillips countersink screws (12)

- The rack is installed and secured to its location.

Step 1

Install two front-mount brackets to the switch as follows:

a) Determine which end of the chassis is to be located in the cold aisle as follows:

- If the switch has port-side intake modules (fan modules with burgundy coloring), position the switch so that its ports will be in the cold aisle.
- If the switch has port-side exhaust modules (fan modules with blue coloring), position the switch so that its fan and power supply modules will be in the cold aisle.

Note If the power supply modules have white coloring, look at the fan modules to determine the airflow direction for the switch.

b) Position a front-mount bracket so that four of its screw holes are aligned to the screw holes on the side of the chassis.

Note You can align any four of the holes in the front rack-mount bracket to four of the six screw holes on the side of the chassis (see the two ways to mount these brackets on a typical chassis, in following figure). The holes that you use depend on the requirements of your rack and the amount of clearance required for interface cables (3 inches [7.6 mm] minimum) and module handles (1 inch [2.5 mm] minimum).

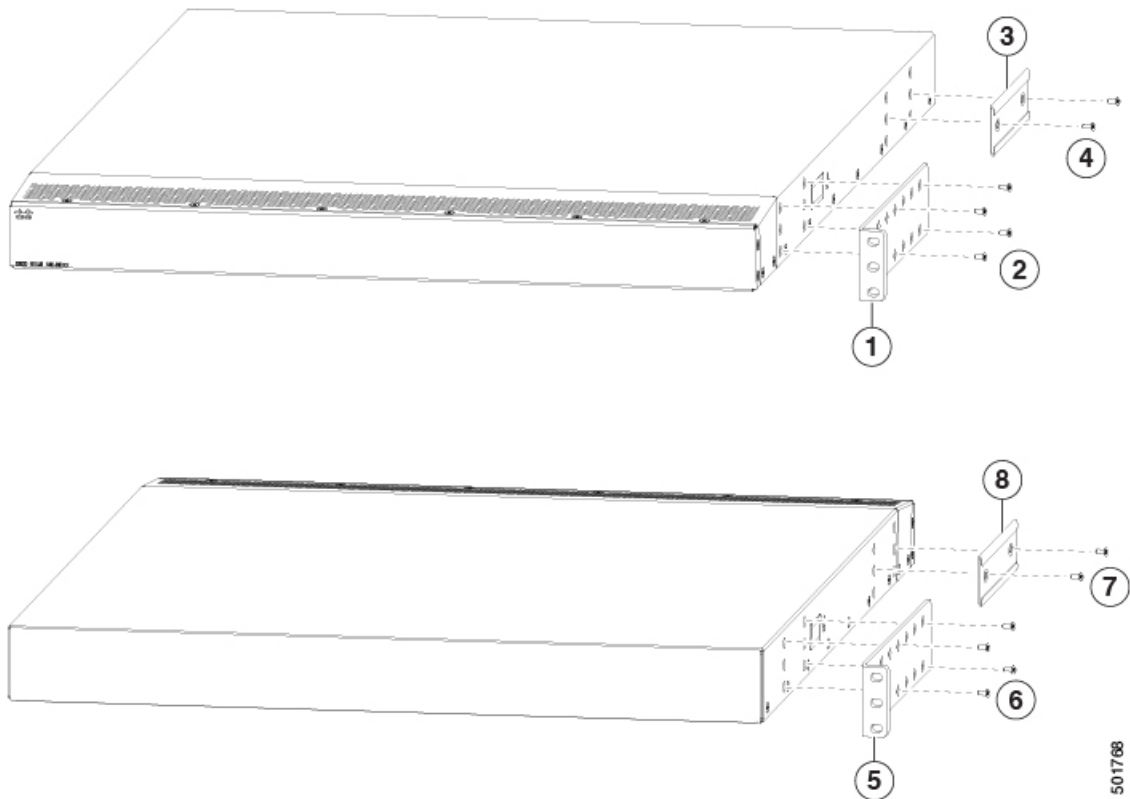

1 Front rack-mount bracket aligned to the port end of the chassis	5 Front rack-mount bracket aligned to the module end of the chassis
---	---

2	Four M4 screws used to attach the bracket to the chassis	6	Four M4 screws used to attach the bracket to the chassis
3	Rear rack-mount guide aligned to the module end of the chassis	7	Two M4 screws used to attach the bracket to the chassis
4	Two M4 screws used to attach the bracket to the chassis	8	Rear rack-mount guide aligned to the port end of the chassis

- c) Secure the front-mount bracket to the chassis using four M4 screws and tighten each screw to 12 in-lb (1.36 N·m) of torque.
- d) Repeat Step 1 for the other front rack-mount bracket on the other side of the switch and be sure to position that bracket the same distance from the front of the switch.

Step 2 Install the two rear rack-mount brackets on the chassis as follows:

- a) Align the two screw holes on a rear rack-mount bracket to the middle two screw holes in the remaining six screw holes on a side of the chassis. If you are aligning the guide to holes that are near the port connections end of the chassis, see Callout 3 in the previous figure. Otherwise, see Callout 7 in the previous figure.
- b) Attach the guide to the chassis using two M4 screws (see Callout 4 or 8 in the previous figure). Tighten the screws to 12 in-lb (1.36 N·m) of torque.
- c) Repeat Step 2 for the other rear rack-mount bracket on the other side of the switch.

Step 3 If you are not installing the chassis into a grounded rack, you must attach a customer-supplied grounding wire to the chassis as explained in the [Grounding the Chassis, on page 24](#) section. If you are installing the chassis into a grounded rack, you can skip this step.

Step 4 Install the slider rails on the rack or cabinet as follows:

- a) Determine which two posts of the rack or cabinet you should use for the slider rails. Of the four vertical posts in the rack or cabinet, two will be used for the front mount brackets attached to the easiest accessed end of the chassis, and the other two posts will have the slider rails.
- b) Position a slider rail at the desired level on the back side of the rack and use two 12-24 screws or two 10-32 screws, depending on the rack thread type, to attach the rails to the rack (see the following figure). Tighten 12-24 screws to 30 in-lb (3.39 N·m) of torque and tighten 10-32 screws to 20 in-lb (2.26 N·m) of torque.

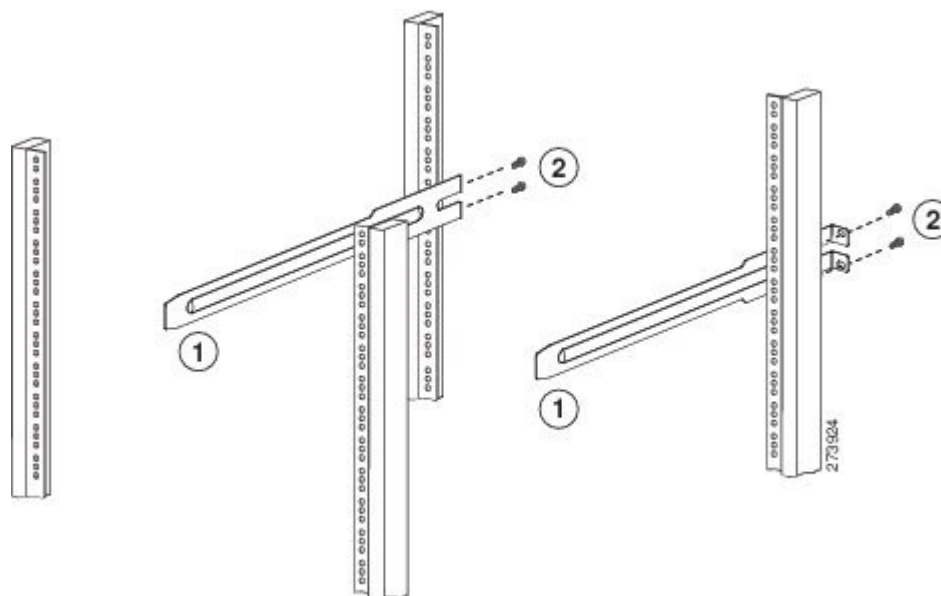

1	Slider rail with screw holes aligned to screw holes in rack	2	Two customer-supplied 12-24 or 10-32 screws used to attach each slider rail to the rack
---	---	---	---

- c) Repeat Step 3 to attach the other slider rail to the other side of the rack.

To make sure that the slider rails are at the same level, you should use a level tool, tape measure, or carefully count the screw holes in the vertical mounting rails.

Step 5 Insert the switch into the rack and attach it as follows:

- a) Holding the switch with both hands, position the two rear rack-mount brackets on the switch between the rack or cabinet posts that do not have slider rails attached to them (see the following figure).

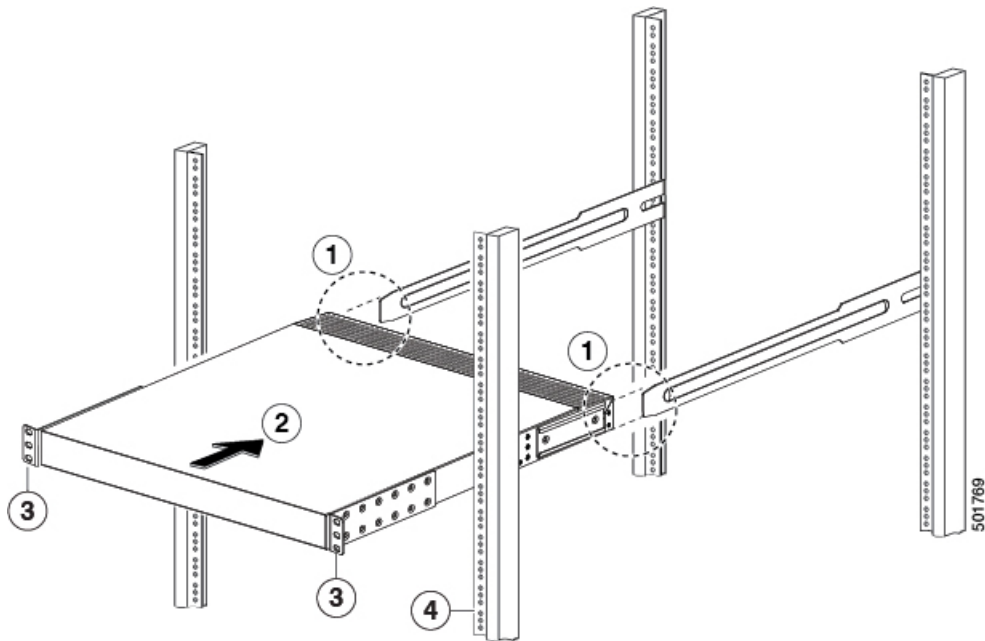

1	Align the two rear rack-mount bracket guides with the slider rails installed in the rack.	3	Front-mount brackets.
2	Slide the rack-mount guides onto the slider rails until the front rack-mount brackets come in contact with the front rack-mount rails.	4	Mounting rails on rack or cabinet posts.

- b) Align the two rear rack-mount guides on either side of the switch with the slider rails installed in the rack. Slide the rack-mount guides onto the slider rails, and then gently slide the switch all the way into the rack until the front rack-mount brackets come in contact with two rack or cabinet posts.

Note If you attached a grounding cable to the chassis, you will need to bend one of the rack-mount rails slightly to allow the grounding lug to go behind the rail.

- c) Holding the chassis level, insert two screws (12-24 or 10-32, depending on the rack type) in each of the two front rack-mount brackets (using a total of four screws) and into the cage nuts or threaded holes in the vertical rack-mounting rails (see the following figure).

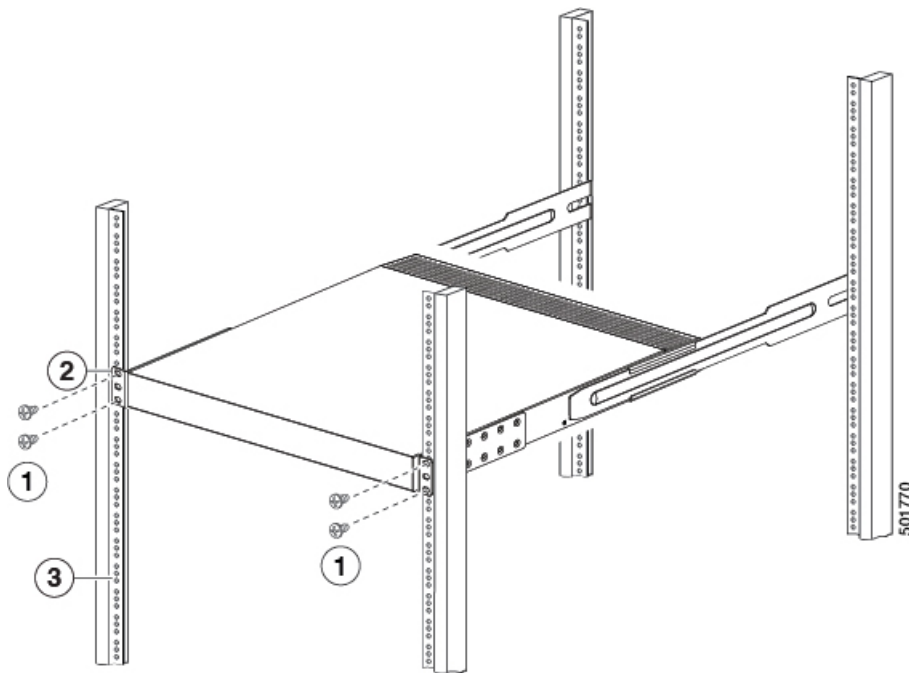

1	Fasten the chassis to the front of the rack with two 12-24 or 10-32 screws on each side.	3	Mounting rails on rack or cabinet posts.
2	Front-mount bracket.		

d) Tighten the 10-32 screws to 20 in-lb (2.26 N·m) or tighten the 12-24 screws to 30 in-lb (3.39 N·m).

Step 6 If you attached a grounding wire to the chassis grounding pad, connect the other end of the wire to the facility ground.

Grounding the Chassis

The switch chassis is automatically grounded when you properly install the switch in a grounded rack with metal-to-metal connections between the switch and rack.

You can also ground the chassis, which is required if the rack is not grounded, by attaching a customer-supplied grounding cable. Attach the cable to the chassis grounding pad and the facility ground.



Warning Statement 1024—Ground Conductor

This equipment must be grounded. To reduce the risk of electric shock, never defeat the ground conductor or operate the equipment in the absence of a suitably installed ground conductor. Contact the appropriate electrical inspection authority or an electrician if you are uncertain that suitable grounding is available.



Warning Statement 1046—Installing or Replacing the Unit

To reduce risk of electric shock, when installing or replacing the unit, the ground connection must always be made first and disconnected last.

Before you begin

Before you can ground the chassis, you must have a connection to the earth ground for the data center building.

Step 1 Use a wire-stripping tool to remove approximately 0.75 inch (19 mm) of the covering from the end of the grounding wire. We recommend 6-AWG wire for the U.S. installations.

Step 2 Insert the stripped end of the grounding wire into the open end of the grounding lug. Use a crimping tool to crimp the lug to the wire, see the following figure. Verify that the ground wire is securely attached to the grounding lug by attempting to pull the wire out of the crimped lug.

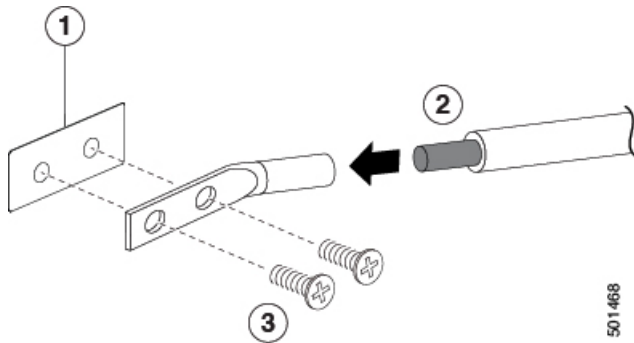

1	Chassis grounding pad	3	2 M4 screws are used to secure the grounding lug to the chassis
2	Grounding cable, with 0.75 in. (19 mm) of insulation that is stripped from one end, which is inserted into the grounding lug and crimped in place		

Step 3 Secure the grounding lug to the chassis grounding pad with two M4 screws, see the previous figure. Tighten the screws to 11 to 15 in-lb (1.24 to 1.69 N·m) of torque.

Step 4 Prepare the other end of the grounding wire and connect it to the facility ground.

Starting the Switch

You start the switch by connecting it to its dedicated power source. If you need $n+1$ redundancy, you must connect each of the power supplies to one or two power sources. If you need $n+n$ redundancy, you must connect each power supply in a switch to a different power source.

Before you begin

- The switch must be installed and secured to a rack or cabinet.
- The switch must be adequately grounded.
- The rack must be close enough to the dedicated power source so that you can connect the switch to the power source by using a designated power cables.
- You have the designated power cables for the power supplies that you are connecting to the dedicated power sources.



Note Depending on the outlet receptacle on your AC power distribution unit, you might need an optional jumper power cord to connect the switch to your outlet receptacle.

- The switch is not connected to the network (this includes any management or interface connections).
- The fan and power supply modules are fully secured in their chassis slots.

Step 1 For each AC power supply, do the following:

- a) Using the recommended AC power cable for your country or region, connect one end to the AC power supply.
- b) Connect the other end of the power cable to the AC power source.

Step 2 For each HVAC/HVDC power supply, connect it to a power source as follows:

- a) Using the recommended high voltage power cable for your country or region, connect the Anderson Power Saf-D-Grid connector on the power cable to the power receptacle on the power supply. Make sure that the connector clicks when fully pushed into the receptacle.
- b) Connect the other end of the power cable to a power source.
 - When connecting to an HVAC power source, insert the C14 or LS-25 plug in a receptacle for the HVAC power source.
 - When connecting to an HVDC power source, do the following:
 1. Verify that the power is turned off at a circuit breaker for the power source terminals.
 2. Remove the nuts from each of the terminal posts for the power supply.
 3. Place the power cable negative-wire terminal ring on the negative terminal for the power source and secure them with a terminal nut.
 4. Place the power cable positive-wire terminal ring on the positive terminal for the power source and secure them with a terminal nut.

5. Place the power cable ground-wire terminal ring on the ground terminal for the power source and secure them with a terminal nut.
6. If there is a safety cover for the power source terminals, place and secure it over the terminals to avoid an electrical shock hazard.
7. Turn on the power at the power source circuit breaker.

Step 3 For each DC power supply, do the following:

- a) Turn off the circuit breaker for the power source to avoid an electrical shock hazard.
- b) Verify that the power cable wires from the power source are connected to a connector block.
- c) Insert the connector block into the receptacle on the power supply. Make sure that the connector block clicks when fully inserted in the receptacle and does not pull out.
- d) If there is a safety cover for the terminals, place and secure it over the terminals to avoid an electrical shock hazard.
- e) Turn on the power at the circuit breaker for the DC power source.

Step 4 Verify that the power supply  LED is on and green.

Step 5 Listen for the fans; they should begin operating when the power supply is powered.

Step 6 After the switch boots, verify that the following LEDs are lit:

- On the fan modules, the Status (STA or STS) LED is green.
If a fan module Status LED is not green, try reinstalling the fan module.
- After initialization, the switch chassis Status (labeled as STA or STS) LED is green.

Step 7 Verify that the system software has booted and the switch has initialized without error messages.

A setup utility automatically launches the first time that you access the switch and guides you through the basic configuration. For instructions on how to configure the switch and check module connectivity, see the appropriate Cisco Nexus 9000 Series configuration guide.



CHAPTER 4

Connecting the Switch to the Network

- [Overview of Network Connections, on page 29](#)
- [Connecting a Console to the Switch, on page 29](#)
- [Creating the Initial Switch Configuration, on page 31](#)
- [Setting Up the Management Interface, on page 32](#)
- [Connecting Interface Ports to Other Devices, on page 33](#)
- [Uplink Connections, on page 33](#)
- [Downlink Connections, on page 33](#)

Overview of Network Connections

After you install the switch in a rack and power it up, you are ready to make the following network connections:

- **Console connection**—This is a direct local management connection that you use to initially configure the switch. You must make this connection first to initially configure the switch and determine its IP address, which is needed for the other connections.
- **Management connection**—After you complete the initial configuration using a console, you can make this connection to manage all future switch configurations.
- **Uplink and downlink interface connections**—These are connections to hosts and servers in the network.

Each of these connection types is explained in one of the sections that follow.



Note

When running cables in overhead or subfloor cable trays, we strongly recommend that you locate power cables and other potential noise sources as far away as practical from network cabling that terminates on Cisco equipment. In situations where long parallel cable runs cannot be separated by at least 3.3 feet (1 meter), we recommend that you shield any potential noise sources by housing them in a grounded metallic conduit.

Connecting a Console to the Switch

Before you create a network management connection for the switch or connect the switch to the network, you must create a local management connection through a console terminal. And then configure an IP address for

the switch. You can use the console to perform the following functions, each of which can be performed through the management interface after you make that connection:

- Configure the switch using the command-line interface (CLI).
- Monitor network statistics and errors.
- Configure Simple Network Management Protocol (SNMP) agent parameters.
- Download software updates.

You make this local management connection between the asynchronous serial port on a supervisor module and a console device capable of asynchronous transmission. Typically, you can use a computer terminal as the console device. On the supervisor modules, you use the console serial port.



Note Before you can connect the console port to a computer terminal, make sure that the computer terminal supports VT100 terminal emulation. The terminal emulation software makes communication between the switch and computer possible during setup and configuration.

Before you begin

- The switch must be fully installed in its rack, which is connected to a power source, and grounded.
- The necessary cabling for the console, management, and network connections must be available.
 - An RJ-45 rollover cable is provided in the switch accessory kit.
 - Network cabling is routed to the location of the installed switch.

Step 1 Configure the console device to match the following default port characteristics:

- 9600 baud
- 8 data bits
- 1 stop bit
- No parity

Step 2 Connect an RJ-45 rollover cable to the console port on the switch.

You can find this cable in the accessory kit.

Step 3 Route the RJ-45 rollover cable to the console or modem.

Step 4 Connect the other end of the RJ-45 rollover cable to the console or to a modem.

What to do next

You are ready to create the initial switch configuration (see [Creating the Initial Switch Configuration, on page 31](#)).

Creating the Initial Switch Configuration

You assign an IP address to the switch management interface so that you can then connect the switch to the network.

When you initially power up the switch, it boots up and asks you a series of questions to configure the switch. To connect the switch to the network, you can use the default choices for each configuration except the IP address, which you must provide. You can perform the other configurations later as described in the *Cisco Nexus 9000 Series NX-OS Fundamentals Configuration Guide*.



Note Know the unique name that is needed to identify the switch among the devices in the network.

Before you begin

- A console device must be connected with the switch.
- The switch must be connected to a power source.
- Determine the IP address and the netmask that is needed for the Management (Mgmt0) interface.

Step 1 Power up the switch by connecting each installed power supply to an AC circuit.

If you are using the combined or power-supply ($n+1$) power mode, connect all the power supplies to the same AC circuit. If you are using the input-source ($n+n$) power mode, connect half of the power supplies to one AC circuit. And connect the other half of the power supplies to another AC circuit.

The Input and Output LEDs on each power supply light up (green) when the power supply units are sending power to the switch, and the software asks you to specify a password to use with the switch.

Step 2 Enter a new password to use for this switch.

The software checks the security strength of your password and rejects your password if it is not considered to be a strong password. To increase the security strength of your password, make sure that it adheres to the following guidelines:

- At least eight characters
- Minimizes or avoids the use of consecutive characters (such as "abcd").
- Minimizes or avoids repeating characters (such as "aaabbb").
- Does not contain recognizable words from the dictionary.
- Does not contain proper names.
- Contains both uppercase and lowercase characters
- Contains numbers and letters

Examples of strong passwords include the following:

- If2CoM18
- 2004AsdfLkj30

- Cb1955S21

Note Clear text passwords cannot include the dollar sign (\$) special character.

Tip If a password is trivial (such as a short, easy-to-decipher password), the software will reject your password configuration. Be sure to configure a strong password as explained in this step. Passwords are case-sensitive.

If you enter a strong password, the software asks you to confirm the password.

Step 3 Enter the same password again.

If you enter the same password, the software accepts the password and begins asking a series of configuration questions.

Step 4 Until you are asked for an IP address, you can enter the default configuration for each question.

Repeat this step for each question until you are asked for the Mgmt0 IPv4 address.

Step 5 Enter the IP address for the management interface.

The software asks for the Mgmt0 IPv4 netmask.

Step 6 Enter a network mask for the management interface.

The software asks if you need to edit the configuration.

Step 7 Enter **no** not to edit the configuration.

The software asks if you need to save the configuration.

Step 8 Enter **yes** to save the configuration.

What to do next

You can now set up the management interface for each supervisor module on the switch.

Setting Up the Management Interface

The RJ-45 and/or SFP management ports provide out-of-band management, which enables you to use the command-line interface (CLI) to manage the switch by its IP address. You can use one of these ports depending on the cable and connectors that you are using to connect the management interface to the network.

Before you begin

- The switch must be powered on.
- The switch must be initially configured using a console.

Step 1 Connect the management cable into the management port on the switch. For shorter connections, you can use a cable with RJ-45 connectors. For longer connections, you can use an optical cable with SFP transceivers (LH or SX type).

Note Use only one of these management ports—the switch does not support the use of both management ports.

Step 2 Connect the other end of the cable to a 10/100/1000 or SFP port on a network device.

Connecting Interface Ports to Other Devices

After you perform the initial configuration for the switch and create a management connection, you are ready to connect the interface ports on the switch to other devices. Depending on the types of interface ports on the switch, you will need to use interface cables with QSFP28, QSFP+, SFP+, SFP transceivers, or RJ-45 connectors to connect the switch to other devices.



Note If you need to use SFP+ or SFP transceivers in a QSFP+ or QSFP28 uplink port, install a QSFP-to-SFP adapter, such as the CVR-QSFP-SFP10G adapter, in the QSFP port and then install the SFP+ or SFP transceiver. The switch automatically sets the port speed to the speed of the installed transceiver.

If the transceivers that you are using can be separated from their optical cables, install the transceivers without their cables before inserting the cables into the transceivers. This helps to prolong the life of both the transceiver and cables. When removing transceivers from the switch, it is best to remove the optical cable first and then remove the transceiver.

To determine which transceivers, adapters, and cables are supported by this switch, see the [Cisco Transceiver Modules Compatibility](#) Information document.

Uplink Connections

For a list of transceivers and cables used by this switch for uplink connections, see <http://www.cisco.com/c/en/us/support/interfaces-modules/transceiver-modules/products-device-support-tables-list.html>.

The six 40- and 100-Gigabit Ethernet QSFP28 uplink ports support 4 x 10-Gigabit and 4 x 25-Gigabit breakout cables and 1- and 10-Gigabit Ethernet with QSFP-to-SFP adapters.

The six 40- and 100-Gigabit Ethernet QSFP28 uplink ports support 10-, 25-, 40-, 50-, and 100-Gigabit connectivity. You can use 4x10-Gigabit and 4x25-Gigabit breakout cables with these ports.



Warning **Statement 1051**—Laser Radiation

Invisible laser radiation may be emitted from disconnected fibers or connectors. Do not stare into beams or view directly with optical instruments.

Downlink Connections

The Cisco Nexus 93108TC-EX switch has 48 downlink ports that connect to servers. Each of these ports supports 100-Megabit, 1-Gigabit, 10-Gigabit speeds over 10GBASE-T cables.

For a listing of the transceivers and cables that the optical downlink ports support, see <http://www.cisco.com/c/en/us/support/interfaces-modules/transceiver-modules/products-device-support-tables-list.html>

For the 10GBASE-T cables, you use RJ-45 connectors on cables that conform to the specifications in the following table.

Table 1: Supported 10GBASE-T Cables

Cable Type	Supported Length
Category 6	180 feet (55 m)
Category 6a	328 feet (100 m)
Category 7	328 feet (100 m)
Category 7a	328 feet (100 m)



CHAPTER 5

Replacing Modules

- [Replacing a Fan Module, on page 35](#)
- [Replacing a Power Supply Module, on page 36](#)

Replacing a Fan Module

You can replace a fan module while the switch is operating so long as you perform the replacement within one minute. If you cannot perform the replacement within one minute, leave the original fan module in the chassis to maintain the designed airflow until you have the replacement fan module on hand and can perform the replacement.



Caution

If you are replacing a module during operations, be sure that the replacement fan module has the correct direction of airflow, which means that it has the same airflow direction as the other modules in the chassis. Also, be sure that the airflow direction takes in air from a cold aisle and exhausts to a hot aisle. Otherwise, the switch can overheat and shutdown.

If you are changing the airflow direction of all the modules in the chassis, you must shutdown the switch before replacing all the fan and power supply modules with modules using the other airflow direction. During operations, all of the modules must have the same direction of airflow.

Removing a Fan Module



Warning

Statement 263—Fan Warning

The fans might still be turning when you remove the fan assembly from the chassis. Keep fingers, screwdrivers, and other objects away from the openings in the fan assembly's housing.

- Step 1** On the fan module that you are removing, press the two sides of the fan module handle next to where it connects to the fan module and pull on the handles enough to unseat it from its connectors.
- Step 2** Holding the handle, pull the module out of the chassis.

Caution Do not touch the electrical connectors on the back side of the module and prevent anything else from coming into contact with and damaging the connectors.

Installing a Fan Module

Before you begin

- A fan slot must be open and ready for the new fan module to be installed.
 - You must have a new fan module on hand and ready to install within one minute of removing the original fan module if the switch is operating.
 - The new fan module must have the same airflow direction as the other fan and power supply modules installed in the switch. All of these modules must have either burgundy coloring (port-side intake airflow) or they must all have blue coloring (port-side exhaust airflow).
-

- Step 1** Holding the fan module by its handle, align the back of the fan module (the side with the electrical connectors) to the open fan slot in the chassis.
- Step 2** Slide the fan module into the slot until it clicks in place.
- Step 3** Verify that the Status (STS) LED turns on and becomes green.
-

Replacing a Power Supply Module

The switch requires two power supplies for redundancy. With one power supply providing the necessary power for operations, you can replace the other power supply during operations so long as the new power supply has the same airflow direction as the other modules in the chassis.

You can replace a power supply with another supported power supply that has the same power source type and the same wattage rating as the other installed power supply. Additionally, the airflow direction of the power supply must match or conform to the airflow direction of the installed fan modules. For the airflow direction used by the switch, see the coloring of the fan modules.



Removing an AC Power Supply

To remove an AC power supply, you must first disconnect the power cable and then remove the module from the chassis.

Before you begin

- To replace a power supply during operations, you must have a functioning power supply providing power to the switch while you replace the other power supply. If there is only one power supply installed in the switch and you need to replace it, install the new power supply in the open slot and power it up before removing the original power supply.

- Ensure that the chassis is grounded. For grounding instructions, see [Grounding the Chassis, on page 24](#).

-
- Step 1** Pull the power cord out from the power receptacle on the power supply to be removed and verify that the  LED turns off.
- Note** The  LED might be on and amber colored to indicate that the input power has been disconnected.
- Note** If you need to remove an Anderson's Saf-D-Grid power cable connector from a high-voltage power supply, press the tab at the top of the connector and pull the connector out of the power supply.
- Step 2** Remove the power supply from the chassis by pushing and holding its thumb latch to the left and pulling the power supply part way out of the chassis.
- Step 3** Place your other hand under the power supply to support it while you slide it out of the chassis.
Either place the power supply on an antistatic surface or pack it in its packing materials.
- Step 4** If the power supply slot is to remain empty, install a blank power supply filler panel (part number N2200-P-BLNK).
-

What to do next

You are ready to install the replacement power supply.

Removing an HVAC/HVDC Power Supply

You can remove one power supply while the other one provides power to the switch.

To disconnect the power supply from its power cables, you must shut off the power from the power source and then either disconnect a connector for the power cables or release each of three cables from the power supply (requires a standard screw driver).

-
- Step 1** Turn off the circuit breaker for the power feed to the power supply that you are replacing.
Be sure that the LEDs turn off on the power supply that you are removing.
- Step 2** Remove the power cable from the power supply by pressing the tab on the top of the Anderson Power SAF-D-Grid connector and pull the cable and connector out of the power supply.
- Step 3** Grasp the power supply handle while pressing the release latch towards the power supply handle.
- Step 4** Place your other hand under the power supply to support it while you slide it out of the chassis.
- Caution** Do not touch the electrical connectors on the back side of the module and prevent anything else from coming into contact with and damaging the connectors.
-

What to do next

You are ready to install an HVAC/HVDC power supply in the open slot.

Removing a DC Power Supply

You can remove one power supply while the other one provides power to the switch.

To disconnect the power supply from its power cables, you must shut off the power from the power source and then either disconnect a connector for the power cables or release each of three cables from the power supply (requires a standard screw driver).

-
- Step 1** Turn off the circuit breaker for the power feed to the power supply that you are replacing.
Be sure that the LEDs turn off on the power supply that you are removing.
- Step 2** Remove the power cable from the power supply by doing the following:
- To remove an orange power cable connector from a 48-V DC power supply, do the following:
 - a. Push the orange plastic button on the top of the connector block inward toward the power supply.
 - b. Pull the connector block out of the power supply.
 - To remove an Anderson Power Products Saf-D-Grid power cable connector from a high-voltage power supply, press on the tab at the top of the Saf-D-Grid connector and pull the connector out of the power supply.
- Step 3** Grasp the power supply handle while pressing the release latch towards the power supply handle.
- Step 4** Pull the power supply out of the bay.
-

What to do next

You are ready to install a DC power supply in the open slot.

Installing an AC Power Supply

You can replace one power supply while the other one provides power to the switch.

Before you begin

- The power supply that you are installing must be capable of using the same airflow direction as the fan trays installed in the same switch and it must use the same type of power source as the other power supply installed in the same switch (do not mix AC and DC power supplies in the same switch).



Note DC power supplies with green coloring have the same port-side intake airflow direction as the power supplies with red coloring, and DC power supplies with gray coloring have the same port-side exhaust airflow direction as the power supplies with blue coloring. HVAC/HVDC power supplies automatically use the same airflow direction as the installed fan modules. If the power supply that you are replacing has a different color handle than the replacement power supply, verify that it has or will have the same airflow direction as the other modules in the switch.

- An AC power source must be within reach of the power cable that will be used with the replacement power supply. If you are using $n+n$ power redundancy, there must be a separate power source for each power supply installed in the chassis. Otherwise, only one power source is required.
- There must be an earth ground connection to the chassis that you are installing the replacement module. Typically, the chassis is grounded by its metal-to-metal connection with a grounded rack. If you need to ground the chassis, see [Grounding the Chassis, on page 24](#).

Step 1 Holding the replacement power supply with one hand underneath the module and the other hand holding the handle, turn the power supply so that its release latch is on the right side and align the back end of the power supply (the end with the electrical connections) to the open power supply slot before carefully sliding the power supply all the way into the slot until it clicks into place.

Note If the power supply does not fit into the open slot, turn the module over before sliding it carefully into the open slot.

Step 2 Test the installation by trying to pull the power supply out of the slot without using the release latch.

If the power supply does not move out of place, it is secured in the slot. If the power supply moves, carefully press it all the way into the slot until it clicks in place.

Step 3 Attach the power cable to the electrical outlet on the front of the power supply.

Step 4 Make sure that the other end of the power cable is attached to the appropriate power source for the power supply.

Note Depending on the outlet receptacle on your power distribution unit, you might need the optional jumper cable to connect the switch to your outlet receptacle.

Step 5 Verify that the power supply is operational by making sure that the power supply  LED is green. For information on what the power supply LEDs indicate, see [Power Supply LEDs, on page 56](#).

Installing an HVAC/HVDC Power Supply

You can replace one power supply while the other one provides power to the switch.



Note DC power supplies with green coloring have the same port-side intake airflow direction as the power supplies with red coloring, and DC power supplies with gray coloring have the same port-side exhaust airflow direction as the power supplies with blue coloring. HVAC/HVDC power supplies automatically use the same airflow direction as the installed fan modules. If the power supply that you are replacing has a different color handle than the replacement power supply, verify that it has or will have the same airflow direction as the other modules in the switch.

Before you begin

- If you are using DC power for the replacement power supply, the circuit breaker for the power feed to the power supply that you are replacing must be turned off.

- If you are using $n+n$ power redundancy, there must be a separate power source for each power supply installed in the chassis (power sources must be of the same type—do not mix AC and DC power sources for the same switch). Otherwise, only one power source is required.
- There must be an earth ground connection to the chassis that you are installing the replacement module. Typically, the chassis is grounded by its metal-to-metal connection to a grounded rack. If you need to ground this chassis by another means, see [Grounding the Chassis, on page 24](#).

Step 1 Holding the replacement power supply with one hand underneath the module and the other hand holding the handle, turn the power supply so that its release latch is on the right side and align the back end of the power supply (the end with the electrical connections) to the open power supply slot before carefully sliding the power supply all the way into the slot until it clicks into place.

Note If the power supply does not fit into the open slot, turn the module over before sliding it into the open slot.

Step 2 Test the installation by trying to pull the power supply out of the slot without using the release latch. If the power supply does not move out of place, it is secured in the slot. If the power supply moves, carefully press it all the way into the slot until it clicks in place.

Step 3 If the DC power cables and a grounding cable are already connected to an electrical connector block, insert the block into the power receptacle on the power supply. If the electrical cables have not been connected to the electrical connector block, wire them as described in [Wiring a 48 V DC Electrical Connector Block, on page 41](#).

Step 4 Make sure that the other end of the power cable is connected to the appropriate power source for the power supply.

Step 5 If using a DC power source, turn on the circuit breaker for the DC power source connected to the power supply.

Step 6 Verify that the power supply is operational by making sure that the power supply  LED is green. For information on what the power supply LEDs indicate, see [Power Supply LEDs, on page 56](#).

Installing a DC Power Supply

This topic is for installing the 48-V DC power supply into switch chassis. If you need to install a high voltage (HVAC/HVDC) power supply, see [Installing an HVAC/HVDC Power Supply, on page 39](#).

You can replace one power supply while the other one provides power to the switch.

Before you begin

- The circuit breaker for the DC power source for the power supply must be turned off.
- The power supply that you are installing must be capable of using the same airflow direction as the fan trays installed in the same switch
- A DC power source must be within reach of the power cable that will be used with the replacement power supply. If you are using $n+n$ power redundancy, there must be a separate power source for each power supply installed in the chassis (do not mix AC and DC power sources for the same switch). Otherwise, only one power source is required.

- There must be an earth ground connection to the chassis that you are installing the replacement module. Typically, the chassis is grounded by its metal-to-metal connection to a grounded rack. If you need to ground this chassis by another means, see [Grounding the Chassis, on page 24](#).
- We recommend 8-AWG wire for DC installation in the U.S.
- All DC power supplies have reverse polarity protection. When you inadvertently connect the input power (+) to the DC PSU's – terminal and the input power – to the DC PSU's (+) terminal, the PSU will not be damaged and will operate fine after the input power feeds are correctly wired.

Step 1 Holding the replacement power supply with one hand underneath the module and the other hand holding the handle, turn the power supply so that its release latch is on the right side and align the back end of the power supply (the end with the electrical connections) to the open power supply slot before carefully sliding the power supply all the way into the slot until it clicks into place.

Note If the power supply does not fit into the open slot, turn the module over before carefully sliding it into the open slot.

Step 2 If the DC power cables and a grounding cable are already connected to an electrical connector block, insert the block into the power receptacle on the power supply.

If the electrical cables have not been connected to the electrical connector block, wire them as described in [Wiring a 48 V DC Electrical Connector Block, on page 41](#).

Step 3 Turn on the circuit breaker for the DC power source connected to the power supply.

Step 4 Verify that the power supply is operational by making sure that the power supply  LED is green. For information on what the power supply LEDs indicate, see [Power Supply LEDs, on page 56](#).

Wiring a 48 V DC Electrical Connector Block

You must connect the ground, negative, and positive DC power cables to a connector block in order to connect the power cables to a 48 V DC power supply.



Note The recommended wire gauge is 8 AWG. The minimum wire gauge is 10 AWG.



Warning [Statement 342](#)—Before Connecting to System Power Supply

High touch/leakage current – Permanently connected protective earth ground is essential before connecting to system power supply.



Warning [Statement 1024](#)—Ground Conductor

This equipment must be grounded. To reduce the risk of electric shock, never defeat the ground conductor or operate the equipment in the absence of a suitably installed ground conductor. Contact the appropriate electrical inspection authority or an electrician if you are uncertain that suitable grounding is available.

Before you begin

You must turn off the circuit breaker for the DC power cables that you are connecting to prevent electrocution.

- Step 1** Verify that the circuit breaker for the power feed to the replacement power supply is turned off.
- Step 2** Remove the DC power connector block from the power supply by doing the following:
 - a) Push the orange plastic button on the top of the connector block inward toward the power supply.
 - b) Pull the connector block out of the power supply.
- Step 3** Strip 0.6 inches (15 mm) of insulation off the DC wires that you are using.
- Step 4** Orient the connector as shown in the following figure with the orange plastic button on top.

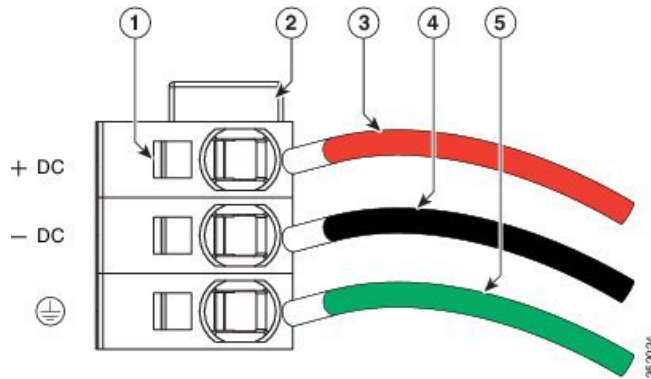

1	Wire retainer lever	4	-48V (-DC) cable
2	Orange plastic button on top of the connector	5	Grounding cable (8 AWG recommended)
3	-48V Return (+DC) cable		

- Step 5** Use a small screwdriver to depress the spring-loaded wire retainer lever on the lower spring-cage wire connector. Insert your green (ground) wire into the aperture and then release the lever.
- Step 6** Use a small screwdriver to depress the spring-loaded wire retainer lever on the middle spring-cage wire connector. Insert your black (DC negative) wire into the aperture and then release the lever.
- Step 7** Use a small screwdriver to depress the spring-loaded wire retainer lever on the upper spring-cage wire connector. Insert your red (DC positive) wire into the aperture and then release the lever.
- Step 8** Insert the connector block back into the power supply. Make sure that your red (DC positive) wire aligns with the power supply label, "+ DC".
- Step 9** Verify that the other ends of the cables are attached to the DC power source and ground. You are then ready to turn on the DC power source.



APPENDIX **A**

Rack Specifications

- [Overview of Racks, on page 43](#)
- [General Requirements for Cabinets and Racks, on page 43](#)
- [Requirements Specific to Standard Open Racks, on page 44](#)
- [Requirements Specific to Perforated Cabinets, on page 44](#)
- [Cable Management Guidelines, on page 44](#)

Overview of Racks

You can install the switch in the following types of cabinets and racks, assuming an external ambient air temperature range of 0 to 104°F (0 to 40°C):

- Standard perforated cabinets
- Solid-walled cabinets with a roof fan tray (bottom to top cooling)
- Standard open racks



Note If you are selecting an enclosed cabinet, we recommend one of the thermally validated types, either standard perforated or solid-walled with a fan tray.



Note We do not recommend that you use racks that have obstructions (such as power strips), because the obstructions could impair access to field-replaceable units (FRUs).

General Requirements for Cabinets and Racks

The cabinet or rack must also meet the following requirements:

- Standard 19-inch (48.3 cm) (two- or four-post EIA cabinet or rack, with mounting rails that conform to English universal hole spacing per section 1 of ANSI/EIA-310-D-1992). For more information, see [Requirements Specific to Perforated Cabinets, on page 44](#).

- The minimum vertical rack space requirement per chassis is:
 - For a one RU (rack unit) switch, 1.75 inches (4.4 cm)
 - For a one and a half RU (rack unit) switch, 2.63 (6.68 cm)
 - For a two RU (rack unit) switch, 3.5 inches (8.8 cm)
 - For a three RU (rack unit) switch, 5.25 inches (13.3 cm)
- The width between the rack-mounting rails must be at least 17.75 inches (45.0 cm) if the rear of the device is not attached to the rack. For four-post EIA racks, this measurement is the distance between the two front rails.

Four-post EIA cabinets (perforated or solid-walled) must meet the following requirements:

- The minimum spacing for the bend radius for fiber-optic cables should have the front-mounting rails of the cabinet offset from the front door by a minimum of 3 inches (7.6 cm).
- The distance between the outside face of the front mounting rail and the outside face of the back mounting rail should be 23.0 to 30.0 inches (58.4 to 76.2 cm) to allow for rear-bracket installation.

Requirements Specific to Standard Open Racks

If you are mounting the chassis in an open rack (no side panels or doors), ensure that the rack meets the following requirements:

- The minimum vertical rack space per chassis must be one rack unit (RU), equal to 1.75 inches (4.4 cm).
- The distance between the chassis air vents and any walls should be 2.5 inches (6.4 cm).

Requirements Specific to Perforated Cabinets

A perforated cabinet has perforations in its front and rear doors and side walls. Perforated cabinets must meet the following requirements:

- The front and rear doors must have at least a 60 percent open area perforation pattern, with at least 15 square inches (96.8 square cm) of open area per rack unit of door height.
- The roof should be perforated with at least a 20 percent open area.
- The cabinet floor should be open or perforated to enhance cooling.

The Cisco R Series rack conforms to these requirements.

Cable Management Guidelines

To help with cable management, you might want to allow additional space in the rack above and below the chassis to make it easier to route all of the fiber optic or copper cables through the rack.



APPENDIX **B**

System Specifications

- [Environmental Specifications, on page 45](#)
- [Switch Dimensions, on page 45](#)
- [Switch and Module Weights and Quantities, on page 46](#)
- [Transceiver and Cable Specifications, on page 46](#)
- [Switch Power Input Requirements, on page 46](#)
- [Power Specifications, on page 47](#)
- [Power Cable Specifications, on page 50](#)
- [Regulatory Standards Compliance Specifications, on page 52](#)

Environmental Specifications

Environment		Specification
Temperature	Ambient operating temperature	32 to 104°F (0 to 40°C)
	Ambient nonoperating	−40 to 158°F (−40 to 70°C)
Relative humidity	Nonoperating	5 to 85%
Altitude	Operating	0 to 13,123 feet (0 to 4,000 meters)

Switch Dimensions

Switch	Width	Depth	Height
Cisco Nexus 93108TC-EX	17.3 inches (43.9 cm)	22.5 inches (57.1 cm)	1.72 inches (4.4 cm) (1 RU)

Switch and Module Weights and Quantities

Component	Weight per Unit	Quantity
Cisco Nexus 93108TC-EX Chassis (N9K-C93108TC-EX)	17.7 lb (8.0 kg)	1
Fan Module	—	4
– Port-side exhaust (blue) (NXA-FAN-30CFM-F)	0.26 lb (0.12 kg)	
– Port-side intake (burgundy) (NXA-FAN-30CFM-B)		
Power Supply module	—	2 (1 for operations and 1 for redundancy)
– 650-W AC port-side exhaust (blue) (NXA-PAC-650W-PE)	2.42 lb (1.1 kg)	
– 650-W AC port-side intake (burgundy) (NXA-PAC-650W-PI)	2.42 lb (1.1 kg)	
– 1200-W HVAC/HVDC dual-direction (white) (N9K-PUV-1200W)	2.42 lb (1.1 kg)	
– 930-W DC port-side exhaust (gray) (UCS-PSU-6332-DC)	2.42 lb (1.1 kg)	
– 930-W DC port-side intake (green) (UCSC-PSU-930WDC)	2.42 lb (1.1 kg)	
– 930-W DC port-side exhaust (blue) (NXA-PDC-930W-PE)	2.42 lb (1.1 kg)	
– 930-W DC port-side intake (burgundy) (NXA-PDC-930W-PI)	2.42 lb (1.1 kg)	

Transceiver and Cable Specifications

To determine which transceivers, adapters, and cables are supported by this switch, see <https://www.cisco.com/c/en/us/support/interfaces-modules/transceiver-modules/products-device-support-tables-list.html>.

To see the transceiver specifications and installation information, see <https://www.cisco.com/c/en/us/support/interfaces-modules/transceiver-modules/products-device-support-tables-list.html>.

Switch Power Input Requirements

The following table lists the typical amount of power that the switch consumes. It also lists the maximum amount of power that you must provision for the switch and power supply for peak conditions.



Note Some power supplies have capabilities that are greater than the maximum power requirements for a switch. To determine the power consumption characteristics for the switch, use the typical and maximum requirements that are listed in the following table.

Switch	Typical Power Consumption (AC or DC)	Maximum Power Consumption (AC or DC)	Heat Dissipation Requirement
Cisco Nexus 93108TC-EX	290 W	499 W	1702.658 BTUs per hour

Power Specifications

Power specifications include the specifications for each type of power supply module.

650-W AC Power Supply Specifications

These specifications apply to the following power supplies:

- NXA-PAC-650W-PE
- NXA-PAC-650W-PI

Characteristic	Specification
AC input voltage	Nominal range: 100 and 240 VAC (Range: 90-132 VAC, 180-264 VAC)
AC input frequency	Nominal range: 50 to 60 Hz (Range: 47-63 Hz)
Maximum AC input current	7.6 A at 90 - 132 VAC 3.65 A at 180 - 264 VAC
Maximum input volt-amperes	760 VA at 100 VAC
Maximum output power per power supply	650 W
Maximum inrush current	33 A (sub-cycle duration)
Maximum hold-up time	12 ms at 650 W
Power supply output voltage	12 VDC
Power supply standby voltage	12 VDC
Efficiency rating	Climate Savers Platinum Efficiency (80Plus Platinum certified)
Form factor	RSP1

1200-W HVAC/HVDC Power Supply Specifications

These specifications apply to the 1200-W HVAC/HVDC (N9K-PUV-1200W) power supplies.

Characteristic	Specification
Input voltage <ul style="list-style-type: none"> • AC (for 1230 W output) • DC (for 1230 W output) 	Nominal (Range) <ul style="list-style-type: none"> • 200 to 277 VAC • -240 to -380 VDC
AC input frequency	Nominal: 50 to 60 Hz (Range: 47-63 Hz)

Characteristic	Specification
Maximum inrush current	35 A (cold turn on); 70 A (hot turn on)
Maximum output Watts <ul style="list-style-type: none"> • For 200 to 277 VAC • For 192 to 400 VDC 	Per power supply <ul style="list-style-type: none"> • 1230 W • 1230 W
Power supply output voltage <ul style="list-style-type: none"> • For 200 to 277 VAC • For 192 to 400 VDC 	Per power supply <ul style="list-style-type: none"> • 12 VAC at 100 A • 12 VDC at 100 A
Power supply standby voltage	12 V at 2.5 A
Efficiency rating	Climate Savers Platinum Efficiency (80Plus Platinum certified)
Form factor	RSP1

930-W DC Power Supply (Port-Side Intake) Specifications

These specifications apply to the 930-W DC (UCSC-PSU-930WDC) port-side intake power supplies.

Characteristic	Specification
DC input voltage range	Nominal range: -48 to -60 VDC nominal (Range: -40 to -60 VDC)
Maximum DC input current	23 A at -48 VDC
Maximum input W	1104 W
Maximum output power per power supply	930 W
Maximum inrush current	35 A (sub-cycle duration)
Maximum hold-up time	8 ms at 930 W
Power supply output voltage	12 VDC
Power supply standby voltage	12 VDC
Efficiency rating	Greater than 92% at 50% load
Form factor	RSP1

930-W DC Power Supply (Port-Side Exhaust) Specifications

These specifications apply to the 930-W DC (UCS-PSU-6332-DC) power supplies.

Characteristic	Specification
Maximum DC input current	23 A at -48 VDC
Maximum input W	1104 W
Maximum output power per power supply	930 W
Maximum inrush current	35 A at +35° Celcius
Maximum hold-up time	8 ms at 50 % load
Power supply output voltage	12 VDC
Power supply standby voltage	12 VDC
Efficiency rating	Climate Savers Platinum Efficiency (80Plus Platinum certified)
Form factor	1U

930-W DC Power Supply Specifications

These specifications apply to the following power supplies:

- NXA-PDC-930W-PE
- NXA-PDC-930W-PI

Characteristic	Specification
DC input voltage range	Nominal range: -48 to -60 VDC nominal (Range: -40 to -60 VDC)
Maximum DC input current	23 A at -48 VDC
Maximum input W	1104 W
Maximum output power per power supply	930 W
Maximum inrush current	35 A (sub-cycle duration)
Maximum hold-up time	8 ms at 930 W
Power supply output voltage	12 VDC
Power supply standby voltage	12 VDC
Efficiency rating	Greater than 92% at 50% load
Form factor	RSP1

Power Cable Specifications

The following sections specify the power cables that you can order and use with this switch.

AC Power Cables Supported by NX-OS Mode Switches

Power Type	Power Cord Part Number	Cord Set Description
	CAB-C13-C14-2M	Power Cord Jumper, C13-C14 Connectors, 6.6 feet (2.0 m)
	CAB-C13-CBN	Cabinet jumper power cord, 250 VAC, 10 A, C14-C13 connectors, 2.3 feet (0.7 m)
Argentina	CAB-250V-10A-AR	250 V, 10 A, 8.2 feet (2.5 m)
Australia	CAB-9K10A-AU	250 VAC, 10 A, 3112 plug, 8.2 feet (2.5 m)
Brazil	CAB-250V-10A-BR	250 V, 10 A, 6.9 feet (2.1 m)
European Union	CAB-9K10A-EU	250 VAC, 10 A, CEE 7/7 plug, 8.2 feet (2.5 m)
India	CAB-IND-10A	10 A, 8.2 feet (2.5 m)
India	CAB-C13-C14-2M-IN	Power Cord Jumper, C13-C14 Connectors, 6.6 feet (2.0 m)
Israel	CAB-250V-10A-IS	250 V, 10 A, 8.2 feet (2.5 m)
Italy	CAB-9K10A-IT	250 VAC, 10 A, CEI 23-16/VII plug, 8.2 feet (2.5 m)
Japan	CAB-C13-C14-2M-JP	Power Cord Jumper, C13-C14 Connectors, 6.6 feet (2.0 m)
North America	CAB-9K12A-NA	125 VAC, 13 A, NEMA 5-15 plug, 8.2 feet (2.5 m)
North America	CAB-AC-L620-C13	NEMA L6-20-C13, 6.6 feet (2.0 m)
North America	CAB-N5K6A-NA	200/240V, 6A, 8.2 feet (2.5 m)
Peoples Republic of China	CAB-250V-10A-CN	250 V, 10 A, 8.2 feet (2.5 m)
South Africa	CAB-250V-10A-ID	250 V, 10 A, 8.2 feet (2.5 m)
Switzerland	CAB-9K10A-SW	250 VAC, 10 A, MP232 plug, 8.2 feet (2.5 m)

Power Type	Power Cord Part Number	Cord Set Description
United Kingdom	CAB-9K10A-UK	250 VAC, 10 A, BS1363 plug (13 A fuse), 8.2 (2.5 m)
All except Argentina, Brazil, and Japan	NO-POWER-CORD	No power cord included with switch

HVAC/HVDC Power Cables Supported by ACI-Mode and NX-OS Mode Switches

Part Number	Cord Set Description	Photo
CAB-HVAC-SD-0.6M	HVAC 2-foot (0.6 m) cable with Saf-D-Grid and SD connectors 277V AC	
CAB-HVAC-C14-2M	HVAC 6.6-foot (2.0 m) cable with Saf-D-Grid and C14 (use for up to 240 V) connector 250V AC	
CAB-HVAC-RT-0.6M	HVAC 2-foot (0.6 m) cable with Saf-D-Grid and RT connector 277V AC	
CAB-HVDC-3T-2M	HVDC 6.6-foot (2.0 m) cable with Saf-D-Grid and three terminal connectors 300V AC / 400V DC (+200/-200 V DC)	
NO-POWER-CORD	All except Argentina, Brazil, and Japan No power cord included with switch	Not applicable

Table 2: HVAC/HVDC Power Cables Callout Table

1	Connect this end to the power supply unit.
---	--

DC Power Cable Specifications

The 930W DC power supply (UCS-PSU-6332-DC) is shipped with cable CAB-48DC-40A-8AWG.

The 930W DC power supply (UCSC-PSU-930WDC) is shipped with a connector in an accessory bag.

Part Number	Description	Photo
NXA-PDC-930W-PE/PI	The 930W DC power supply (NXA-PDC-930W-PE/PI) is shipped with cable CAB-48DC-40A-8AWG.	

Regulatory Standards Compliance Specifications

The following table lists the regulatory standards compliance for the switch.

Table 3: Regulatory Standards Compliance: Safety and EMC

Specification	Description
Regulatory compliance	Products should comply with CE Markings according to directives 2004/108/EC and 2006/95/EC.
Safety	<ul style="list-style-type: none"> • CAN/CSA-C22.2 No. 60950-1 Second Edition • EN 60950-1 Second Edition • IEC 60950-1 Second Edition • AS/NZS 60950-1 • GB4943

Specification	Description
EMC: Emissions	<ul style="list-style-type: none">• 47CFR Part 15 (CFR 47) Class A• AS/NZS CISPR22 Class A• CISPR22 Class A• EN55022 Class A• ICES003 Class A• VCCI Class A• EN61000-3-2• EN61000-3-3• KN22 Class A• CNS13438 Class A
EMC: Immunity	<ul style="list-style-type: none">• EN55024• CISPR24• EN300386• KN 61000-4 series
RoHS	The product is RoH-6 compliant with exceptions for leaded-ball grid-array (BGA) balls and lead press-fit connectors.



APPENDIX C

LEDs

- [Switch Chassis LEDs, on page 55](#)
- [Fan Module LEDs, on page 56](#)
- [Power Supply LEDs, on page 56](#)

Switch Chassis LEDs

The BCN, STS, and ENV, LEDs are located on the left side of the front of the switch. The port LEDs appear as triangles pointing up or down to the nearest port.

LED	Color	Status
BCN	Flashing blue	The operator has activated this LED to identify this switch in the chassis.
	Off	This switch is not being identified.
STS	Green	The switch is operational.
	Flashing amber	The switch is booting up.
	Amber	Temperature exceeds the minor alarm threshold.
	Red	Temperature exceeds the major alarm threshold.
	Off	The switch is not receiving power.
ENV	Green	Fans and power supply modules are operational.
	Amber	At least one fan or power supply module is not operating.

LED	Color	Status
(port)	Green	Port admin state is 'Enabled', SFP is present and the interface is connected (that is, cabled, and the link is up).
	Amber	Port admin state is 'Disabled', or the SFP is absent, or both.
	Off	Port admin state is 'Enabled' and SFP is present, but interface is not connected.

Fan Module LEDs



The fan module LED is located below the air holes on the front of the module.

LED	Color	Status
STS	Green	The fan module is operational.
	Red	The fan module is not operational (fan is probably not functional).
	Off	Fan module is not receiving power.

Power Supply LEDs

The power supply LEDs are located on the left front portion of the power supply. Combinations of states indicated by the Okay (🟢) and Fault (⚠️) LEDs indicate the status for the module as shown in the following table.

🟢 LED	⚠️ LED	Status
Green	Off	Power supply is on and outputting power to the switch.
Flashing green	Off	Power supply is connected to a power source but not outputting power to the switch—power supply might not be installed in the chassis.
Off	Off	Power supply is not receiving power.

 LED	 LED	Status
Green	Flashing amber	Power supply warning—possibly one of the following conditions: <ul style="list-style-type: none">• High voltage• High power• Low voltage• Power supply installed in chassis but not connected to a power source• Slow power supply fan



APPENDIX D

Additional Kits

- [Rack Mount Kit NXK-ACC-KIT-1RU](#), on page 59
- [Rack Mount Kit N3K-C3064-ACC-KIT](#), on page 60

Rack Mount Kit NXK-ACC-KIT-1RU

The following table lists and illustrates the contents for the 1-RU rack-mount kit (NXK-ACC-KIT-1RU).

Illustration	Description	Quantity
	Rack-mount kit <ul style="list-style-type: none"> • Front brackets (2) • Rear brackets (2) • Slider rails (2) • M4 Phillips pan-head screws (6) 	1
	Ground lug kit <ul style="list-style-type: none"> • Two-hole lug (1) • M4 x 8-mm Phillips pan-head screws (2) 	1
Not applicable	EAC Compliance document	1
Not applicable	Hazardous substances list for customers in China	1

The following table lists and illustrates the console cable (CAB-CONSOLE-RJ45) that can be ordered.

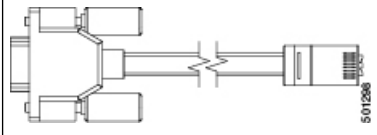
Illustration	Description	Quantity
	Console cable with DB-9F and RJ-45F connectors	1

Rack Mount Kit N3K-C3064-ACC-KIT

The following table lists and illustrates the contents for the 1-RU rack-mount kit (N3K-C3064-ACC-KIT).

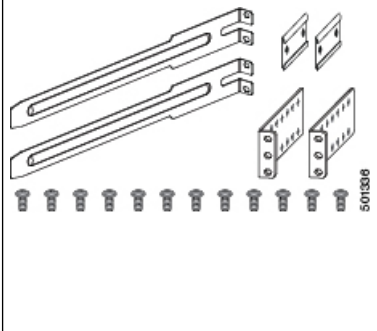
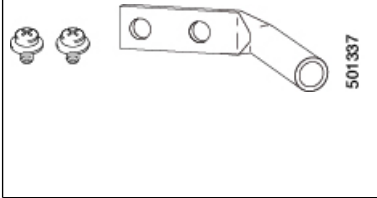
Illustration	Description	Quantity
	Rack-mount kit <ul style="list-style-type: none"> • Front-mount angled bracket (2) • Rear-mount slider bracket (2) • Slider rails (2) • M4 x 7 mm mounting screws (16) 	1
	Ground lug kit <ul style="list-style-type: none"> • Two-hole lug (1) • M4 x 8-mm Phillips pan-head screws (2) 	1
Not applicable	EAC Compliance document	1
Not applicable	Hazardous substances list for customers in China	1

The following table lists and illustrates the console cable (CAB-CONSOLE-RJ45) that can be ordered.

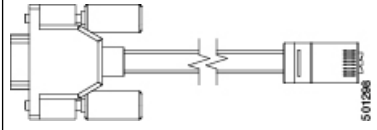
Illustration	Description	Quantity
	Console cable with DB-9F and RJ-45F connectors	1



APPENDIX **E**

Site Preparation and Maintenance Records

- [Site Preparation Checklist, on page 61](#)
- [Contact and Site Information, on page 62](#)
- [Chassis and Module Information, on page 63](#)

Site Preparation Checklist

Planning the location and layout of your equipment rack or cabinet is essential for successful switch operation, ventilation, and accessibility.

The following table lists the site planning tasks that we recommend that you complete before you install the switch. Your completion of each task ensures a successful switch installation.

Planning Activity	Verification Time and Date
Space evaluation:	
Space and layout	
Floor covering	
Impact and vibration	
Lighting	
Physical access	
Maintenance access	
Environmental evaluation:	
Ambient temperature	
Humidity	
Altitude	
Atmospheric contamination	
Airflow	

Planning Activity	Verification Time and Date
Power evaluation:	
Input power type	
Power receptacles	
Receptacle proximity to the equipment	
Dedicated (separate) circuits for power redundancy	
UPS for power failures	
Grounding: proper wire gauge and lugs	
Circuit breaker size	
Grounding evaluation:	
Data center ground	
Cable and interface equipment evaluation:	
Cable type	
Connector type	
Cable distance limitations	
Interface equipment (transceivers)	
EMI evaluation:	
Distance limitations for signaling	
Site wiring	
RFI levels	

Contact and Site Information

Use the following worksheet to record contact and site information for the installation.

Contact person	
Contact phone	

Contact e-mail	
Building/site name	
Data center location	
Floor location	
Address (line 1)	
Address (line 2)	
City	
State/Provence	
Contact person	
ZIP/postal code	
Country	

Chassis and Module Information

Use the following worksheet to record information about the switch.

Contract number	
Chassis serial number	
Product number	

Use the following worksheet to record network-related information.

Switch IP address	
Switch IP netmask	
Hostname	
Domain name	
IP broadcast address	
Gateway/router address	
DNS address	

Use the following worksheet to record information about the modules in the switch.

Module Slot	Module Type	Module Serial Number	Notes
Fan module 1			

Module Slot	Module Type	Module Serial Number	Notes
Fan module 2			
Fan module 3			
Fan module 4			
Power Supply 1			
Power Supply 2			