



Installing a Chassis

- [Installing a Rack or Cabinet, on page 1](#)
- [Inspecting the New Switch, on page 2](#)
- [Installing the Bottom-Support Rails, on page 3](#)
- [Installing a Chassis in a Rack or Cabinet, on page 6](#)
- [Grounding the Chassis, on page 11](#)
- [Starting Up the Switch, on page 12](#)

Installing a Rack or Cabinet

Before you install the switch, you must install a standard four-post, 19-inch (48.3-cm) EIA data center rack (or a cabinet that contains such a rack) that meets the requirements that are listed in [Rack and Cabinet Requirements](#).



Warning **Statement 1048**—Rack Stabilization

The rack stabilizing mechanism must be in place, or the rack must be bolted to the floor before installation or servicing. Failure to stabilize the rack can cause bodily injury.



Warning **Statement 1018**—Supply Circuit

To reduce risk of electric shock and fire, take care when connecting units to the supply circuit so that wiring is not overloaded.

-
- Step 1** Bolt the rack to the subfloor before moving the chassis onto it.
- Step 2** If the rack has bonded construction, connect it to the earth ground. This action enables you to ground the switch and its components and to ground your electrostatic discharge (ESD) wrist strap. This action prevents discharge damage when you handle ungrounded components during installation.
- Step 3** If you need access to the source power at the rack, include one of the following:

- For AC power, include an AC circuit that meets the power specifications of the switch, see [Power Requirements for Switch Modules](#). This circuit must include receptacles that match your local and national requirements and match the needs of the power cable that is used with the power supply unit.
- For DC power, include a DC circuit that meets the power specifications of the switch see [Power Requirements for Switch Modules](#)). This circuit must include a circuit breaker so that you can safely connect the power cables to the power supply.

Inspecting the New Switch

Before you install a new chassis, unpack and inspect it to be sure that you have all the items that you ordered. Verify that the switch was not damaged during shipment.



Caution When you handle the chassis or its components, you must follow ESD protocol to prevent ESD damage. This protocol includes but is not limited to wearing an ESD wrist strap that you connect to the earth ground.



Tip Do not discard the shipping container when you unpack the switch. Flatten the shipping cartons and store them with the pallet that was used for the system. If you move or ship the system in the future, you will need these containers.

Step 1 Compare the shipment to the equipment list that is provided by your customer service representative and verify that you have received your ordered items. The shipment includes boxes for the following:

- System chassis, which includes the following installed components:
 - Supervisor modules (1 or 2) of the following types (must be the same type):
 - Supervisor A (N9K-SUP-A)
 - Supervisor A+ (N9K-SUP-A+)
 - Supervisor B (N9K-SUP-B) (required for -R line cards and fabric modules)
 - Supervisor B+ (N9K-SUP-B+) (required for -R, -R2 line cards and -R, -R2 fabric modules)
 - System controllers (2) (N9K-SC-A)
 - Line cards (1 to 16 line cards) as described in the Overview in Chapter 1.
 - Fabric modules—See the Overview in Chapter 1 for quantity and type. The switch must have only one type of fabric module that supports the installed line cards.

The fabric modules must be installed in specific slots as follows (installing fabric modules in other slots can cause a module mismatch condition):

- For three modules, they must be in slots FM 2, FM 4, and FM 6.

- For four modules, they must be in slots FM 2, FM 3, FM 4, and FM 6.
- For five modules, they must be in slots FM 2, FM 3, FM 4, FM 5, and FM 6.
- For six modules, they are in slots FM 1, FM 2, FM 3, FM 4, FM 5, and FM 6.
- Fan trays (3)
- Power supplies (1 to 10)
 - 3-kW AC power supply (N9K-PAC-3000W-B)
 - 3-kW Universal AC/DC power supply (N9K-PUV-3000W-B)
 - 3.15-kW Dual Input Universal AC/DC power supply (N9K-PUV2-3000W-B)
 - 3-kW DC power supply (N9K-PDC-3000W-B)
- Rack Mount kit
 - Rack mount kit for the Cisco Nexus 9516 (N9K-C9500-RMK) chassis
 - Bottom-support rails (2)
 - M6 mounting screws (20)
 - 10-32 mounting screws (20)
 - 12-24 mounting screws (20)
 - Switch accessory kit (N9K-ACC-KIT)

Step 2 Check the contents of each box for damage.

Step 3 If you notice any discrepancies or damage, send the following information to your customer service representative by email:

- Invoice number of the shipper, see the packing slip.
- Model and serial number of the missing or damaged unit
- Description of the problem and how it affects the installation.
- Photos of the damage to external packaging, internal packaging, and product

Installing the Bottom-Support Rails

The bottom-support rails support the weight of the switch chassis in the rack or cabinet. To maximize the stability of the rack, you must attach these rails at the lowest possible rack unit (RU).



Warning Statement 1006—Chassis Warning for Rack-Mounting and Servicing

To prevent bodily injury when mounting or servicing this unit in a rack, you must take special precautions to ensure that the system remains stable. The following guidelines are provided to ensure your safety:

- This unit should be mounted at the bottom of the rack if it is the only unit in the rack.
 - When mounting this unit in a partially filled rack, load the rack from the bottom to the top with the heaviest component at the bottom of the rack.
 - If the rack is provided with stabilizing devices, install the stabilizers before mounting or servicing the unit in the rack.
-

Before you begin

Before you can install the bottom support rails for the chassis, you must do the following:

- Verify that a four-post rack or cabinet is installed and secured to the concrete subfloor, see [Installing a Rack or Cabinet](#).
- If any other devices are stored in the rack or cabinet, verify that they are located below where you plan to install the switch. Also, verify that lighter devices in the same rack are located above where you plan to install this switch.
- Verify that the bottom-support rails kit is included in the switch accessory kit, see [Inspecting the New Switch](#).

Step 1

Position one of the two adjustable bottom-support rails at the lowest possible RU in the rack or cabinet. Adjust the length of each rail so that it stretches from the outer edges of the front and rear vertical mounting rails on the rack. Be sure that there is at least 21 RU (36.7 inches [93.4 cm]) of vertical space above the rails to install the chassis, see the following figure.

You can expand the rail so that its mounting brackets are spaced between 24 to 32 inches (61.0 to 81.3 cm).

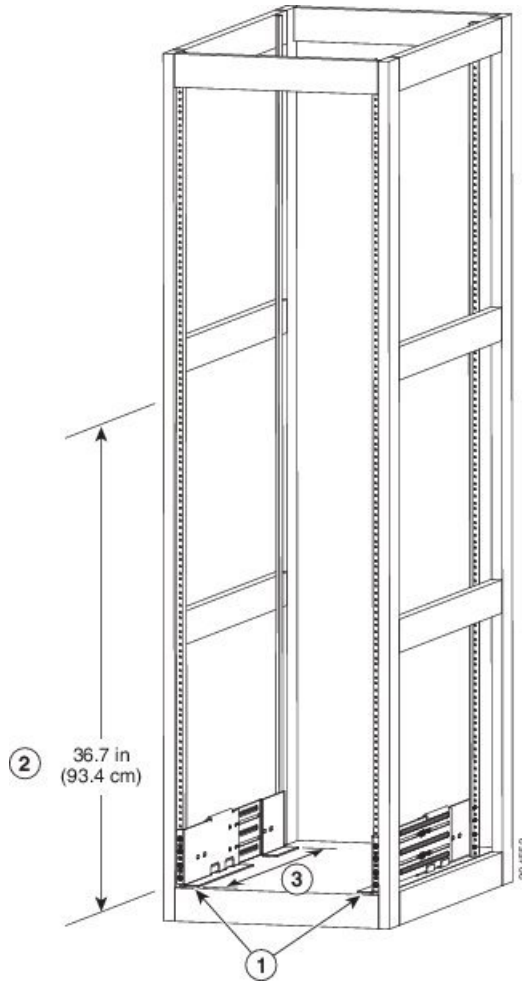

1	Position 2 bottom-support rails at the lowest RU on the rack.	3	Distance between front and rear vertical rails must be 24 to 32 inches (61.0 to 81.3 cm).
2	Allow at least 21 RU (36.7 inches [93.4 cm]) for each chassis.		

Step 2

Attach the bottom-support rail to the rack or cabinet using a Phillips torque screwdriver on three M6 x 19 mm or 12-24 x 3/4 inch screws for each end of the rail (using a total of 6 screws for the rail as shown in the following figure) and tighten each screw to 40 in-lbs (4.5 N.m) of torque.

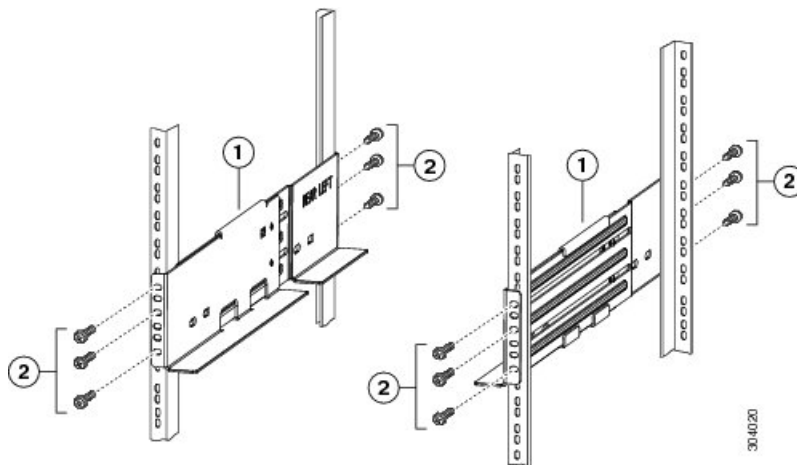

1	Adjustable bottom-support rails (2)	2	M6 x 19-mm (or 12-24 x 3/4 in.) Phillips screws (at least 6 per rail)
---	-------------------------------------	---	---

Note Use at least three screws on each end of each bottom-support rail.

Step 3 Repeat Steps 1 and 2 to attach the other bottom-support rail to the rack.

Note Make sure that the two bottom-support rails are level with one another. If they are not level, adjust the higher rail down to the level of the lower rail.

What to do next

When the bottom-support rails are installed at the lowest possible RU and are level, you are ready to install the chassis in the rack or cabinet.

Installing a Chassis in a Rack or Cabinet

To move a chassis to a rack, it is necessary to slide the chassis onto a mechanical lift. Use a mechanical lift to position the chassis in front of its place on the rack. Slide the chassis from the lift to the rack. Then bolt the chassis to the rack. You can make the chassis easier to move if you remove the power supplies, fan trays, and fabric modules. Modules are sealed to minimize the chance of damage by electrostatic discharge (ESD). You can remove modules from the chassis to make the chassis easier to move.

Before you begin

- You have fully installed a rack or cabinet (see [Installing a Rack or Cabinet](#)).



Warning Statement 1048—Rack Stabilization

Stability hazard. The rack stabilizing mechanism must be in place, or the rack must be bolted to the floor before you slide the unit out for servicing. Failure to stabilize the rack can cause the rack to tip over.

- You have installed the bottom-support rails to the lowest possible RU in the rack. And there is at least 21 RU (36.7 inches [93.4 cm]) of space above the rails to install the chassis.
- Data center ground is accessible where you are installing the chassis.
- If there are other devices in the rack, ensure that the heavier devices are installed below the location that you are going to install the chassis.
- You have unpacked and inspected the chassis shipment for completeness and damage (see [Inspecting the New Switch](#))
- You have the following tools and equipment:
 - Mechanical lift capable of lifting the weight of the chassis and the modules, fan trays, and power supplies installed in it. Fully loaded, the switch weighs up to 442 lb (200 kg). To determine the full weight of your chassis with its modules installed (or the weight if you remove the protected modules), see [Weights for the Chassis, Modules, Fan Trays, and Power Supplies](#) .



Caution Use a mechanical lift to lift anything weighing over 120 pounds (55 kg).

- Number 1 Phillips-head torque screwdriver
- Eight 12-24 x 3/4-inch or M6 x 19 mm Phillips screws from the bottom-support rails kit



Note Have at least three persons to move the chassis, which can weigh up to 568 lb (258 kg), onto and off the mechanical lift and rack.



Warning Statement 1006—Chassis Warning for Rack-Mounting and Servicing

To prevent bodily injury when mounting or servicing this unit in a rack, you must take special precautions to ensure that the system remains stable. The following guidelines are provided to ensure your safety:

- This unit should be mounted at the bottom of the rack if it is the only unit in the rack.
 - When mounting this unit in a partially filled rack, load the rack from the bottom to the top with the heaviest component at the bottom of the rack.
 - If the rack is provided with stabilizing devices, install the stabilizers before mounting or servicing the unit in the rack.
-



Warning Statement 1074—Comply with Local and National Electrical Codes

Installation of the equipment must comply with local and national electrical codes.

Step 1 Make the chassis as light as possible for moving. Remove the following modules and place them where their connectors will not be damaged:

- Power supplies—For each power supply, press and hold the eject lever, and use the handle on the front of the power supply to remove the module.
- Fan trays—Unscrew the four captive screws, and use the two handles on the fan tray to remove the module.
- Fabric modules—For each fabric module, press both eject buttons on the front, rotate both levers away from the front of the module, and use the levers to remove the module.

Step 2 Load the chassis onto a mechanical lift as follows:

- a) Position the mechanical lift next to the shipping pallet that holds the chassis.
- b) Elevate the lift platform to the level of the bottom of the chassis (or no more than 1/4 inch [0.635 cm] below the bottom of the chassis).
- c) Use at least four people to slide the chassis fully onto the lift so that the side of the chassis touches or is close to the vertical rails on the lift. Make sure that the front and rear of the chassis are unobstructed so you can easily push the chassis into the rack.

Warning Statement 1032—Lifting the Chassis

To prevent personal injury or damage to the chassis, never attempt to lift or tilt the chassis using the handles on modules (such as power supplies, fans, or cards); these types of handles are not designed to support the weight of the unit.

Step 3 Use the mechanical lift to position the chassis in front of the four-post rack or cabinet. Elevate the chassis to the level of the bottom-support rails or no more than 1/4 inch (0.6 cm) above the bracket.

Step 4 Position the chassis with the rear (the side with the open power supply slots) ready to go into the rack or cabinet. If necessary, you can use the two handles on either side of the chassis to move the chassis on the lift.

Step 5 Use two people to push the chassis halfway onto the rack or cabinet. Have one person to guide the chassis down the bottom-support rails while making sure that the chassis does not get caught on any edges of the bottom support brackets.

Push only the lower front sides of the chassis—do not push any modules and do not use any module handles to move the chassis.

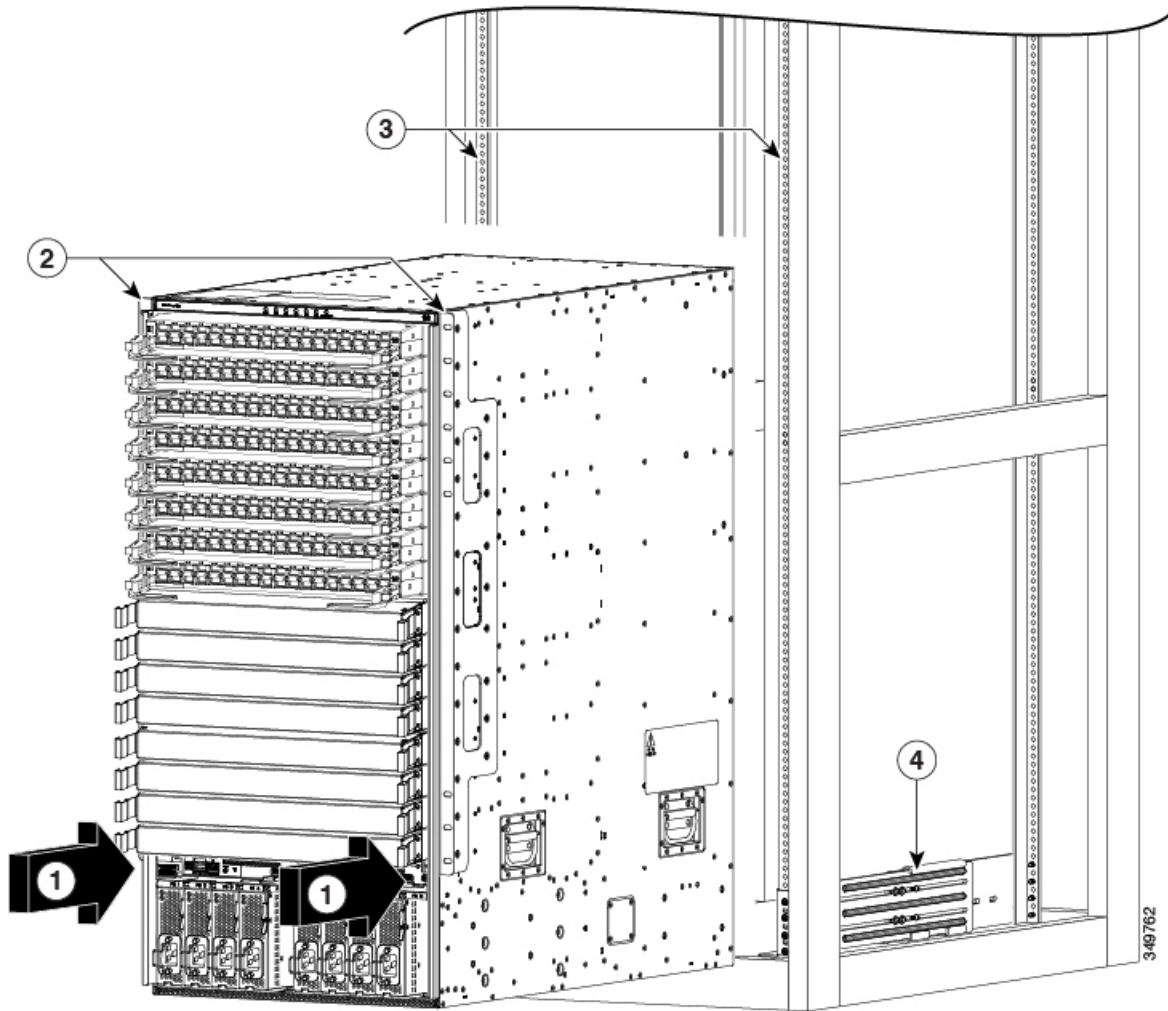

1	Push the sides of the lower half of the front side of the chassis (do not push or lift any of the modules or module handles).	3	Rack vertical mounting rails.
2	Chassis mounting brackets.	4	Bottom-support rails

Step 6 If the mechanical lift is raised above the bottom-support rails, gently lower the lift to the level of the brackets or no more than 1/4 inch (0.6 cm) below the rails.

This action keeps the chassis level on the rails and helps prevent the chassis from getting caught on the inside edges of the bottom-support rails.

Step 7 Use two people to push the chassis all the way onto the rack or cabinet.

You have pushed the chassis all the way when its two vertical mounting brackets come in contact with the vertical rails on the rack or cabinet.

Step 8 Align the mounting bracket on the chassis to the vertical mounting rails on the rack, and attach the chassis to the rack.

Align the screw holes in the chassis mounting brackets to the screw holes in the vertical mounting rails on the rack or cabinet. Use a Phillips screwdriver to screw in four M6 x 19-mm or 12-24 x 3/4-inch screws in each of the two chassis mounting brackets (use a total of eight screws for two mounting brackets).

Tip To adjust the placement of the chassis on the bottom-support rails, use the chassis handles.

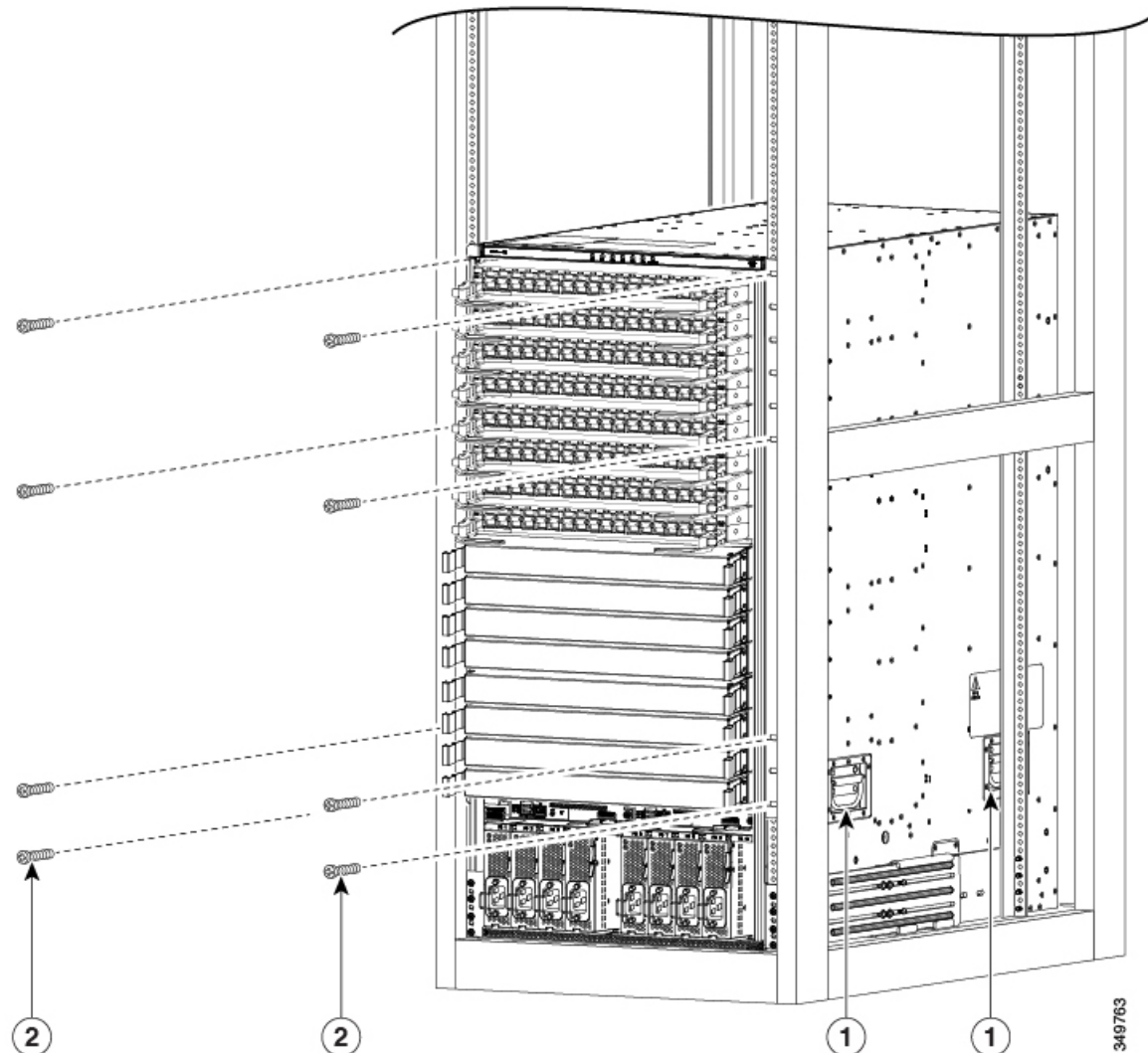

1	Handles used to adjust the chassis placement.	2	Four M6 x 19 mm or 10-24 x 3/4 in. Phillips screws that are used to attach each side bracket to a front mounting rail (use a total of eight screws).
---	---	---	--

Step 9 To reinstall the fabric modules, see [Installing a Fabric Module](#)

Step 10 To reinstall the fan trays, see [t_n95xx_install_fan_tray.xml](#)

What to do next

After the chassis is secured to the rack, you can ground the switch (see [Grounding the Chassis, on page 11](#)).

Grounding the Chassis

The switch chassis is automatically grounded when you properly install the switch in a grounded rack with metal-to-metal connections between the switch and rack.



Note An electrical conducting path shall exist between the product chassis and the metal surface of the enclosure or rack in which it is mounted or to a grounding conductor. Electrical continuity shall be provided by using thread-forming type mounting screws that remove any paint or non-conductive coatings and establish a metal-to-metal contact. Any paint or other non-conductive coatings shall be removed on the surfaces between the mounting hardware and the enclosure or rack. The surfaces shall be cleaned and an antioxidant applied before installation.

You can also ground the chassis, which is required if the rack is not grounded, by attaching a customer-supplied grounding cable. Attach the cable to the chassis grounding pad and the facility ground.



Warning Statement 1024—Ground Conductor

This equipment must be grounded. To reduce the risk of electric shock, never defeat the ground conductor or operate the equipment in the absence of a suitably installed ground conductor. Contact the appropriate electrical inspection authority or an electrician if you are uncertain that suitable grounding is available.



Warning Statement 1046—Installing or Replacing the Unit

To reduce risk of electric shock, when installing or replacing the unit, the ground connection must always be made first and disconnected last.

Before you begin

Before you can ground the chassis, you must have a connection to the earth ground for the data center building.

-
- Step 1** Use a wire-stripping tool to remove approximately 0.75 inch (19 mm) of the covering from the end of the grounding wire. We recommend 6-AWG wire for the U.S. installations.
- Step 2** Insert the stripped end of the grounding wire into the open end of the grounding lug. Use a crimping tool to crimp the lug to the wire, see the following figure. Verify that the ground wire is securely attached to the grounding lug by attempting to pull the wire out of the crimped lug.

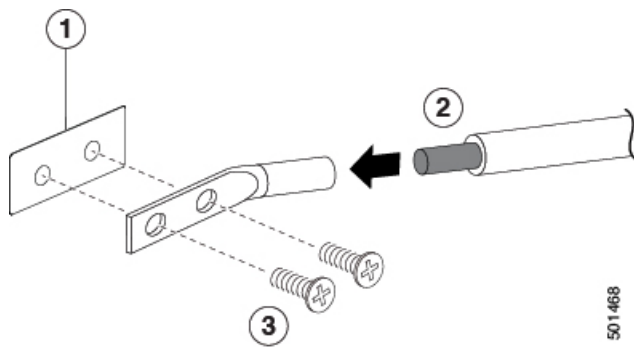

1	Chassis grounding pad	3	2 M4 screws are used to secure the grounding lug to the chassis
2	Grounding cable, with 0.75 in. (19 mm) of insulation that is stripped from one end, which is inserted into the grounding lug and crimped in place		

Step 3 Secure the grounding lug to the chassis grounding pad with two M4 screws, see the previous figure. Tighten the screws to 11 to 15 in-lb (1.24 to 1.69 N·m) of torque.

Step 4 Prepare the other end of the grounding wire and connect it to the facility ground.

Starting Up the Switch

Before you can turn on the switch, you must ensure the following:

- The switch has enough power supplies to output the amount of wattage that is required for all the modules that are installed in the switch. Depending on the power mode that you use for the switch, consider the following:
 - For combined power mode (no power redundancy), there must be enough power supplies to power all the modules in the chassis. No extra power supplies are needed for redundancy.
 - For $n+1$ redundancy mode, there must be enough power supplies to power all the modules in the chassis. And there must be one extra power supply to provide redundancy if one power supply goes down or is replaced. The maximum number of power supplies that are needed is the number that is used for combined power mode plus one ($n+1$) for redundancy.
 - For $n+n$ redundancy mode, there must be two equal sets of power supplies. Each of which can power all the modules in the chassis and each set is connected to a separate power source. If one power source goes down, the power supplies connected to the other power source can power the switch. The maximum number of power supplies is the number of power supplies that are required for combined power plus the same number of power supplies ($n+n$) for redundancy.



Note DC power supplies have two power feeds, each with a positive (+) wire and a negative (-) wire. For simpler routing of power cables, you connect both feeds to the same power source. Alternatively, you can connect each feed to a separate power source but that makes the routing of power cables more complicated.



Note This Equipment is designed to boot up in less than 30 minutes, dependent on its neighboring devices being fully up and running.

- When using two power sources, it is easiest to manage the routing of power cables separately. Route the power cables for one power source along the left side of the chassis. Route the power cables for the other power source along the right side of the chassis. The power cables on the left side connect to power supplies in the far left power supply slots. The power cables on the right side connect to power supplies in the far right power supply slots. If you are not filling all the power supply slots, fill the slots on the sides for now and leave the middle slots open. Cover each open slot with a power supply slot blank to preserve the designed airflow, until you add more power supplies.

You turn on the switch when you connect its power supplies to one or two power sources.



Warning **Statement 1004**—Installation Instructions

Read the installation instructions before using, installing or connecting the system to the power source.



Warning **Statement 1018**—Supply Circuit

To reduce risk of electric shock and fire, take care when connecting units to the supply circuit so that wiring is not overloaded.

Connecting a 3-kW AC Power Supply to an AC Power Source

-
- Step 1** For each 3-kW AC power supply, connect an AC power cable to the AC power source and to the power receptacle on the power supply.
- Step 2** Verify that the Output Power LED turns on and becomes green.
-

What to do next

When the power supplies are operating and the switch is fully powered, you are ready to connect the switch to the network.

Connecting a 3-kW Universal AC/DC Power Supply to an AC Power Source

The 3-kW Universal AC/DC power supply can be connected to either a 200-to-277-V AC circuit equipped with a Saf-D-Grid receptacle. This procedure is for connecting the power supply to an AC power source.

Before you begin

The power switch on the power supply must be turned off (power switch set to 0).

-
- Step 1** Verify that the power switch on the power supply is turned off (0).
 - Step 2** Connect the Saf-D-Grid connector on the AC power cable to the Saf-D-Grid receptacle for the AC power source.
 - Step 3** Connect the Saf-D-Grid connector on the other end of the power cable to the Saf-D-Grid receptacle on the power supply.
 - Step 4** Turn on the power supply by pressing its power switch to on (1).
 - Step 5** Verify that the Output Power LED turns on and becomes green.
-

What to do next

After you finish connecting the power supplies to the power source and the power supplies are operating, you connect the switch to the network.

Connecting a 3-kW Universal AC/DC Power Supply to a DC Power Source

The 3-kW Universal AC/DC power supply can be connected to a 240-to-380-V DC circuit equipped with positive, negative, and ground terminals. This procedure is for connecting the power supply to a DC power source.

Before you begin

- The DC power source must be turned off at its circuit breaker.
- The power switch on the power supply must be turned off (power switch set to 0).

-
- Step 1** Verify that the circuit breaker for the DC power source is turned off.
 - Step 2** Verify that the power switch on the power supply is turned off (0).
 - Step 3** Connect the ground terminal ring on the power cable to the ground terminal on the DC power source. Secure it in place with a nut tightened to the appropriate torque setting for the terminal post.
 - Step 4** Connect the negative terminal ring on the power cable to the negative (-) terminal on the DC power source. Secure it in place with a nut tightened to the appropriate torque setting for the terminal post.
 - Step 5** Connect the positive terminal ring on the power cable to the positive (+) terminal on the DC power source. Secure it in place with a nut tightened to the appropriate torque setting for the terminal post.
 - Step 6** Connect the Saf-D-Grid connector on the other end of the power cable to the Saf-D-Grid receptacle on the power supply.
 - Step 7** Turn on the circuit breaker for the DC power source circuit.
 - Step 8** Turn on the power supply by pressing its power switch to on (1).

Step 9 Verify that the Output Power LED turns on and becomes green.

What to do next

After you finish connecting the power supplies to the power source and the power supplies are operating, you connect the switch to the network.

Connecting a 3-kW DC Power Supply to a DC Power Source

For no power redundancy or $n+1$ power redundancy, you connect the power supplies in the switch to the same power grid. For $n+n$ power redundancy, you connect half of the power supplies to one power grid and the other half of power supplies to another power grid. Grid A power supplies are on the left side of the switch and grid B power supplies are on the right side of the switch).

Before you begin

- The power supplies must be installed in the chassis.
- The power supplies must be close enough to be connected to the DC power source using the customer-provided power cables.
- Four 6-AWG lugs that are provided with the switch.
- Customer-provided equipment and tools must include the following:
 - Four power cables (6-AWG cables recommended).



Note Use colored cables to designate positive and negative polarity. You need two cables that are colored for positive polarity and two cables that are colored for negative polarity.

- Wire stripping tool
- Crimping tool
- Torque screwdriver and wrench

Step 1 Turn off the switch and circuit breaker as follows:

- a) Turn the power switch on the power supply to standby (labeled 0 on the power supply).
- b) Turn off the circuit breaker for each of the two power inputs coming from the DC power source.

Warning Statement 1003—DC Power Disconnection

Before performing any of the following procedures, ensure that power is removed from the DC circuit.

Step 2 Connect the four customer-provided power cables to the power supply and power source as follows:

- a) Use a wire stripper to remove 0.75 inches (19 cm) of insulation from the end of each of four power cables.

Use colored cables to designate positive and negative polarity. You need two cables that are colored for positive polarity and two cables that are colored for negative polarity.

- b) Use a crimping tool to attach each of four lugs (provided with the switch for each power supply) to the stripped end of each cable.

Test each crimped lug by trying to pull it off its cable.

- c) Use a torque screwdriver to unscrew the three screws that are on the cover of the terminal box. the cover is located on the front of the power supply and lifts off the cover as shown in the following figure.

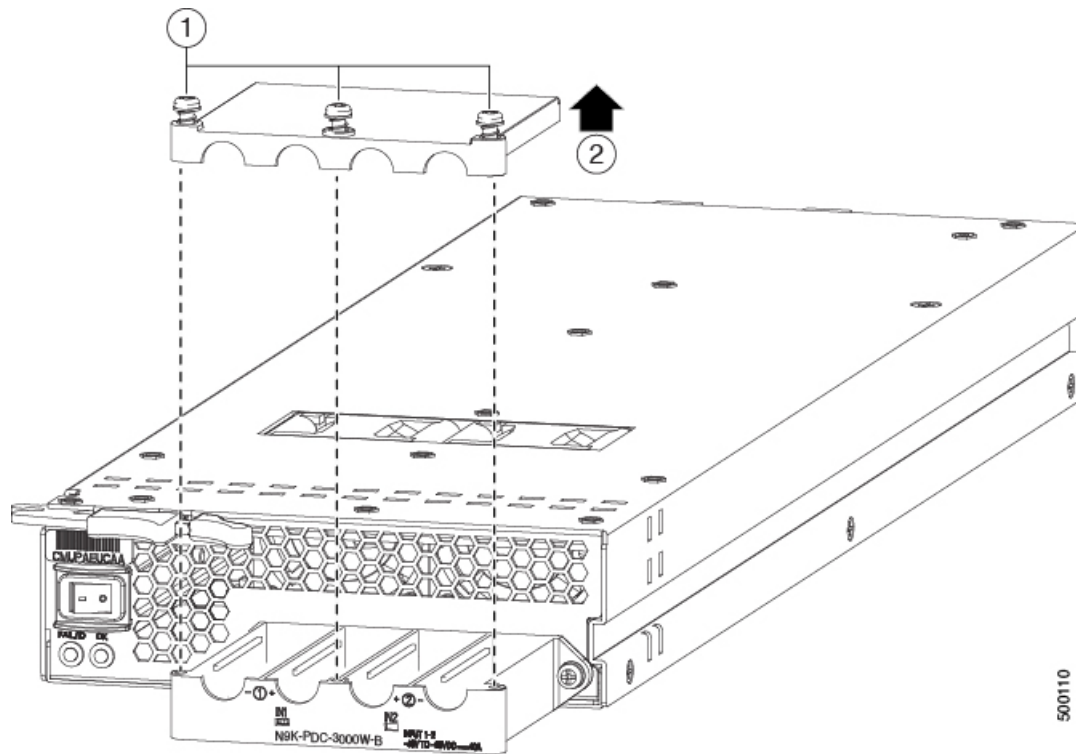

1	Unscrew three screws on the safety cover.	2	Remove the cover.
---	---	---	-------------------

Note The terminal box has four slots for four power terminals (ordered as negative [-], positive [+], positive [+], and negative [-]). Each terminal has two nuts that you use to fasten a power cable to the terminal.

- d) Remove the two nuts from each terminal post in each slot of the terminal box.
 e) Place each of the lugs for the two positive cables on the two middle terminal posts and fasten each lug using two nuts. Then tightened to 40 in-lb (4.5 N·m) of torque.
 f) Place each of the lugs for the two negative cables on the two side terminal posts and fasten each lug with two nuts. Then tightened to 40 in-lb (4.5 N·m) of torque.
 g) Replace the safety cover on the terminal box and fasten it in place using its three screws.
 h) Connect the other ends of the power cables to the two DC power circuits.

Be sure that the positive and negative cables that are attached to one side of the power supply are attached to the same DC power source circuit. The negative cable is attached to a negative terminal and the positive cable is attached to a positive terminal).

Step 3

Power up the power supply as follows:

- a) Turn on the power source circuit breaker for both input lines.

Verify that the Input 1 (IN1) and Input 2 (IN2) LEDs light up on the power supply.

- b) Turn the power switch on the power supply to ON (labeled 1 on the power supply).

The LEDs flash and then the OK LED turns on (green) in addition to the Input LEDs.

What to do next

You are ready to connect the switch to the network.

