



Replacing or Installing Modules, Fan Trays, and Power Supplies

- [Preventing Electrostatic Damage, on page 1](#)
- [Installing or Replacing a Supervisor Module, on page 1](#)
- [Installing or Replacing a System Controller Module, on page 5](#)
- [Installing or Replacing a Line Card, on page 7](#)
- [Replacing a Fan Tray, on page 10](#)
- [Replacing a Fabric Module, on page 13](#)
- [Installing or Replacing Power Supplies, on page 22](#)

Preventing Electrostatic Damage

To prevent electrostatic damage (ESD) to electronic components, you must be sure that you are grounded while handling electronic components. Components include, but are not limited to all switch modules.

Before you begin

The switch must be connected to the facility earth ground.

-
- Step 1** Attach an ESD wristband to your arm and be sure that it touches your skin.
 - Step 2** Attach the alligator clip on the other end of the strap to the grounding cable for the switch.
 - Step 3** Verify that the grounding cable is attached to the facility earth ground.
-

Installing or Replacing a Supervisor Module

The switch can operate with one or two supervisor modules that are installed in the chassis.

When you remove the active supervisor, the switch automatically makes the other supervisor active and makes the module that you are removing the standby supervisor. If the switch has only one installed supervisor module, you can install the new supervisor in the empty supervisor slot during operations.



Note If there are two supervisors that are installed in the chassis, both must be the same type as shown in the following table:

Active Supervisor	Standby Supervisor	Is Combination Allowed?
Supervisor A	Supervisor A	Yes
Supervisor B	Supervisor B	Yes
Supervisor A+	Supervisor A+	Yes
Supervisor B+	Supervisor B+	Yes



Warning Statement 1029—Blank Faceplates and Cover Panels

Blank faceplates and cover panels serve three important functions: they prevent exposure to hazardous voltages and currents inside the chassis; they contain electromagnetic interference (EMI) that might disrupt other equipment; and they direct the flow of cooling air through the chassis. Do not operate the system unless all cards, faceplates, front covers, and rear covers are in place.



Warning Statement 1034—Backplane Voltage

Hazardous voltage or energy is present on the backplane when the system is operating. Use caution when servicing.

Before you begin

- Wear an electrostatic discharge (ESD) wrist strap or other ESD protective device while handling modules.
- Prepare an antistatic surface or packing materials for each module that you remove from the chassis.

Step 1 Open the packaging for the new supervisor module. Inspect the module for damage. Verify that the module is the same type as the other supervisor module installed in the chassis.

If the module is damaged, alert the Technical Assistance Center (TAC).

Step 2 If you are installing the module in an empty slot, remove the blank module that is already in that slot. Unscrew its captive screw and pull it out of the slot. Go to Step 4.

Step 3 If you are replacing a module that is currently in the chassis, remove the existing module from the chassis by following these steps:

- a) Disconnect and label the following cables from the module:
 - Console cable
 - Ethernet Management cable

- b) If there are any external drives that are attached to the module through its USB ports, detach those drives.
- c) Slide the middle section of the ejector handle toward the end of the handle and rotate the handle away from the front of the module. See Callouts 1 and 2 in the following figure.

The module unseats its connectors from the midplane and moves slightly out of the chassis.

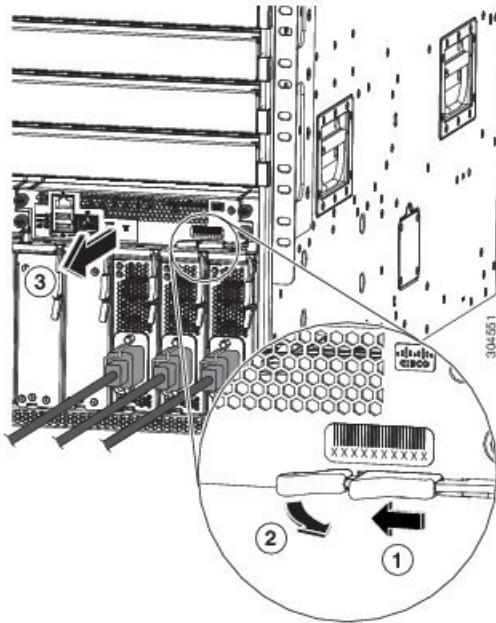

1	Slide the middle handle toward the end of the ejector lever.	3	Pull on the lever to slide the module part way out of the chassis. Release the lever, hold the front of the module, and pull the module all the way out of the chassis.
2	Rotate the ejector lever away from the module.		

- d) Use one hand to hold the front of the module, place your other hand under the module to support its weight, and pull the module out of the chassis. Set it on an antistatic surface or inside an antistatic bag.

Step 4

To install the new module, follow these steps:

- a) Pull the middle section of the ejector handle toward the end of the handle and rotate the handle away from the front of the module.

This action opens the lever so that the module can be fully inserted into the slot.

- b) Hold the front of the module with one hand and place your other hand under the module to support its weight.
- c) Align the back of the module to the guides in the open supervisor slot and slide the module all the way into the slot. See the following figure.

The module stops when its front is about 0.25 inches (0.6 cm) outside the front of the chassis.

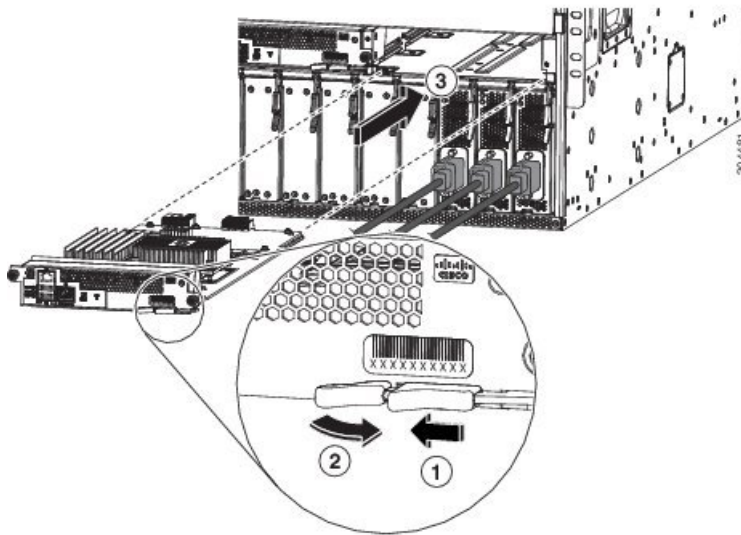

1	Slide the middle handle toward the end of the ejector lever.	3	Slide the back end of the module into the open supervisor slot.
2	Rotate the ejector lever away from the module.		

d) Rotate the lever all the way to the front of the chassis until it locks in place with a click.

Make sure that the lever engages behind the front of the slot so that the module fully seats onto the connectors on the midplane.

e) Screw in the two captive screws to secure the module to the chassis. Tighten the screws to 8 in-lb (0.9 N·m) of torque.

f) Attach the following cables to the module:

- Console cable—Attach to the Console port.
- Management cable—Attach to the Management Ethernet port.

g) Verify that the supervisor module LEDs turn on and appear as follows:

- The Status (STS) LED is green.
- The Active (ACT) LED is amber or green.

Upgrading a Supervisor Module

You can upgrade supervisor modules by using the hot swap method. The upgrade path for your active supervisor module can be found in the following table:

Active Supervisor	Allowed Upgrade
Supervisor A	Supervisor A+
Supervisor A	Supervisor B+

Active Supervisor	Allowed Upgrade
Supervisor B	Supervisor B+

Step 1 Insert the new supervisor module in the empty slot.

Step 2 Bring up the new supervisor module:

- a) If the newly inserted supervisor module becomes stuck in the loader prompt, use the `reload module <x> force-dnld` command on the active supervisor module. This action brings up the new supervisor module.
- b) If the newly inserted supervisor module has an older BIOS (<5.20), and is unable to boot, you will have to upgrade the BIOS. Use the `flwr tftp|usb<x>://<ip>/img_name1` command, from the newly inserted supervisor module loader prompt. Then use the `reload module <x> force-dnld` command from the active supervisor module to bring up the new supervisor module.

Step 3 Once the new supervisor module has been brought up in `ha-stby` mode, do a copy `r s`. Then issue a system switchover.

Installing or Replacing a System Controller Module

The switch can operate with one or two system controller modules that are installed in the chassis. You can replace one system controller module while there is another one installed in the chassis.



Warning Statement 1029—Blank Faceplates and Cover Panels

Blank faceplates and cover panels serve three important functions: they prevent exposure to hazardous voltages and currents inside the chassis; they contain electromagnetic interference (EMI) that might disrupt other equipment; and they direct the flow of cooling air through the chassis. Do not operate the system unless all cards, faceplates, front covers, and rear covers are in place.



Warning Statement 1034—Backplane Voltage

Hazardous voltage or energy is present on the backplane when the system is operating. Use caution when servicing.

Before you begin

- Wear an electrostatic discharge (ESD) wrist strap or other ESD protective device while handling modules.
- Prepare an antistatic surface or packing materials for each module that you remove from the chassis.

Step 1 Open the packaging for the new system controller module and inspect the module for damage.

If the module is damaged, alert the Technical Assistance Center (TAC).

Step 2 If you are installing the module in an empty slot, remove the blank module that is already in that slot. Unscrew its captive screw and pull it out of the slot. Go to Step 4.

Step 3 If you are replacing a module that is currently in the chassis, remove the existing module from the chassis by following these steps:

- a) Unscrew the two captive screws (one on each side of the module) until the screws are no longer in contact with the chassis.
- b) Slide and hold the middle handle on the ejector lever toward the end of the lever.
- c) Rotate the ejector lever away from the front of the module.

As you rotate the lever, the module unseats from the midplane and moves slightly forward.

- d) Use the lever to pull the module a couple of inches (about 5 cm) out of the slot.
- e) Use one hand to hold the front of the module, place your other hand under the module to support its weight, pull the module out of the chassis. Set it on an antistatic surface or inside an antistatic bag.

Step 4 To install the new module, follow these steps:

- a) Slide and hold the middle handle on the ejector lever toward the end of the lever. See the following figure.

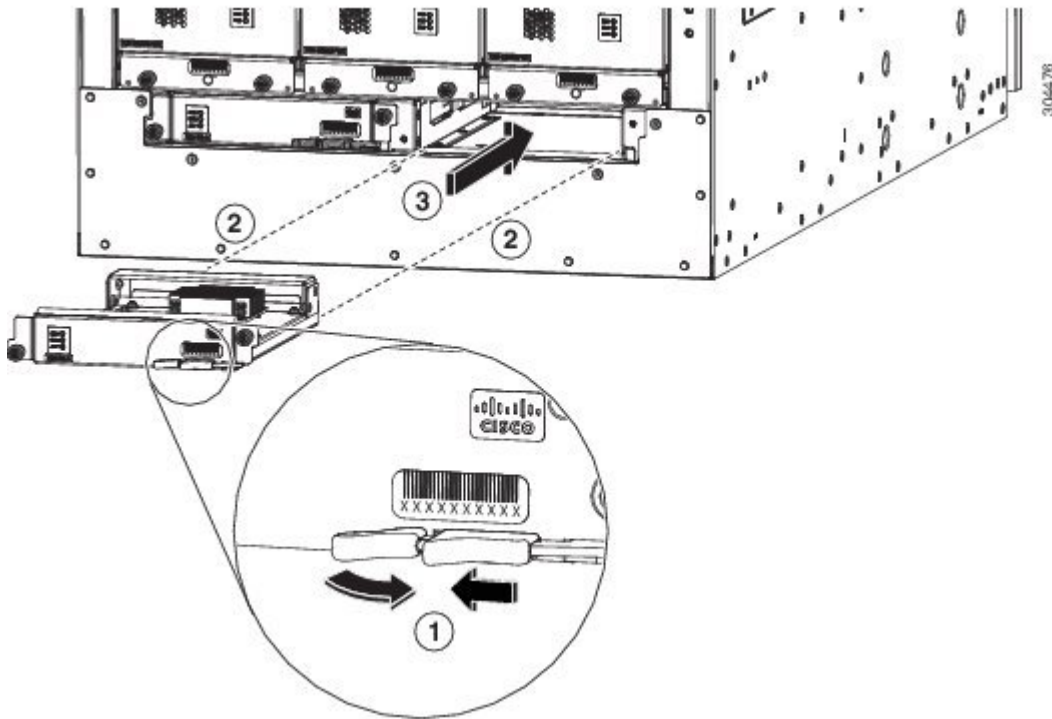

1	Slide the middle handle on the ejector lever to the end of the lever and rotate the lever away from the module.	3	Slide the module all the way into the chassis.
2	Align the back of the module to the open slot in the chassis.		

- b) Hold the front of the module with one hand and place your other hand under the module to support it.
- c) Align the back of the module to the guides in the open controller slot and slide the module all the way into the slot.

The module stops when its front is about 0.25 inches (0.6 cm) outside the front of the chassis.

- d) Rotate the ejector lever all the way to the front of the chassis until it locks in place with a click.

The module is fully seated on the midplane.

- e) Screw in the two captive screws to secure the module to the chassis. Tighten each of these screws to 8 in-lb (0.9 N·m) of torque.
f) Verify that the Status (STS) LED turns on and becomes green.

Installing or Replacing a Line Card

The switch can operate with one or more line cards that are installed in the chassis. If there is at least one line card that is installed and operating in the chassis, you can replace another line card or install a new line card in an empty line card slot.



Warning **Statement 1029**—Blank Faceplates and Cover Panels

Blank faceplates and cover panels serve three important functions: they prevent exposure to hazardous voltages and currents inside the chassis; they contain electromagnetic interference (EMI) that might disrupt other equipment; and they direct the flow of cooling air through the chassis. Do not operate the system unless all cards, faceplates, front covers, and rear covers are in place.



Warning **Statement 1034**—Backplane Voltage

Hazardous voltage or energy is present on the backplane when the system is operating. Use caution when servicing.



Warning **Statement 1051**—Laser Radiation

Invisible laser radiation may be emitted from disconnected fibers or connectors. Do not stare into beams or view directly with optical instruments.

Before you begin

- Wear an electrostatic discharge (ESD) wrist strap or other ESD protective device while handling modules.
- Prepare an antistatic surface or packing materials for each module that you remove from the chassis.

Step 1 Open the packaging for the new line card and inspect the module for damage.

If the module is damaged, contact the Technical Assistance Center (TAC).

Step 2 If you are installing the module in an empty slot, remove the blank module that is already in that slot. Unscrew its two captive screws and pull it out of the slot. Go to Step 4.

Step 3 If you are replacing a module that is currently in the chassis, remove the existing module from the chassis by following these steps:

- a) Disconnect and label each of the interface cables from the module.
- b) Push and hold the release button on both ejector levers and then rotate both levers 45 degrees from the module as shown in the following figure.

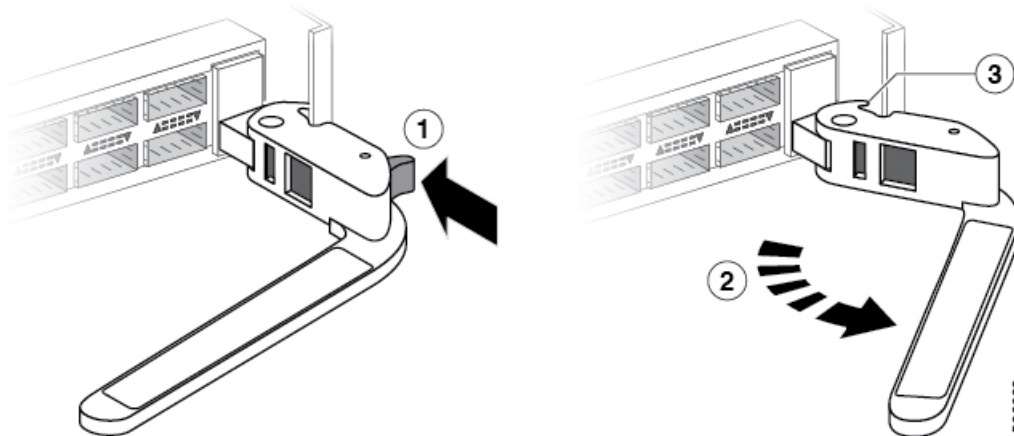

1	Fully press and hold the release button on each ejector lever.	3	When the lever is fully rotated away from the module, the knob at the other end of the lever can no longer hold the module in the slot.
2	Fully rotate both ejector levers away from the module.		

Caution To prevent damage to the ejector lever, you must press and hold the release button on each ejector lever before rotating the lever 45 degrees from the module.

- c) Pull both levers to slide the line card out of its slot in the chassis as shown in the following figure.

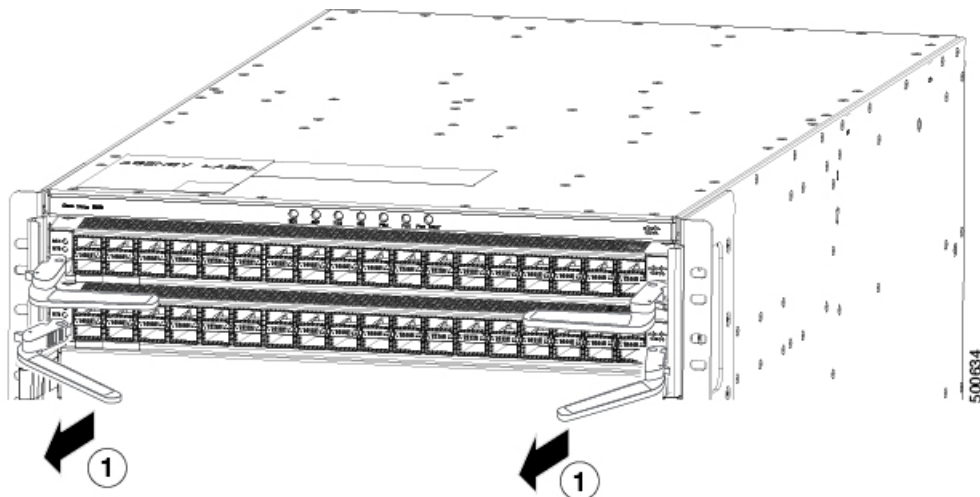

1	Pull both levers to remove the line card from the chassis.		
---	--	--	--

- d) Use one hand to hold the front of the line card, place your other hand under the line card to support its weight. Pull the line card out of the chassis, and set it on an antistatic surface or inside an antistatic bag.

Step 4 To install the new line card, follow these steps:

- a) Press and hold the release button on both ejector levers. Rotate the end of each lever away from the chassis as shown in the following figure.

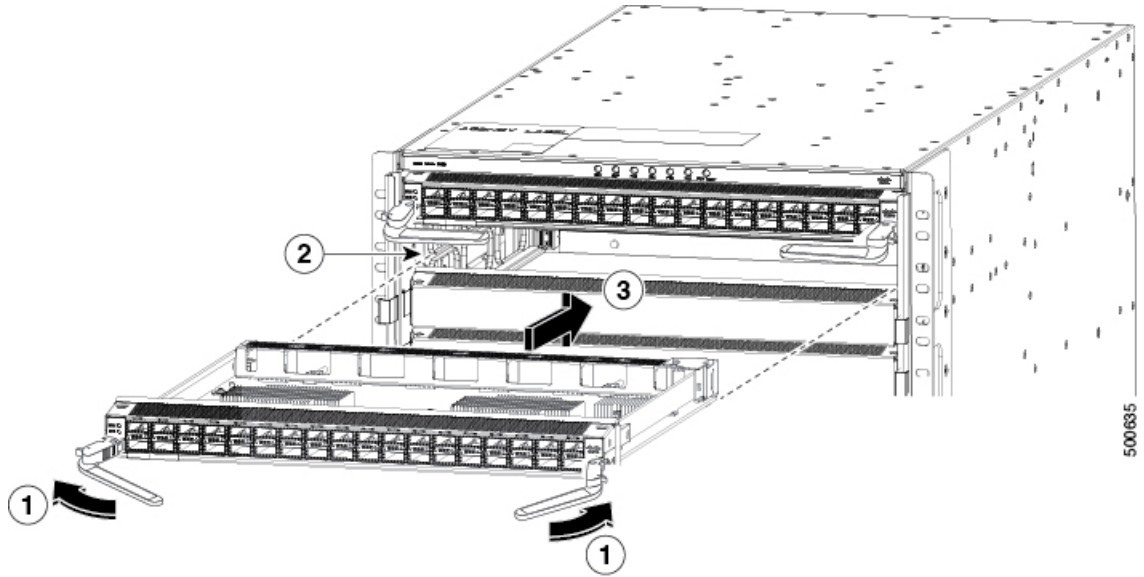

1	Press the release button on each lever and rotate the lever away from the line card.	3	Gently push the line card into the slot until it stops with the front of the line card nearly at the front of the chassis.
2	Align the back of the module to the open slot with the bottom of the line card sliding into guides on each side of the slot.		

- b) Hold the front of the line card with one hand and place your other hand under the line card to support its weight.
- c) Align the back of the line card to the guides in the open line card slot. Gently slide the module into the slot until it stops.

The line card stops when its front is about 0.25 inches (0.6 cm) outside the front of the chassis.

- d) Rotate the ends of the two levers toward the front of the chassis until the levers click and they secure the line card to the chassis.

As you rotate the levers, the line card seats itself onto the fabric modules inside the chassis. And the front of the line card moves all the way to the front of the chassis.

- e) Attach each interface cable to the appropriate port on the line card. Use the label on each cable to determine which port each cable attaches to.
- f) Verify that the line card LEDs turn on and appear as follows:
 - The Status (STS or STA) LED turns on and becomes green.

- For each connected port, the port LED turns on and becomes green or amber.

Replacing a Fan Tray

You can remove a fan tray to either replace it with another fan tray or to replace a fabric module that is located behind it.

The switch uses three fan trays. It can operate with two fan trays while you replace one or remove one to replace one of the fabric modules behind the fan tray. When you remove one fan tray, the other fan trays speed up their fans to maintain the designed airflow.



Note If you cannot replace a fan tray within three minutes, we recommend that you leave it in the chassis until you are ready to replace it.



Note If you remove more than one fan tray at a time during operations, the switch allows up to two minutes of operations before shutting down. If the switch senses an overtemperature condition when multiple fan trays are removed, the shutdown can occur in less than two minutes.



Warning **Statement 1034**—Backplane Voltage

Hazardous voltage or energy is present on the backplane when the system is operating. Use caution when servicing.

Removing a Fan Tray

Remove only one fan tray at a time during switch operations. The switch shuts down within two minutes.

Before you begin

- Wear an electrostatic discharge (ESD) wrist strap or other ESD protective device while handling modules.
- Prepare an antistatic surface or packing materials for each module that you remove from the chassis.

Step 1 Open the packaging for the new fan tray and inspect it for damage.

If the module is damaged, contact the Technical Assistance Center (TAC) and wait until you have an undamaged fan tray to install.

Step 2 Unscrew the four captive screws on the front of the fan tray until each screw is free of the chassis. See the following figure.

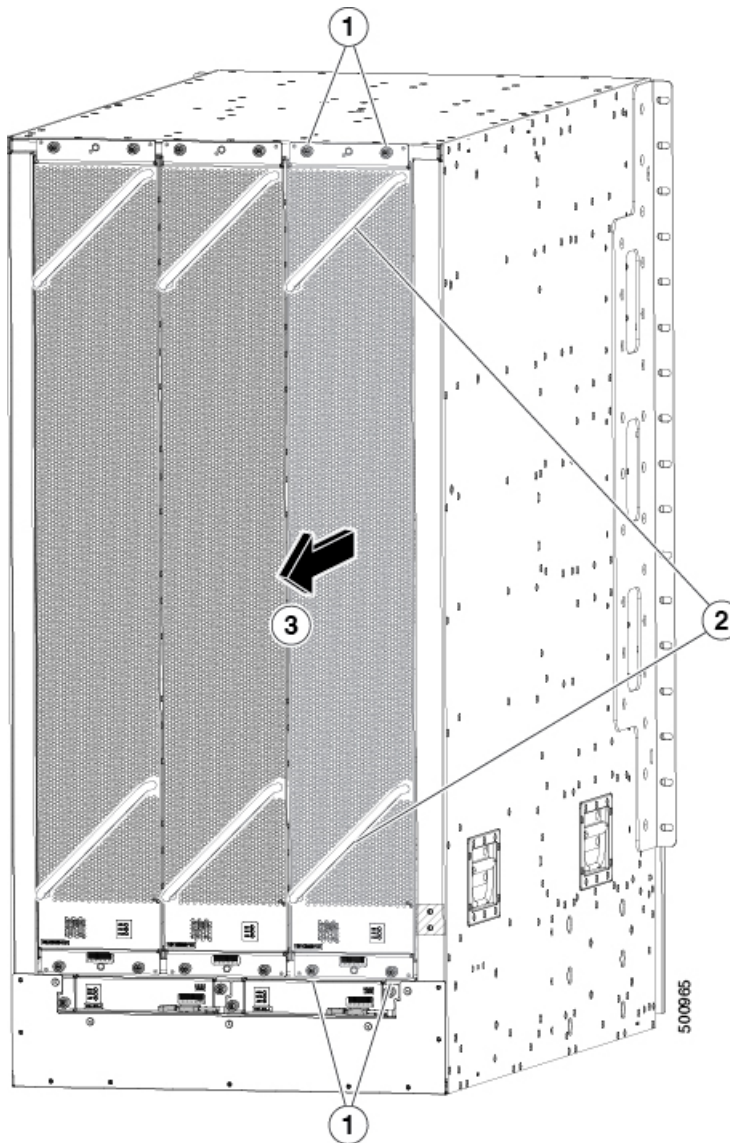

1	Unscrew 4 captive screws (2 at the top of the module and 2 at the bottom of the module).	3	Pull on the fan tray to slide it out of the chassis. Set the fan tray on an antistatic surface.
2	Hold the 2 fan tray handles with both hands.		

Step 3 Hold both handles on the front of the fan tray with both of your hands and pull the fan tray out of the slot.

Step 4 Set the fan tray on antistatic material or inside an antistatic bag.

Installing a Fan Tray

Before you begin

- Fan tray slot is open in the chassis.
- Fan tray is available for installation.
- If you are replacing a fabric module behind the open fan tray slot, that replacement operation is completed.

Step 1 Use both of your hands to hold the two handles on the front of the fan tray that you are installing.

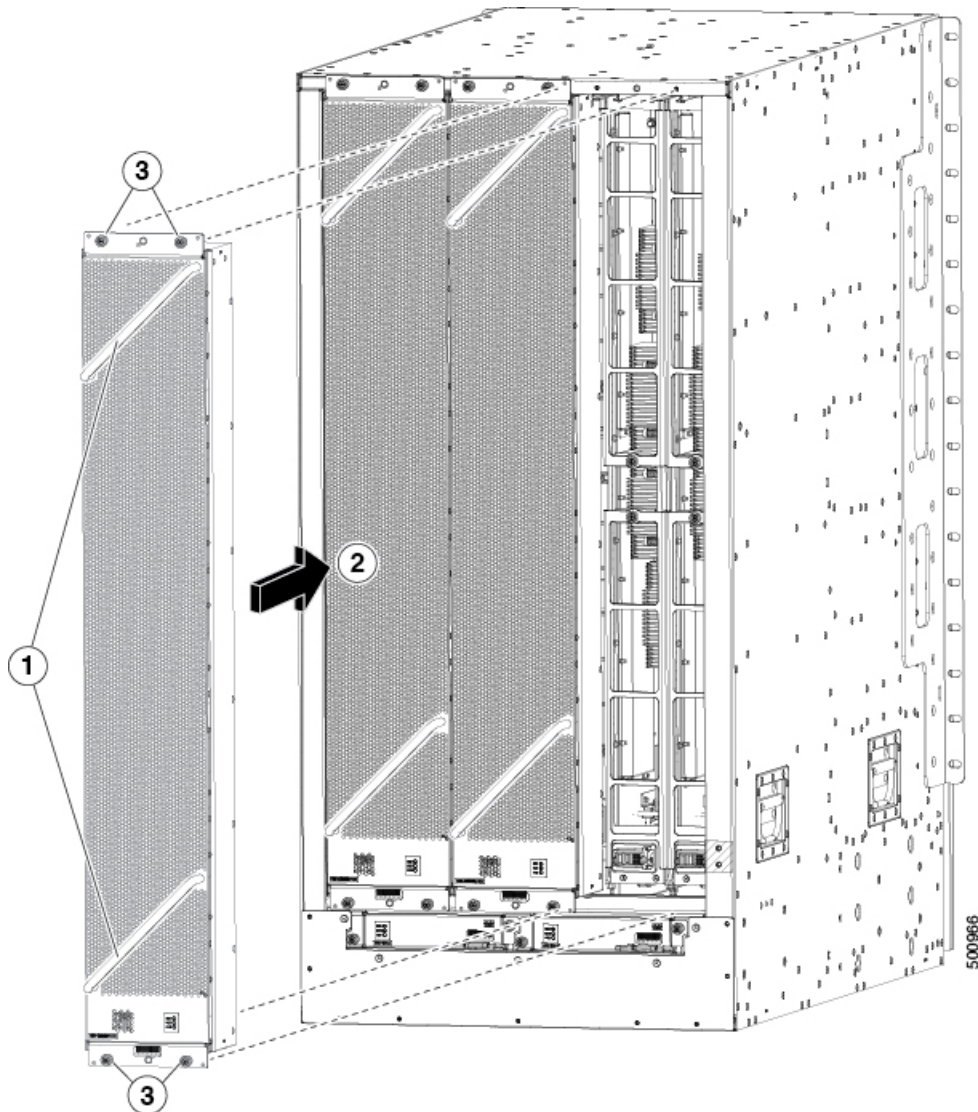

1	Hold the 2 fan tray handles with both hands.	3	Screw in 4 captive screws and tighten each screw to 8 in-lb (0.9 N·m) of torque.
---	--	---	--

2	Position the back of the fan tray to the open fan tray slot. The pins on the top and bottom of the fan tray align to holes in the chassis. The 2 sets of rails on the top of the fan tray align to 2 sets of tracks on the top of the open slot. Slide the fan tray all the way into the slot.		
---	--	--	--

- Step 2** Position the fan tray with its rear (the side with the electrical connectors) at the opening for the fan tray slot in the chassis.
- Step 3** Align the two tracks on the top of the fan tray with the two sets of rails at the top of the open fan tray slot in the chassis.
- Step 4** Slide the fan tray all the way into the slot until the front of the fan tray touches the chassis.
Make sure that the four captive screws on the front of the fan tray align with the four screw holes in the chassis.
- Step 5** Screw in the four captive screws to secure the fan tray to the chassis. Tighten the screws to 8 in-lb (0.9 N·m) of torque.
- Step 6** Verify that the fan tray STATUS LED turns on and becomes green.

Replacing a Fabric Module

The switch uses three to six fabric modules depending on the requirements of the line cards that are installed in the chassis.



- Note** If you are downgrading the operating system, you must ensure both of the following:
- The new version of software supports the fabric modules and line cards, which are installed in the same switch.
 - The fabric modules that are installed in the switch, support the line cards that are installed in the same switch.

The fabric modules must be installed in specific slots as follows (installing fabric modules in other slots can cause a module mismatch condition):

- For three modules, they must be in slots FM 2, FM 4, and FM 6.
- For four modules, they must be in slots FM2, FM 3, FM 4, and FM 6.
- For five modules, they must be in Slots FM 2, FM 3, FM 4, FM 5, and FM 6.
- For six modules, they are in slots FM 1, FM 2, FM 3, FM 4, FM 5, and FM 6

You can replace a fabric module while other fabric modules are operating by removing the fan tray in front of the fabric module. Remove the fabric module, then install the new fabric module, and replace the fan tray over the installed fabric module.

To maintain the designed airflow while you remove the fan tray, the fans in the other fan trays increase their speed. During operations, we recommend that you remove only one fan tray at a time and reinstall that fan tray within three minutes. This action avoids the possibility of having the switch overheat and shut down.

**Caution**

If you remove more than one fan tray at a time, the switch shuts down if you do not reinstall the extra missing fan trays within two minutes. The shutdown can occur earlier if the switch over heats.

Removing a Fabric Module

Before you begin

- Wear an electrostatic discharge (ESD) wrist strap or other ESD protective device while handling modules.
- Prepare an antistatic surface or packing materials for each module that you remove from the chassis.
- Remove the fan tray that covers the fabric module that you are removing.

Step 1 If you are replacing a fabric module, open the packaging for the new module and inspect it for damage.

If the module is damaged, alert the Technical Assistance Center (TAC) and stop this replacement process until you have an undamaged module to install.

Step 2 Remove the fan tray that covers the fabric module by following these steps:

- a) Unscrew the four captive screws on the front of the fan tray until each screw is free of the chassis. See Callout 1 in the following figure.

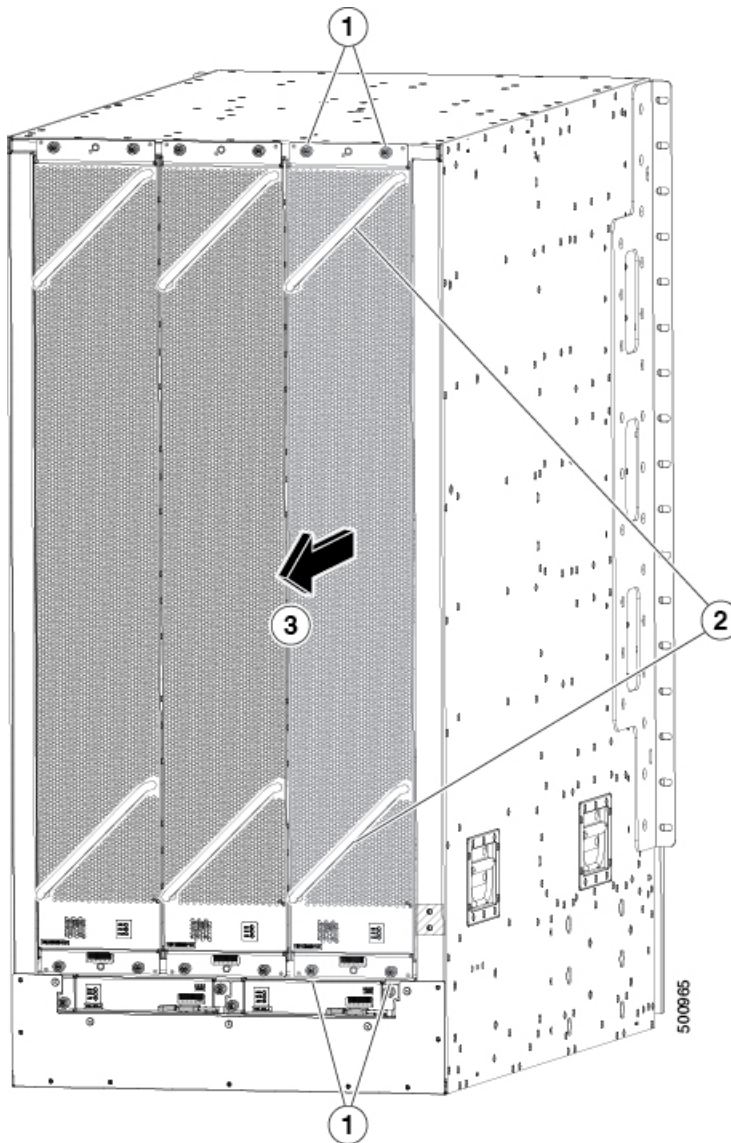

1	Unscrew 4 captive screws (2 at the top of the module and 2 at the bottom of the module).	3	Pull on the fan tray to slide it out of the chassis. Set the fan tray on an antistatic surface.
2	Hold the 2 fan tray handles with both hands.		

- b) Hold both handles on the front of the fan tray with both of your hands and pull the fan tray out of the slot.
- c) Set the fan tray on antistatic material or inside an antistatic bag.

Step 3 To prevent a loss of packets during operations, shut down the fabric module as follows:

Step 4 Remove the fabric module that you are replacing by following these steps:

- a) Unscrew the screw on the center of each of the two handles on the fabric module. See Callout 1 in the following figure.

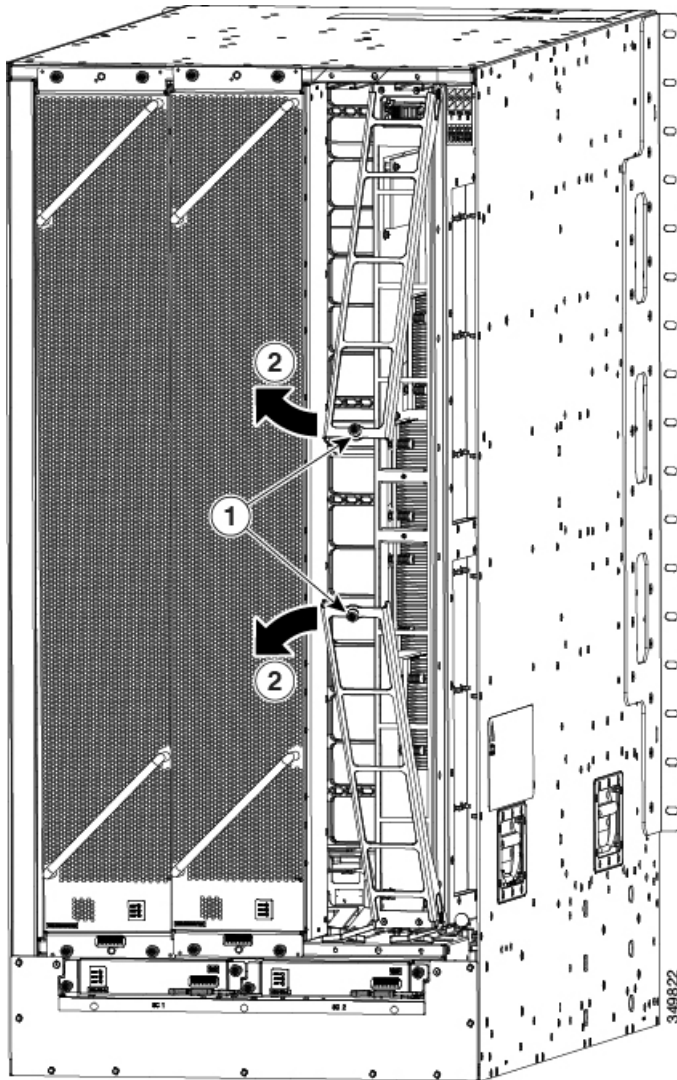

1	Unscrew 2 captive screws (1 on each ejector handle).	2	Rotate both ejector handles away from the front of the fabric module.
---	--	---	---

- b) Rotate the two handles at least 30 degrees so that the other end of each handle no longer holds the module in the slot. See Callout 2 in the previous figure.
- c) With each of the two handles in your two hands, pull the module a couple of inches (about 5 cm) out of the slot. See the following figure.

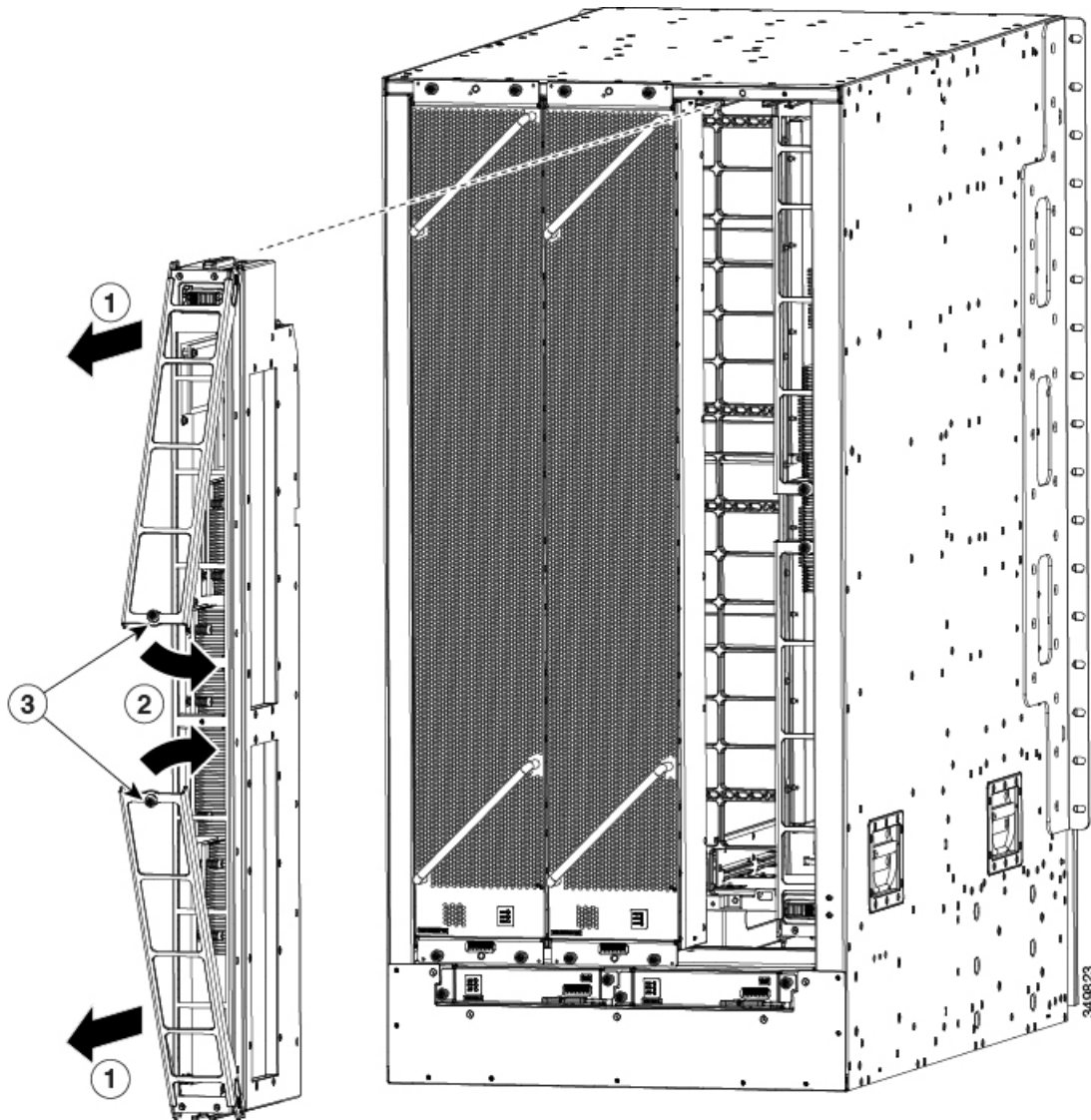

1	Pull on both handles to remove the fabric module from the chassis.	3	Screw in the 2 captive screws (1 on each handle) to the module. Tighten each of these screws to 8 in-lb (0.9 N·m) of torque.
2	Rotate both ejector handles to the front of the module.		

- d) Rotate both handles back to the front of the module until they click in place. Fasten each handle to the module using the captive screw on the back of the handle. Tighten the screw to 8 in-lb (0.9 N·m) of torque. See Callouts 2 and 3 in the previous figure.
- e) Place one hand under the fabric module to support its weight. Place your other hand on the front of the module, and slide the module out of the slot.
- f) Rotate the module 90 degrees and lay it flat on an antistatic surface or in an antistatic bag.

Installing a Fabric Module

Before you begin

- Wear an electrostatic discharge (ESD) wrist strap or other ESD protective device while handling modules.
- Prepare an antistatic surface or packing materials for each module that you remove from the chassis.
- Be sure that you are replacing a fabric module with the same type of fabric module. All the fabric modules that are installed in the switch must be the same type.

Step 1 Place one hand on the front of the module and turn the module 90 degrees so that the electrical connectors are on the bottom.

Step 2 Unscrew the two captive screws (one on each ejector handle) and rotate the ejector handles away from the chassis. See Callouts 1 and 2 in the following figure. Be sure that the locking posts on the top and bottom of the chassis rotate into the module so that the module can slide fully into the slot. See Callout 3 of the following figure.

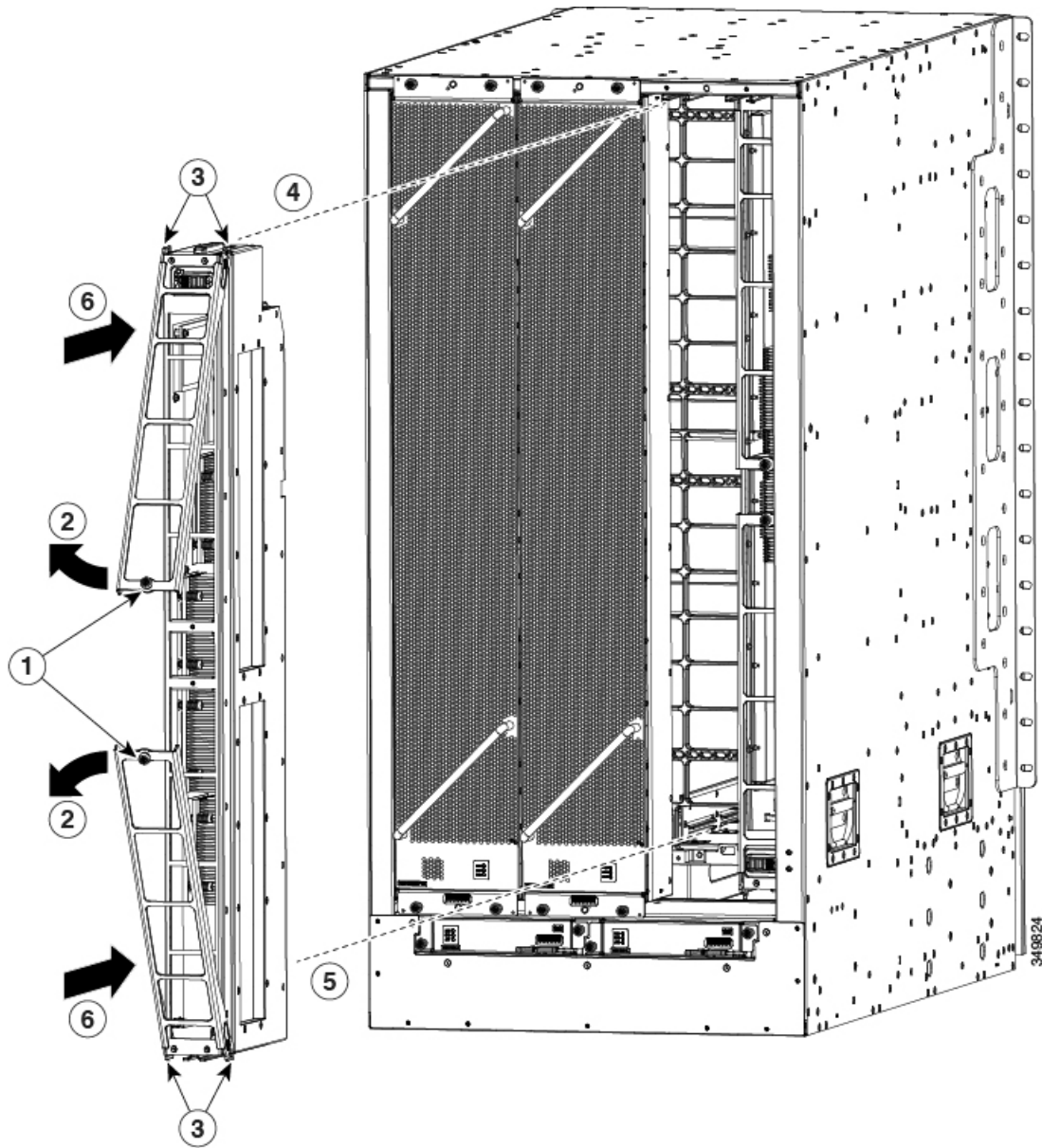

1	Unscrew 2 captive screws (1 on each ejector handle).	4	Align the rails on the top of the module to the track on the top of the open slot.
2	Rotate both ejector handles away from the front of the module.	5	Align the bottom of the module so that it slides into the tracks on the bottom of the open slot.
3	Be sure that the locking posts fully rotate down into the module.	6	Slide the module all the way into the slot.

Step 3 Fit the guide rails on the top of the module into the track on the top of the slot. Make sure that the guide bar on the bottom of the module goes into the module guide at the bottom of the slot.

Be sure that you are installing the fabric module in a supported fabric module slot. The supported fabric module slots differ depending on the number of fabric modules that are installed in the switch as follows:

- For three modules, they must be in slots FM 2, FM 4, and FM 6
- For four modules, they must be in slots FM2, FM 3, FM 4, and FM 6
- For five modules, they must be in Slots FM 2, FM 3, FM 4, FM 5, and FM 6.
- For six modules, they are in slots FM 1, FM 2, FM 3, FM 4, FM 5, and FM 6

Step 4 Slide the module all the way into the slot.

Step 5 Rotate both ejector levers to the front of the chassis and be sure that the module is locked to the top and bottom of the slot.

Step 6 Screw in the captive screw on each of the two levers so that each lever is locked in place on the module. Tighten each screw to 8 in-lb (0.9 N·m) of torque.

Step 7 Power up the fabric module as follows:

a) On the menu bar of the APIC GUI, choose FABRIC > INVENTORY.

Note If you have already navigated to the fabric module, go to step 7c.

b) In the Navigation pane, navigate to the fabric module as follows:

1. Expand the appropriate Pod.
2. Expand the appropriate spine.
3. Expand Chassis.
4. Expand Fabric Modules.
5. Choose the appropriate fabric slot.

c) On the upper right corner of the Properties screen, choose Actions > Enable.

d) Verify that the Fabric LED for the slot that you specified turns on.

Step 8 Reinstall the fan module over the replaced fabric module by following these steps:

a) Use both of your hands to hold the two handles on the front of the fan tray that you are installing.

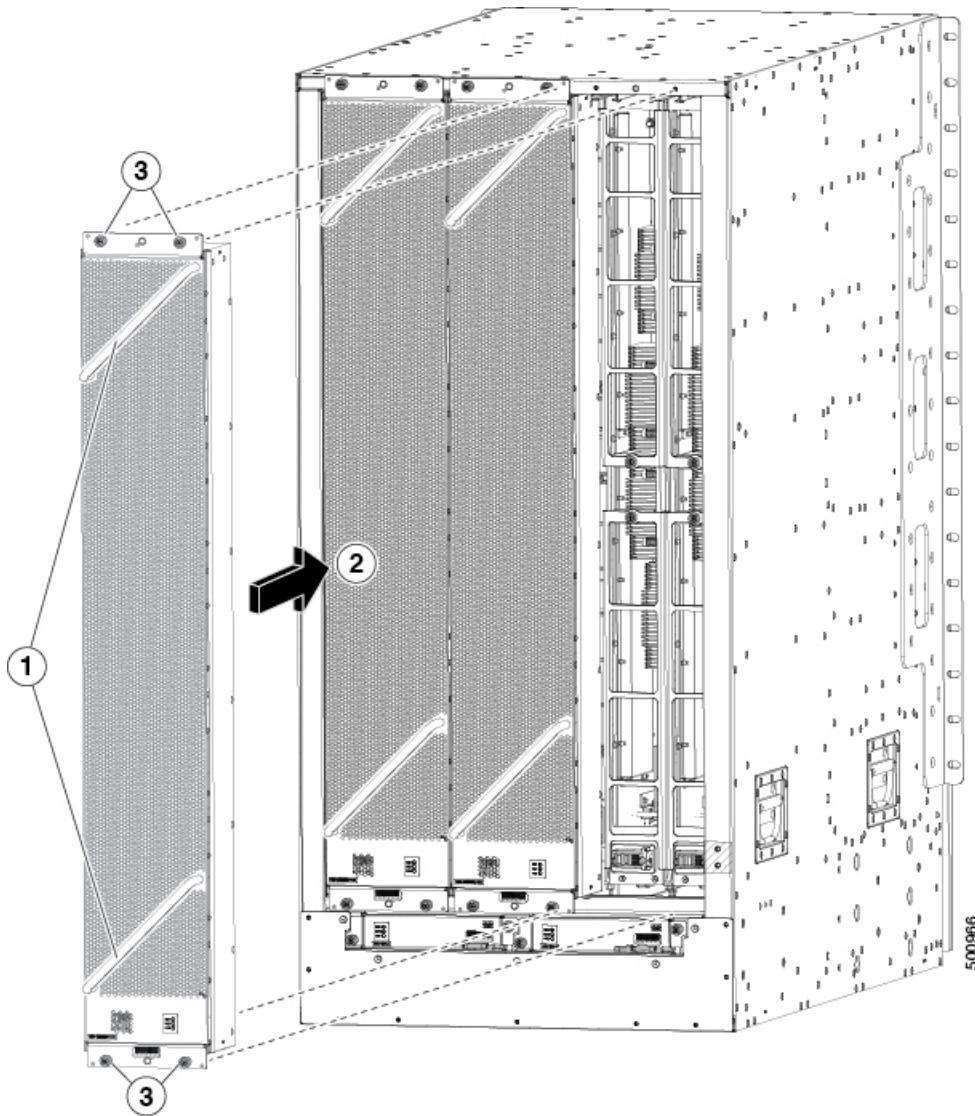

1	Hold the 2 fan tray handles with both hands.	3	Screw in 4 captive screws and tighten each screw to 8 in-lb (0.9 N·m) of torque.
2	Position the back of the fan tray to the open fan tray slot. The pins on the top and bottom of the fan tray align to holes in the chassis. The 2 sets of rails on the top of the fan tray align to 2 sets of tracks on the top of the open slot. Slide the fan tray all the way into the slot.		

- b) Position the fan tray with its rear (the side with the electrical connectors) at the opening for the fan tray slot in the chassis.
- c) Align the two tracks on the top of the fan tray with the two sets of rails at the top of the open fan tray slot in the chassis.
- d) Slide the fan tray all the way into the slot until the front of the fan tray touches the chassis.

Make sure that the four captive screws on the front of the fan tray align with the four screw holes in the chassis.

- e) Screw in the four captive screws to secure the fan tray to the chassis. Tighten the screws to 8 in-lb (0.9 N·m) of torque.
- f) Verify that the fan tray and fabric module STATUS LEDs (on the fan tray) turn on and become green.

Installing or Replacing Power Supplies

The number of 3-kW and 3.15-kW power supplies that you install depends on the power requirements of the switch. It also depends on the power mode that you are using. To determine the power requirements of the switch, see the [Power Requirements](#) section.

If you are using only one power source for the combined mode or $n+1$ redundancy mode, you can install the power supplies in any of the power supply slots on the chassis. If you are using two power sources for the $n+n$ redundancy mode, you must connect the power supplies in to one power source and the power supplies in slots 6 through 10 to the other power source. With $n+n$ redundancy mode, divide the power supplies evenly between the first half of the slots and the last half of the slots. The amount of redundant power for the switch equals the amount of available power for the switch.



Warning Statement 1034—Backplane Voltage

Hazardous voltage or energy is present on the backplane when the system is operating. Use caution when servicing.



Warning Statement 1029—Blank Faceplates and Cover Panels

Blank faceplates and cover panels serve three important functions: they prevent exposure to hazardous voltages and currents inside the chassis; they contain electromagnetic interference (EMI) that might disrupt other equipment; and they direct the flow of cooling air through the chassis. Do not operate the system unless all cards, faceplates, front covers, and rear covers are in place.

You can install or replace any of the following Cisco Nexus 9500 Series power supplies in this switch:

- 3-kW AC Power Supply
- 3-kW Universal AC/DC Power Supply
- 3.15-kW Dual Input Universal AC/DC Power Supply
- 3-kW DC Power Supply

Installing or Replacing a 3-kW AC Power Supply

Before you begin

- The AC power source must be installed within reach of the power cables.
- The AC power source meets the power specifications that the switch requires.

- There are one or two AC power sources available. If using $n+n$ redundancy, there must be two power sources available. Otherwise, only one power source is required.

Step 1 Open the packaging for the new 3-kW AC power supply and inspect the module for damage.

If the module is damaged, contact the Technical Assistance Center (TAC).

Step 2 If you are installing the module in an empty slot, remove the blank filler plate that is already in that slot. Unscrew its captive screws and pull it out of the slot. If you are using the combined power mode or $n+1$ redundancy, you can use any power supply slot in the chassis. If you are using $n+n$ redundancy mode, you must be sure that you are inserting the power supply in a slot that is used for the desired power supply (the power supplies in slots 1 through 5 must be connected to one power source and the power supplies in slots 6 through 10 must be connected to the other power source). Go to Step 4.

Step 3 If you are replacing a power supply that is currently in the chassis, remove the existing module from the chassis by following these steps:

- Disconnect the power cable from the power supply and verify that the output and input LEDs turn off.
- Slide the middle of the ejector lever down to the end of the lever and rotate the lever up so that its other end no longer holds onto the chassis. See the following figure.

The power supply unlocks from the chassis and moves out slightly.

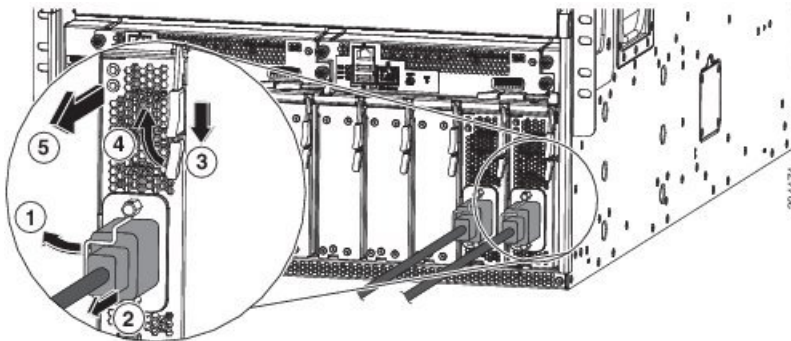

1	Rotate the cable retention clip away from the power cable plug.	4	Rotate the ejector lever away from the module.
2	Pull the power cable plug out of the receptacle.	5	Pull on the ejector lever to slide the power supply partially (2 inches [5 cm]) out of the chassis. Hold the front of the power supply and pull it all the way out of the chassis.
3	Slide and hold the middle handle on the ejector lever toward the end of the lever.		

- Pull on the lever to move the power supply about 2 inches (5 cm) out of the slot.
- Place one hand on the front of the power supply and your other hand under the power supply to support its weight.
- Pull the module out of the slot and place it on an antistatic surface or inside an antistatic bag.

Step 4 To install the new power supply, follow these steps:

- Ensure that the power supply is not connected to an AC power source. If it is connected to a power source, remove the power cable from the power supply and wait at least five seconds before doing the next step.

- b) Hold the front of the module with one hand and place your other hand under the module to support its weight.
- c) Rotate the power supply 90 degrees so that the power receptacle is positioned on the lower front side. That way the back of the power supply is oriented to slide into the open power supply slot.
- d) Slide the guide bracket that is located on the top of the power supply into the track at the top of the power supply slot. Slide the power supply all the way into the slot.

The front of the power supply is about 0.25 inches (0.6 cm) outside the chassis.

- e) Slide the handle on the middle of the power supply ejector handle about 0.25 inches (0.6 cm) and rotate the lever away from the front of the power supply. Do this while pushing the power supply all the way into the chassis. See the following figure.

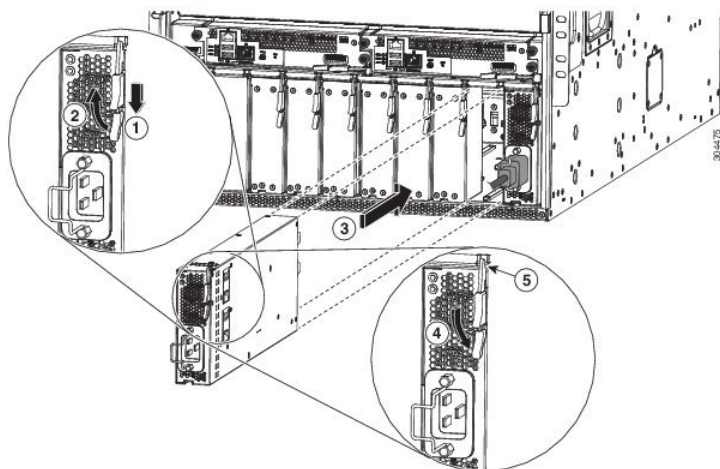

1	Slide and hold the middle handle on the ejector lever toward the end of the lever.	4	Rotate the lever toward the front of the module.
2	Fully rotate the release lever away from the front of the module.	5	Make sure that the other end of the lever grabs the front of the chassis to push the module onto the connectors inside the slot.
3	Slide the power supply into the open power supply slot in the chassis until it stops. The front of the module is about 0.25 inches (0.6 cm) in front of the chassis.		

- f) Rotate the ejector lever toward the front of the power supply and be sure that the other end of the lever locks into the chassis.
The lever will click when you rotate it all the way to the front of the power supply. Be sure that the power supply is fully inserted into the slot. The front of the power supply will be even with the surface of the chassis.
- g) Attach the power cable to the power receptacle on the power supply and rotate the power cable holder onto the plug on the cable.
- h) Make sure that the other end of the power cable is attached to the AC power source in one of the following ways:
 - If you are using the combined power mode or the $n+1$ redundancy mode, you must connect the power cable to the same power source as used by the other power supplies in the same switch.
 - If you are using the $n+n$ redundancy mode, you must connect the power cable to the same power source as used by the other power supplies in the same set of power supply slots in the chassis. The power cables for slots 1

through 5 must be connected to one power source and the power cables in slots 6 through 10 must be connected to another power source.

- i) Verify that the OK LED turns on and eventually becomes green.

Installing or Replacing a 3-kW Universal AC/DC Power Supply

Before you begin

- The power source must be installed within reach of the power cables.
- The power source must meet the power specifications that the switch requires.
- There are one or two power sources available. If using $n+n$ redundancy, there must be two power sources available. Otherwise, only one power source is required.

Step 1 Open the packaging for the new 3-kW Universal AC/DC power supply and inspect the module for damage.

If the module is damaged, contact the Technical Assistance Center (TAC).

Step 2 If you are installing the module in an empty slot, remove the blank filler plate that is already in that slot. Unscrew its captive screw and pull it out of the slot. If you are using the combined power mode or $n+1$ redundancy, you can use any power supply slot in the chassis. If you are using $n+n$ redundancy mode, you must be sure that you are inserting the power supply in a slot that is used for the desired power supply (the power supplies in slots 1 through 5 must be connected to one power source and the power supplies in slots 6 through 10 must be connected to the other power source). Go to Step 4.

Step 3 If you are replacing a power supply that is currently in the chassis, remove the existing module from the chassis by following these steps:

a) Turn off the power to the power supply that you are replacing as follows:

1. Shut off the power supply by setting its power switch to 0.
2. If the power supply is connected to a DC circuit, shut off the circuit at the circuit breaker.
3. Verify that the OK LED has turned off (indicates that there is no power going to the power supply).

Note If the FAULT LED is on and the color is amber, that indicates that the power source connection has been broken.

4. Remove the power cable plug from the power supply receptacle.

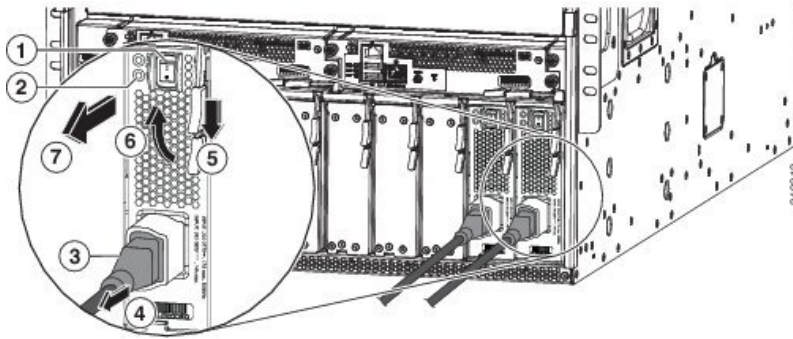

1	Turn off the power supply (and circuit breaker for a DC circuit).	4	Rotate the release lever toward the front of the power supply.
2	Verify that the OK LED turns off.	6	Rotate the release lever away from the power supply.
3	Press and hold the release button on the plug.	7	Pull the power supply out of the chassis.
4	Pull the power cable plug out of the power supply receptacle.		

- b) Slide the middle of the ejector lever down to the end of the lever and rotate the lever away from the chassis. The power supply unlocks from the chassis and moves out slightly.
- c) Pull on the lever to move the power supply about 2 inches (5 cm) out of the slot.
- d) Place one hand on the front of the power supply and your other hand under the power supply to support its weight.
- e) Pull the module out of the slot and place it on an antistatic surface or inside an antistatic bag.

Step 4 To install the new power supply, follow these steps:

- a) If you are using a DC power source, ensure that the circuit is turned off at the circuit breaker.
- b) Hold the front of the power supply module with one hand and place your other hand under the module to support its weight.
- c) Rotate the power supply 90 degrees so that the power receptacle is positioned on the lower front side. And so that the back of the power supply is oriented to slide into the open power supply slot.
- d) Slide the guide bracket that is located on the top of the power supply into the track at the top of the power supply slot. Slide the power supply into the slot until the front of the module stops about 0.25 inches (0.6 cm) in front of the module.
- e) Slide the handle on the middle of the power supply release lever toward the end of the module and rotate the lever away from the front of the power supply while pushing the power supply all the way into the chassis. See the following figure.

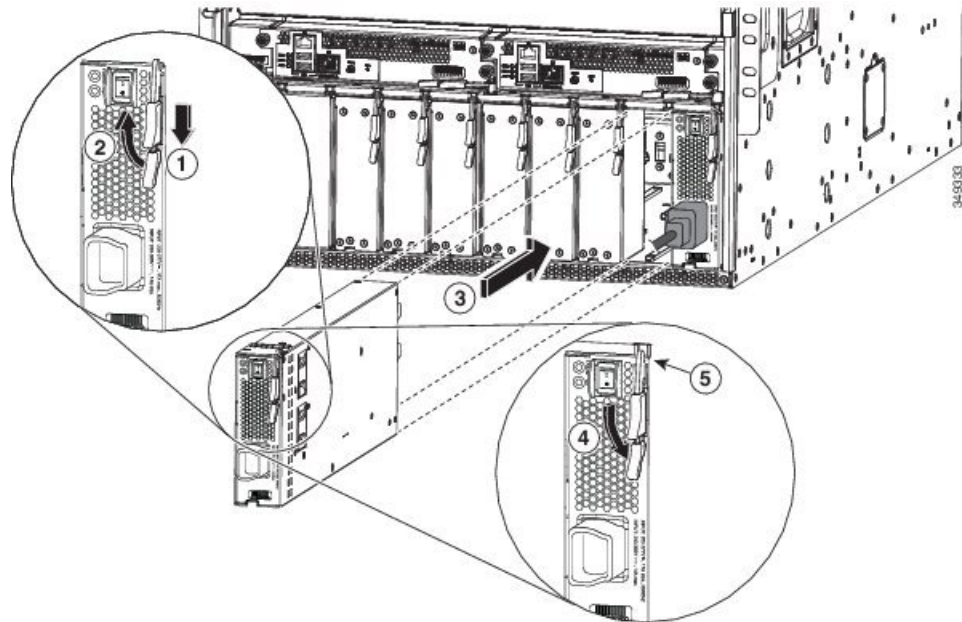

1	Slide and hold the middle handle next to the outer handle.	4	Rotate the lever toward the front of the module.
2	Fully rotate the release lever away from the front of the module.	5	Make sure that the other end of the lever grabs the front of the chassis to push the module onto the connectors inside the slot.
3	Slide the power supply into the open power supply slot in the chassis until it stops. The front of the module is about 0.25 inches (0.6 cm) in front of the chassis.		

- f) Carefully rotate the ejector lever toward the front of the power supply and be sure that the other end of the lever grabs the chassis. This pushes the module onto its connectors inside the slot.
The lever will click when you rotate it all the way to the front of the power supply. Be sure that the power supply is fully inserted into the slot. The front of the power supply will be even with the surface of the chassis.
- g) Attach the power cable to the power receptacle on the power supply.
- h) Make sure that the other end of the power cable is attached to the power source in one of the following ways:
 - If you are using the combined power mode or the $n+1$ redundancy mode, you can connect the power cable to the same power source as used by the other power supplies in the same switch.
 - If you are using the $n+n$ redundancy mode, you must connect the power cable to the same power source as used by the other power supplies in the same set of power supply slots in the chassis. The power cables for slots 1 through 5 must be connected to one power source and the power cables in slots 6 through 10 must be connected to another power source.
- i) If you connected the power supply to a DC power source do the following:
 1. Turn on the circuit breaker for the DC power source.
 2. Turn on the power supply by setting the power switch to on (1).

- j) Verify that the OK LED turns on and eventually becomes green.

Installing or Replacing a 3.15-kW Dual Input Universal AC/DC Power Supply

The HVAC/HVDC power supply (N9K-PUV2-3000W-B) has two redundant input power lines. It can provide power output at 3.15KW with either one or two input power lines operating. The HVAC/HVDC power supply provides n+n or n+x line redundancy mode in a single power supply for the Cisco Nexus 9500 Series switches.

The HVAC/HVDC power supply accepts 200–240VAC or 240/380VDC input power.

If you are not using power redundancy or are using $n+1$ power redundancy, you can connect all the power supplies in the chassis to the same power grid. If you are using $n+n$ power redundancy, connect one set of the power supply inputs to one power grid and the other set of the power supply inputs to another power grid. For example, connect grid A to the receptacles closest to the power switch on the power supplies, and connect grid B to the receptacles furthest from the power switch on the power supplies.



Note You can have a mix of AC power supplies and HVAC/HVDC power supplies in a chassis.

Before you begin

- The AC or DC power source must be turned off at its circuit breaker.
- The power switch on the power supply must be turned off (power switch set to 0).
- The AC power sources are rated as follows:
 - For North American installations—20A with 200-240V circuits.
 - For international installations—size the circuits by local and national standards.

Step 1 Open the packaging for the new 3-kW Universal AC/DC power supply and inspect the module for damage.

If the module is damaged, contact the Technical Assistance Center (TAC).

Step 2 For AC input, connect an AC power cable to the AC power source.

Step 3 For DC input, connect a Saf-D-Grid/Saf-D-Grid DC cable to a Saf-D-Grid receptacle, otherwise:

- a) Connect the ground terminal ring on the power cable to the ground terminal on the DC power source. Secure it in place with a nut tightened to the appropriate torque setting for the terminal post.
- b) Connect the negative terminal ring on the power cable to the negative (-) terminal on the DC power source. Secure it in place with a nut tightened to the appropriate torque setting for the terminal post.
- c) Connect the positive terminal ring on the power cable to the positive (+) terminal on the DC power source. Secure it in place with a nut tightened to the appropriate torque setting for the terminal post.

Step 4 Connect the Saf-D-Grid connector on the other end of the power cable to the Saf-D-Grid receptacle on the power supply.

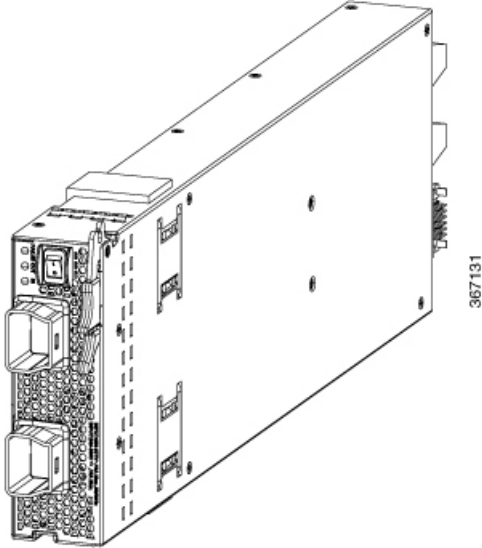

Step 5 Turn on the circuit breaker for the DC power source circuit.

Step 6 Turn on the power supply by pressing its power switch to on.

Step 7 Verify that the OUT LED turns on and becomes green.

Note If you use both inputs, the IN LED is green. If you use only one input, the IN LED is blinking green.

Installing or Replacing a 3-kW DC Power Supply

Before you begin

- The power source must be installed within reach of the power cables.
- The power source must meet the power specifications that the switch requires.
- There are one or two power sources available. If using $n+n$ redundancy, there must be two power sources available. Otherwise, only one power source is required.
- Prepare an antistatic surface or antistatic bag for the power supply that you are removing.

Step 1 Open the packaging for the new 3-kW DC power supply and inspect the module for damage.

If the module is damaged, contact the Technical Assistance Center (TAC).

Step 2 If you are installing the module in an empty slot, remove the blank filler plate that is already in that slot. Do this action by unscrewing its captive screw and pulling it out of the slot.

Step 3 If you are replacing a power supply that is currently in the chassis, remove the existing module from the chassis by following these steps:

- a) Turn off the power to the power supply that you are replacing as follows:

1. Shut off the power supply by setting its power switch to 0.
2. Shut off the power from the power source by turning off the circuit breaker for each of the two input lines to the power supply.

Verify that the LEDs on the power supply turn off.

b) Disconnect the power cables from the power supply as follows:

1. Remove the three screws on the safety cover for the terminal box that is located on the front of the power supply. Then pull the cover off the terminal box as shown in the following figure.

Note The terminal box has four slots for four power terminals (ordered as negative [-], positive [+], positive [+], and negative [-]). Each terminal has two nuts that you use to fasten a power cable to the terminal.

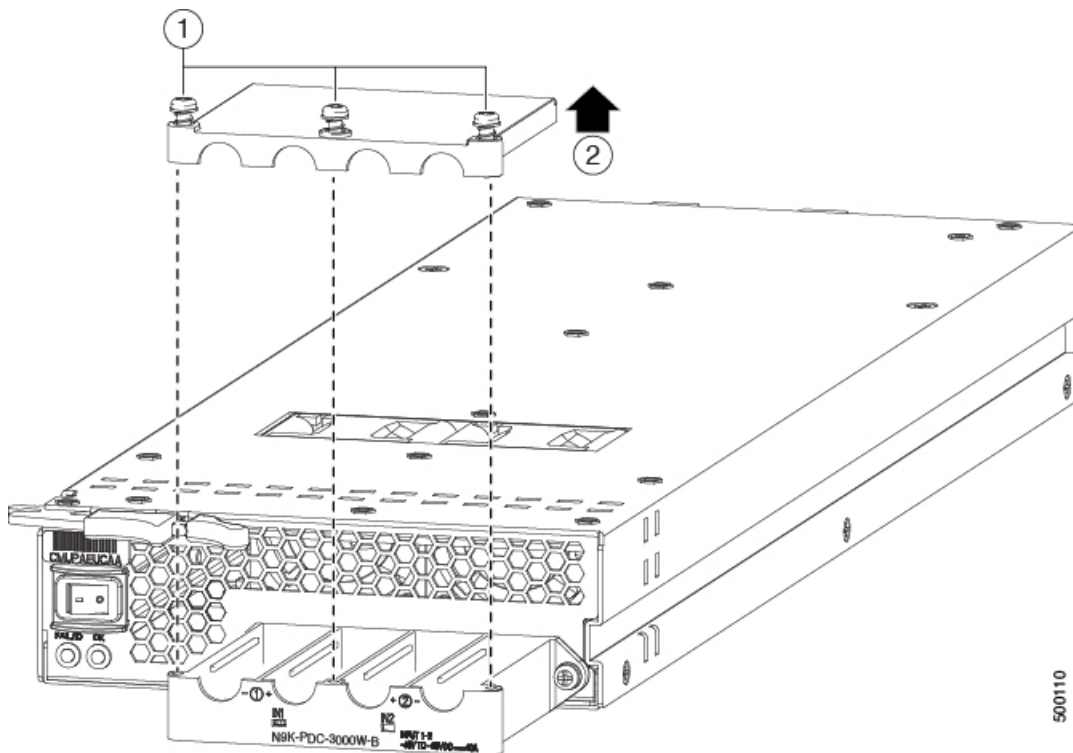

1	Remove 3 screws from the safety cover.	2	Remove the cover.
---	--	---	-------------------

2. Unscrew the two nuts holding each of the four cables to the terminal box. Remove the cables and replace the nuts on the two posts in each of the slots.
3. Replace the safety cover on the terminal box and secure it in place with three screws.

c) Remove the power supply from the chassis as follows:

1. Slide the middle of the ejector lever toward the end of the lever and rotate the lever away from the chassis.

The power supply unlocks from the chassis and moves out slightly.

2. Use one of your hands to hold the front of the power supply and place your other hand under the power supply to support its weight.
3. Pull the module out of the slot and place it on an antistatic surface or inside an antistatic bag.

Step 4 If you are not installing a replacement power supply, cover the empty power supply slot with a blank module.

Step 5 If you are installing a replacement power supply, install, connect, and power up the new power supply as follows:

a) Install the power supply as follows:

1. Hold the front of the power supply with one hand and place your other hand under the module to support its weight.
2. Turn the power supply 90 degrees so that the release lever is on the upper right front end of the module. Position and orient the other end of the module at the open power supply slot in the chassis.
3. Slide the handle on the middle of the release lever toward the end of the lever and rotate the lever away from the front of the power supply. Push the power supply all the way into the slot. See the following figure.

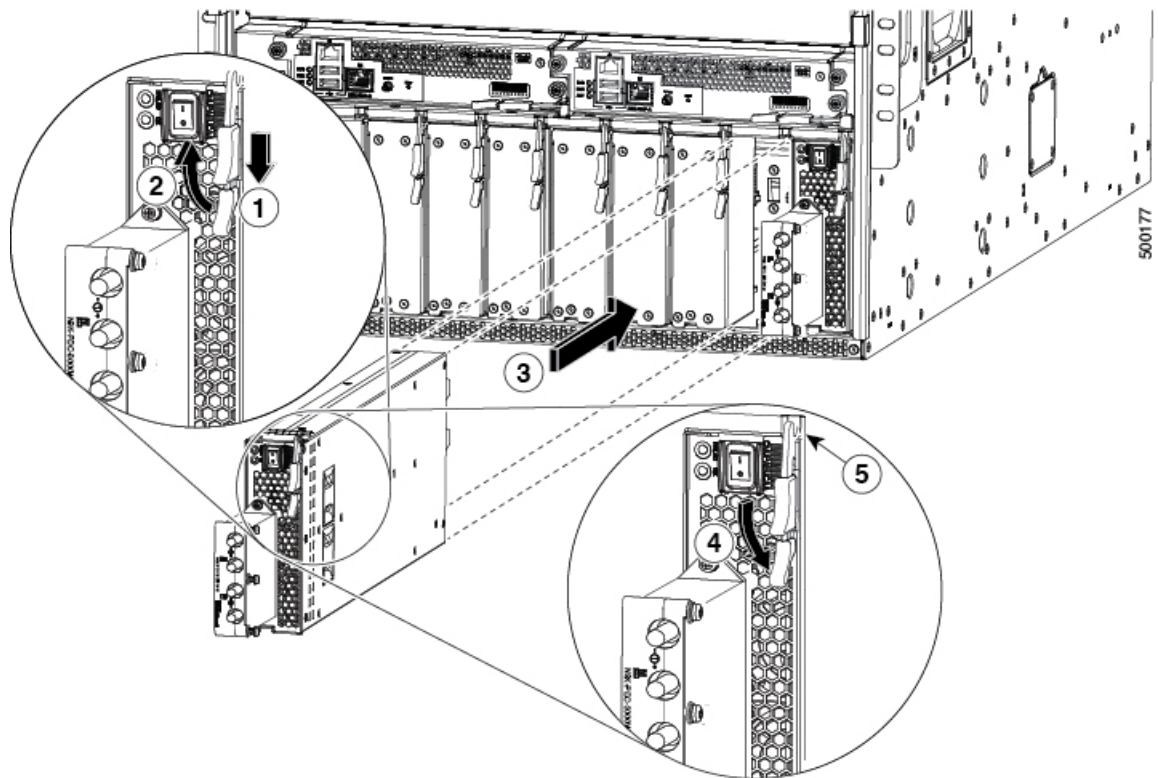

1	Slide and hold the middle handle next to the outer handle.	4	Rotate the lever toward the front of the module.
2	Fully rotate the release lever away from the front of the module.	5	Make sure that the other end of the lever grabs the front of the chassis to push the module onto the connectors inside the slot.

3	Slide the power supply into the open power supply slot in the chassis until it stops. The front of the module is 0.25 inches (0.6 cm) in front of the chassis.	
---	--	--

4. Slide the power supply gently into the slot until it stops with the front of the module even with the front of the chassis.

If the face of the module is about 0.25 inches (0.6 cm) in front of the module, slide the middle handle on the release lever toward the end of the lever and rotate the lever away from the power supply module. Then gently push the module all the way into the slot.

5. Rotate the ejector lever toward the front of the power supply and be sure that the other end of the lever locks into the chassis.

The lever clicks when you rotate it all the way to the front of the power supply. Be sure that the power supply is fully inserted into the slot. The front of the power supply is even with the surface of the chassis.

b) Connect the power cables to the power supply as follows:

1. Verify that the circuit breakers for both input lines from the DC power source are turned off.
2. Use a torque screwdriver to unscrew three screws on the cover for the terminal box that is located on the front of the power supply. Then lift off the cover as shown in the following figure.

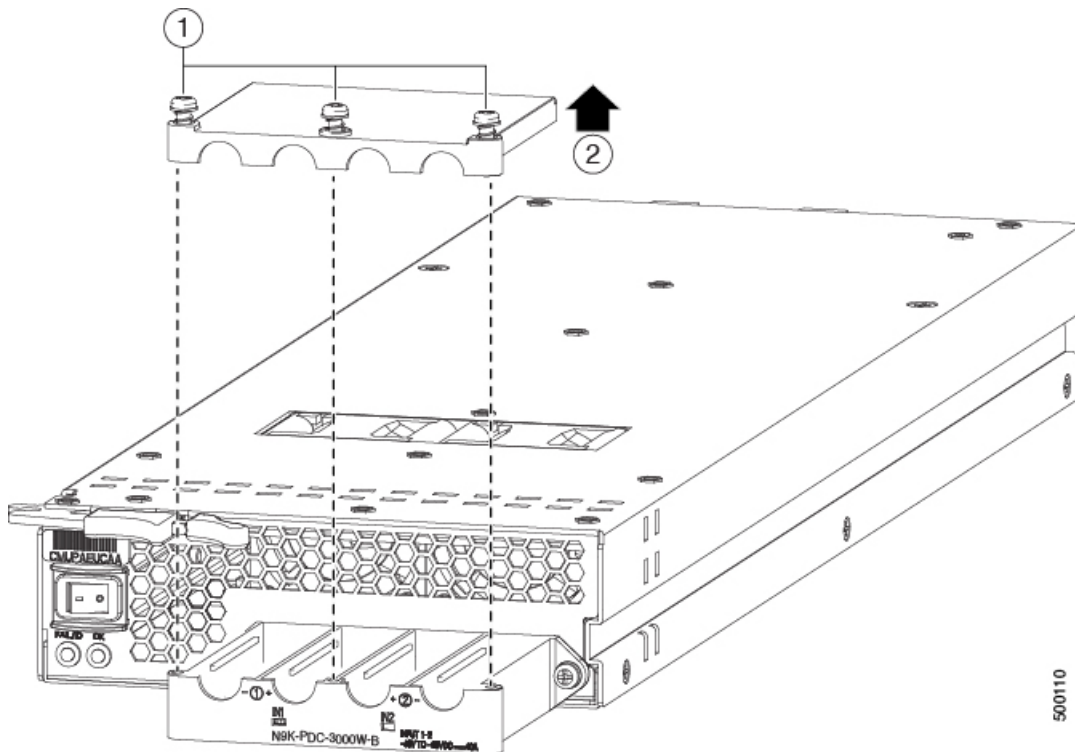

1	Remove 3 screws from the safety cover.	2	Remove the cover.
---	--	---	-------------------

Note The terminal box has four slots for four power terminals (ordered as negative [-], positive [+], positive [+], and negative [-]). Each terminal has two nuts that you use to fasten a power cable to the terminal.

3. Remove the two nuts from each terminal post in each slot of the terminal box.
 4. Place each of the lugs for the two positive cables on the terminal posts for the positive slots (two middle slots) of the terminal box and fasten each lug using two nuts. Tightened the nuts to 40 in-lb (4.5 N·m) of torque.
 5. Place each of the lugs for the two negative cables on the terminal posts for the negative slots (two side slots) of the terminal box and fasten each lug using two nuts. Tightened the nuts to 40 in-lb (4.5 N·m) of torque.
 6. Replace the safety cover on the terminal box and fasten it in place using its three screws.
- c) Power up the power supply as follows:
1. Turn on the power source circuit breaker for both input lines.
Verify that the Input 1 (IN1) and Input 2 (IN2) LEDs light up on the power supply.
 2. Turn the power switch on the power supply to ON (labeled 1 on the power supply).
The LEDs flashes and then the OK LED turns on (green) in addition to the Input LEDs.

What to do next

You are ready to connect the switch to the network.

