



Cisco Nexus 93128TX ACI-Mode Switch Hardware Installation Guide

First Published: 2014-11-07

Last Modified: 2024-10-22

Americas Headquarters

Cisco Systems, Inc.
170 West Tasman Drive
San Jose, CA 95134-1706
USA
<http://www.cisco.com>
Tel: 408 526-4000
800 553-NETS (6387)
Fax: 408 527-0883

THE SPECIFICATIONS AND INFORMATION REGARDING THE PRODUCTS REFERENCED IN THIS DOCUMENTATION ARE SUBJECT TO CHANGE WITHOUT NOTICE. EXCEPT AS MAY OTHERWISE BE AGREED BY CISCO IN WRITING, ALL STATEMENTS, INFORMATION, AND RECOMMENDATIONS IN THIS DOCUMENTATION ARE PRESENTED WITHOUT WARRANTY OF ANY KIND, EXPRESS OR IMPLIED.

The Cisco End User License Agreement and any supplemental license terms govern your use of any Cisco software, including this product documentation, and are located at: <http://www.cisco.com/go/softwareterms>. Cisco product warranty information is available at <http://www.cisco.com/go/warranty>. US Federal Communications Commission Notices are found here <http://www.cisco.com/c/en/us/products/us-fcc-notice.html>.

IN NO EVENT SHALL CISCO OR ITS SUPPLIERS BE LIABLE FOR ANY INDIRECT, SPECIAL, CONSEQUENTIAL, OR INCIDENTAL DAMAGES, INCLUDING, WITHOUT LIMITATION, LOST PROFITS OR LOSS OR DAMAGE TO DATA ARISING OUT OF THE USE OR INABILITY TO USE THIS MANUAL, EVEN IF CISCO OR ITS SUPPLIERS HAVE BEEN ADVISED OF THE POSSIBILITY OF SUCH DAMAGES.

Any products and features described herein as in development or available at a future date remain in varying stages of development and will be offered on a when-and if-available basis. Any such product or feature roadmaps are subject to change at the sole discretion of Cisco and Cisco will have no liability for delay in the delivery or failure to deliver any products or feature roadmap items that may be set forth in this document.

Any Internet Protocol (IP) addresses and phone numbers used in this document are not intended to be actual addresses and phone numbers. Any examples, command display output, network topology diagrams, and other figures included in the document are shown for illustrative purposes only. Any use of actual IP addresses or phone numbers in illustrative content is unintentional and coincidental.

The documentation set for this product strives to use bias-free language. For the purposes of this documentation set, bias-free is defined as language that does not imply discrimination based on age, disability, gender, racial identity, ethnic identity, sexual orientation, socioeconomic status, and intersectionality. Exceptions may be present in the documentation due to language that is hardcoded in the user interfaces of the product software, language used based on RFP documentation, or language that is used by a referenced third-party product.

Cisco and the Cisco logo are trademarks or registered trademarks of Cisco and/or its affiliates in the U.S. and other countries. To view a list of Cisco trademarks, go to this URL: [www.cisco.com go trademarks](http://www.cisco.com/go/trademarks). Third-party trademarks mentioned are the property of their respective owners. The use of the word partner does not imply a partnership relationship between Cisco and any other company. (1721R)

© 2014–2024 Cisco Systems, Inc. All rights reserved.



CONTENTS

Trademarks ?

PREFACE

Preface vii

Audience vii

Documentation Conventions vii

Related Documentation viii

Documentation Feedback ix

Communications, Services, and Additional Information ix

CHAPTER 1

Overview 1

Overview 1

CHAPTER 2

Preparing the Site 5

Temperature Requirements 5

Humidity Requirements 5

Altitude Requirements 5

Dust and Particulate Requirements 6

Minimizing Electromagnetic and Radio Frequency Interference 6

Shock and Vibration Requirements 7

Grounding Requirements 7

Planning for Power Requirements 7

Airflow Requirements 9

Rack and Cabinet Requirements 9

Clearance Requirements 10

CHAPTER 3

Installing the Chassis 13

Installation Options with Rack-Mount Kits	13
Install a Rack	13
Unpacking and Inspecting a New Switch	14
Planning How to Position the Chassis in the Rack	15
Installing the Chassis in a Two-Post Rack	16
Attaching Center-Mount Brackets to the Chassis	16
Installing the Chassis in a Two-Post Rack	17
Installing the Chassis in a Four-Post Rack	19
Installing the Switch using the N9K-C9300-RMK Rack-mount Kit	19
Attaching the Bottom-Support Rails to the Rack	19
Attaching Front-Mount Brackets to the Chassis	21
Installing the Chassis in a Four-Post Rack	22
Grounding the Chassis	24
Starting the Switch	26

CHAPTER 4

Connecting the Switch to the ACI Fabric	29
ACI Fabric Topology	29
Preparing to Connect to Other Devices	30
Connecting Leaf Switches to APICs	31
Connecting Leaf Switches to Spine Switches	33
Installing a Gigabit Ethernet module (GEM)	34
Replacing an Existing Switch in the ACI Fabric	34
Setting Up an Optional Console Interface	34
Setting Up an Optional Management Connection	35
Maintaining Transceivers and Optical Cables	35

CHAPTER 5

Replacing Modules	37
Replacing the Uplink Module	37
Replacing a Fan Module During Operations	38
Replacing a Power Supply Module	40
Removing an AC Power Supply	40
Removing a DC Power Supply	41
Installing an AC Power Supply	41
Installing a DC Power Supply	42

Wiring a 48 V DC Electrical Connector Block 43

APPENDIX A

Rack Specifications 45

- Overview of Racks 45
- General Requirements for Cabinets and Racks 45
- Requirements Specific to Standard Open Racks 46
- Requirements Specific to Perforated Cabinets 46
- Cable Management Guidelines 46

APPENDIX B

System Specifications 47

- Environmental Specifications 47
- Switch Dimensions 47
- Switch and Module Weights and Quantities 48
- Transceiver and Cable Specifications 48
- Switch Power Input Requirements 48
- Power Specifications 49
 - 1200-W AC Power Supply Specifications 49
 - 930-W DC Power Supply (Port-Side Intake) Specifications 49
 - 930-W DC Power Supply (Port-Side Exhaust) Specifications 50
- Power Cable Specifications 50
 - Power Cable Specifications for AC Power Supplies 50
 - DC Power Cable Specifications 51
- Regulatory Standards Compliance Specifications 52

APPENDIX C

LEDs 55

- Switch Chassis LEDs 55
- Uplink Module LEDs 56
- Fan Module LEDs 56
- Power Supply LEDs 56

APPENDIX D

Additional Kits 59

- Rack Mount Kit N9K-C9300-RMK 59

APPENDIX E

Site Preparation and Maintenance Records 61

Site Preparation Checklist 61

Contact and Site Information 62

Chassis and Module Information 63



Preface

This preface includes the following sections:

- [Audience, on page vii](#)
- [Documentation Conventions, on page vii](#)
- [Related Documentation, on page viii](#)
- [Documentation Feedback, on page ix](#)
- [Communications, Services, and Additional Information, on page ix](#)

Audience

This publication is for network administrators who install, configure, and maintain Cisco Nexus switches.

Documentation Conventions

Command descriptions use these conventions:

Convention	Description
bold	Bold text indicates the commands and keywords that you enter literally as shown.
<i>Italic</i>	Italic text indicates arguments for which the user supplies the values.
[x]	Square brackets enclose an optional element (keyword or argument).
[x y]	Square brackets enclosing keywords or arguments separated by a vertical bar indicate an optional choice.
{x y}	Braces enclosing keywords or arguments separated by a vertical bar indicate a required choice.
[x {y z}]	Nested set of square brackets or braces indicate optional or required choices within optional or required elements. Braces and a vertical bar within square brackets indicate a required choice within an optional element.

Convention	Description
<i>variable</i>	Indicates a variable for which you supply values, in context where italics cannot be used.
string	A nonquoted set of characters. Do not use quotation marks around the string or the string will include the quotation marks.

Examples use these conventions:

Convention	Description
<code>screen font</code>	Terminal sessions and information the switch displays are in screen font.
boldface screen font	Information you must enter is in boldface screen font.
<i>italic screen font</i>	Arguments for which you supply values are in italic screen font.
<>	Nonprinting characters, such as passwords, are in angle brackets.
[]	Default responses to system prompts are in square brackets.
!,#	An exclamation point (!) or a pound sign (#) at the beginning of a line of code indicates a comment line.

Related Documentation

Cisco Application Centric Infrastructure (ACI) Documentation

The ACI documentation is available at the following URL: <http://www.cisco.com/c/en/us/support/cloud-systems-management/application-policy-infrastructure-controller-apic/tsd-products-support-series-home.html>.

Cisco Application Centric Infrastructure (ACI) Simulator Documentation

The Cisco ACI Simulator documentation is available at <http://www.cisco.com/c/en/us/support/cloud-systems-management/application-centric-infrastructure-simulator/tsd-products-support-series-home.html>.

Cisco Nexus 9000 Series Switches Documentation

The Cisco Nexus 9000 Series Switches documentation is available at <http://www.cisco.com/c/en/us/support/switches/nexus-9000-series-switches/tsd-products-support-series-home.html>.

Cisco Application Virtual Switch Documentation

The Cisco Application Virtual Switch (AVS) documentation is available at <http://www.cisco.com/c/en/us/support/switches/application-virtual-switch/tsd-products-support-series-home.html>.

Cisco Application Centric Infrastructure (ACI) Integration with OpenStack Documentation

Cisco ACI integration with OpenStack documentation is available at <http://www.cisco.com/c/en/us/support/cloud-systems-management/application-policy-infrastructure-controller-apic/tsd-products-support-series-home.html>.

Documentation Feedback

To provide technical feedback on this document, or to report an error or omission, please send your comments to apic-docfeedback@cisco.com. We appreciate your feedback.

Communications, Services, and Additional Information

- To receive timely, relevant information from Cisco, sign up at [Cisco Profile Manager](#).
- To get the business impact you're looking for with the technologies that matter, visit [Cisco Services](#).
- To submit a service request, visit [Cisco Support](#).
- To discover and browse secure, validated enterprise-class apps, products, solutions and services, visit [Cisco DevNet](#).
- To obtain general networking, training, and certification titles, visit [Cisco Press](#).
- To find warranty information for a specific product or product family, access [Cisco Warranty Finder](#).

Cisco Bug Search Tool

[Cisco Bug Search Tool](#) (BST) is a web-based tool that acts as a gateway to the Cisco bug tracking system that maintains a comprehensive list of defects and vulnerabilities in Cisco products and software. BST provides you with detailed defect information about your products and software.



CHAPTER 1

Overview

- [Overview, on page 1](#)

Overview

The Cisco Nexus 93128TX switch (N9K-C93128TX) is a 3-RU, fixed-port switch designed for spine-leaf-APIC deployment in data centers. This switch has 96 fixed 1/10GBASE-T (copper) ports that support 100-Megabit, 1-Gigabit, and 10-Gigabit Ethernet for APIC connections and 6 or 12 fixed 40-Gigabit ports provided through an uplink module (for this switch, the 12-port uplink module has only eight active ports) for connections to spine switches. The chassis for this switch includes the following user-replaceable components:

- Uplink modules (one of either of the following for uplink ports)
 - M6PQ uplink module (six-port, 40-Gigabit Ethernet)
 - M6PQ-E uplink module (six-port, 40-Gigabit Ethernet)
 - M12PQ uplink module (12-port (8 active ports), 40-Gigabit Ethernet)
- Fan modules (three—two for operations and one for redundancy [2+1]) with the following airflow choices:
 - Port-side-intake fan module with burgundy coloring (N9K-C9300-FAN2)
 - Port-side-exhaust fan module with blue coloring (N9K-C9300-FAN2-B)
- Power supply modules (two—one for operations and one for redundancy [1+1]) with the following choices:
 - 1200-W AC power supply with port-side intake airflow (burgundy coloring) (N9K-PAC-1200W)
 - 1200-W AC power supply with port-side exhaust airflow (blue coloring) (N9K-PAC-1200W-B)
 - 930-W port-side intake DC power supply with green coloring (UCSC-PSU-930WDC)
 - 930-W port-side exhaust DC power supply with gray coloring (UCS-PSU-6332-DC)



Note Both power supplies should be the same type. Do not mix AC and DC power supplies.



Note All fan modules and power supplies must use the same airflow direction during operations.

The following figure shows the hardware features seen from the port side of the chassis.

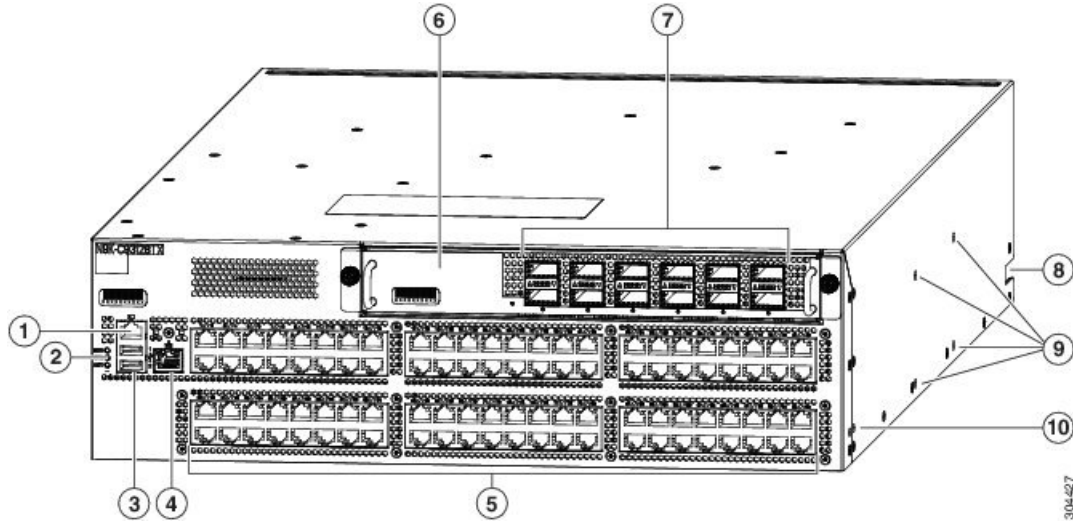

<p>1 Console port (RS232 port)</p>	<p>6 M6PQ, M6PQ-E, or M12PQ uplink module (M12PQ uplink module shown).</p>
<p>2 Chassis LEDs</p> <ul style="list-style-type: none"> • Beacon (BCN) • Status (STS) • Environment (ENV) 	<p>7 6 or 12 40-Gigabit Ethernet Quad Small Form-Factor Plugable (QSFP+) optical ports for uplink connections to spine switches (12-port uplink module shown)</p> <p>Note For this switch, the 12-port module has only 8 active ports (leftmost ports).</p>
<p>3 2 USB ports used for saving or copying functions</p> <p>Note USB support is limited to USB 2.0 devices that use less than 2.5 W (less than 0.5 A inclusive of surge current). Devices, such as external hard drives, that instantaneously draw more than 0.5 A are not supported.</p>	<p>8 Notch in both sides of the chassis for locking the power supply end of the chassis to the bottom-support rails</p>
<p>4 Out-of-band management port (RJ-45 port)</p>	<p>9 Screw holes (4) for attaching a center-mount rack bracket for 2-post racks (one bracket for each of two sides)</p>

5	96 10GBASE-T copper ports (supporting 100-Megabit, 1-Gigabit, and 10-Gigabit Ethernet) to Application Policy Infrastructure Controllers (APICs)	10	Screw holes (2) for attaching a front-mount bracket for 4-post racks (1 bracket on each of 2 sides)
---	---	----	---

To determine which transceivers, adapters, and cables are supported by this switch, see the [Cisco Transceiver Modules Compatibility Information](#) document.

The following figure shows the hardware features seen from the fan side of the chassis.

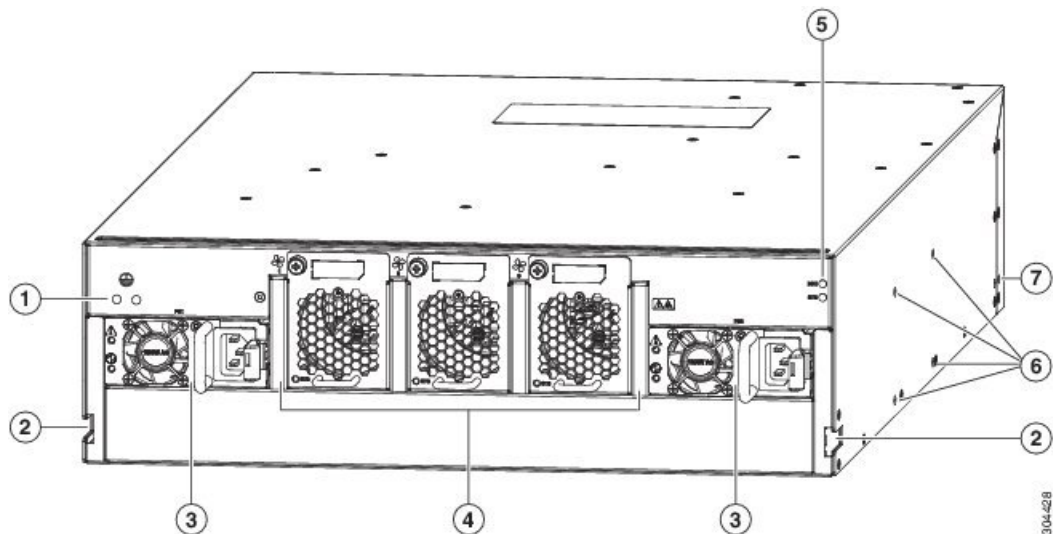

1	Screw holes (2) for attaching the grounding lug.	5	Chassis LEDs include the following: <ul style="list-style-type: none"> • Beacon (BCN) • Status (STS)
2	A notch in both sides of the chassis for locking the fan side of the chassis to the bottom-support rails.	6	Screw holes (4) for attaching a center-mount rack bracket for 2-post racks (1 bracket for each of 2 sides).
3	Two power supply modules (one used for operations and one used for redundancy) (AC power supplies shown) with slots numbered 1 (left side) and 2 (right side).	7	Screw holes (2) for attaching a front-mount bracket for 4-post racks (1 bracket on each of 2 sides).
4	Three fan modules (two used for operations and one used for redundancy) with slots numbered from 1 (left side) to 3 (right side)		

Depending on whether you plan to position the ports in a hot or cold aisle, you can order the fan and power supply modules with port-side intake or port-side exhaust airflow. For port-side intake airflow, the fan modules have burgundy coloring (DC power supply modules have green coloring). For port-side exhaust airflow, the fan modules have blue coloring (DC power supply modules have gray coloring).

The fan and power supply modules are field replaceable and you can replace one fan module or one power supply module during operations so long as the other modules are installed and operating. If you have only

one power supply installed, you can install the replacement power supply in the open slot before removing the original power supply.



Note All of the fan and power supply modules must have the same direction of airflow. Otherwise, the switch can overheat and shut down.



Caution If the switch has port-side intake airflow (burgundy coloring for fan modules), you must locate the ports in the cold aisle. If the switch has port-side exhaust airflow (blue coloring for fan modules), you must locate the ports in the hot aisle. If you locate the air intake in a hot aisle, the switch can overheat and shut down.



CHAPTER 2

Preparing the Site

- [Temperature Requirements, on page 5](#)
- [Humidity Requirements, on page 5](#)
- [Altitude Requirements, on page 5](#)
- [Dust and Particulate Requirements, on page 6](#)
- [Minimizing Electromagnetic and Radio Frequency Interference, on page 6](#)
- [Shock and Vibration Requirements, on page 7](#)
- [Grounding Requirements, on page 7](#)
- [Planning for Power Requirements, on page 7](#)
- [Airflow Requirements, on page 9](#)
- [Rack and Cabinet Requirements, on page 9](#)
- [Clearance Requirements, on page 10](#)

Temperature Requirements

The operating temperature of the switch is 32 to 104 degrees Fahrenheit (0 to 40 degrees Celsius). The non-operating temperature of the switch is -40 to 158 degrees Fahrenheit (-40 to 70 degrees Celsius).

Humidity Requirements

High humidity can cause moisture to enter the switch. Moisture can cause corrosion of internal components and degradation of properties such as electrical resistance, thermal conductivity, physical strength, and size. The switch is rated to withstand from 5- to 95-percent (nonoperating) and 5- to 90-percent (operating) relative humidity.

Climate-controlled buildings usually maintain an acceptable level of humidity for the switch equipment. If the switch is located in an unusually humid location, use a dehumidifier to maintain the humidity within an acceptable range.

Altitude Requirements

Altitude rating is 10,000 ft (3048 m). For China, it is 6,562 ft (2000 m).

Dust and Particulate Requirements

Exhaust fans cool power supplies. System fans cool switches by drawing in air and exhausting air out through various openings in the chassis. Fans also introduce dust and other particles, causing contaminant buildup in the switch and increased internal chassis temperature. Dust and particles can act as insulators and interfere with the mechanical components in the switch. Keep a clean operating environment to reduce the negative effects of dust and other particles.

In addition to keeping your environment free of dust and particles, use these precautions to avoid contamination of your switch:

- Do not smoke near the switch.
- Do not eat or drink near the switch.

Minimizing Electromagnetic and Radio Frequency Interference

Electromagnetic interference (EMI) and radio frequency interference (RFI) from the switch can adversely affect other devices, such as radio and television (TV) receivers. Radio frequencies that emanate from the switch can also interfere with cordless and low-power telephones. Conversely, RFI from high-power telephones can cause spurious characters to appear on the switch monitor.

RFI is defined as any EMI with a frequency above 10 kHz. This type of interference can travel from the switch to other devices through the power cable and power source or through the air as transmitted radio waves. The Federal Communications Commission (FCC) publishes specific regulations to limit the amount of EMI and RFI that are emitted by computing equipment. Each switch meets these FCC regulations.

To reduce the possibility of EMI and RFI, use these guidelines:

- Cover all open expansion slots with a blank filler plate.
- Always use shielded cables with metal connector shells for attaching peripherals to the switch.

When wires are run for any significant distance in an electromagnetic field, interference can occur to the signals on the wires with these implications:

- Bad wiring can result in radio interference emanating from the plant wiring.
- Strong EMI, especially when it is caused by lightning or radio transmitters, can destroy the signal drivers and receivers in the chassis and even create an electrical hazard by conducting power surges through lines into equipment.



Note To predict and prevent strong EMI, consult experts in radio frequency interference (RFI).

The wiring is unlikely to emit radio interference if you use a twisted-pair cable with a good distribution of grounding conductors. If you exceed the recommended distances, use a high-quality twisted-pair cable with one ground conductor for each data signal, when applicable.

**Caution**

If the wires exceed the recommended distances, or if wires pass between buildings, give special consideration to the effect of a lightning strike in your vicinity. The electromagnetic pulse that is caused by lightning or other high-energy phenomena can easily couple enough energy into unshielded conductors to destroy electronic switches. Consult experts in electrical surge suppression and shielding if you have had similar problems in the past.

Shock and Vibration Requirements

The switch has been shock- and vibration-tested for operating ranges, handling, and earthquake standards.

Grounding Requirements

The switch is sensitive to variations in voltage that is supplied by the power sources. Overvoltage, undervoltage, and transients (spikes) can erase data from memory or cause components to fail. To protect against these types of problems, ensure that there is an earth-ground connection for the switch. Connect the grounding pad on the switch either directly to the earth-ground connection or to a fully bonded and grounded rack.

When the chassis is properly installed in a grounded rack, the switch is grounded because it has a metal-to-metal (no paint, stain, dirt, or anything else on it) connection to the rack. Alternatively, ground the chassis by using a customer-supplied grounding cable that meets your local and national installation requirements. For U.S. installations, we recommend 6-AWG wire. Connect your grounding cable to the chassis with a grounding lug (provided in the switch accessory kit) and to the facility ground.

**Note**

You automatically ground AC power supplies when you connect them to AC power sources. For DC power supplies, you must connect a grounding wire when wiring the power supply to the DC power source.

**Note**

Create an electrical conducting path between the product chassis and the metal surface of the enclosure, or rack in which it is mounted, or to a grounding conductor. Provide electrical continuity by using thread-forming type mounting screws that remove any paint or non-conductive coatings and establish a metal-to-metal contact. Remove any paint or other non-conductive coatings on the surfaces between the mounting hardware and the enclosure or rack. Clean the surfaces and apply an antioxidant before installation.

Planning for Power Requirements

The switch includes two power supplies (1-to-1 redundancy with current sharing) in one of these combinations:

- Two 1200-W AC power supplies
- Two 930-W DC power supplies



Note Both power supplies must be the same type. Do not mix AC and DC power supplies in the same chassis.



Note For 1+1 redundancy, you must use two power sources and connect each power supply to a separate power source.

The power supplies are rated to output up to either 1200 W (AC power supplies) or 930 W (DC power supplies) but the switch requires less than those amounts of power from the power supply. To operate the switch, you must provision enough power from the power source to cover the requirements of both the switch and a power supply. Typically, this switch and a power supply require about 582 W of power input from the power source, but you must provision as much as 853 W power input from the power source to cover peak demand.



Note Some of the power supply modules have rating capabilities that exceed the switch requirements. When calculating your power requirements, use the switch requirements to determine the amount of power that is required for the power supplies.

To minimize the possibility of circuit failure, verify that each power-source circuit that is used by the switch is dedicated to the switch.



Note This Warning applies to DC input application.



Warning **Statement 1005**—Circuit Breaker when using DC power supplies

This product relies on the building's installation for short-circuit (overcurrent) protection.

- Ensure that the protective devices are rated not greater than 30A when the switch is powered with regular DC power supplies (rated 48-60VDC).
 - Ensure that the protective devices are rated not greater than 10A when the switch is powered with HVDC power supplies (rated 240-350VDC).
-



Warning **Statement 1033**—Safety Extra-Low Voltage (SELV)—IEC 60950/ES1—IEC 62368 DC Power Supply

To reduce the risk of electric shock, connect the unit to a DC power source that complies with the SELV requirements in IEC 60950-based safety standards or ES1 and PS1 requirements in IEC 62368-based safety standards or to a Class 2 power supply.



Note We recommend 8-AWG wire for DC installations in the U.S.

Airflow Requirements

The switch is positioned with its ports in either the front or the rear of the rack, depending on your cabling and maintenance requirements. To identify the airflow options for your switch, see the user-replaceable components in the *Overview* section of this document. Position the fan and power supply modules to move the coolant air from the cold aisle to the hot aisle in one of these ways:

- Port-side exhaust airflow—Cool air enters the chassis through the fan and power supply modules in the cold aisle and exhausts through the port end of the chassis in the hot aisle.
- Port-side intake airflow—Cool air enters the chassis through the port end in the cold aisle and exhausts through the fan and power supply modules in the hot aisle.

Identify the airflow direction of each fan and power supply module by its coloring.

- Blue coloring indicates port-side exhaust airflow.
- Gray coloring on DC power supplies indicates port-side exhaust airflow.
- Green coloring on DC power supplies indicates port-side intake airflow.



Note To prevent the switch from overheating and shutting down, position the air intake for the switch in a cold aisle. The fan and power supply modules must have the same direction of airflow. To change the airflow direction for the switch, shutdown the switch before changing the modules.

Rack and Cabinet Requirements

Install these types of racks or cabinets for your switch:

- Standard perforated cabinets
- Solid-walled cabinets with a roof fan tray (bottom-to-top cooling)
- Standard open four-post Telco racks
- Standard open two-post Telco racks



Note Installation into a two-post rack is not suggested, nor is it earthquake safe nor NEBS compliant

Work with your cabinet vendors to determine which of their cabinets meet these requirements or see the Cisco Technical Assistance Center (TAC) for recommendations:

- Use a standard 19-inch (48.3-cm), four-post Electronic Industries Alliance (EIA) cabinet or rack with mounting rails that conform to English universal hole spacing per section 1 of the ANSI/EIA-310-D-1992 standard.
- The depth of a four-post rack must be 24 to 32 inches (61.0 to 81.3 cm) between the front and rear mounting rails (for proper mounting of the bottom-support brackets or other mounting hardware).
- Required clearances between the chassis and the edges of its rack or the interior of its cabinet are as follows:
 - 4.5 inches (11.4 cm) between the front of the chassis and the interior of the cabinet (required for cabling).
 - 3.0 inches (7.6 cm) between the rear of the chassis and the interior of the cabinet (required for airflow in the cabinet if used).
 - No clearance is required between the chassis and the sides of the rack or cabinet (no side airflow).

Also, you must have power receptacles that are located within reach of the power cords that are used with the switch.



Warning Statement 1048—Rack Stabilization

The rack stabilizing mechanism must be in place, or the rack must be bolted to the floor before installation or servicing. Failure to stabilize the rack can cause bodily injury.

Clearance Requirements

Provide the chassis with adequate clearance between the chassis and any other rack, device, or structure so that you can properly install the it. Provide the chassis with adequate clearance to route cables, provide airflow, and maintain the switch. For the clearances required for an installation of this chassis in a four-post rack, see the figure.

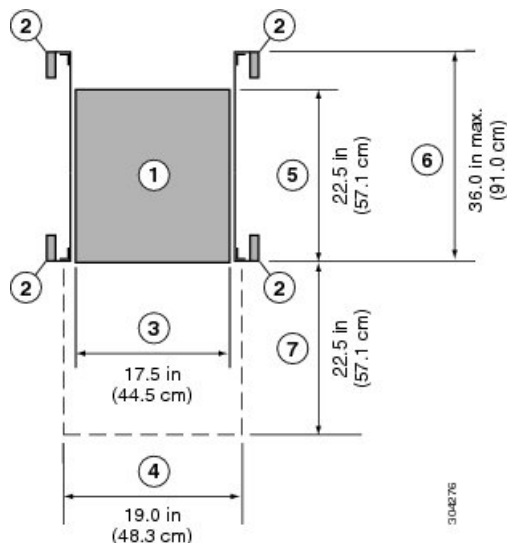

1	Chassis	5	Depth of the chassis
2	Vertical rack-mount posts and rails	6	Maximum extension of the bottom-support rails 36.0 in (91.0 cm)
3	Chassis width 17.3 in (43.9 cm)	7	Depth of the front clearance area (equal to the depth of the chassis).
4	Width of the front clearance area (equal to the width of the chassis with two rack-mount brackets that are attached to it). 19.0 in (43.3 cm)		

For the clearances required for a two-post rack installation, see figure.

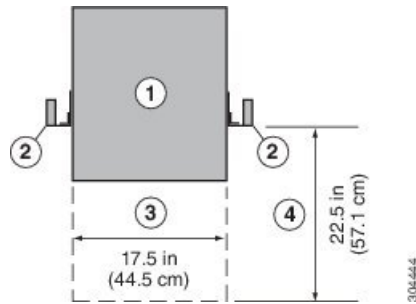

1	Chassis	3	Chassis width
2	Vertical rack-mount posts and rails	4	Service clearance that is required for replacing the chassis (equals the length of the chassis).



Note Both the front and rear of the chassis must be open to both aisles for airflow.



CHAPTER 3

Installing the Chassis

- [Installation Options with Rack-Mount Kits, on page 13](#)
- [Install a Rack, on page 13](#)
- [Unpacking and Inspecting a New Switch, on page 14](#)
- [Planning How to Position the Chassis in the Rack, on page 15](#)
- [Installing the Chassis in a Two-Post Rack, on page 16](#)
- [Installing the Chassis in a Four-Post Rack, on page 19](#)
- [Grounding the Chassis, on page 24](#)
- [Starting the Switch, on page 26](#)

Installation Options with Rack-Mount Kits

The rack-mount kit enables you to install the switch into racks of varying depths. You can position the switch with easy access to either the port connections or the fan and power supply modules.

Install the switch using these rack-mount options:

The rack or cabinet that you use must meet the requirements listed in [General Requirements for Cabinets and Racks, on page 45](#) section.



Note You are responsible for verifying that your rack and rack-mount hardware comply with the guidelines that are described in this document.

Install a Rack

Before you install the switch, you must install a standard two- or four-post, 19-inch EIA data center rack (or a cabinet that contains such a rack) that meets the requirements listed in [Overview of Racks, on page 45](#).

Step 1 Bolt the rack to the concrete subfloor before moving the chassis onto it.

Warning **Statement 1048**—Rack Stabilization

The rack stabilizing mechanism must be in place, or the rack must be bolted to the floor before installation or servicing. Failure to stabilize the rack can cause bodily injury.

- Step 2** If the rack has bonded construction, connect it to the earth ground. This action enables you to easily ground the switch and its components and to ground your electrostatic discharge (ESD) wrist strap to prevent damaging discharges when you handle ungrounded components before installing them.
- Step 3** Include one or two power sources at the rack. For AC power, provide a power receptacle. For DC power, provide a circuit breaker with terminals for connecting power cables.

Warning Statement 1018—Supply Circuit

To reduce risk of electric shock and fire, take care when connecting units to the supply circuit so that wiring is not overloaded.

Note If you are not using power redundancy or are using $n+1$ redundancy, you need only one power source. If you are using $n+n$ redundancy, you need two power sources.

Unpacking and Inspecting a New Switch

Before you install a new chassis, unpack and inspect it to be sure that you have all the items that you ordered. Verify that the switch was not damaged during shipment. If anything is damaged or missing, contact your customer representative immediately.



Caution

When you handle the chassis or its components, follow ESD protocol at all times to prevent ESD damage. This protocol includes but is not limited to wearing an ESD wrist strap that you connect to the earth ground.



Tip

Do not discard the shipping container when you unpack the switch. Flatten the shipping cartons and store them. If you need to move or ship the system in the future, you will need this container.

- Step 1** Compare the shipment to the equipment list that is provided by your customer service representative. Verify that you have received all of the ordered items.

The shipment should include:

- Switch chassis, which includes these installed components:
 - One uplink module:
 - M6PQ uplink module
 - M6PQ-E uplink module
 - M12PQ uplink module
- Two power supplies (any combination of these, with the airflow direction being the same as for the fan modules):
 - 1200-W AC power supply
 - Port-side exhaust airflow with blue coloring (N9K-PAC-1200W-B)

- Port-side intake airflow with burgundy coloring (N9K-PAC-1200W)
- 930-W DC power supply
 - Port-side exhaust airflow with gray coloring (UCS-PSU-6332-DC)
 - Port-side intake airflow with green coloring (UCSC-PDU-930WDC)
- Three fan modules (all fan and power supply modules must have the same airflow direction)
 - Port-side exhaust airflow with blue coloring (N9K-C9300-FAN2-B)
 - Port-side intake airflow with burgundy coloring (N9K-C9300-FAN2)
- Switch accessory kit
- Rack mount kit

Step 2 Check the contents of the box for damage.

Step 3 If you notice any discrepancies or damage, send this information to your customer service representative by email:

- Invoice number of the shipper (see the packing slip)
- Model and serial number of the missing or damaged unit
- Description of the problem and how it affects the installation

Planning How to Position the Chassis in the Rack

The switch is designed so that you can have coolant air flow through the switch in one of two directions:

- Enter the port side and exhaust out the power supply side (port-side intake airflow)
- Enter the power supply side and exhaust out the port side (port-side exhaust airflow)

For port-side intake airflow, the switch must have port-side intake fan and AC power supply modules with one or more of these colorings:

- Burgundy coloring on fan modules and AC power supplies
- Green coloring on DC power supplies

For port-side exhaust airflow, the switch must have port-side exhaust fan and AC power supply modules with one or more of the following colorings:

- Blue coloring on fan modules and AC power supplies
- Gray coloring on DC power supplies

Plan the positioning of the switch so that its ports are located close to ports on connected devices or so that the fan and power supply modules are conveniently located in a maintenance aisle. Order the modules that move coolant air in the appropriate direction from the cold aisle to the hot aisle.



Note All fan and power supply modules in the same switch must operate with the same direction of airflow. The air intake portion of the switch must be located in a cold aisle.

Installing the Chassis in a Two-Post Rack

Before you install the chassis, be sure that the rack is fully secured to the data center floor.

You must attach mounting brackets to the chassis before mounting the chassis.

Attaching Center-Mount Brackets to the Chassis

You need to attach a right-angled bracket to each side of the chassis. This bracket centers the chassis and secures it in place on a two-post rack.



Warning **Statement 1006**—Chassis Warning for Rack-Mounting and Servicing

To prevent bodily injury when mounting or servicing this unit in a rack, you must take special precautions to ensure that the system remains stable. The following guidelines are provided to ensure your safety:

- This unit should be mounted at the bottom of the rack if it is the only unit in the rack.
 - When mounting this unit in a partially filled rack, load the rack from the bottom to the top with the heaviest component at the bottom of the rack.
 - If the rack is provided with stabilizing devices, install the stabilizers before mounting or servicing the unit in the rack.
-

Before you begin

- You must separately order the center-mount brackets if you are installing the chassis in a two-post rack. These brackets do not ship with the chassis unless you specifically order them.
- You must have the following tools and equipment:
 - Manual Phillips-head torque screwdriver
 - Center-mount bracket kit

Step 1 Align one of the two center-mount brackets on the left or right side of the chassis and be sure that the angled portion is facing the front of the chassis (see the following figure).

Be sure to align four of the screw holes on the larger side of the bracket with the four screw holes near the center of the left or right side of the chassis.

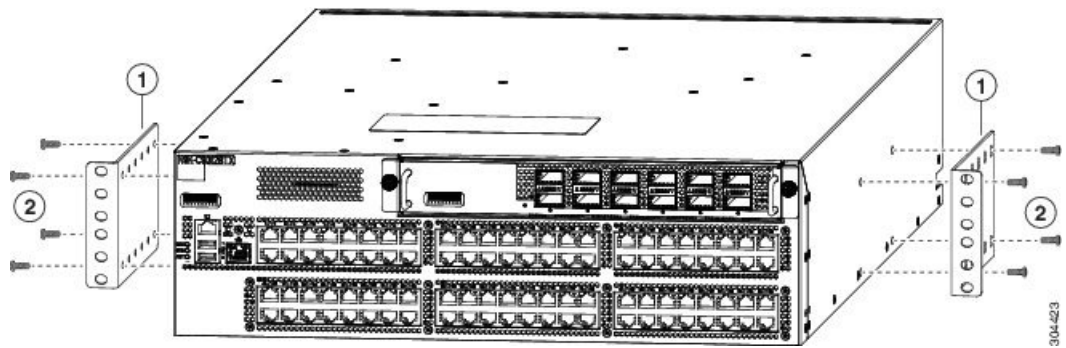

1	Center-mount bracket with its larger side facing the chassis and the longer side facing the front (port side) of the chassis. Align four screw holes in the bracket to four screw holes in the side of the chassis.	2	Four M4 x 8 mm screws used to fasten the bracket to the chassis.
---	---	---	--

- Step 2** Use four M4 x 8 mm screws to attach the bracket to the chassis. Tighten each screw to 11 to 15 in-lb (1.2 to 1.7 N·m).
- Step 3** Repeat Steps 1 and 2 to attach the second center-mount bracket to the other side of the chassis.

What to do next

You are ready to mount the chassis to the two-post rack.

Installing the Chassis in a Two-Post Rack

You need to position the chassis near the top of the rack with the power supply and fan modules in the appropriate aisle for their required airflow. If the fan modules have a blue coloring for port-side exhaust airflow, then you must position the modules by the cold aisle. If the fan modules have a burgundy coloring for port-side intake airflow, you must position the modules by the hot aisle.



Note Power supply modules must have the same airflow direction as the fan modules.



Note Power supply modules must have the same airflow direction as the fan modules but might have different coloring if they use DC power (green coloring for port-side intake airflow or gray coloring for port-side exhaust airflow). HVAC/HVDC power supplies with white coloring use the same direction of airflow as used by the fan modules.



Warning **Statement 1074**—Comply with Local and National Electrical Codes

To reduce risk of electric shock or fire, installation of the equipment must comply with local and national electrical codes.



Warning Statement 1032—Lifting the Chassis

To prevent personal injury or damage to the chassis, never attempt to lift or tilt the chassis using the handles on modules (such as power supplies, fans, or cards); these types of handles are not designed to support the weight of the unit.

Before you begin

- Make sure that the two-post rack is properly installed and secured to the concrete subfloor.
- Make sure that two center-mount brackets are securely fastened to the middle of each side of the chassis.
- Make sure that you have six customer-supplied rack-mount screws (typically M6 x 10 mm or the appropriate screw for the vertical mounting rails on the rack).
- You have at least two people to install the chassis.



Warning Statement 1006—Chassis Warning for Rack-Mounting and Servicing

To prevent bodily injury when mounting or servicing this unit in a rack, you must take special precautions to ensure that the system remains stable. The following guidelines are provided to ensure your safety:

- This unit should be mounted at the bottom of the rack if it is the only unit in the rack.
 - When mounting this unit in a partially filled rack, load the rack from the bottom to the top with the heaviest component at the bottom of the rack.
 - If the rack is provided with stabilizing devices, install the stabilizers before mounting or servicing the unit in the rack.
-

Step 1

Use one person to position the chassis so that it is near the top of the rack with the fan and power supply modules in the appropriate aisle and the center-mount bracket has its screw holes aligned to screw holes on the two-post rack.

If these modules have a blue or gray coloring for port-side exhaust airflow, then you must position the modules by the cold aisle. If the modules have a burgundy or green coloring for port-side intake airflow, you must position the modules by the hot aisle.

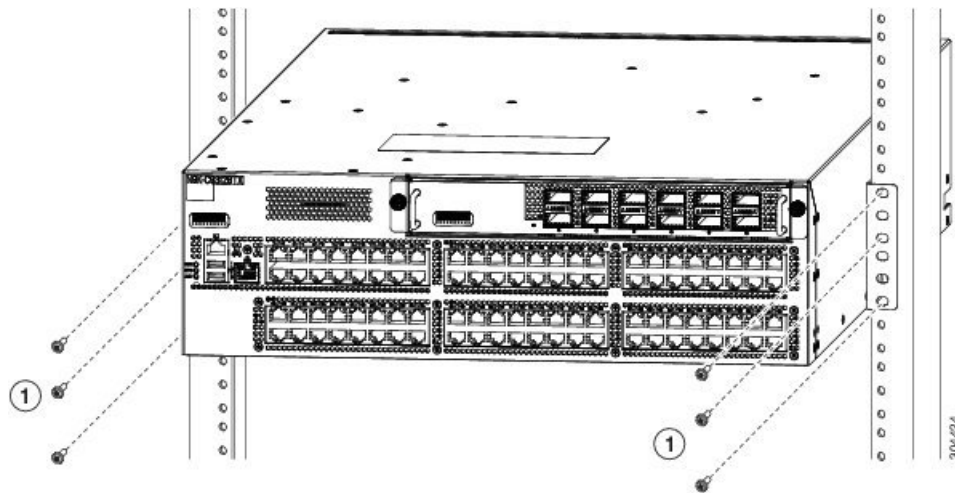

1	Three customer-supplied screws (typically M6 x 10 mm screws or the appropriate screws for the rack) to hold each side of the chassis to the two-post rack.	
---	--	--

Step 2

Use the second person to secure the three customer-supplied rack-mount screws (typically M6 x 10 mm or other appropriate screws for the rack) on each center-mount bracket to attach the chassis to the rack. Tighten each screw to the appropriate torque setting for the screws (for M6 x 10 mm screws, use 40 in-lbs [4.5 N·m] of torque).

Installing the Chassis in a Four-Post Rack

Before you install the chassis, be sure that the rack is fully secured to the data center floor.

Installing the Switch using the N9K-C9300-RMK Rack-mount Kit

Attaching the Bottom-Support Rails to the Rack

The switch chassis that you are installing ships with two adjustable bottom-support rails that you can attach to a four-post rack to hold the chassis. Each of these bottom-support rails has two pieces—one that slides into the other so that you can adjust them to fit racks with front and rear mounting posts that are spaced less than 36 inches (91 cm). On each bottom-support rail, the rail half that slides into the other rail includes a chassis stop that fits into the module end of the chassis. Depending on direction of the chassis airflow, position the rail half with the chassis stop so that the fan and power supply modules end up in the appropriate aisle as follows:

- Port-side intake (burgundy coloring for fan modules) airflow requires that the bottom-support rail with the chassis stop be located on the hot aisle side of the rack.
- Port-side exhaust (blue coloring for fan modules) airflow requires that the bottom-support rail with the chassis stop be located on the cold aisle side of the rack.



Warning Statement 1074—Comply with Local and National Electrical Codes

To reduce risk of electric shock or fire, installation of the equipment must comply with local and national electrical codes.

Before you begin

Before you can install the bottom support rails for the chassis, do this:

- Verify that a four-post rack or cabinet is installed.
- If any other devices are stored in the rack or cabinet, verify that the heavier switches are installed below lighter switches.
- Verify that the bottom-support rails kit is included in the switch accessory kit.
- Verify that you have 8 screws for attaching the bottom support brackets to the racks (typically M6 x 10 mm screws or the screw appropriate for the vertical mounting rails on the rack).



Warning Statement 1006—Chassis Warning for Rack-Mounting and Servicing

To prevent bodily injury when mounting or servicing this unit in a rack, you must take special precautions to ensure that the system remains stable. The following guidelines are provided to ensure your safety:

- This unit should be mounted at the bottom of the rack if it is the only unit in the rack.
 - When mounting this unit in a partially filled rack, load the rack from the bottom to the top with the heaviest component at the bottom of the rack.
 - If the rack is provided with stabilizing devices, install the stabilizers before mounting or servicing the unit in the rack.
-

-
- Step 1** Look at the fan and power supply modules installed in the chassis to determine how you must position the bottom-support rails on the rack.
- If the fan modules have blue coloring (port-side exhaust modules), position the bottom support rails so that the chassis stop is positioned by the cold aisle.
 - If the fan modules have burgundy (port-side intake modules), position the bottom support rails so that the chassis stop is positioned by the hot aisle.
- Step 2** Separate the two sliders that make up one bottom-support rail and position the half with the chassis stop by the appropriate aisle for the fan and power supply modules. Leave at least 1 rack unit open above the bottom-support rails so that you can easily install the chassis.
- Step 3** Use two customer-supplied screws (typically M6 x 10 mm screws) to attach the bottom-support rail half to the vertical mounting rails on the rack post. Tighten each screw to the appropriate torque setting for the screws (for M6 x 10 mm screws, use 40 in. lbs [4.5 N·m] of torque).

- Step 4** Slide the other half of the bottom-support rail onto the attached half of the rail set and use two customer supplied screws (typically M6 x 10 mm screws) to secure that portion to the vertical mounting rails on the rack. Tighten each screw to the appropriate torque setting for the screws (for M6 x 10 mm screws, use 40 in. lbs [4.5 N·m] of torque).

Figure 1: Positioning an Expanding Bottom-Support Rail Set

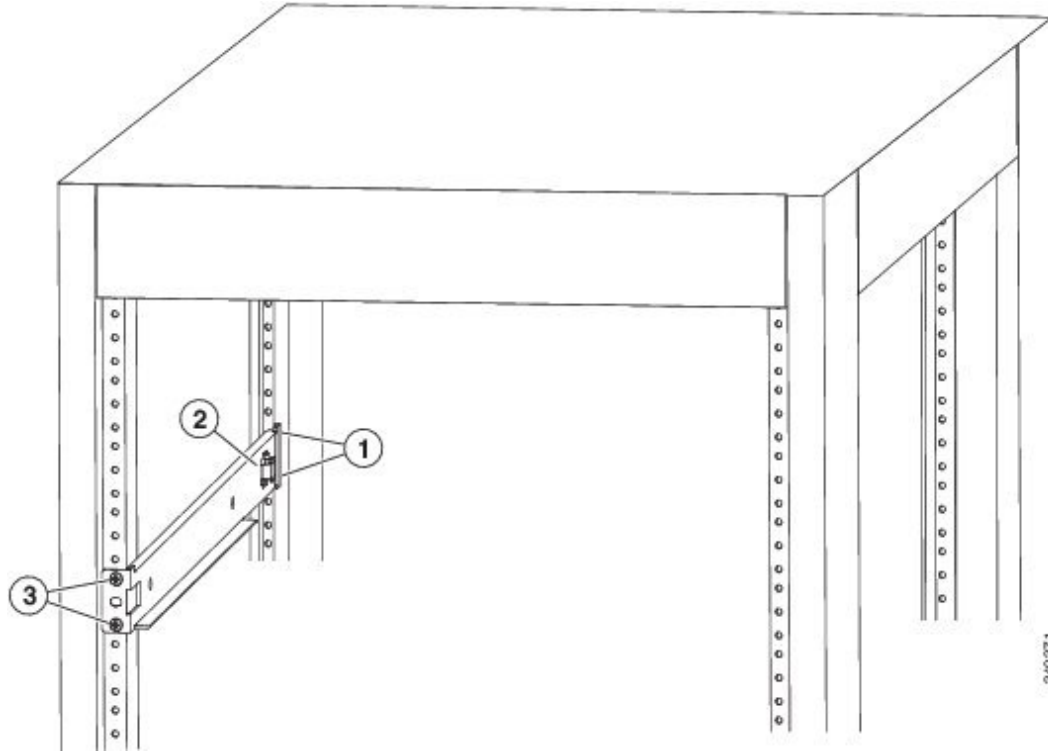

1	2 screws holding one end of the bottom-support bracket to the rear of the rack	3	2 screws holding the front end of the bottom-support bracket to the front side of the rack
2	Chassis stop on the expanding bottom-support bracket		

- Step 5** Repeat Steps 2 and 3 to attach the other expanding bottom-support rails to the other side of the rack.

Note Check the two installed bottom support rails to be sure that both have their chassis stops by the same aisle (either both by the hot aisle or both by the cold aisle) and that both rails are level and level with each other. If they are not level, adjust the higher rail down to the level of the lower rail.

What to do next

You are ready to install two front-mount brackets on the chassis.

Attaching Front-Mount Brackets to the Chassis

Attach a right-angled bracket to each side of the chassis. This bracket holds the chassis in place on a four-post rack.

Before you begin

- You need these tools and equipment:
 - Manual Phillips-head torque screwdriver
 - Front-mount brackets (2) and screws (4). Check the switch accessory kit.

Step 1 Align the two holes in one side of one of two front-mount brackets to two holes on the left or right side of the chassis (see the figure).

Be sure that the other side of the bracket is facing toward the front (port end) of the chassis.

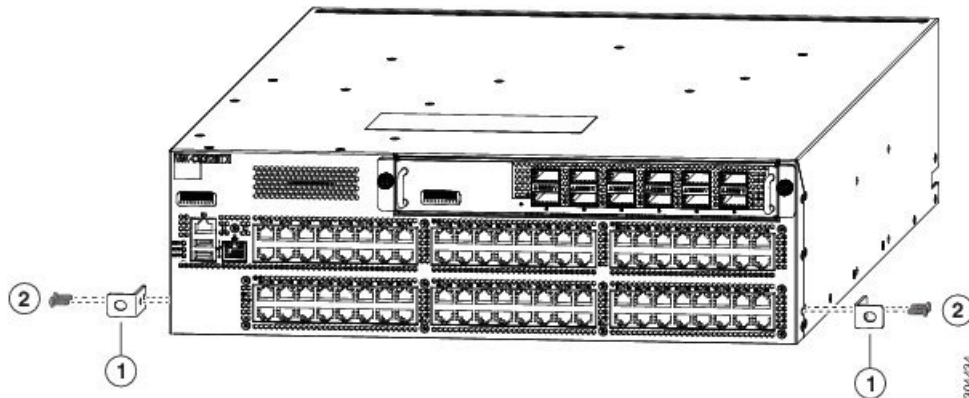

1	Front-mount bracket with two screw holes aligned to two screw holes in the chassis and one screw hole facing the front (port side) of the chassis.	2	Two M4 x 6 mm screws used to fasten the bracket to the chassis.
---	--	---	---

Step 2 Use two M4 x 6 mm screws to attach the bracket to the chassis. Tighten each screw to 11 to 15 in-lb (1.2 to 1.7 Nm).

Step 3 Repeat Steps 1 and 2 to attach the second center-mount bracket to the other side of the chassis.

What to do next

You are ready to mount the chassis to the four-post rack.

Installing the Chassis in a Four-Post Rack

Slide the chassis onto the bottom-support rails so that the power supply end locks onto the chassis stops at the end of the rails and so that the front-mount brackets on the chassis come into contact with the front-mount rails on the rack.



Warning **Statement 1074**—Comply with Local and National Electrical Codes

To reduce risk of electric shock or fire, installation of the equipment must comply with local and national electrical codes.

**Warning Statement 1032—Lifting the Chassis**

To prevent personal injury or damage to the chassis, never attempt to lift or tilt the chassis using the handles on modules (such as power supplies, fans, or cards); these types of handles are not designed to support the weight of the unit.

Before you begin

- Make sure that the four-post rack is properly installed and secured to the concrete subfloor.
- Make sure that the bottom-support rails are installed so that the fan modules will be in the appropriate aisle as follows:
 - Burgundy (port-side intake airflow) fan modules are positioned in a hot aisle (the chassis stop on the bottom-support rails is positioned by the hot aisle).
 - Blue colored (port-side exhaust airflow) fan modules are positioned in a cold aisle (the chassis stop on the bottom-support rails is positioned by the cold aisle).
- Make sure that two front-mount brackets are securely fastened to the sides of the chassis at the port end.
- Make sure that you have two customer-supplied rack-mount screws (M6 x 10 mm or appropriate screw for the vertical mounting rails on the rack).

**Warning Statement 1006—Chassis Warning for Rack-Mounting and Servicing**

To prevent bodily injury when mounting or servicing this unit in a rack, you must take special precautions to ensure that the system remains stable. The following guidelines are provided to ensure your safety:

- This unit should be mounted at the bottom of the rack if it is the only unit in the rack.
- When mounting this unit in a partially filled rack, load the rack from the bottom to the top with the heaviest component at the bottom of the rack.
- If the rack is provided with stabilizing devices, install the stabilizers before mounting or servicing the unit in the rack.

Step 1

Slide the power supply end of the chassis onto the bottom-support rails that are installed on the rack.

Be sure that the sides of the chassis by the power supplies clip into the chassis stops on the bottom-support rails and the front-mount brackets come in contact with the rack. See the figure.

Note If the bottom-support rails are extended a long distance, they can bend outwards slightly when you install the chassis and the chassis stops at the far end of the rails might not fit into the end of the chassis. If this happens, press the side rails toward the sides of the chassis so that the chassis stops can go inside the chassis and hold it in place on the rack.

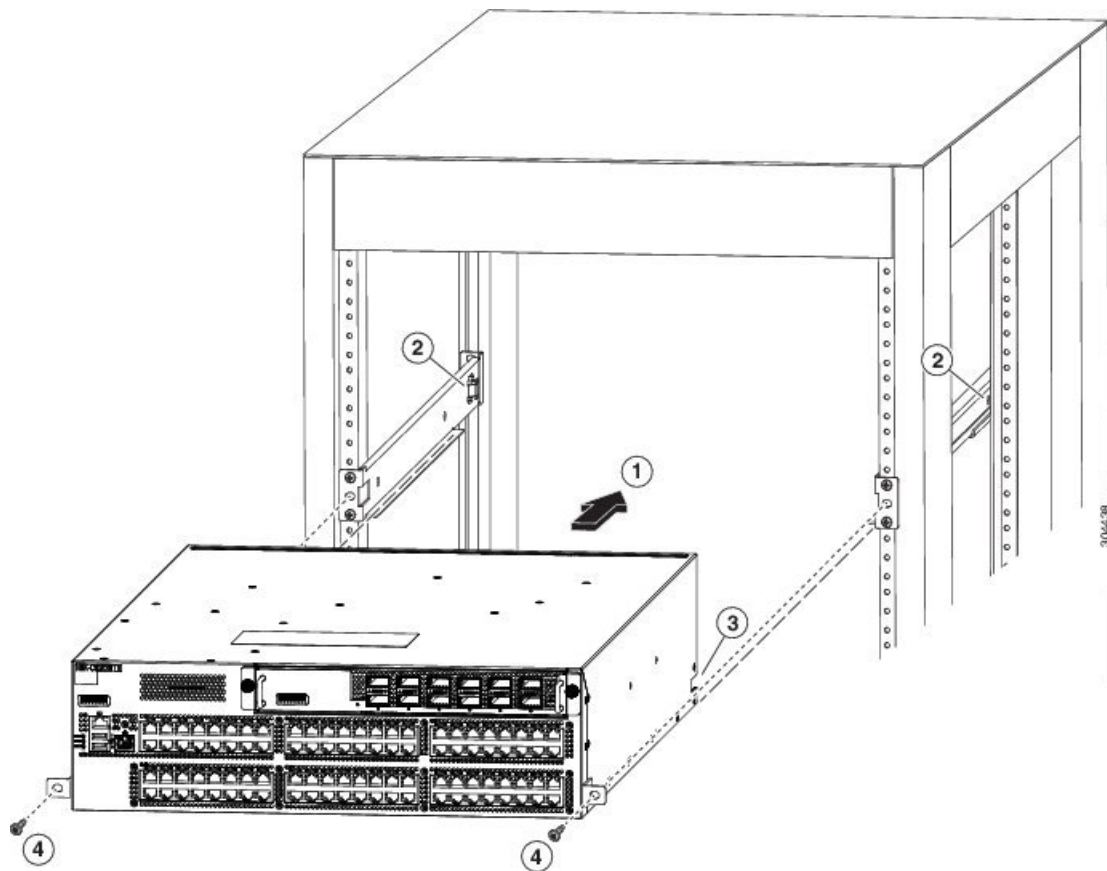

1	Slide the power-supply end of the chassis onto the bottom-support rails so that the chassis locks onto the chassis stops at the end of the rails.	3	Receiving hole on each side of the chassis for the chassis stops on the bottom-support rails.
2	Chassis stops for holding the chassis (positioned by the aisle required for the fan and power supply modules).	4	Customer-supplied rack-mount screw (M6 x 10 mm screw or other screw appropriate for the rack) used to secure each side of the chassis to the rack.

Step 2 Use a customer-supplied rack-mount screw (an M6 x 10 mm screw or other appropriate screw for the rack) to attach each of the two mounting brackets on the chassis to the rack and tighten each screw to the appropriate torque setting for the screw (for M6 x 10 mm screws, use 40 in-lbs [4.5 N·m] of torque).

Grounding the Chassis

The switch chassis is automatically grounded when you properly install the switch in a grounded rack with metal-to-metal connections between the switch and rack.



Note Provide an electrical conducting path between the product chassis and the metal surface of the enclosure or rack in which it is mounted or to a grounding conductor. To ensure electrical continuity, use thread-forming type mounting screws that remove any paint or non-conductive coatings and establish a metal-to-metal contact. Remove any paint or other non-conductive coatings on the surfaces between the mounting hardware and the enclosure or rack. Clean the surfaces and apply an antioxidant before installation.

Ground the chassis, which is required if the rack is not grounded. Attach a customer-supplied grounding cable. Attach the cable to the chassis grounding pad and the facility ground.



Warning Statement 1024—Ground Conductor

This equipment must be grounded. To reduce the risk of electric shock, never defeat the ground conductor or operate the equipment in the absence of a suitably installed ground conductor. Contact the appropriate electrical inspection authority or an electrician if you are uncertain that suitable grounding is available.



Warning Statement 1046—Installing or Replacing the Unit

To reduce risk of electric shock, when installing or replacing the unit, the ground connection must always be made first and disconnected last.

Before you begin

Before you can ground the chassis, you must have a connection to the earth ground for the data center building.

Step 1 Use a wire-stripping tool to remove approximately 0.75 inch (19 mm) of the covering from the end of the grounding wire. We recommend 6-AWG wire for the U.S. installations.

Step 2 Insert the stripped end of the grounding wire into the open end of the grounding lug. Use a crimping tool to crimp the lug to the wire, see the figure. Verify that the ground wire is securely attached to the grounding lug by attempting to pull the wire out of the crimped lug (tug test).

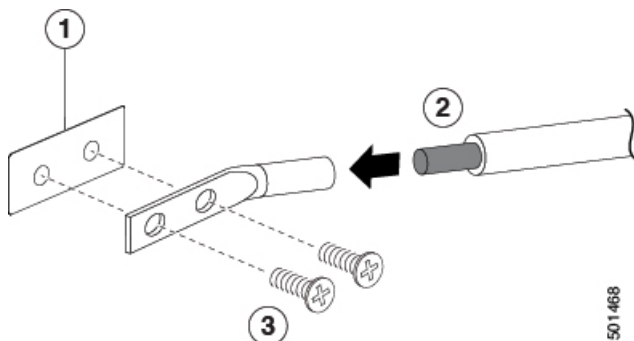

1	Chassis grounding pad	3	2 M4 screws are used to secure the grounding lug to the chassis
---	-----------------------	---	---

2	Grounding cable, with 0.75 in. (19 mm) of insulation that is stripped from one end, which is inserted into the grounding lug and crimped in place		
---	---	--	--

Step 3 Secure the grounding lug to the chassis grounding pad with two M4 screws, see figure 1. Tighten the screws to 11 to 15 in-lb (1.24 to 1.69 Nm) of torque.

Step 4 Prepare the other end of the grounding wire and connect it to the facility ground.

Starting the Switch

Start the switch by connecting it to its dedicated power source. If you need $n+n$ redundancy, connect each power supply in a switch to a different power source.



Note This equipment is designed to boot up in less than 30 minutes, dependent on its neighboring devices being fully up and running.

Before you begin

- The switch must be installed and secured to a rack or cabinet.
- The switch must be adequately grounded.
- The rack must be close enough to the dedicated power source so that you can connect the switch to the power source by using the designated power cables.
- You have the designated power cables for the power supplies that you are connecting to the dedicated power sources.



Note Depending on the outlet receptacle on your AC power distribution unit, you might need an optional jumper power cord to connect the switch to your outlet receptacle.

- The switch is not connected to the network (this includes any management or interface connections).
- The fan and power supply modules are fully secured in their chassis slots.

Step 1 For any AC power supply, do this:

- Using the recommended AC power cable for your country or region, connect one end to the AC power supply.
- Connect the other end of the power cable to the AC power source.

Step 2 For any HVAC/HVDC power supply, connect it to a power source like this:

- Using the recommended high voltage power cable for your country or region, connect the Anderson Power Saf-D-Grid connector on the power cable to the power receptacle on the power supply. Make sure that the connector clicks when fully pushed into the receptacle.

- b) Connect the other end of the power cable to a power source.
- When connecting to an HVAC power source, insert the plug in a receptacle for the HVAC power source.
 - When connecting to an HVDC power source, do this:
 1. Verify that the power is turned off at a circuit breaker for the power source terminals.
 2. Remove the nuts from each of the terminal posts for the power supply.
 3. Place the power cable negative-wire terminal ring on the negative terminal for the power source and secure them with a terminal nut.
 4. Place the power cable positive-wire terminal ring on the positive terminal for the power source and secure them with a terminal nut.
 5. Place the power cable ground-wire terminal ring on the ground terminal for the power source and secure them with a terminal nut.
 6. If there is a safety cover for the power source terminals, place and secure it over the terminals to avoid an electrical shock hazard.
 7. Turn on the power at the power source circuit breaker.

Step 3 For any DC power supply, do this:

- a) Turn off the circuit breaker for the power source to avoid an electrical shock hazard.
- b) Verify that the power cable wires from the power source are connected to a connector block.
- c) Insert the connector block into the receptacle on the power supply. Make sure that the connector block clicks when fully inserted in the receptacle and does not pull out.
- d) If there is a safety cover for the terminals, place and secure it over the terminals to avoid an electrical shock hazard.
- e) Turn on the power at the circuit breaker for the DC power source.

Step 4 Verify that the power supply LED is on and green.

Step 5 Listen for the fans; they should begin operating when the power supply is powered.

Step 6 After the switch boots, verify that these LEDs are lit:

- On the fan modules, the Status (STA or STS) LED is green.
If a fan module Status LED is not green, try reinstalling the fan module.
- After initialization, the switch chassis Status (labeled as STA or STS) LED is green.

Step 7 Verify that the system software has booted and the switch has initialized without error messages.

A setup utility automatically launches the first time that you access the switch and guides you through the basic configuration. For instructions on how to configure the switch and check module connectivity, see the appropriate Cisco Nexus 9000 Series configuration guide.



CHAPTER 4

Connecting the Switch to the ACI Fabric

- [ACI Fabric Topology, on page 29](#)
- [Preparing to Connect to Other Devices, on page 30](#)
- [Connecting Leaf Switches to APICs, on page 31](#)
- [Connecting Leaf Switches to Spine Switches, on page 33](#)
- [Installing a Gigabit Ethernet module \(GEM\), on page 34](#)
- [Replacing an Existing Switch in the ACI Fabric, on page 34](#)
- [Setting Up an Optional Console Interface, on page 34](#)
- [Setting Up an Optional Management Connection, on page 35](#)
- [Maintaining Transceivers and Optical Cables, on page 35](#)

ACI Fabric Topology

The ACI fabric topology includes the following major components:

- Application Centric Infrastructure Controller (APIC) appliance (cluster of APICs)
- Leaf switches (for switch compatibility, please see the [data sheets](#)).
- Spine switches (for switch compatibility, please see the [data sheets](#)).

For additional information, please see the [Cisco APIC Installation, Upgrade, and Downgrade Guide](#).



Note To prevent sub-optimal forwarding between endpoints, connect every leaf switch in the fabric to every spine switch in the same fabric.

As shown in the following figure, each APIC is connected to one or two leaf switches and each leaf switch should be connected to every spine switch in the same fabric.

Figure 2: Connections Between APIC Clusters, Leaf Nodes, and Spine Nodes

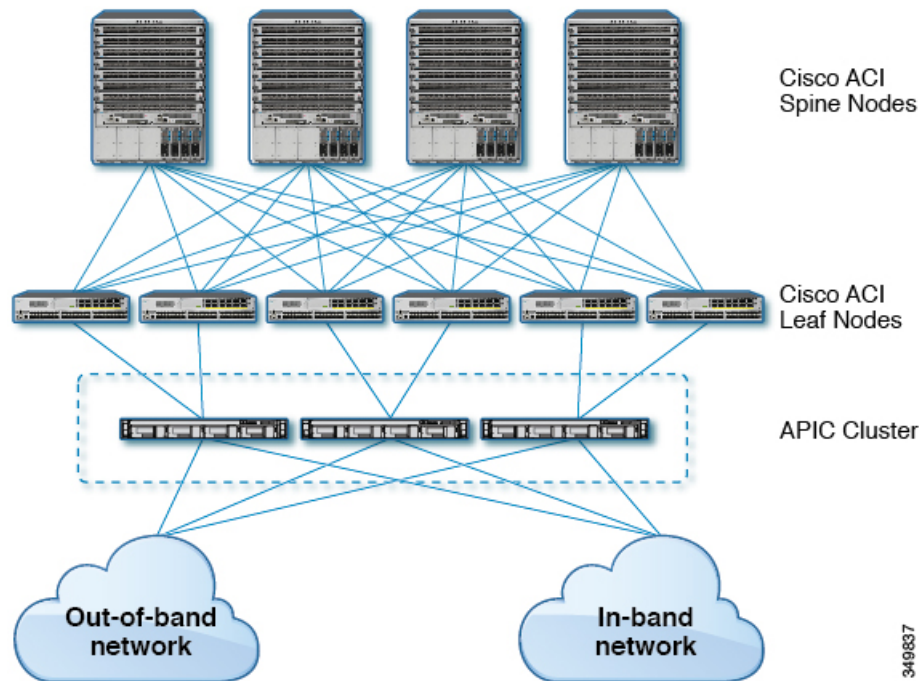

Preparing to Connect to Other Devices

When preparing to connect the fabric devices, consider the following for each type of interface, and gather all of the required equipment before making the connections:

- Cabling type required for each interface type
- Distance limitations for each signal type
- Additional interface equipment required



Note When running power and data cables in overhead or subfloor cable trays, we strongly recommend that you locate power cables and other potential noise sources as far away as practical from network cabling that terminates on Cisco equipment. In situations where long parallel cable runs cannot be separated by at least 3.3 feet (1 meter), we recommend that you shield any potential noise sources by housing them in a grounded metallic conduit.

The optical transceivers that are not already assembled to their cables come separate from their cables. To prevent these transceivers and their cables from being damaged, we recommend that you keep the transceivers disconnected from their cables when installing them in ports and then insert the optical cable into the transceiver. When removing transceivers from ports, remove their cables before removing the transceivers.

To maximize the effectiveness and life of your transceivers and optical cables, do the following:

- Wear an ESD-preventative wrist strap that is connected to an earth ground whenever handling transceivers. The switch is typically grounded when you install transceivers and provides an ESD port to which you

can connect your wrist strap. If you cannot find an ESD port, connect the wrist strap to an earth ground (such as the grounding connection for the chassis).

- Do not remove or insert a transceiver more often than necessary. Repeated removals and insertions can shorten its useful life.
- Keep the transceivers and fiber-optic cables clean and dust free to maintain high signal accuracy and to prevent damage to the connectors. Attenuation (loss of light) increases with contamination and should be kept below 0.35 dB.
 - Clean these parts before installing them to prevent dust from scratching the fiber-optic cable ends.
 - Clean the connectors regularly; the required frequency of cleaning depends upon the environment. In addition, clean connectors if they are exposed to dust or accidentally touched. Both wet and dry cleaning techniques can be effective; refer to your site's fiber-optic connection cleaning procedures.
 - Do not touch the ends of connectors. Touching the ends can leave fingerprints and cause other contamination.
- Inspect routinely for dust and damage. If you suspect damage, clean and then inspect fiber ends under a microscope to determine if damage has occurred.

Connecting Leaf Switches to APICs

You must downlink one or two (recommended for redundancy) Cisco Nexus 9300 platform ACI-mode leaf switches to each Application Policy Infrastructure Controller (APIC) in your ACI fabric. The type of virtual interface card (VIC) installed on the APIC determines the types of interface cables that you can use to connect the leaf switches to the APICs.

- The **VIC 1225T** module supports copper connectors, copper cables, and switches with copper downlink ports (such as: Cisco Nexus 93108TC-FX switch).
- The **VIC 1225** module supports optical transceivers, optical cables, and switches with optical downlink ports (such as: Cisco Nexus 93600CD-GX switch).
- The **VIC 1455** module supports optical transceivers, optical cables, and switches with optical downlink ports (such as: Cisco Nexus 93600CD-GX switch).



Note Breakout ports cannot be used for Cisco APIC connectivity.

Before you begin

The APIC and leaf switches in the fabric must be fully installed in their racks and grounded.

Step 1

Connect an interface cable to one of the two to four ports on the virtual interface card (VIC) installed on the APIC. If the cable is not already assembled to its transceivers, insert the transceiver into the VIC port and then connect the optical interface cable to the transceiver.

- For a **VIC 1225T** 10GBASE-T copper module, use 10GBASE-T cables with RJ-45 connectors.

- For a **VIC 1225** optical module, use one of the following sets of transceivers and cables:
 - Cisco 10GBASE-LR transceivers (SFP-10G-LR) supporting a link length of up to 6.1 miles (10 km)
 - Cisco 10GBASE-SR transceivers (SFP-10G-SR) supporting the following link lengths:
 - Using 2000 MHz MMF (OM3) for up to 984 feet (300 m)
 - Using 4700 MHz MMF (OM4) for up to 1312 feet (400 m)
 - Cisco SFP+ Active Optical Cables (SFP-10G-AOC x M [where $x=1, 3, 5, 7$ for lengths in meters])
 - Cisco SFP+ Twinax Cables (SFP-H10GB-CU x M [where $x=7$ for lengths in meters])
- For a **VIC 1455** SFP28 module, 10-Gigabit only, use one of the following sets of transceivers and cables:
 - Cisco 10GBASE-LR transceivers (SFP-10G-LR) supporting a link length of up to 6.1 miles (10 km)
 - Cisco 10GBASE-SR transceivers (SFP-10G-SR) supporting the following link lengths:
 - Using 2000 MHz MMF (OM3) for up to 984 feet (300 m)
 - Using 4700 MHz MMF (OM4) for up to 1312 feet (400 m)
 - Cisco SFP+ Active Optical Cables (SFP-10G-AOC x M [where $x=1, 2, 3, 5, 7, 10$ for lengths in meters])
 - Cisco SFP+ Twinax Cables (SFP-H10GB-CU x M [where $x=1, 2, 3, 5, 7, 10$ for lengths in meters])

Note The VIC 1455 has 4 ports, port-1, port-2, port-3, and port-4 from left to right.

- All ports must have the same speed, either 10-Gigabit or 25-Gigabit.
- Port-1 and port-2 is one pair, corresponding to eth2-1 on APIC and port-3 and port-4 is another pair, corresponding to eth2-2 on APIC. Only one connection is allowed for each pair. For example, you can connect one cable to either port-1 or port-2, and connect another cable to either port-3 or port-4 (**please do not connect two cables on any pair**).

To determine which transceivers, adapters, and cables support this switch, see the [Cisco Transceiver Modules Compatibility Information](#) document.

To see the transceiver specifications and installation information, see [Transceiver Module Installation Guides](#).

Step 2 Connect the other end of the interface cable to a downlink port on a leaf switch.

- For a Cisco 10GBASE-LR or -SR transceiver and cable, insert the transceiver into a downlink optical port on a leaf switch before connecting the cable to the transceiver.
- For Cisco SFP+ Active Optical Cables, insert the transceiver on the cable into a downlink optical port on a leaf switch.
- For a 10GBASE-T copper cable, insert the RJ-45 connector on the cable into a downlink BASE-T port on a leaf switch.

Note To determine which transceivers, adapters, and cables support this switch, see the [Cisco Transceiver Modules Compatibility Information](#) document.

Connecting Leaf Switches to Spine Switches

For optimal forwarding between endpoints, you must connect each leaf switch to every spine switch in the same ACI fabric.

To determine which transceivers, adapters, and cables support this switch, see the [Cisco Transceiver Modules Compatibility Information](#) document.

To see the transceiver specifications and installation information, see [Transceiver Module Installation Guides](#).



Warning **Statement 1055**—Class 1/1M Laser

Invisible laser radiation is present. Do not expose to users of telescopic optics. This applies to Class 1/1M laser products.



Warning **Statement 1056**—Unterminated Fiber Cable

Invisible laser radiation may be emitted from the end of the unterminated fiber cable or connector. Do not view directly with optical instruments. Viewing the laser output with certain optical instruments, for example, eye loupes, magnifiers, and microscopes, within a distance of 100 mm, may pose an eye hazard.

Before you begin

- The leaf and spine switches in the fabric (such as: N9k-C9364C, N9K-C9332C, N9K-C9316D-GX, and N9K-C9332D-GX2B) must be fully installed in their racks and grounded.
- If there are modular switches in the fabric, their ACI-mode line cards must already be installed. The line cards can be of the following types:
 - 32-port 100-Gigabit (such as: N9K-X9732C-EX)
 - 36-port 100-Gigabit (such as: N9K-X9736C-FX)
 - 16-port 400-Gigabit (such as: N9K-X9716D-GX)



Note You cannot include NX-OS line cards in the same chassis when running in ACI mode.



Note Multiple uplinks from a leaf switch to a spine switch is supported. A symmetrical topology is recommended so that all devices have equal access to resources.

-
- Step 1** For the transceivers with removable cables, make sure that the transceivers are separated from their interface cables.
- Step 2** Insert the appropriate transceiver into an active uplink port on the leaf switch.
- Step 3** Insert the same type of transceiver in the spine switch port on the line card.
- Step 4** For transceivers with removable cables, insert the interface cable into the open end of each of those transceivers.
- Step 5** Repeat Steps 1 through 4 for each spine switch in the ACI fabric.
The leaf switch is connected to each spine switch in the ACI fabric.
- Step 6** Repeat Steps 1 through 5 for each leaf switch in the ACI fabric.
Each leaf switch in the ACI fabric is connected to each spine switch in the network,
-

The fabric automatically implements Equal Cost Multi-Pathing (ECMP) and enables all links. You do not need to configure the links.

Installing a Gigabit Ethernet module (GEM)

- Step 1** Clear the switch's current configuration by using the `setup-clean-config` command.
- Step 2** Power off the switch by disconnecting the power.
- Step 3** Replace the current GEM card with the new GEM card.
- Step 4** Power on the switch.
-

Replacing an Existing Switch in the ACI Fabric

To replace an existing switch in the ACI fabric, see "Upgrading the Switch Hardware" in the [Cisco APIC Installation and ACI Upgrade and Downgrade Guide](#).

Setting Up an Optional Console Interface

You can optionally set up a console interface for performing the initial configuration of the switch. To do this, use the interface cable provided in the accessory kit to connect the switch to your console device. You can connect the console port on the switch to a modem. If you do not connect it to a modem, make the connection either before powering up the switch or after completing the boot process for the switch.

Before you begin

The console device must support VT100 terminal emulations and asynchronous transmissions.

- Step 1** Configure the terminal emulator program to match each of the following default port characteristics:
- 9600 baud
 - 8 data bits

- 1 stop bit
- No parity

Step 2 Insert the RJ-45 connector on the interface cable found in the accessory kit into the RS-232 port on the switch and insert the DB-9 connector on the other end of the cable to the serial port on the console device.

What to do next

You can now perform the initial configuration for the switch (see the *Cisco ACI Getting Started Guide*).

Setting Up an Optional Management Connection

You can optionally set up an out-of-band management connection for monitoring and troubleshooting purposes. To do this, depending on your switch, you connect either the RJ-45 management port or the SFP management port on the switch to an external hub, switch, or router.

Before you begin

To prevent an IP address conflict, you must complete the initial configuration for the switch and establish an IP address before you create the management connection.

Step 1 Connect the interface cable to a management port on the switch.

Step 2 Connect the other end of the cable to an external hub, switch, or router.

Maintaining Transceivers and Optical Cables

Transceivers and fiber-optic cables must be kept clean and dust free to maintain high signal accuracy and prevent damage to the connectors. Contamination increases attenuation (loss of light) and should be below 0.35 dB.

Consider these maintenance guidelines:

- Transceivers are static sensitive. To prevent ESD damage, wear an ESD-preventative wrist strap that is connected to the grounded chassis.
- Do not remove and insert a transceiver more often than is necessary. Repeated removals and insertions can shorten its useful life.
- Keep all optical connections covered when not in use. Clean them before using to prevent dust from scratching the fiber-optic cable ends.
- Do not touch the ends of connectors. Touching the ends can leave fingerprints and cause other contamination.

- Clean the connectors regularly; the required frequency of cleaning depends upon the environment. In addition, clean connectors if they are exposed to dust or accidentally touched. Both wet and dry cleaning techniques can be effective; refer to the fiber-optic connection cleaning procedures for your site.
- Inspect routinely for dust and damage. If you suspect damage, clean and then inspect fiber ends under a microscope to determine if damage has occurred.



CHAPTER 5

Replacing Modules

- [Replacing the Uplink Module, on page 37](#)
- [Replacing a Fan Module During Operations, on page 38](#)
- [Replacing a Power Supply Module, on page 40](#)

Replacing the Uplink Module

You must shut down the switch before replacing the M6PQ, M6PQ-E, or M12PQ uplink module.

-
- Step 1** Power off the switch by removing the power cables from both of the power supplies installed in the switch.
- Step 2** Verify that both LEDs on each power supply are off and that all of the other switch LEDs are off. If any LEDs are on, look for a power supply that is still powered on and remove its power cable.
- Step 3** Remove the cables from each of the ports on the uplink module. Be sure to label each cable for future reference.
- Step 4** Unscrew both captive screws on the front of the module.
- Step 5** Holding both handles on the front of the module, slide the module out of the slot.
- Caution** To prevent electrostatic discharge (ESD) damage to the module electronics, do not touch the electrical connectors on the back side of the module. Also, to prevent any damage to the electrical connectors, prevent them touching anything that can bend or break them.
- Step 6** Place the module on an antistatic surface or inside an antistatic bag. If possible, repack the module in its shipping materials for safe shipping or storage.
- Step 7** Remove the replacement module from its packing materials and place it on an antistatic surface. Hold the module by its two handles and do not touch the electrical connectors on its backside. Also, to protect the electrical connectors, avoid letting them come in contact with anything other than the electrical connectors inside the chassis.
- Step 8** Holding the replacement module by its two handles, position the module with the electrical components on its backside facing the open uplink-module slot.
- Step 9** Slide the module all the way into the chassis until its front side comes in contact with the chassis. For the last 0.2 inches (0.5 cm), carefully mount the module onto the chassis connectors by pushing more firmly, but do not force the module if it does not move further (excessive force can damage the connectors).

Note If you are not able to push the module all the way into the slot, carefully slide the module out of the slot and check its electrical connectors for damage. If damaged, contact Cisco Technical Assistance for help. If undamaged, repeat Step 6 to reinstall the module.

Step 10 Screw in both captive screws on the front of the module to secure the module to the chassis. Tighten each screw to 8 in-lb (0.9 N·m).

Step 11 Verify that the Status (STS) LED turns on and becomes amber.

Step 12 Reconnect each of the APIC-connection cables and verify that the LED for each port becomes green.

Under each set of two uplink ports, there is an Active (ACT) LED that indicates whether the ports are active for this switch. Connect cables to only the active ports.

Replacing a Fan Module During Operations

There must always be at least one fan module installed in the chassis to maintain the designed airflow. You can remove one fan module temporarily to replace it with another fan module within two minutes to avoid a shutdown, but if the replacement fan module is not available, leave the original fan module in the chassis.

All fan and power supply modules must have the same airflow direction or else an error can occur with the switch overheating and shutting down. You can determine the airflow direction of a fan module by the color of the stripe on the front of the module. If the fan module has a blue stripe for port-side exhaust airflow, the power supplies must have blue or gray coloring for the same airflow direction. If the fan module has a burgundy stripe for port-side intake airflow, the power supplies must have burgundy or green coloring for the same airflow direction. To avoid over heating the switch, make sure that the fan modules are positioned in one of the following ways:

- For port-side exhaust airflow with blue coloring, position the fan modules in a cold aisle.
- For port-side intake airflow with burgundy coloring, position the ports in a cold aisle.

Before you begin

Before you can replace a fan module, ensure that the following conditions exist:

- There are two functioning fan modules in the other fan slots. In order to replace a fan module during operations, there must be two fan modules circulating air in the chassis at all times. The other fan module is redundant and can be replaced.
- The replacement fan module must have the same airflow direction as the other modules in the chassis.

If you must replace the fan module during operations and the above conditions are not met, leave the fan module that you need to replace in the chassis to preserve the designed airflow until you have the required module.

Step 1 Remove the fan module that you need to replace as follows:

- a) Verify that the fan modules that you are not replacing each have a lit Status (STS) LED (see the following figure for the location of the LED). If you are replacing a fan module during operations, the other two fan modules must be operating.

Note If you are replacing the fan module while the chassis is not operating, you can skip this step.

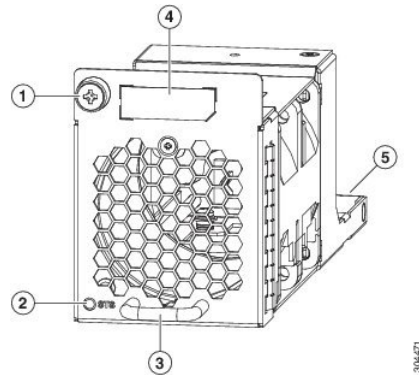

1	Captive screw	4	Colored stripe specifying the airflow direction (burgundy for the port-side intake direction or blue for the port-side exhaust direction)
2	Status (STS) LED	5	Electrical connectors on the backside.
3	Handle		

b) Pull the fan module handle to slide the module out of the chassis.

Caution To prevent electrostatic discharge (ESD) damage to the module electronics, do not touch the electrical connectors on the back side of the module. Also, to prevent any damage to the electrical connectors, prevent them touching anything that can bend or break them.

c) Place the removed module on an antistatic surface or in an antistatic bag. If possible, repack the module in its packing materials for safe shipping or storage.

Step 2

Follow these steps to replace the missing fan module within two minutes to avoid a shutdown.

a) Remove the replacement fan module from its packing materials and place it on an antistatic surface.

Hold the module by its handle and do not touch the electrical connectors on its backside. Also, to protect the electrical connectors, avoid letting them come in contact with anything other than the electrical connectors inside the chassis.

b) Verify that you have the right fan module for the chassis. The correct fan module has one of the following part numbers:

- N9K-C9300-FAN2-B (port-side exhaust airflow direction and a blue stripe)
- N9K-C9300-FAN2 (port-side intake airflow direction and a burgundy stripe)

Note Be sure that the airflow direction of the new fan module matches the airflow direction of the other fan and AC power supply modules already installed in the chassis. Port-side intake airflow is indicated with burgundy or green coloring, and port-side exhaust airflow is indicated with blue or gray coloring.

c) Position the fan module in front of the open fan slot (be sure that the backside of the module with the electrical connectors is positioned to enter the slot first) and slide the module all the way into the chassis until its front side comes in contact with the chassis. For the last 0.2 inches (0.5 cm), carefully mount the module onto the chassis connectors by pushing more firmly, but do not force the module if it does not move further (excessive force can damage the connectors).

Note If you are not able to push the module all the way into the slot, carefully slide the module out of the slot and check its electrical connectors for damage. If damaged, contact Cisco Technical Assistance for help. If undamaged, repeat this step to reinstall the module.

d) Verify that the STS LED turns on and becomes green.

If the STS LED does not turn on, slide the module out of the chassis, and visually check the electrical connectors on the back side of the chassis for damage. If damaged, contact Cisco Technical Assistance for help. If undamaged, repeat the previous step to reinstall the module.

e) Secure the fan module to the chassis by screwing in the captive screw to the chassis. Tighten the screw to 5 to 7 in-lb (0.56 to 0.79 N·m).

Replacing a Power Supply Module

The switch requires two power supplies for redundancy. With one power supply providing the necessary power for operations, replace the other power supply during operations as long as the new power supply has the same airflow direction as the other modules in the chassis.

Replace a power supply with another supported power supply that has the same power source type as the other installed power supply. Additionally, the airflow direction of the power supply must match or conform to the airflow direction of the installed fan modules. For the airflow direction used by the switch, see the coloring of the fan modules.

Removing an AC Power Supply

To remove an AC power supply, disconnect the power cable and remove the module from the chassis.

Before you begin

- To replace a power supply during operations, you must have a functioning power supply providing power to the switch while you replace the other power supply. If there is only one power supply installed in the switch and you need to replace it, install the new power supply in the open slot and power it up before removing the original power supply.
- Ensure that the chassis is grounded. For grounding instructions, see [Grounding the Chassis, on page 24](#).

Step 1 Disconnect the power cord from the power receptacle on the power supply to be removed. Verify that the LED turns off.

Note The LED might be on and amber colored. This indicates that the input power has been disconnected.

Step 2 Remove the power supply from the chassis by pushing and holding its thumb latch to the left and pulling the power supply part way out of the chassis.

Step 3 Place your other hand under the power supply to support it while you slide it out of the chassis.

Either place the power supply on an antistatic surface or pack it in its packing materials.

What to do next

You are ready to install the replacement power supply.

Removing a DC Power Supply

You can remove one power supply while the other one provides power to the switch.

To disconnect the power supply from its power cables, shut off the power from the power source and disconnect the connector for the power cables.

-
- Step 1** Turn off the circuit breaker for the power feed to the power supply that you are replacing.
Verify that the LEDs turn off on the power supply that you are removing.
- Step 2** Remove the power cable from the power supply. Do this:
- Step 3** Grasp the power supply handle while pressing the release latch towards the power supply handle.
- Step 4** Pull the power supply out of the bay.
-

What to do next

You are ready to install a DC power supply in the open slot.

Installing an AC Power Supply

You can replace one power supply while the other one provides power to the switch.

Before you begin

- The power supply that you are installing must be capable of using the same airflow direction as the fan trays installed in the same switch. It must use the same type of power source as the other power supply installed in the same switch. (Do not mix AC and DC power supplies in the same switch.)



Note DC power supplies with green coloring have the same port-side intake airflow direction as the power supplies with red coloring, and DC power supplies with gray coloring have the same port-side exhaust airflow direction as the power supplies with blue coloring. If the power supply that you are replacing has a different color handle than the replacement power supply, verify that it has or will have the same airflow direction as the other modules in the switch.

- An AC power source must be within reach of the power cable that will be used with the replacement power supply. If you are using $n+n$ power redundancy, there must be a separate power source for each power supply installed in the chassis. Otherwise, only one power source is required.
- There must be an earth-ground connection to the chassis that you are installing the replacement module. Typically, the chassis is grounded by its metal-to-metal connection with a grounded rack. If you need to ground the chassis, see [Grounding the Chassis, on page 24](#).

-
- Step 1** Holding the replacement power supply with one hand underneath the module and the other hand holding the handle, turn the power supply so that its release latch is on the right side. Align the back end of the power supply (the end with the electrical connections) to the open power supply slot. Carefully slide the power supply all the way into the slot until it clicks into place.
- Note** If the power supply does not fit into the open slot, turn the module over, before sliding it carefully into the open slot.
- Step 2** Test the installation by trying to pull the power supply out of the slot without using the release latch. If the power supply does not move out of place, it is secured in the slot. If the power supply moves, carefully press it all the way into the slot until it clicks into place.
- Step 3** Attach the power cable to the electrical inlet on the front of the power supply.
- Step 4** Verify that the other end of the power cable is attached to the appropriate power source for the power supply.
- Note** Depending on the outlet receptacle on your power distribution unit, install the optional jumper cable to connect the switch to your outlet receptacle.
- Step 5** Verify that the power supply is operational by making sure that the power supply  LED is green.
-

Installing a DC Power Supply

This topic is for installing the 48-V DC power supply into switch chassis.

You can replace one power supply while the other one provides power to the switch.

Before you begin

- The circuit breaker for the DC power source for the power supply must be turned off.
- The power supply that you are installing must be capable of using the same airflow direction as the fan trays installed in the same switch.
- A DC power source must be within reach of the power cable that will be used with the replacement power supply. If you are using $n+n$ power redundancy, there must be a separate power source for each power supply installed in the chassis. Otherwise, only one power source is required.
- There must be an earth-ground connection to the chassis that you are installing the replacement module. Typically, the chassis is grounded by its metal-to-metal connection to a grounded rack. If you need to ground this chassis by another means, see [Grounding the Chassis, on page 24](#).
- We recommend 8-AWG wire for DC installation in the U.S.
- All DC power supplies have reverse polarity protection. When you inadvertently connect the input power (+) to the DC PSU's – terminal and the input power – to the DC PSU's (+) terminal, the PSU will not be damaged and will operate fine after the input power feeds are correctly wired.

-
- Step 1** Holding the replacement power supply with one hand underneath the module and the other hand holding the handle, turn the power supply so that its release latch is on the right side. Align the back end of the power supply (the end with the electrical connections) to the open power supply slot. Carefully slide the power supply all the way into the slot until it clicks into place.
- Note** If the power supply does not fit into the open slot, turn the module over. Carefully slide it into the open slot.
- Step 2** If the DC power cables and a grounding cable are already connected to an electrical connector block, insert the block into the power receptacle on the power supply.
- Step 3** Turn on the circuit breaker for the DC power source connected to the power supply.
- Step 4** Verify that the power supply is operational by making sure that the power supply  LED is green.
-

Wiring a 48 V DC Electrical Connector Block

You must connect the ground, negative, and positive DC power cables to a connector block in order to connect the power cables to a 48 V DC power supply.



Note The recommended wire gauge is 8 AWG. The minimum wire gauge is 10 AWG.



Warning **Statement 342**—Before Connecting to System Power Supply

High touch/leakage current – Permanently connected protective earth ground is essential before connecting to system power supply.



Warning **Statement 1024**—Ground Conductor

This equipment must be grounded. To reduce the risk of electric shock, never defeat the ground conductor or operate the equipment in the absence of a suitably installed ground conductor. Contact the appropriate electrical inspection authority or an electrician if you are uncertain that suitable grounding is available.

Before you begin

You must turn off the circuit breaker for the DC power cables that you are connecting to prevent electrocution.

- Step 1** Verify that the circuit breaker for the power feed to the replacement power supply is turned off.
- Step 2** Remove the DC power connector block from the power supply by doing the following:
- Push the orange plastic button on the top of the connector block inward toward the power supply.
 - Pull the connector block out of the power supply.
- Step 3** Strip 0.6 inches (15 mm) of insulation off the DC wires that you are using.
- Step 4** Orient the connector as shown in the following figure with the orange plastic button on top.

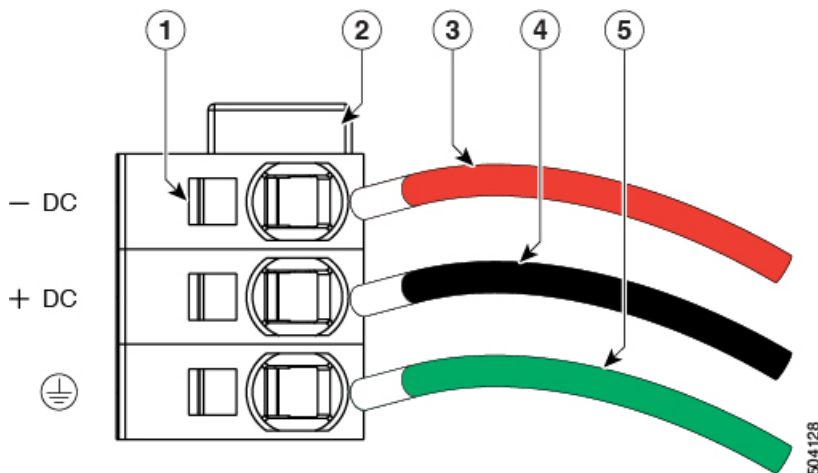

1	Wire retainer lever	4	-48V (+DC) cable
2	Orange plastic button on top of the connector	5	Grounding cable (8 AWG recommended)
3	-48V (-DC) cable		

- Step 5** Use a small screwdriver to depress the spring-loaded wire retainer lever on the lower spring-cage wire connector. Insert your green (ground) wire into the aperture and then release the lever.
- Step 6** Use a small screwdriver to depress the spring-loaded wire retainer lever on the upper spring-cage wire connector. Insert your red (DC negative) wire into the aperture and then release the lever.
- Step 7** Use a small screwdriver to depress the spring-loaded wire retainer lever on the middle spring-cage wire connector. Insert your black (DC positive) wire into the aperture and then release the lever.
- Step 8** Insert the connector block back into the power supply. Make sure that your black (DC positive) wire aligns with the power supply label, "+ DC".
- Step 9** Verify that the other ends of the cables are attached to the DC power source and ground. You are then ready to turn on the DC power source.



APPENDIX **A**

Rack Specifications

- [Overview of Racks, on page 45](#)
- [General Requirements for Cabinets and Racks, on page 45](#)
- [Requirements Specific to Standard Open Racks, on page 46](#)
- [Requirements Specific to Perforated Cabinets, on page 46](#)
- [Cable Management Guidelines, on page 46](#)

Overview of Racks

Install the switch in these types of cabinets and racks, assuming an external ambient air temperature range of 0 to 104°F (0 to 40°C):

- Standard perforated cabinets
- Solid-walled cabinets with a roof fan tray (bottom to top cooling)
- Standard open racks



Note If you are using an enclosed cabinet, we recommend one of the thermally validated types, either standard perforated or solid-walled with a fan tray.



Note We do not recommend using racks that have obstructions (such as power strips). The obstructions could impair access to field-replaceable units (FRUs).

General Requirements for Cabinets and Racks

The cabinet or rack must meet these requirements:

- Standard 19-inch (48.3 cm) (two- or four-post EIA cabinet or rack, with mounting rails that conform to English universal hole spacing per section 1 of ANSI/EIA-310-D-1992). For more information, see [Requirements Specific to Perforated Cabinets, on page 46](#).

- The minimum vertical rack space requirement per chassis is:
 - For a one RU (rack unit) switch, 1.75 inches (4.4 cm)
 - For a one and a half RU (rack unit) switch, 2.63 (6.68 cm)
 - For a two RU (rack unit) switch, 3.5 inches (8.8 cm)
 - For a three RU (rack unit) switch, 5.25 inches (13.3 cm)
- The width between the rack-mounting rails must be at least 17.75 inches (45.0 cm) if the rear of the device is not attached to the rack. For four-post EIA racks, this measurement is the distance between the two front rails.

Four-post EIA cabinets (perforated or solid-walled) must meet these requirements:

- The minimum spacing for the bend radius for fiber-optic cables should have the front-mounting rails of the cabinet offset from the front door by a minimum of 3 inches (7.6 cm).
- The distance between the outside face of the front mounting rail and the outside face of the back mounting rail should be 23.0 to 30.0 inches (58.4 to 76.2 cm) to allow for rear-bracket installation.

Requirements Specific to Standard Open Racks

If you are mounting the chassis in an open rack (no side panels or doors), ensure that the rack meets these requirements:

- The minimum vertical rack space per chassis must be equal to the rack unit (RU) of the chassis. One rack unit is equal to 1.75 inches (4.4 cm).
- The distance between the chassis air vents and any walls should be 2.5 inches (6.4 cm).

Requirements Specific to Perforated Cabinets

A perforated cabinet has perforations in its front and rear doors and side walls. Perforated cabinets must meet these requirements:

- The front and rear doors must have at least a 60 percent open area perforation pattern, with at least 15 square inches (96.8 square cm) of open area per rack unit of door height.
- The roof should be perforated with at least a 20 percent open area.
- The cabinet floor should be open or perforated to enhance cooling.

The Cisco R Series rack conforms to these requirements.

Cable Management Guidelines

To help with cable management, allow additional space in the rack above and below the chassis to make it easier to route all of the fiber optic or copper cables through the rack.



APPENDIX **B**

System Specifications

- [Environmental Specifications, on page 47](#)
- [Switch Dimensions, on page 47](#)
- [Switch and Module Weights and Quantities, on page 48](#)
- [Transceiver and Cable Specifications, on page 48](#)
- [Switch Power Input Requirements, on page 48](#)
- [Power Specifications, on page 49](#)
- [Power Cable Specifications, on page 50](#)
- [Regulatory Standards Compliance Specifications, on page 52](#)

Environmental Specifications

Environment		Specification
Temperature	Ambient operating temperature	32 to 104°F (0 to 40°C)
	Ambient nonoperating	−40 to 158°F (−40 to 70°C)
Relative humidity	Nonoperating	5 to 95%
	Operating	5 to 90%
Altitude	Operating	0 to 13,123 feet (0 to 4,000 meters)

Switch Dimensions

Switch	Width	Depth	Height
Cisco Nexus 93128TX	17.5 inches (44.5 cm)	22.5 inches (57.1 cm)	5.3 inches (13.3 cm) (3 RU)

Switch and Module Weights and Quantities

Component	Weight per Unit	Quantity
Cisco Nexus 93128TX Chassis (N9K-C93128TX)	32.56 lb (14.8 kg)	1
Uplink Module	—	1
– M6PQ and M6PQ-E	2.0 lb (0.9 kg)	
– M12PQ	3.12 lb (1.4 kg)	
Fan Modules	—	3 (2 for operation, 1 for redundancy)
– Port-side exhaust (blue) (N9K-C9300-FAN2-B)	1.14 lb (0.5 kg)	
– Port-side intake (burgundy) (N9K-C9300-FAN2)	1.14 lb (0.5 kg)	
Power Supply Module	—	2 (1 for operation, one for redundancy)
– 1200-W AC port-side exhaust (burgundy) (N9K-PAC-1200W-B)	2.64 lb (1.2 kg)	
– 1200-W AC port-side intake (blue) (N9K-PAC-1200W)	2.64 lb (1.2 kg)	
– 930-W DC port-side exhaust (gray) (UCS-PSU-6332-DC)	2.42 lb (1.1 kg)	
– 930-W DC port-side intake (green) (UCSC-PSU-930WDC)	2.42 lb (1.1 kg)	

Transceiver and Cable Specifications

To see the transceiver specifications and installation information, see <https://www.cisco.com/c/en/us/support/interfaces-modules/transceiver-modules/products-device-support-tables-list.html>.

Switch Power Input Requirements

This table lists the typical amount of power that the switch consumes. It also lists the maximum amount of power that you must provision for the switch and power supply for peak conditions.



Note Some power supplies have capabilities that are greater than the maximum power requirements for a switch. To determine the power consumption characteristics for the switch, use the typical and maximum requirements that are listed here.

Switch	Typical Power Consumption (AC or DC)	Maximum Power Consumption (AC or DC)	Heat Dissipation Requirement
Cisco Nexus 93128TX	582 W	853 W	2910.556 BTUs per hour

Power Specifications

Power specifications include the specifications for each type of power supply module.

1200-W AC Power Supply Specifications

These specifications apply to the following 1200-W AC power supplies:

- N9K-PAC-1200W
- N9K-PAC-1200W-B

Characteristic	Specification
AC input voltage	Nominal range: 100-120 VAC, 200-240 VAC
AC input frequency	Nominal range: 50 to 60 Hz (Range: 47-63 Hz)
Maximum AC input current	10 A at 100-120 VAC 8 A at 200-240 VAC
Maximum output power per power supply	800 W at 100-120 VAC 1200 W at 200-240 VAC
Maximum hold-up time	12 ms at 650 W
Power supply output voltage	12 VDC
Power supply standby voltage	12 VDC
Efficiency rating	Climate Savers Platinum Efficiency (80Plus Platinum certified)
Form factor	RSP1

930-W DC Power Supply (Port-Side Intake) Specifications

These specifications apply to the 930-W DC (UCSC-PSU-930WDC) port-side intake power supplies.

Characteristic	Specification
DC input voltage range	Nominal range: -48 to -60 VDC nominal (Range: -40 to -60 VDC)
Maximum DC input current	23 A at -48 VDC
Maximum input W	1104 W
Maximum output power per power supply	930 W
Maximum inrush current	35 A (sub-cycle duration)

Characteristic	Specification
Maximum hold-up time	8 ms at 930 W
Power supply output voltage	12 VDC
Power supply standby voltage	12 VDC
Efficiency rating	Greater than 92% at 50% load
Form factor	RSP1

930-W DC Power Supply (Port-Side Exhaust) Specifications

These specifications apply to the 930-W DC (UCS-PSU-6332-DC) power supplies.

Characteristic	Specification
Maximum DC input current	23 A at -48 VDC
Maximum input W	1104 W
Maximum output power per power supply	930 W
Maximum inrush current	35 A at +35° Celcius
Maximum hold-up time	8 ms at 50 % load
Power supply output voltage	12 VDC
Power supply standby voltage	12 VDC
Efficiency rating	Climate Savers Platinum Efficiency (80Plus Platinum certified)
Form factor	1U

Power Cable Specifications

These sections show the power cables that you can order and use with this switch.

Power Cable Specifications for AC Power Supplies

Locale	Power Cord Part Number	Cord Set Description
	CAB-C13-C14-2M	Power Cord Jumper, C13-C14 Connectors, 6.6 feet (2.0 m)
	CAB-C13-CBN	Cabinet jumper power cord, 250 VAC, 10 A, C14-C13 connectors, 2.3 feet (0.7 m)

Locale	Power Cord Part Number	Cord Set Description
Argentina	CAB-250V-10A-AR	250 V, 10 A, 8.2 feet (2.5 m)
Australia	CAB-9K10A-AU	250 VAC, 10 A, 3112 plug, 8.2 feet (2.5 m)
Brazil	CAB-250V-10A-BR	250 V, 10 A, 6.9 feet (2.1 m)
European Union	CAB-9K10A-EU	250 VAC, 10 A, CEE 7/7 plug, 8.2 feet (2.5 m)
India	CAB-IND-10A	10 A, 8.2 feet (2.5 m)
India	CAB-C13-C14-2M-IN	Power Cord Jumper, C13-C14 Connectors, 6.6 feet (2.0 m)
India	CAB-C13-C14-3M-IN	Power Cord Jumper, C13-C14 Connectors, 9.8 feet (3.0 m)
Israel	CAB-250V-10A-IS	250 V, 10 A, 8.2 feet (2.5 m)
Italy	CAB-9K10A-IT	250 VAC, 10 A, CEI 23-16/VII plug, 8.2 feet (2.5 m)
Japan	CAB-C13-C14-2M-JP	Power Cord Jumper, C13-C14 Connectors, 6.6 feet (2.0 m)
North America	CAB-9K12A-NA	125 VAC, 13 A, NEMA 5-15 plug, 8.2 feet (2.5 m)
North America	CAB-AC-L620-C13	NEMA L6-20-C13, 6.6 feet (2.0 m)
North America	CAB-N5K6A-NA	200/240V, 6A, 8.2 feet (2.5 m)
Peoples Republic of China	CAB-250V-10A-CN	250 V, 10 A, 8.2 feet (2.5 m)
South Africa	CAB-250V-10A-ID	250 V, 10 A, 8.2 feet (2.5 m)
Switzerland	CAB-9K10A-SW	250 VAC, 10 A, MP232 plug, 8.2 feet (2.5 m)
United Kingdom	CAB-9K10A-UK	250 VAC, 10 A, BS1363 plug (13 A fuse), 8.2 (2.5 m)
All except Argentina, Brazil, and Japan	NO-POWER-CORD	No power cord included with switch

DC Power Cable Specifications

Power Supply	Power Cord	Cord Set Description
UCSC-PSU-930WDC (port-side intake airflow)	(customer supplied)	8 AWG insulated cable (10 AWG minimum) for ea
UCS-PSU-6332-DC (port-side exhaust airflow)	CAB-48DC-40A-8AWG	8-AWG cable with 3-pin keyed power supply conn (power source connection)

Power Supply	Power Cord	Cord Set Description
All except Argentina, Brazil, and Japan	NO-POWER-CORD	No power cord included with switch

Regulatory Standards Compliance Specifications

This table lists the regulatory standards compliance for the switch.

Table 1: Regulatory Standards Compliance: Safety and EMC

Specification	Description
Regulatory compliance	Products should comply with CE Markings according to directives 2004/108/EC and 2006/95/EC.
Safety	<ul style="list-style-type: none"> • CAN/CSA-C22.2 No. 60950-1 Second Edition • CAN/CSA-C22.2 No. 62368-1-19 Third Edition • ANZI/UL 60950-1 Second edition • IEC 62368-1 • EN 62368-1 • AS/NZS 62368-1 • GB4943 • UL 62368-1
EMC: Emissions	<ul style="list-style-type: none"> • 47CFR Part 15 (CFR 47) Class A • AS/NZS CISPR22 Class A • CISPR22 Class A • EN55022 Class A • ICES003 Class A • VCCI Class A • EN61000-3-2 • EN61000-3-3 • KN22 Class A • CNS13438 Class A

Specification	Description
EMC: Immunity	<ul style="list-style-type: none">• EN55024• CISPR24• EN300386• KN 61000-4 series
RoHS	The product is RoH-6 compliant with exceptions for leaded-ball grid-array (BGA) balls and lead press-fit connectors.



APPENDIX C

LEDs

- [Switch Chassis LEDs, on page 55](#)
- [Uplink Module LEDs, on page 56](#)
- [Fan Module LEDs, on page 56](#)
- [Power Supply LEDs, on page 56](#)

Switch Chassis LEDs

The BCN, STS, and ENV, LEDs are located on the left side of the front of the switch. The port LEDs appear as triangles pointing up or down to the nearest port.

LED	Color	Status
BCN	Flashing blue	The operator has activated this LED to identify this switch in the chassis.
	Off	This switch is not being identified.
STS	Green	The switch is operational.
	Flashing amber	The switch is booting up.
	Amber	Temperature exceeds the minor alarm threshold.
	Red	Temperature exceeds the major alarm threshold.
	Off	The switch is not receiving power.
ENV	Green	Fans and power supply modules are operational.
	Amber	At least one fan or power supply module is not operating.
(port)	Green	Port admin state is 'Enabled', SFP is present and the interface is connected (that is, cabled, and the link is up).
	Amber	Port admin state is 'Disabled, or the SFP is absent, or both.
	Off	Port admin state is 'Enabled' and SFP is present, but interface is not connected.

Uplink Module LEDs

The Status (STS) LED is located on the left side of the uplink module. There is an ACT LED located below each two uplink ports. Next to each ACT LED are two triangular port LEDs that point to the top or bottom to identify their port as being the top or bottom port.

LED	Color	Status
STS	Green	This module is operational.
	Red	Temperature is not operational.
	Off	The module is not receiving power.
ACT	On (white)	The two ports above this LED are enabled.
	Off	The two ports above this LED are not enabled.
(port)	Green	The port is connected with a transceiver or other connector.
	Off	The port is not connected.

Fan Module LEDs

The fan module status LED is located below the air holes on the front of the module.

LED	Color	Status
Status	Green	The fan module is operational.
	Red	The fan module is not operational (fan is probably not functional).
	Off	Fan module is not receiving power.

Power Supply LEDs

The power supply LEDs are located on the right portion of the power supply. Combinations of states indicated by the **OK** and **Fault** LEDs signify the status for the module as shown in this table.

OK LED	FAIL or FAIL/ID LED	Status
Green	Off	Power supply is on and outputting power to the switch.
Flashing green	Off	Power supply is connected to a power source but not outputting power to the switch. The power supply may not be properly installed in the chassis.
Off	Off	Either all the installed power supplies are not receiving power or an uninstalled power supply is not receiving power.

OK LED	FAIL or FAIL/ID LED	Status
Off	Flashing amber	Power supply is operating but a warning condition has occurred—possibly one of these conditions: <ul style="list-style-type: none">• High temperature• High power• Slow power supply fan• Low voltage• Power supply is installed in the chassis but was disconnected from the power source.
Off	Flashing amber (10 seconds) then amber	Power supply is installed without a connection to a power source.
Off	Amber	Power supply failure—possibly one of these conditions: <ul style="list-style-type: none">• Over voltage• Over current• Over temperature• Power supply fan failure



APPENDIX **D**

Additional Kits

- [Rack Mount Kit N9K-C9300-RMK](#), on page 59

Rack Mount Kit N9K-C9300-RMK

The following table lists and illustrates the contents for the 2-RU rack-mount kit (N9K-C9300-RMK).

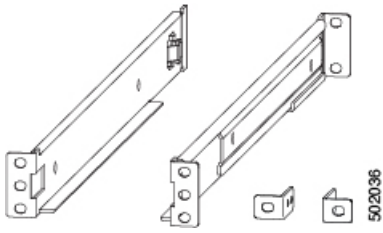
Illustration	Description	Quantity
	Rack-mount kit <ul style="list-style-type: none">• Bottom support rails (2)• Front-mount brackets (2)	1



APPENDIX **E**

Site Preparation and Maintenance Records

- [Site Preparation Checklist, on page 61](#)
- [Contact and Site Information, on page 62](#)
- [Chassis and Module Information, on page 63](#)

Site Preparation Checklist

Planning the location and layout of your equipment rack or cabinet is essential for successful switch operation, ventilation, and accessibility.

The following table lists the site planning tasks that we recommend that you complete before you install the switch. Your completion of each task ensures a successful switch installation.

Planning Activity	Verification Time and Date
Space evaluation:	
Space and layout	
Floor covering	
Impact and vibration	
Lighting	
Physical access	
Maintenance access	
Environmental evaluation:	
Ambient temperature	
Humidity	
Altitude	
Atmospheric contamination	
Airflow	

Planning Activity	Verification Time and Date
Power evaluation:	
Input power type	
Power receptacles	
Receptacle proximity to the equipment	
Dedicated (separate) circuits for power redundancy	
UPS for power failures	
Grounding: proper wire gauge and lugs	
Circuit breaker size	
Grounding evaluation:	
Data center ground	
Cable and interface equipment evaluation:	
Cable type	
Connector type	
Cable distance limitations	
Interface equipment (transceivers)	
EMI evaluation:	
Distance limitations for signaling	
Site wiring	
RFI levels	

Contact and Site Information

Use the following worksheet to record contact and site information for the installation.

Contact person	
Contact phone	

Contact e-mail	
Building/site name	
Data center location	
Floor location	
Address (line 1)	
Address (line 2)	
City	
State/Provence	
Contact person	
ZIP/postal code	
Country	

Chassis and Module Information

Use the following worksheet to record information about the switch.

Contract number	
Chassis serial number	
Product number	

Use the following worksheet to record network-related information.

Switch IP address	
Switch IP netmask	
Hostname	
Domain name	
IP broadcast address	
Gateway/router address	
DNS address	

Use the following worksheet to record information about the modules in the switch.

Module Slot	Module Type	Module Serial Number	Notes
Uplink module			

Module Slot	Module Type	Module Serial Number	Notes
Fan module 1			
Fan module 2			
Fan module 3			
Power Supply 1			
Power Supply 2			