



Prepare for Installation



Note The images in this chapter are only for representational purposes, unless specified otherwise. The chassis' actual appearance and size may vary.



Warning **Statement 1071**—Warning Definition

IMPORTANT SAFETY INSTRUCTIONS

This warning symbol means danger. You are in a situation that could cause bodily injury. Before you work on any equipment, be aware of the hazards involved with electrical circuitry, and be familiar with standard practices for preventing accidents. Use the statement number provided at the end of each warning to locate its translation in the translated safety warnings that accompanied this device.

SAVE THESE INSTRUCTIONS

- [Safety Guidelines, on page 1](#)
- [Compliance and Safety Information, on page 2](#)
- [Laser Safety, on page 3](#)
- [Energy Hazard, on page 3](#)
- [Preventing Electrostatic Discharge Damage, on page 3](#)
- [Cautions and Regulatory Compliance Statements for NEBS, on page 4](#)
- [Installation Guidelines, on page 4](#)
- [Procure Tools and Equipment, on page 5](#)
- [Prepare Your Location , on page 6](#)
- [Prepare Yourself , on page 8](#)
- [Prepare Rack for Chassis Installation, on page 9](#)
- [Clearance Requirements, on page 9](#)

Safety Guidelines

Before you perform any procedure in this document, review the safety guidelines in this section to avoid injuring yourself or damaging the equipment. The following guidelines are for your safety and to protect the equipment. Because the guidelines do not include all hazards, be constantly alert.

- Keep the work area clear, smoke and dust-free during and after installation. Do not allow dirt or debris to enter into any laser-based components.
- Do not wear loose clothing, jewelry, or other items that could get caught in the switch or other associated components.
- Cisco equipment operates safely when used in accordance with its specifications and product-usage instructions.
- Be sure to power down a fixed configuration PDU or modular configuration power shelf before removing it from the chassis.
- If potentially hazardous conditions exist, do not work alone.
- Take care when connecting multiple units to the supply circuit so that wiring is not overloaded.
- This equipment must be grounded. Never defeat the ground conductor or operate the equipment in the absence of a suitably installed ground conductor. Contact the appropriate electrical inspection authority or an electrician if you are uncertain about whether suitable grounding is available.
- When installing or replacing the unit, the ground connection must always be made first and disconnected last.
- To prevent personal injury or damage to the chassis, never attempt to lift or tilt the chassis using the handles on modules (such as power supplies, fans, or cards); these types of handles are not designed to support the weight of the unit.
- Hazardous voltage or energy is present on the backplane when the system is operating. Use caution when servicing.
- The rack stabilizing mechanism must be in place, or the rack must be bolted to the floor before you slide out the unit for servicing. Failure to stabilize the rack may cause the rack to tip over.

Compliance and Safety Information

The Cisco Nexus 9800 Series Switches are designed to meet the regulatory compliance and safety approval requirements. For detailed safety information, see [Regulatory Compliance and Safety Information](#).



Warning **Statement 1005**—Circuit Breaker

This product relies on the building's installation for short-circuit (overcurrent) protection.

- Ensure that the protective devices are rated not greater than 30A max (North America); 32A max (Europe); 32A max (UK) (AC/HVAC/HVDC) (AHF-2DC-6300W), 100A max (LVDC) (DHF-2DC-4400W).
-

Laser Safety



Warning Invisible laser radiation may be emitted from disconnected fibers or connectors. Do not stare into beams or view directly with optical instruments.



Warning Invisible laser radiation is present. Do not expose to users of telescopic optics. This applies to Class 1/1M laser products.



Warning Pluggable optical modules comply with IEC 60825-1 Ed. 3 and 21 CFR 1040.10 and 1040.11 with or without exception for conformance with IEC 60825-1 Ed. 3 as described in Laser Notice No. 56, dated May 8, 2019.

Energy Hazard

The switch can be configured for a DC power source. Do not touch terminals while they are live. Observe the following warning to prevent injury.



Warning **Statement 1086**—Power Terminals

Hazardous voltage or energy may be present on power terminals. Always replace cover when terminals are not in service. Be sure uninsulated conductors are not accessible when cover is in place.

Preventing Electrostatic Discharge Damage

Many components can be damaged by static electricity. Not exercising the proper electrostatic discharge (ESD) precautions can result in intermittent or complete component failures. To minimize the potential for ESD damage, always use an ESD-preventive antistatic wrist strap (or ankle strap) and ensure that it makes adequate skin contact.



Note Check the resistance value of the ESD-preventive strap periodically. The measurement should be 1–10 megohms.

Before you perform any of the procedures in this guide, attach an ESD-preventive strap to your wrist and connect the leash to the chassis.

Cautions and Regulatory Compliance Statements for NEBS

The NEBS-GR-1089-CORE regulatory compliance statements and requirements are discussed in this section.



Warning The intrabuilding port(s) of the equipment or subassembly, which is the management Ethernet port, must use shielded intrabuilding cabling/wiring that is grounded at both ends. Statement 7003



Warning The intrabuilding port(s) of the equipment or subassembly, which is the management Ethernet port, must not be metallically connected to interfaces that connect to the OSP or its wiring. These interfaces are designed for use as intrabuilding interfaces only (Type 2 or Type 4 ports as described in GR-1089-CORE) and require isolation from the exposed OSP cabling. The addition of Primary Protectors is not sufficient protection in order to connect these interfaces metallically to OSP wiring. Statement 7005



Warning This equipment shall be connected to AC mains provided with a surge protective device (SPD) at the service equipment complying with NFPA 70, the National Electrical Code (NEC). Statement 7012



Warning This equipment is suitable for installations utilizing the Common Bonding Network (CBN). Statement 7013



Warning The battery return conductor of this equipment shall be treated as (DC-I). Statement 7016



Warning This equipment is suitable for installation in Network Telecommunications Facilities. Statement 8015



Warning This equipment is suitable for installation in locations where the NEC applies. Statement 8016

Installation Guidelines

Before installing the chassis, ensure that the following guidelines are met:

- Site is properly prepared so that there is sufficient room for installation and maintenance.
- Operating environment is within the ranges that are listed in Environment and Physical specifications. For more details on environmental requirements, see [Cisco Nexus 9800 Series Switches Data Sheet](#).
- Chassis is mounted at the bottom of the rack if it is the only unit in the rack.

- When mounting the chassis in a partially filled rack, load the rack from the bottom to the top with the heaviest component at the bottom of the rack.
- If the rack is provided with stabilizing devices, install the stabilizers before mounting or servicing the chassis in the rack.
- Airflow around the chassis and through the vents is unrestricted.
- Cabling is away from sources of electrical noise, such as radios, power lines, and fluorescent lighting fixtures. Make sure that the cabling is safely away from other devices that might damage the cables.
- Each port must match the wave-length specifications on each end of the cable, and the cable must not exceed the stipulated cable length.



Note Cisco 9800 Series switches function in operating temperatures of up to 40°C at sea level. For every 300 meters (1000 ft) elevation upto 1800 meters (6000 ft), the maximum temperature is reduced by 1°C. For more details on environmental requirements, see [Cisco Nexus 9800 Series Switches Data Sheet](#).

Procure Tools and Equipment

Obtain these necessary tools and equipment for installing the chassis:

- Number 1 and number 2 Phillips screwdrivers with torque capability to rack-mount the chassis.
- 3/16-inch flat-blade screwdriver.
- Tape measure and level.
- ESD wrist strap or other grounding device.
- Antistatic mat or antistatic foam.
- Two-hole ground lug (1).
- Grounding cable (2 AWG recommended), sized according to local and national installation requirements; the required length depends on the proximity of the switch to proper grounding facilities.
- A crimping tool specified by the lug manufacturer that is large enough to accommodate the girth of the lug.
- Wire-stripping tool.
- A maximum of 70 rack mount screws can be used based on your rack selection.

Rack Mount and Accessory Kits

Accessory Kit

Accessory kit (N9K-C9800-IN-KIT) includes the following:

Table 1: Accessory Kit

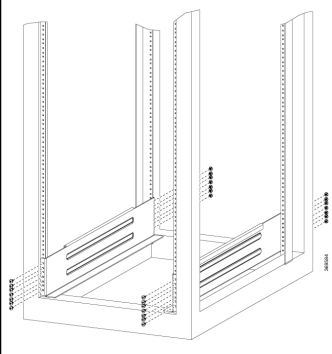
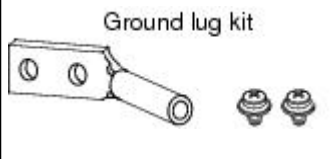
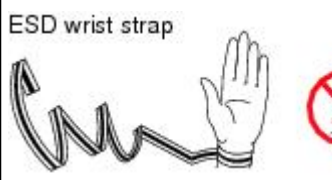
Illustration	Description	Quantity
	Rack mount kit (N9K-C9800-AR-KIT): <ul style="list-style-type: none"> • Support rails are non-adjustable • Set the vertical support rack rails at 32" pitch 	1
	Ground lug kit <ul style="list-style-type: none"> • Two-hole lug (1) • 1/4"-20 Phillips pan-head screws (2) 	1
	ESD wrist strap (disposable)	1

More Hardware Components

If you purchased this product through a Cisco reseller, you might receive more contents in your kit, such as documentation, hardware, and power cables.

The shipped cables depend on your specification when placing an order. See the *Power Supply Power Cord Specifications* section for information on the available power cords.

If you notice any discrepancies or damage, send the following information to your customer service representative by email:

- Invoice number of the shipper (see the packing slip)
- Model and serial number of the missing or damaged unit
- Description of the problem and how it affects the installation
- Photos of the damage to external packaging, internal packaging, and product

Prepare Your Location

This section illustrates how the building that houses the chassis must be properly grounded to the earth ground.



Note Unless specified otherwise, the image is only for representational purposes. The rack's actual appearance and size may vary.



Note This image is only for representational purposes. Your grounding requirement depends on your building.

Figure 1: Building with Rack Room Connected to Earth Ground

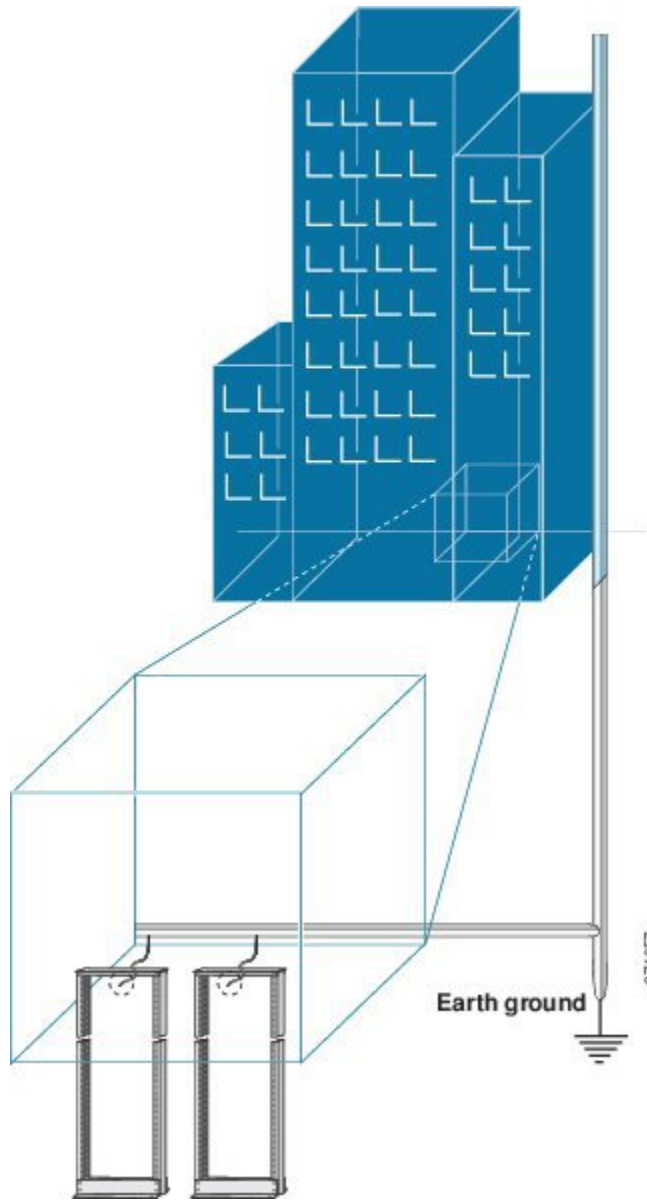

Prepare Yourself

This section illustrates how to prepare yourself before removing the chassis from the sealed antistatic bag. The figures show how to cuff the ESD strap around the wrist and the ground cord that connects the cuff to the ground. ESD wrist straps are the primary means of controlling static charge on personnel.

Figure 2: Wearing the ESD Strap

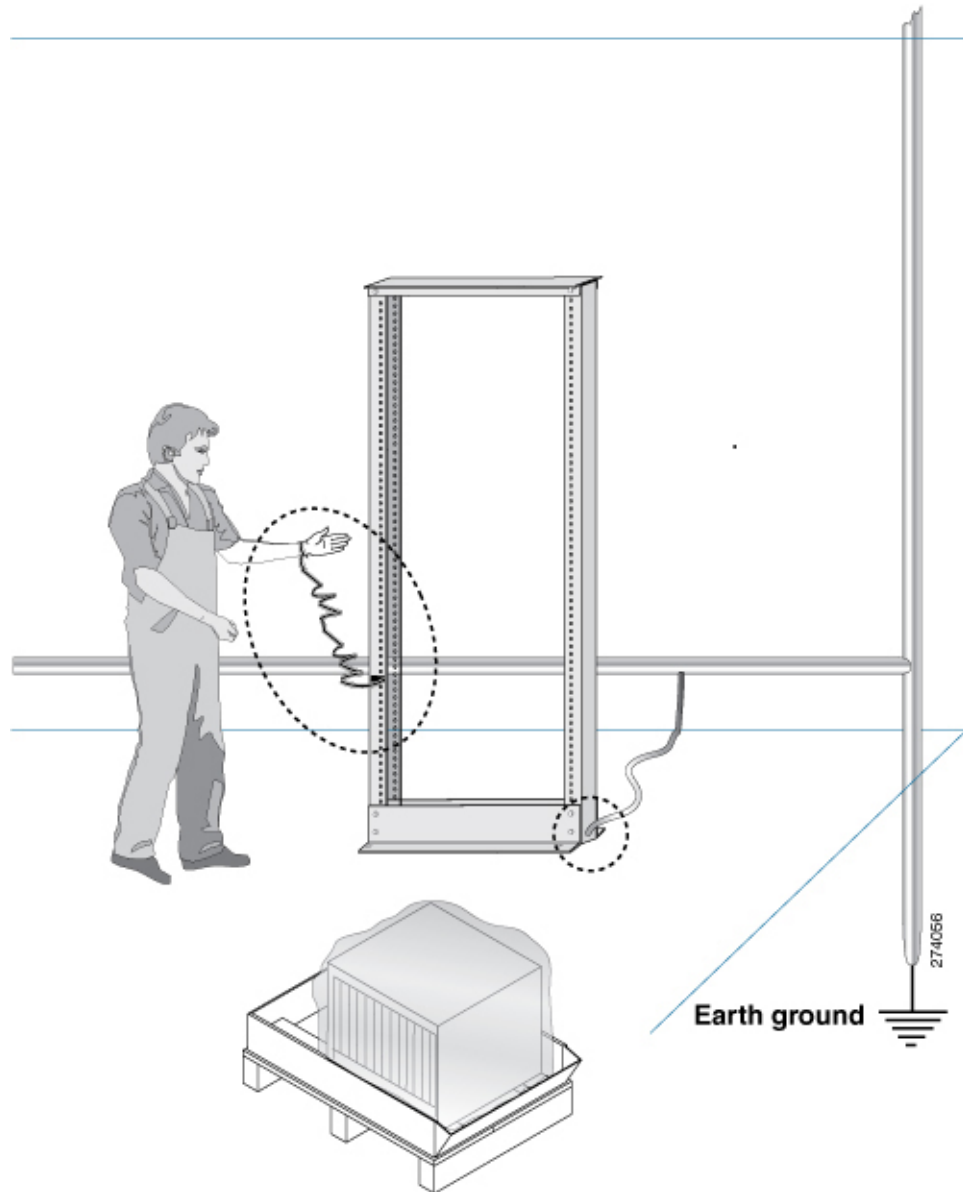

Prepare Rack for Chassis Installation

Install the switch on a standard 19 inch, Electronic Industries Alliance (EIA) rack with mounting rails that conform to English universal hole spacing according to Section 1 of the ANSI/EIA-310-D-1992 standard.

The spacing between the posts of the rack must be (EIA-310-D-1992 19-inch rack compatible) wide enough to accommodate the width of the chassis.

Before you move the chassis or mount the chassis into the rack, we recommend that you do the following:

Procedure

Step 1 Place the rack at the location where you plan to install the chassis.

Step 2 (Optional) Secure the rack to the floor.

To bolt the rack to the floor, a floor bolt kit (also called an anchor embedment kit) is required. For information on bolting the rack to the floor, consult a company that specializes in floor mounting kits (such as Hilti; see [Hilti.com](https://www.hilti.com) for details). Make sure that floor mounting bolts are accessible, especially if annual retorquing of bolts is required.

Note Ensure that the rack in which the chassis is being installed is grounded to earth ground.

Clearance Requirements

To ensure adequate airflow, we recommended that you maintain a minimum clearance distance always, as mentioned in the following figure.

Following figure shows the clearances required for installation of the switch.

Figure 3: Clearances Required Around the Chassis

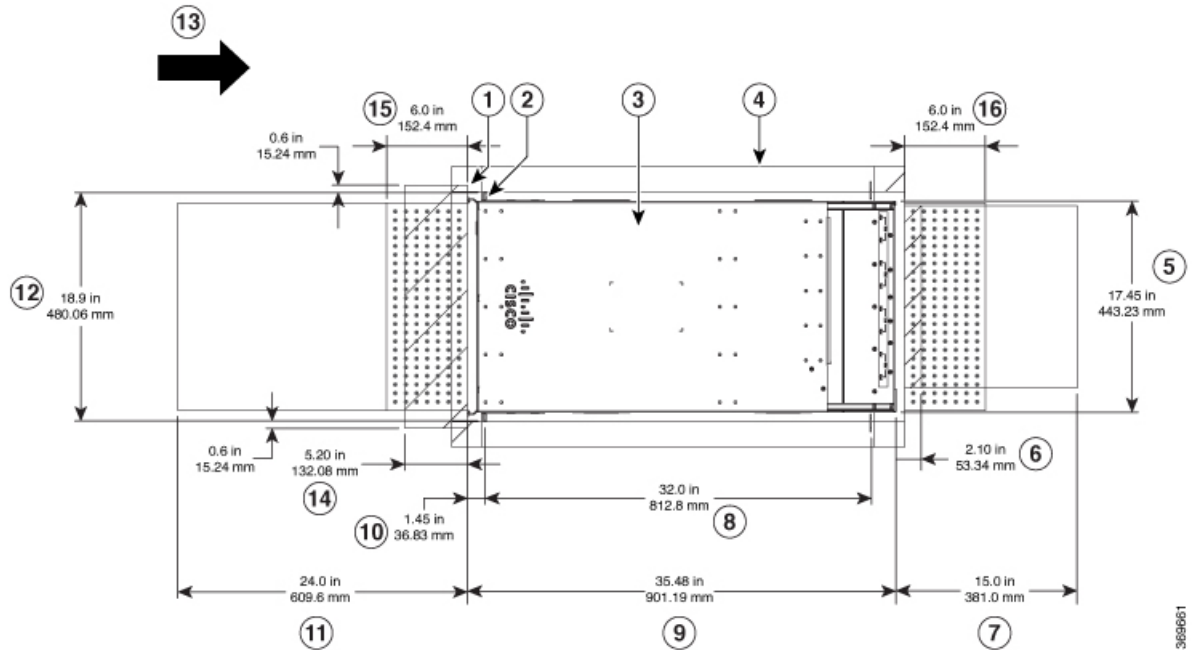

(1) Vertical rack post	(8) Mounting depth of rack vertical rails
(2) Vertical rack rail	(9) Chassis depth
(3) Chassis	(10) Depth from the vertical rack rail to the front of the chassis
(4) Outside of the rack (no clearance required)	(11) Front service area for the line card replacement
(5) Rear chassis width	(12) Front chassis width
(6) Clearance required for the fan tray handle at the rear	(13) Airflow direction
(7) Rear service area for the fan tray and fabric card replacement	

Following figure shows the clearances required for the cable management of the switch.

Figure 4: Clearances Required Around the Chassis Door

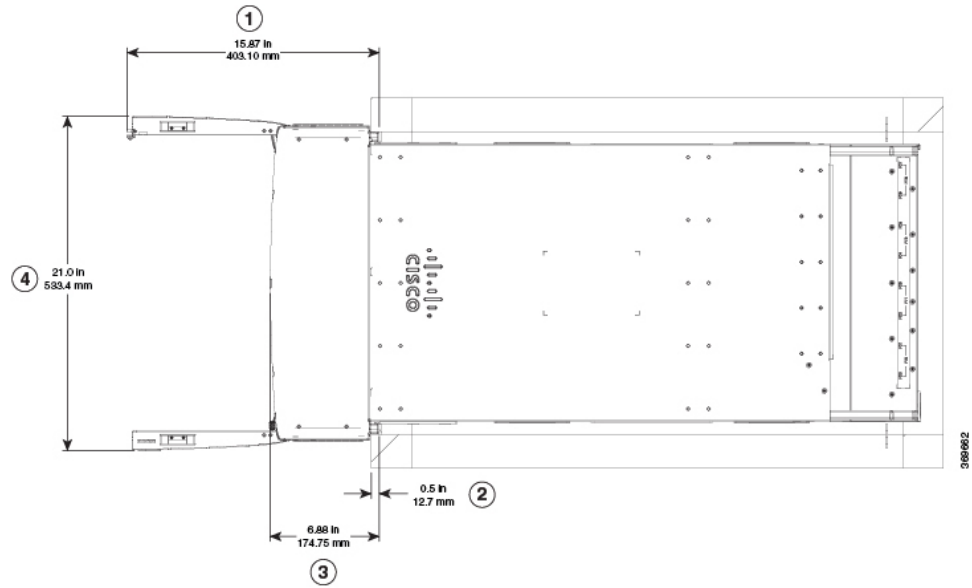

(1) Overall door width on side (in an open position)	(3) Depth of cable management
(2) Maximum vertical rack rail setback, when filters are installed on the chassis	(4) Overall door depth on front (in an open position)

