



Replace Chassis Components

- [Replace Chassis Components, on page 1](#)
- [Replace Chassis Door Foam Air Filters, on page 1](#)
- [Replace a Supervisor Module, on page 2](#)
- [Replace a Line Card, on page 7](#)
- [Replace a Fan Tray, on page 8](#)
- [Replace Fabric Module, on page 11](#)
- [Replace Power Supply Components, on page 18](#)

Replace Chassis Components



Note The images in this chapter are only for representation purposes, unless specified otherwise. The chassis' actual appearance and size may vary.



Caution Whenever you replace any card, you must always ensure to secure the ejector thumbscrews properly.

Replace Chassis Door Foam Air Filters



Note In general, we recommend that you inspect the air filter every 3 months and replace.

The front doors come with pre-installed air filters (N9K-9804-DF-KIT). If air filters need a replacement, follow this procedure.

Step 1 Remove the two quarter turn fasteners from the front door as shown.

Figure 1: Replace Air Filter

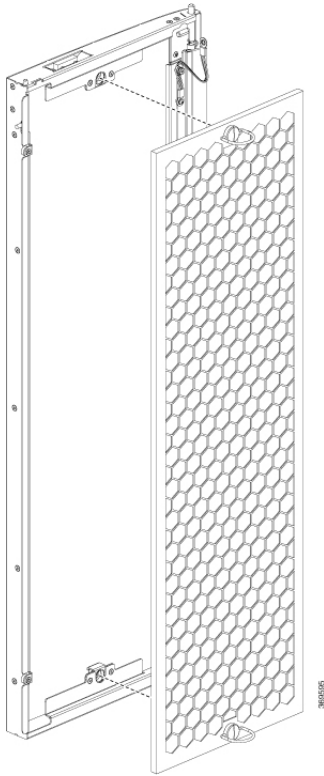

- Step 2** Install the new door filters on both the front doors.
- Step 3** Tighten the two quarter turn fasteners back on the doors.

Replace a Supervisor Module

The switch supports up to two redundant Supervisor Modules (N9K-C9800-SUP-A). When two Supervisor Modules are installed in the switch, one acts as an active module and the other as the standby module. When the active Supervisor Module is removed, the switch automatically makes the standby Supervisor module active. If the switch has only one Supervisor Module that is installed, a new Supervisor can be installed in the empty Supervisor slot during operation.



Note Single Sup is supported for this switch.



Warning Blank faceplates and cover panels serve three important functions: they reduce the risk of electric shock and fire, they contain electromagnetic interference (EMI) that might disrupt other equipment, and they direct the flow of cooling air through the chassis. Do not operate the system unless all cards, faceplates, front covers, and rear covers are in place.

Illustrations are for representational purposes only.

The below figure describes the components used in the Supervisor installation procedure.

Figure 2: Supervisor Module Components

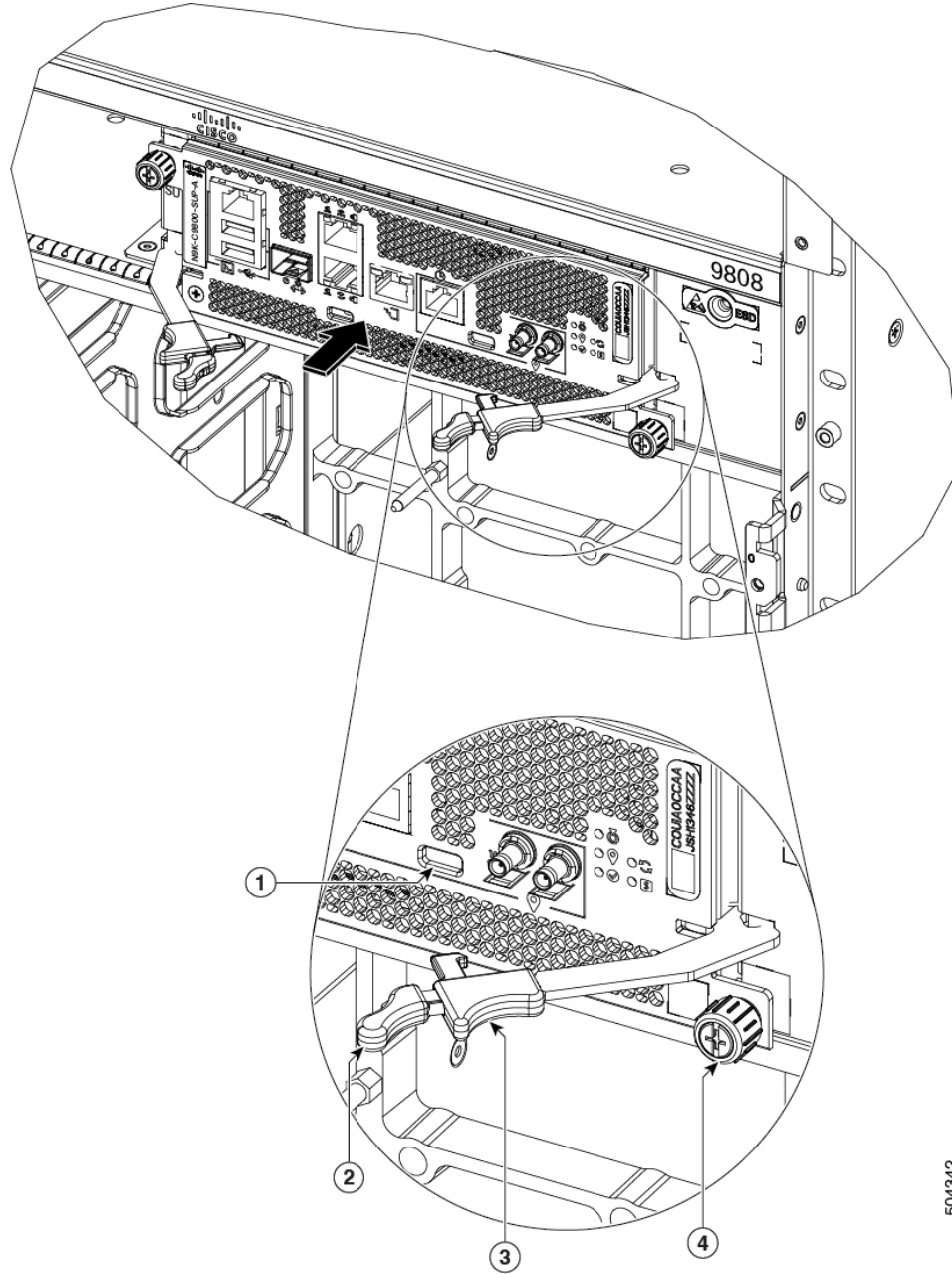

504342

1	Latch Lock	3	Latching Mechanism
2	Ejector Lever Handle	4	Captive Screw



Caution Unlatching the right ejector lever, so that it disengages from the latch lock (Callout 1 in above figure) triggers graceful shutdown of the Supervisor if the module is up. If the module shuts down then wait for the Supervisor status LED to turn off before proceeding.

Moving the latch to the side does not disengage the latch from the lock. This is a safeguard mechanism if an operator initiated shutdown of the supervisor has not been performed before opening the levers. The ejector open will be logged.

- Step 1** Open the packaging for the new Supervisor Module, inspect the module for damage, and verify that the module is the same type as the other Supervisor Module installed in the chassis.
- If the module is damaged, alert the Technical Assistance Center (TAC).
- Step 2** If you are installing the module in an empty slot, remove the blank that is already in that slot by unscrewing its captive screw and pulling it out of the slot. Go to Step 4.
- Step 3** If you are replacing a module that is currently in the chassis, remove the existing module from the chassis by following these steps:
- Run the **poweroff module (x)location** command, in EXEC mode, which gracefully shuts down Supervisor module to prevent any of the file systems from being corrupted.
 - Verify that the Supervisor Status LED for the slot that you specified turns to Amber. Also, you can use the **show module** command to verify that the status of the module is SHUT DOWN.
 - Disconnect the cables from the module.
 - If there are any external drives attached to the module through its USB ports, detach those drives.
 - Loosen the two captive screws (one on each side of the RP) until the screws are no longer in contact with the chassis.
 - Slide the latch on each of the ejector lever outwards from the lever center (see Callout 1 in the below figure).

This action disengages the ejector levers from the faceplate.

Figure 3: Remove Supervisor Module from Chassis

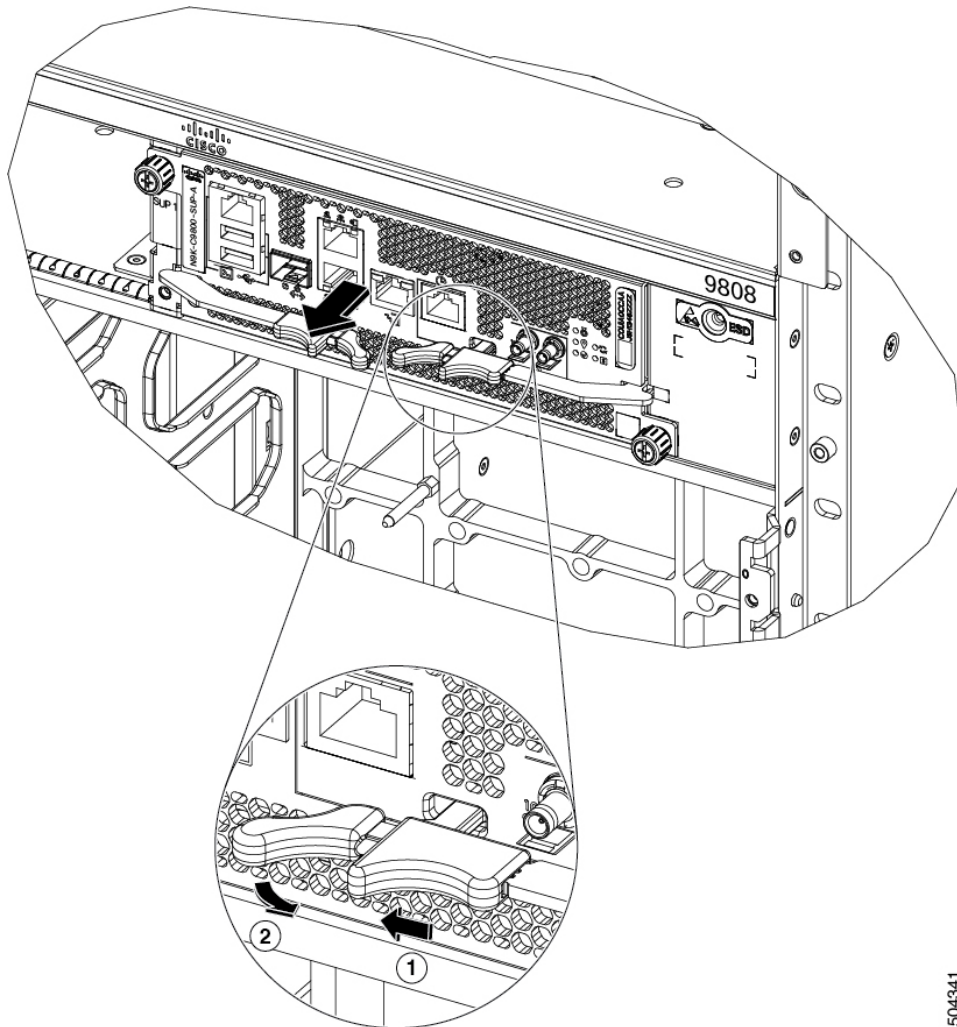

504341

- g) Pull to rotate the levers away from the front of the module (see Callout 2 in the above figure)
The module unseats its connectors from the midplane and moves slightly out of the chassis.
- h) Use one hand to hold the front of the module, place your other hand under the module to support its weight, pull the module out of the chassis, and set it on an antistatic surface or inside an antistatic bag.

Note While performing OIR of the module, wait for 30 seconds before inserting the same or new module in the same slot. This will allow the module to boot properly and reach operational state.

Step 4

To install a new module, follow these steps:

- a) If any of the ejector levers are in closed position slide the latch on the ejector lever outwards from the lever center and pull to rotate the lever away from the front of the module.
This action opens the lever so that the module can be fully inserted into the slot.
- b) Hold the front of the module with one hand and place your other hand under the module to support its weight.
- c) Align the back of the module to the guides in the open Supervisor slot and slide the module all the way into the slot.

The module stops when its front is about 0.25 inches (0.6 cm) outside the front of the chassis.

- d) Rotate the levers firmly all the way to the front of the chassis. Then firmly push the tip of the levers towards the faceplate till the latch hook locks in place behind the faceplate. You may hear a click or see the latch engage. (See Callout 1 in the below figure.)

Make sure that the other end of both levers engages behind the latching slot on the faceplate so that the module fully seats onto the connectors on the midplane.

Note To confirm that the module is installed properly, pull the black tip of each ejector lever lightly, and make sure the lever does not pop out.

Figure 4: Install Supervisor module into Chassis

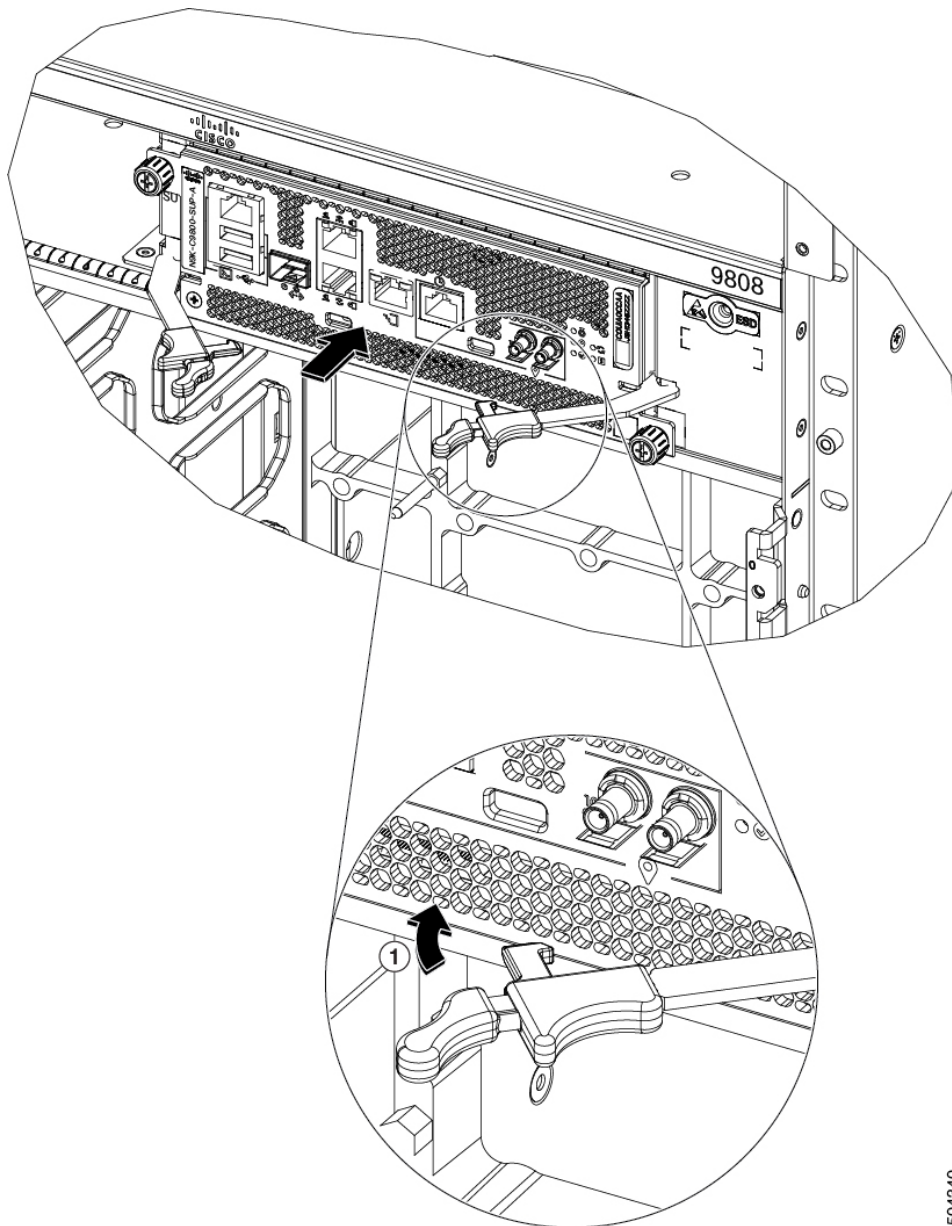

504340

- e) Screw in the two captive screws to secure the module to the chassis. Tighten the screws to 8 in-lb (0.9 N·m) of torque.
 - f) Attach the cables to the module.
 - g) Verify that the Supervisor module status LEDs turn on and appear green.
-

Replace a Line Card

The switch can operate with one or more line cards that are installed in the chassis. If there is at least one line card that is installed and operating in the chassis, you can replace another line card or install a new line card in an empty line card slot.

The Cisco Nexus 9800 series switches support OIR of line cards.



Warning Blank faceplates and cover panels serve three important functions: they reduce the risk of electric shock and fire, they contain electromagnetic interference (EMI) that might disrupt other equipment, and they direct the flow of cooling air through the chassis. Do not operate the system unless all cards, faceplates, front covers, and rear covers are in place.



Warning Invisible laser radiation may be emitted from disconnected fibers or connectors. Do not stare into beams or view directly with optical instruments.

Step 1 Open the packaging for the new line card and inspect the module for damage.

If the module is damaged, contact the Technical Assistance Center (TAC).

Step 2 If you are replacing a module that is currently in the chassis, remove the existing module from the chassis by following these steps:

- a) Run the **poweroff module (x) location** command, which gracefully shuts down the line card.
- b) Verify that the Line Card LED for the slot that you specified turns off. Also, you can use the **show module** command to verify that the status of the card is SHUT DOWN.
- c) Disconnect and label each of the interface cables from the module.
- d) Loosen the two captive screws.
- e) Press the ejector buttons and use the levers to pull the module a couple of inches (about 5 cm) from the chassis. Rotate each of the two ejector levers away from the center of the chassis. The levers unlock themselves from the brackets on the side of the chassis.
- f) Close the ejector levers.
- g) Use one hand to hold the front of the module, place your other hand under the module to support its weight, pull it out of the chassis, and set it on an antistatic surface or inside an antistatic bag.

Step 3 To install the new module, follow these steps:

- a) Hold the front of the module with one hand and place your other hand under the module to support its weight.
- b) Align the back of the module to the guides in the open line card slot and slide the module all the way into the slot (see the following figure).

The module stops when its front is about 0.25 inches (0.6 cm) outside the front of the chassis. Press the ejector buttons and the two levers move part way to the front of the chassis.

Figure 5: Insert a Line Card into the Chassis

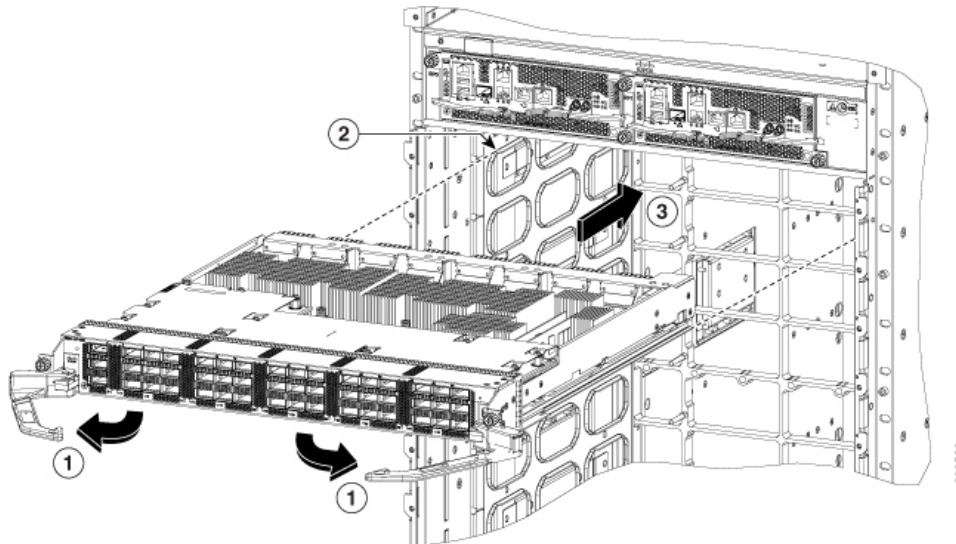

1	Rotate the ejector handle on each end of the module away from the center of the chassis.	3	Slide the module all the way into the slot.
2	Align the bottom of the back of the module with tracks on either side of the slot.		

- c) Rotate the ends of the two levers toward the center of the chassis.

When the levers point straight out from the chassis, their other ends should be locked onto the brackets on the side of the chassis.

As you rotate the levers, the front of the module moves all the way to the front of the chassis and the module fully seats on the chassis.

- d) Tighten the two captive screws to 8 in-lb (0.9 Nm) torque.
 e) Attach each interface cable to the appropriate port on the line card. Use the label on each cable to determine which port each cable attaches to.
 f) Verify that the line card LEDs turn on and appear green.

Replace a Fan Tray

You can remove a fan tray, to either replace it with another fan tray, or to replace a fabric card located behind it.

The switch uses four fan trays but it can operate with three fan trays while you replace one or remove one, to replace one of the fabric cards behind the fan tray. When you remove one fan tray, the other fan trays speed up their fans to maintain the designed airflow.



Note If you cannot replace a fan tray within three minutes, we recommend that you leave it in the chassis until you are ready to replace it.



Note Never remove two fan trays at a time during operation, the switch allows up to two minutes of operations before shutting down unless you replace the missing fan tray within that time. If the switch senses an over temperature condition when multiple fan trays are removed, the shutdown can occur in less than two minutes.

To replace a fan tray, you must perform the following functions:

1. Remove the fan tray.
2. Install a fan tray.

Remove Fan Tray

Remove only one fan tray at a time during switch operations. If you remove more than one fan tray at a time, the switch shuts down within two minutes unless you replace the extra fan trays that you removed within that time.

-
- Step 1** Unscrew the four captive screws on the front of the fan tray until each screw is free of the chassis.
- Step 2** Hold both handles on the front of the fan tray with both of your hands and pull the fan tray out of the slot.
- Step 3** Set the fan tray on antistatic material or inside an antistatic bag.
-

Install Fan Tray

Before you begin

- Fan tray slot is open in the chassis.
- If you are replacing a fabric card behind the open fan tray slot, ensure that the fabric card replacement operation is completed.

-
- Step 1** Use both of your hands to hold the two handles on the front of the fan tray that you are installing.

Figure 6: Remove Fan Tray from the Chassis

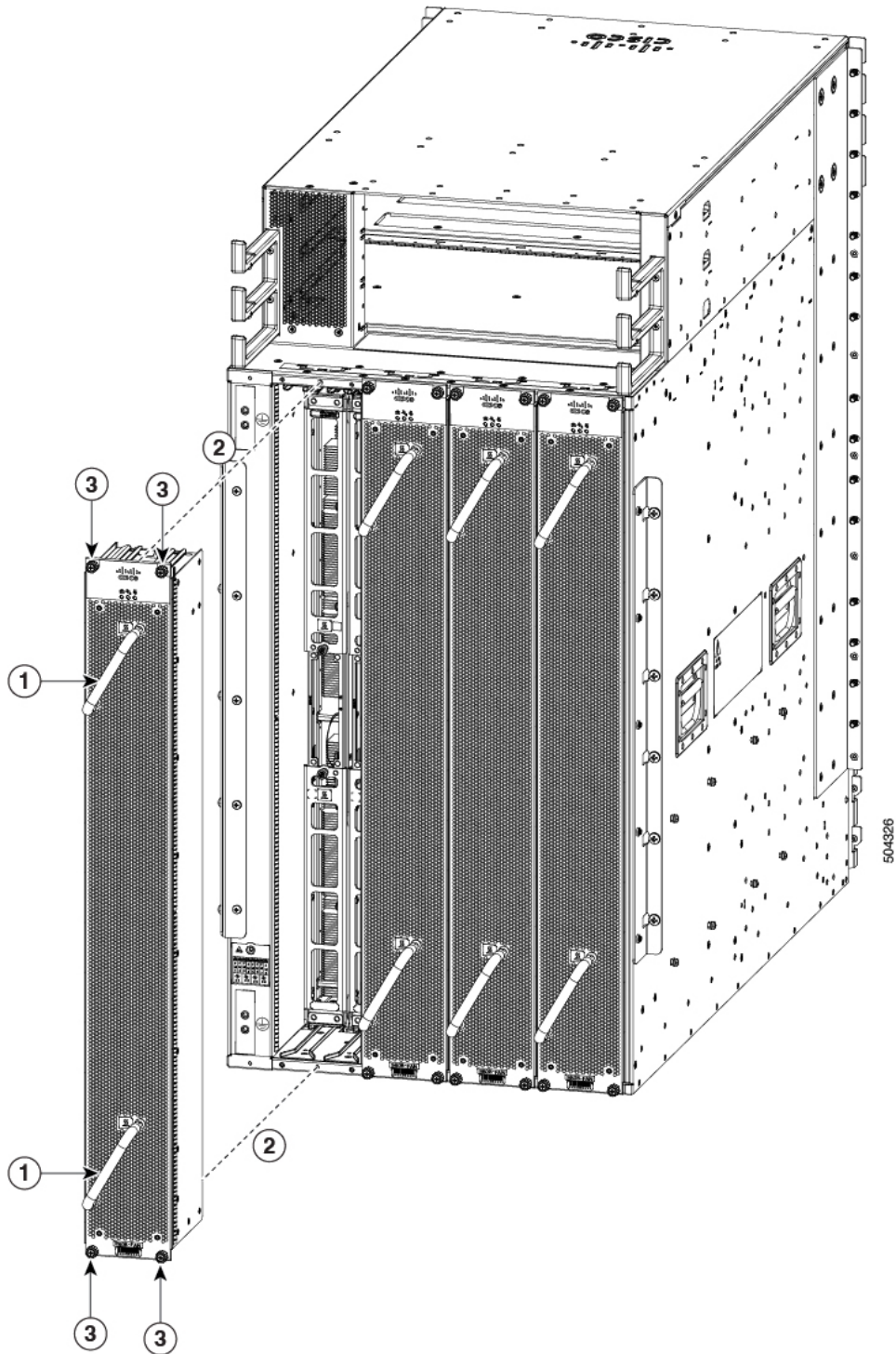

1	Handle	3	Captive screws
2	Align fan tray in position		

- Step 2** Position the fan tray with its rear (the side with the electrical connectors) at the opening for the fan tray slot in the chassis.
- Step 3** Align the two tracks on the top of the fan tray with the two sets of rails at the top of the open fan tray slot in the chassis.
- Step 4** Slide the fan tray all the way into the slot until the front of the fan tray touches the chassis.
- Make sure that the four captive screws on the front of the fan tray align with the four screw holes in the chassis.
- Step 5** Screw in the four captive screws to secure the fan tray to the chassis. Tighten the screws to 8 in-lb (0.9 N·m) of torque.
- Step 6** Verify that the fan tray STATUS LED turns on and becomes green, approximately within 20 seconds.
-

Replace Fabric Module

The switch supports replacement of a fabric module while others are operating. To replace a fabric module, you must do each of the following:

- Shut down the fabric module being replaced.
- Remove the fan tray covering the fabric module in the chassis.
- Remove the fabric module.
- Install the new fabric module.



Note We recommend that you insert the fabric modules in the sequence starting with FM1, FM2, and so on (from left to right). Use the adjacent module as a guide to retain the modules in vertical position.

- Reinstall the fan tray over the fabric module.
- Activate the fabric module.

The Cisco 9800 series switches support OIR of fabric module.

To maintain the designed airflow while you remove the fan tray, the fans in the other fan trays increase their speed. During operations, it is required that you remove only one fan tray at a time and reinstall that fan tray within three minutes to avoid the possibility of having the switch overheat and shut down. If you remove more than one fan tray at a time, the switch shuts down if you do not reinstall the extra missing fan trays within two minutes (the shutdown can occur earlier if the switch over heats).

Remove a Fabric Module

Before you begin

- You must wear an electrostatic discharge (ESD) wrist strap or other ESD protective device while handling modules.
- Prepare an antistatic surface or packing materials for each module that you remove from the chassis.

-
- Step 1** If you are replacing a fabric module, open the packaging for the new module and inspect it for damage. If the module is damaged, alert the Technical Assistance Center (TAC) and stop this replacement process until you have an undamaged module to install.
- Step 2** Run the **no poweroff module (x)location** command.
- Verify that the fabric LED for the slot that you specified turns off. Also, you can use the **show module** command to verify that the status of the module is SHUT DOWN.
- Step 3** Remove the fan tray covering the fabric module in the chassis.
- Refer the fan tray removal procedure: [Replace a Fan Tray, on page 8](#)
- Step 4** Remove the fabric module that you are replacing by following these steps:
- Unscrew the two captive screws on the center of each of the two handles on the fabric module (see Callout 1 in the following figure).
 - Rotate the handles outwards until they stop (see Callout 2 in the following figure).
 - With each of the two handles in your two hands, pull the module a couple of inches (about 5 cm) out of the slot (see the following figure).

Figure 7: Removing a Fabric Module from the Chassis

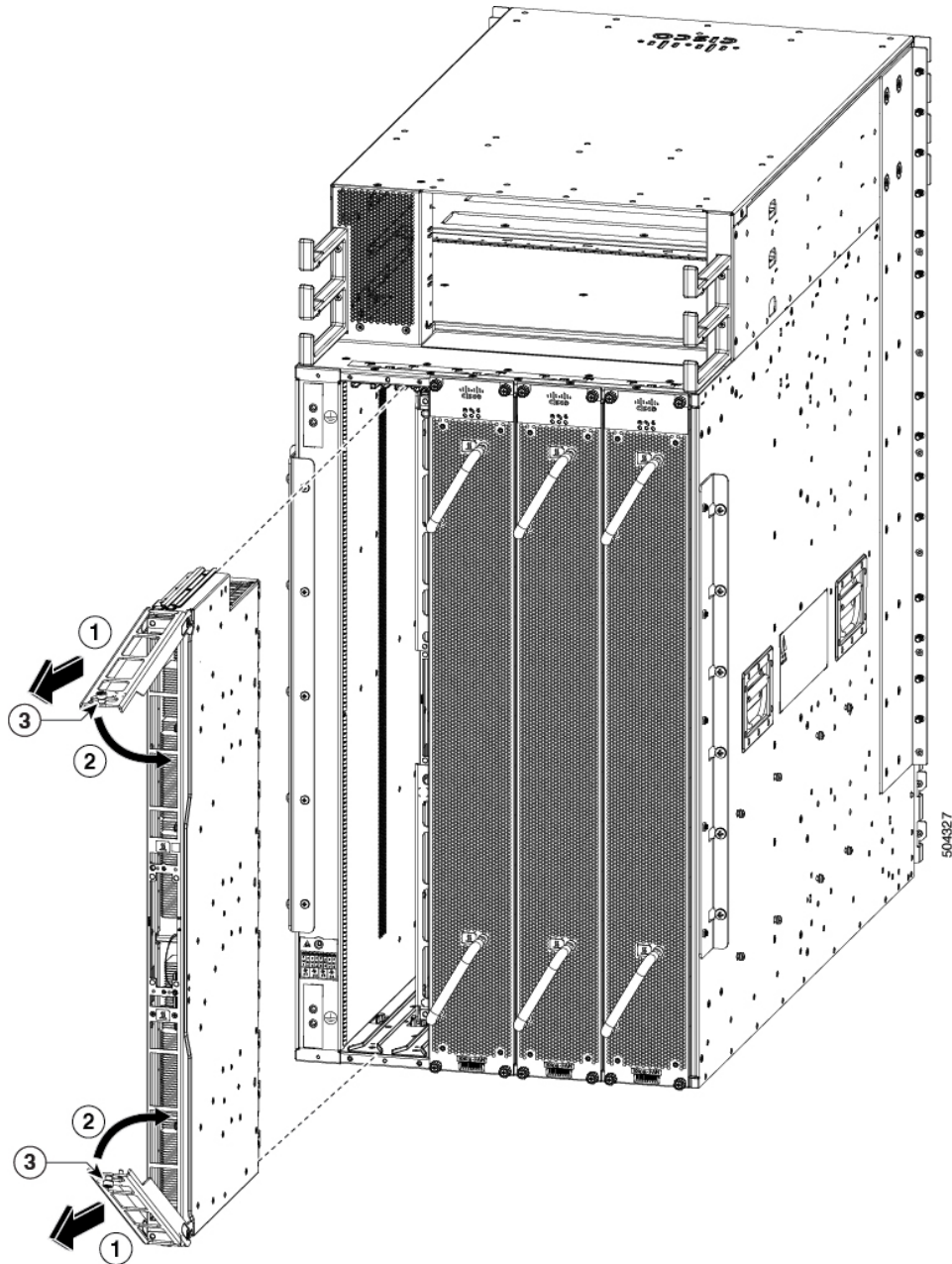

1	Pull on both handles to partially remove the fabric module from the chassis	3	Two captive screws (one on each handle)
2	Rotate both ejector handles to the front of the module		

- d) Place one hand under the Fabric Module to support its weight, place your other hand on the front of the module, and slide the module out of the slot.

- e) Rotate both handles back to the front of the module until they are in place. Fasten each handle to the module using the captive screw on the back of the handle. Tighten the screw to 8 in-lb (0.9 N·m) of torque.
 - f) Rotate the module 90 degrees and lay it flat on an antistatic surface or in an antistatic bag.
-

Install a Fabric Module

Step 1 Unscrew the two captive screws (one on each ejector handle) and rotate the ejector handles at least 30 degrees. Ensure that the locking posts on the top and bottom of the chassis rotate into the module so that the module can slide fully into the slot.

Step 2 Place one hand on the front of the module and turn the module 90 degrees so that the electrical connectors are on the bottom.

Step 3 Align the guide bar on the bottom of the fabric module into the guide slot at the bottom of the fabric module slot, and make sure that the guide rails on the top of the fabric module align with the track on the top of the slot.

Note The lower guide rail extends to the back of the chassis. The upper guide rail does not connect until the module is halfway into the chassis.

Figure 8: Install Fabric Module

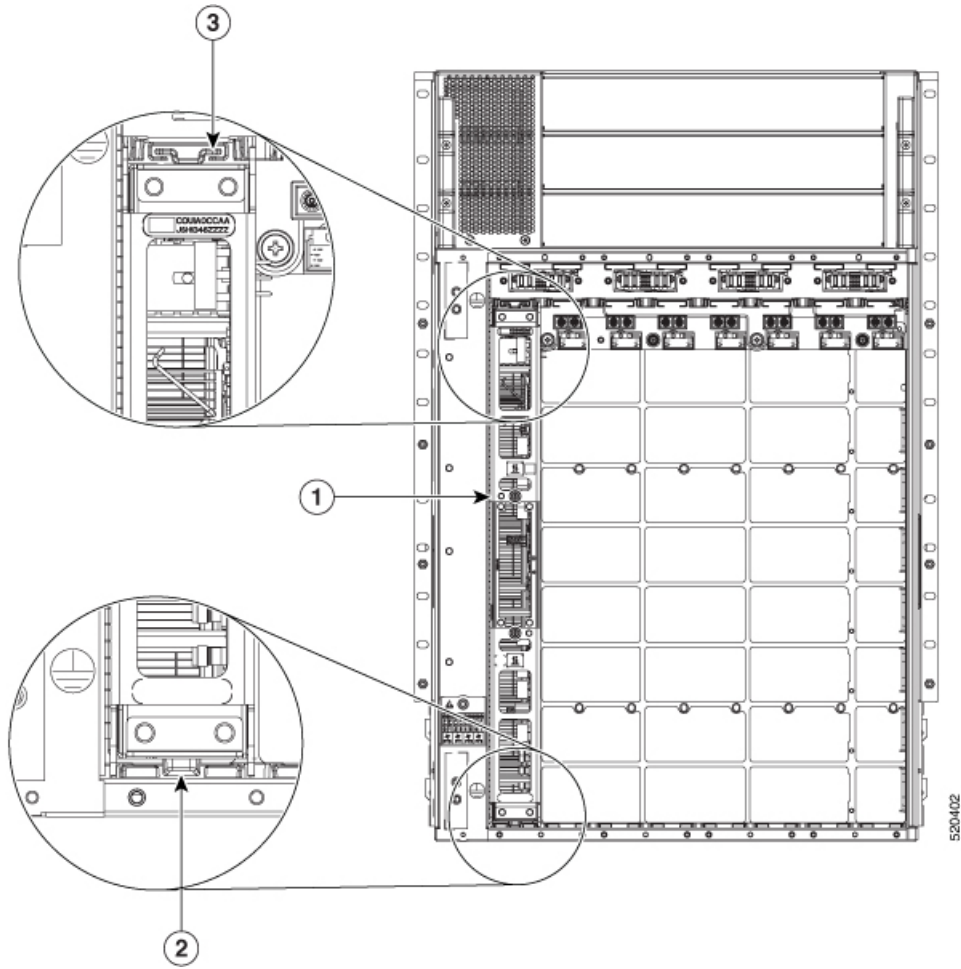

1	Always install the fabric module in a vertical position
2	Guide bar and guide slot
3	Guide rail and track

Figure 9: Installing a Fabric Module

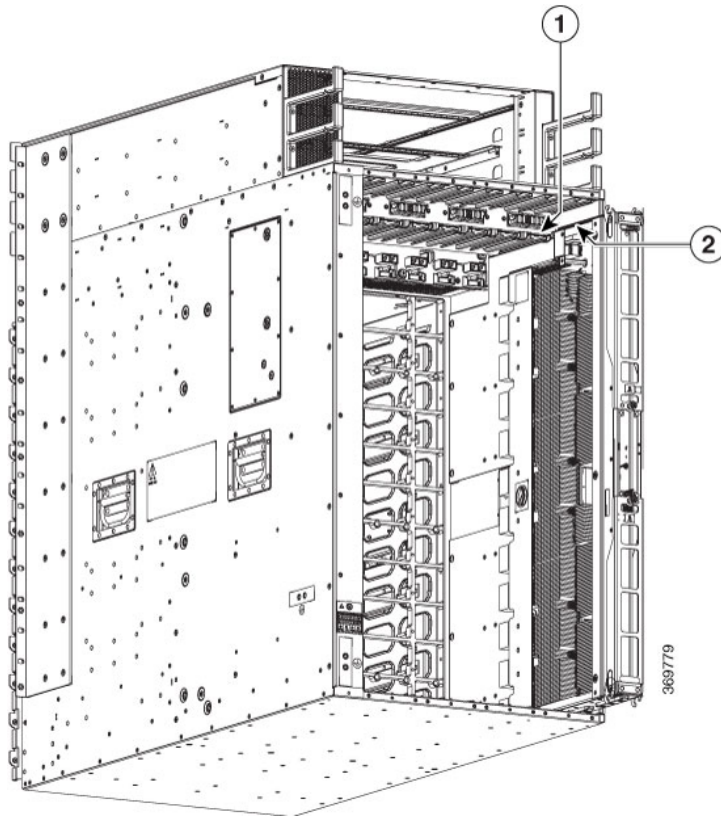

1	Chassis top fabric module guide rail.	2	Insert fabric module top guide rail into chassis top fabric module guide rail.
---	---------------------------------------	---	--

Figure 10: Fabric Module installed in a Chassis

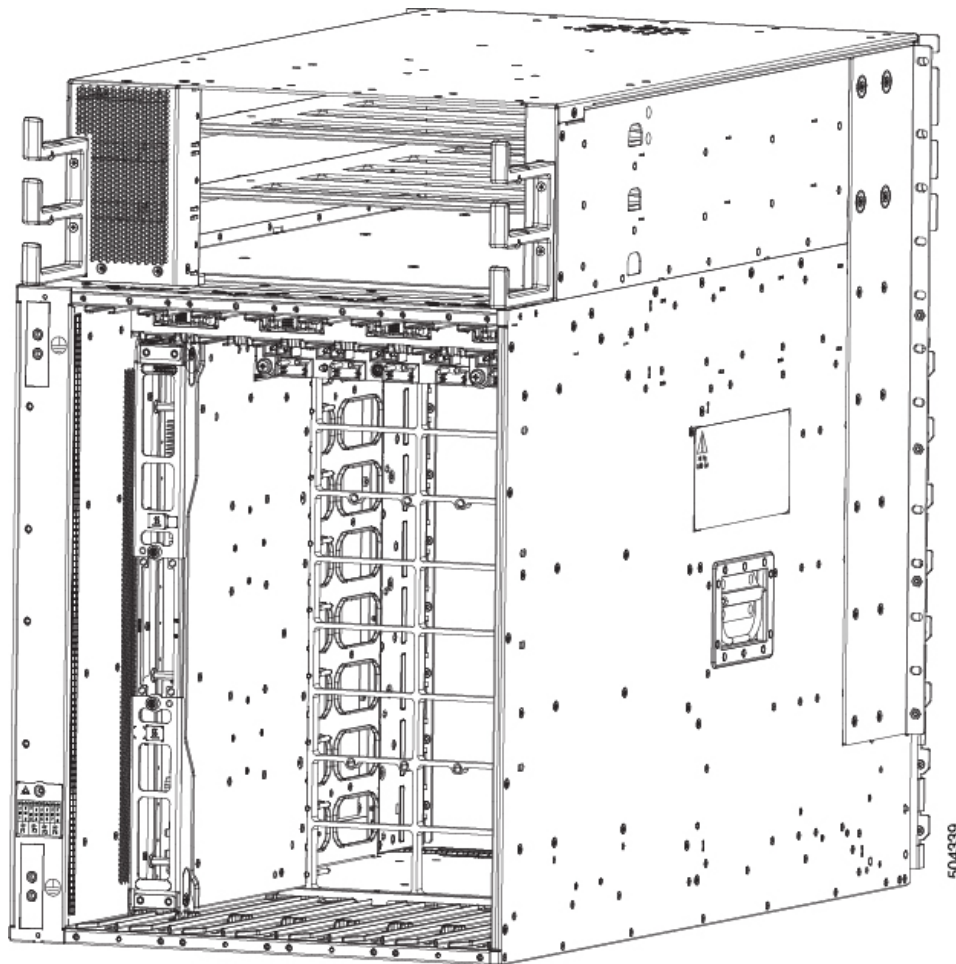

- Step 4** Slide the module all the way into the slot.
- Step 5** Rotate both ejector levers to 90 degrees to the front of the chassis and be sure that the module is locked to the top and bottom of the slot.
- Step 6** Tighten the captive screw on each of the two levers to 8 in-lb (0.9 N-m) of torque, so that each lever is locked in place on the module.
- Step 7** Verify the fabric module LEDs become green.
- Step 8** Reinstall the fan tray over the fabric module.
Refer the installing the fan tray procedure: [Install Fan Tray, on page 9](#)
- Step 9** Run the **reload module location** command.
- Step 10** Wait for the fabric module to become operational. Use the **show module** command to verify the status.
- Note** The fabric module must be operational before resetting the fabric plane.
- Step 11** Verify that the Fabric LED for the slot that you specified turns on. Also, you can verify that the module is in power on state by running the **show module** command to verify the status of the module to be POWERED_ON.

Since the Fan trays are blocking the view, fabric module LEDs might not be visible. Therefore, you can verify the fabric module LEDs status using **show module** command.

Replace Power Supply Components

The Cisco Nexus 9800 series switches support OIR of power modules. If you are replacing a redundant power module, you can replace the power module while the system remains powered on without any electrical hazard or damage to the system. This feature enables you to replace a power module while the system maintains all routing information and ensures session preservation.

However, to maintain operational redundancy and proper cooling, and to meet EMI compliance standards, you must have at least one working redundant power module that is installed. When you remove a failed power module with the switch in operation, perform the replacement as quickly as possible. Make sure you have the replacement power module ready before beginning the removal and installation procedure.



Note For the RP to communicate properly to a power module in a power tray, input power to at least one of the power modules in the power tray should be present.

This section contains procedures on how to replace the power modules.



Caution Do not turn off the switch on the power tray to remove individual power modules. Power modules support OIR, so they can be removed and replaced with the power on and the system operating.

Install Power Shelf Bezel

Follow these steps to install a power shelf bezel on a chassis:

Place the power supply bezel as shown in the below figure and secure it with the provided jackscrews.

Figure 11: Power Supply Bezel

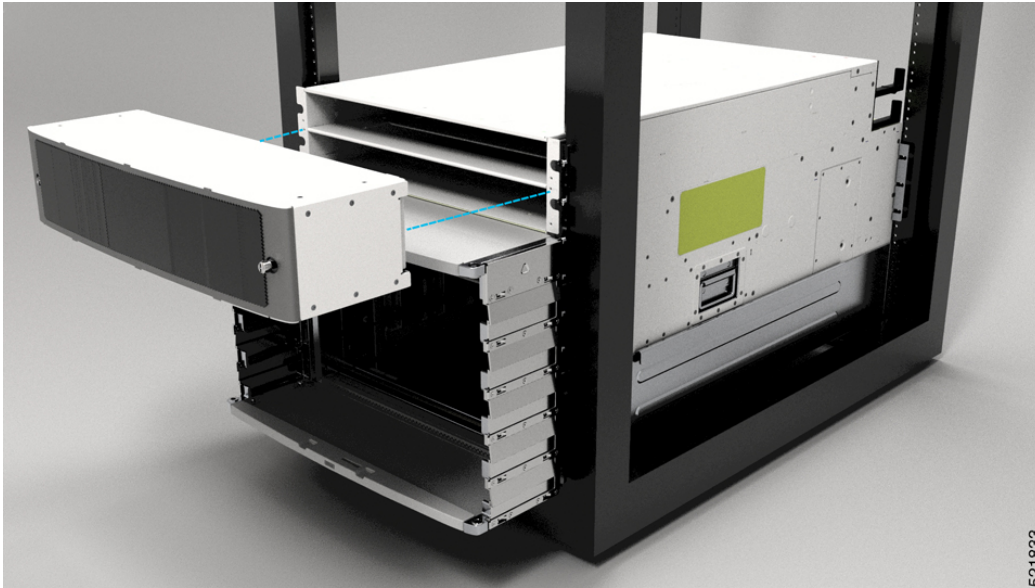

Replace HVAC Power Module

Follow these steps to remove HVAC power modules from the chassis.

-
- Step 1** Do not Power OFF (0) the standby mode switch.

Figure 12: HV Power Tray Standby Mode Switch

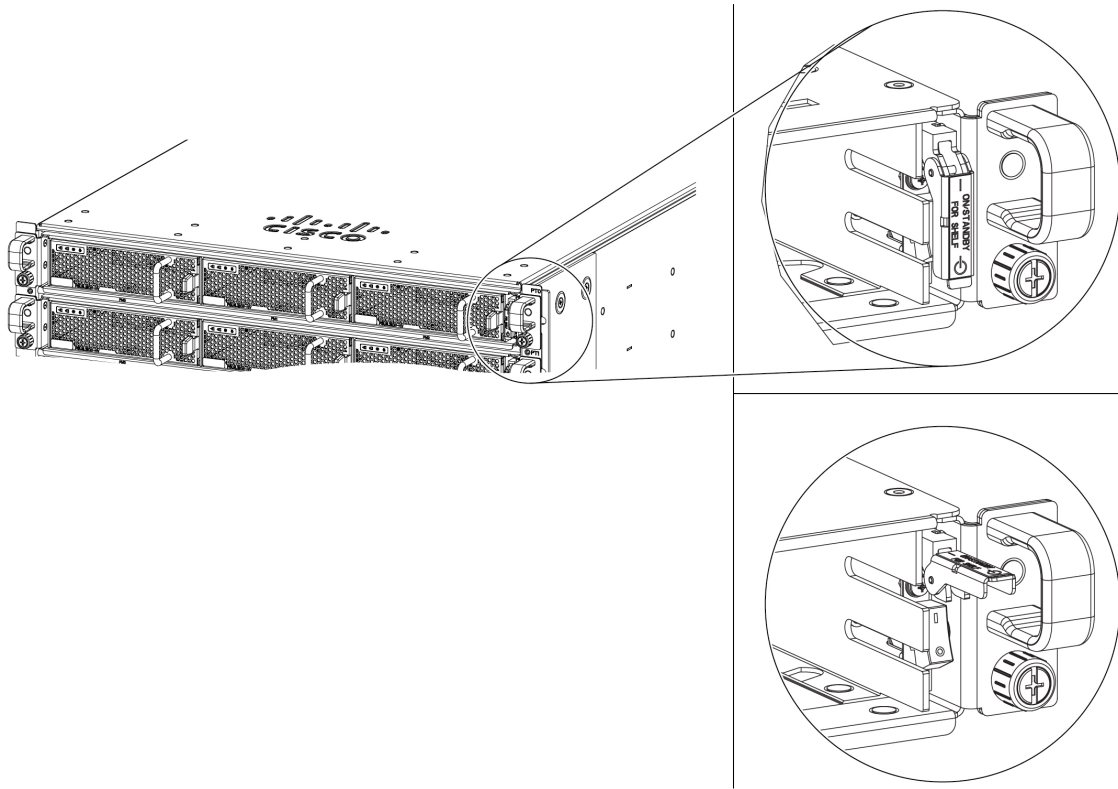

5C5037

Step 2 Slide the power module out of its bay while supporting it with your other hand to remove it.

Figure 13: HV Power Supply

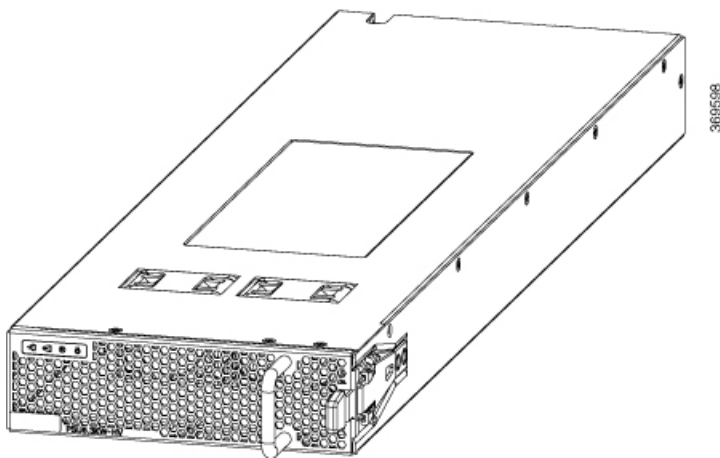

369598

Step 3 Slide the new power module into the bay until it mates with its connector.

Figure 14: HV Power Supply on Tray

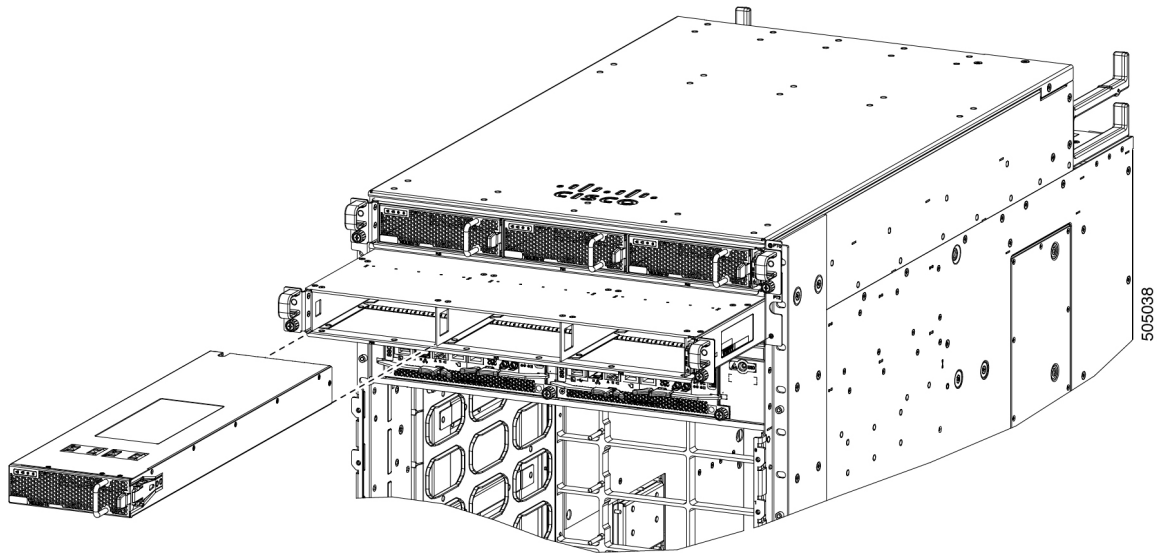
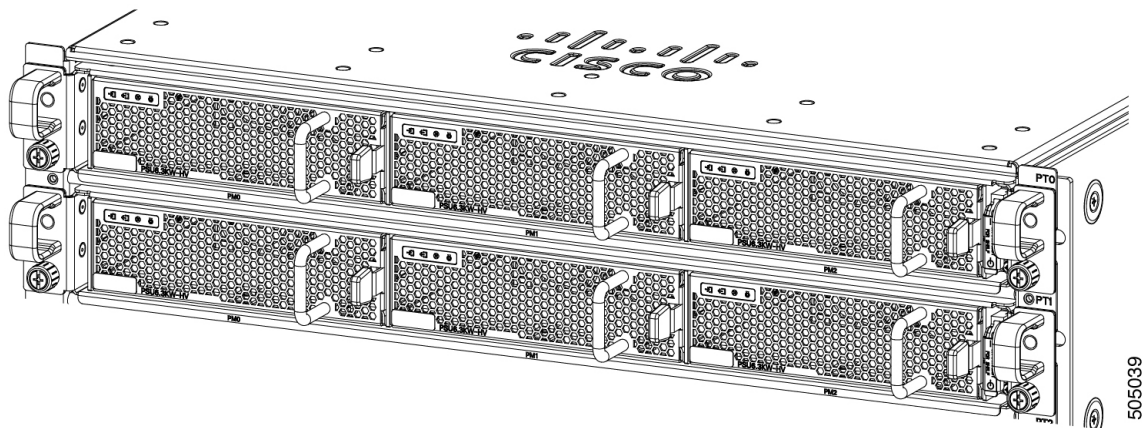
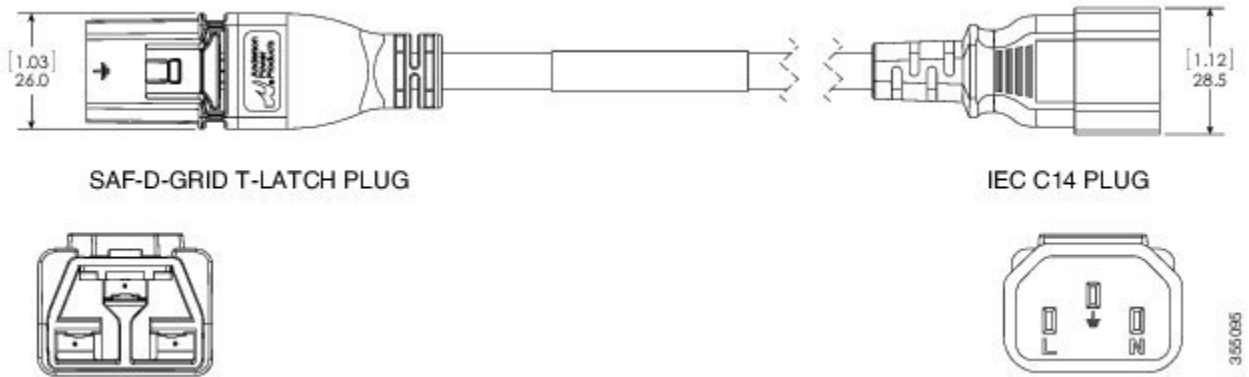

Figure 15: HV Power Supply Trays



Step 4 Verify that the Saf-D-Grid plug is plugged in completely to secure the built-in retaining latch.

Note Saf-D-Grid plug has a retaining latch that must be depressed and gently pulled to release the plug from the receptacle.

Figure 16: SAF-D-Grid Plug

Step 5 Verify that the (green) power indicator on the front of the power module goes on.
