



Unpack and Install the Chassis

- [Unpack and Install the Chassis, on page 1](#)
- [Unpack the Chassis, on page 1](#)
- [Install Bottom-Support Rails, on page 2](#)
- [Transfer Chassis to a Mechanical Lifting Device, on page 3](#)
- [Mount Chassis Into the Rack, on page 5](#)
- [Attach Front Door to Chassis, on page 8](#)

Unpack and Install the Chassis



Note The images in this chapter are only for representation purposes, unless specified otherwise. The chassis' actual appearance and size may vary.

Unpack the Chassis



Tip Be sure to save the packaging in case you need to return any of the components products.

Ensure that there is sufficient room around the chassis pallet for unpacking. For information about the chassis dimensions and clearance requirements see, *Clearance Requirements*.

Carefully move the pallet containing the chassis to the staging area where you plan on unpacking it.

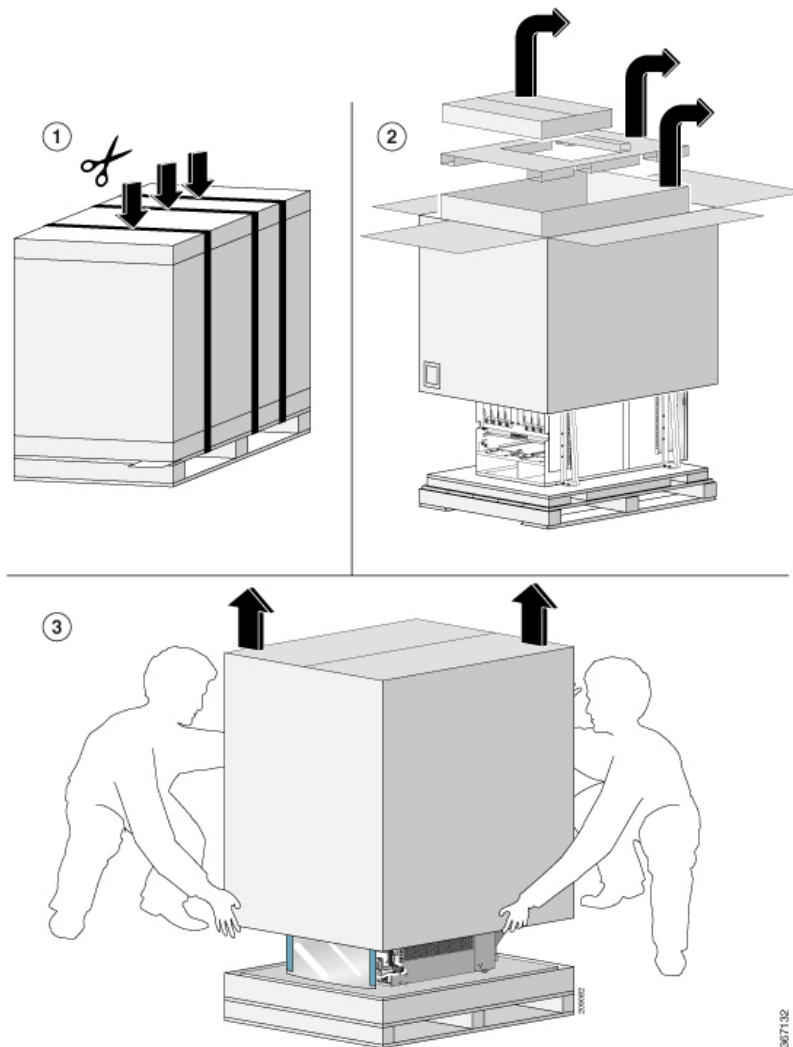

Remove the shipping brackets:

- 16 x M4 screws from the chassis

To make the chassis weigh less for moving, remove the following module and place them where their connectors will not be damaged:

- Fan trays

Leave the chassis on the pallet until you are ready to move and install the chassis in a rack.

Install Bottom-Support Rails

The bottom-support rails support the weight of the chassis in the rack. To maximize the stability of the rack, you must attach these rails at the lowest possible rack unit (RU).

- Step 1** Position the vertical rack rails at 32" depth to match with the length of the bottom-support rails. Check spacing considerations.
- Step 2** Attach the bottom-support rail to the rack using a Phillips torque screwdriver on M6 x 19 mm or 12–24 x 3/4 inch screws for each end of the rail (as shown in the following figure) and tighten each screw to 40 in-lbs (4.5 N-m) of torque.

Figure 1: Attach Bottom-Support Rails to a Rack

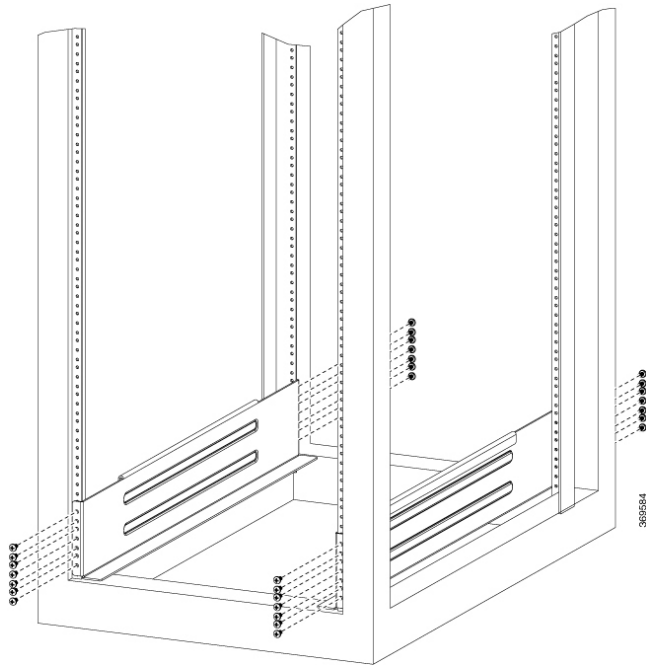

Note Use at least three screws on each end of each bottom-support rail.

- Step 3** Repeat Steps 1 and 2 to attach the other bottom-support rail to the rack.

Note Make sure that the two bottom-support rails are level with one another. If they are not level, adjust the higher rail down to the level of the lower rail.

What to do next

Mount the chassis into the rack.

Transfer Chassis to a Mechanical Lifting Device

- Step 1** Place the mechanical lifting device in front of the chassis on the pallet (or on Line Card side) as shown.

Note Illustrations are for representational purposes only.

Figure 2: Align the Lifting Device in Front of the Chassis on the Pallet



Step 2 Prepare to use the mechanical lifting device by placing a piece of cardboard on the surface of the lift (to prevent scratching).

Step 3 With at least two or three people move the chassis carefully from the pallet onto the lifting device as shown.

Figure 3: Move the Chassis on to the Lifting Device

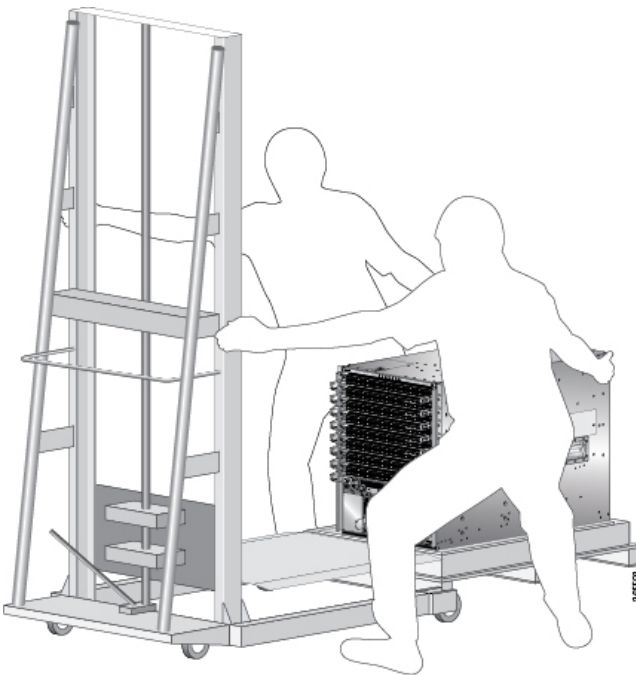

What to do next

After moving the chassis to the room or area where you will install it, begin the procedure to mount the chassis into the rack.

Mount Chassis Into the Rack

To accommodate equipment racks with different mounting hole patterns, the chassis mounting brackets have groups of screw holes on either side. The mounting holes in the chassis mounting brackets are spaced so that one mounting hole in each hole group aligns with a corresponding hole in the equipment rack. By using the corresponding mounting hole (in the same hole group) on the opposite side of the chassis, you can level the chassis in the rack.



Note To lift the chassis, use a mechanical lift. Do not use the handles on the side of the chassis. Use the side handles for only repositioning the chassis after it is already on the mechanical lift or in the rack or cabinet.

Step 1 Using your mechanical lift, raise the chassis so that it is in level with or not more than 1/4 inch [0.635cm] above the rails.

Step 2 Push the chassis all the way onto the rack so that the vertical mounting brackets on the front of the chassis come in contact with the vertical mounting rails on the rack.

Step 3 Use screws provided with the rack to secure the chassis with the vertical mounting rails on the rack.

Note You should remove the power shelf to facilitate attaching chassis to the rack.

Step 4 Use the screws provided with the rack to attach the chassis rear rails.

Figure 4: Attach Chassis to Rack - Rear Left View

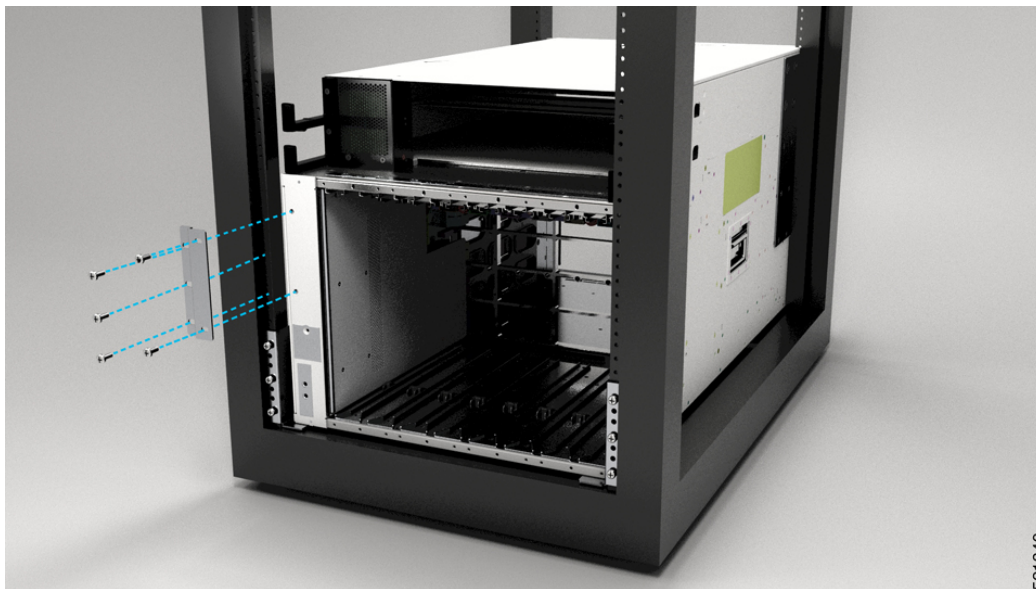
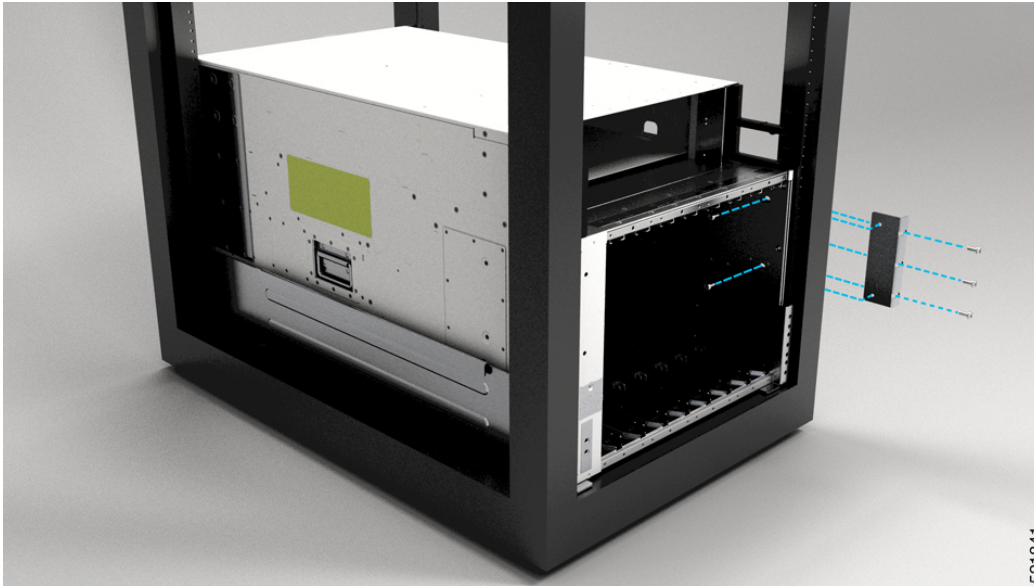

Figure 5: Attach Chassis to Rack - Rear Right View



Note We provide 10-32 screws to secure the left and right bracket. The screws to attach bracket to rack come from rack supplier.

What to do next

Connect the chassis to the ground at your facility.

Ground the Chassis

Step 1 Locate the chassis grounding receptacles on your chassis.

You can locate them at the following position:

- At the left side panel, lower section towards the rear

Figure 6: Chassis Ground Receptacles

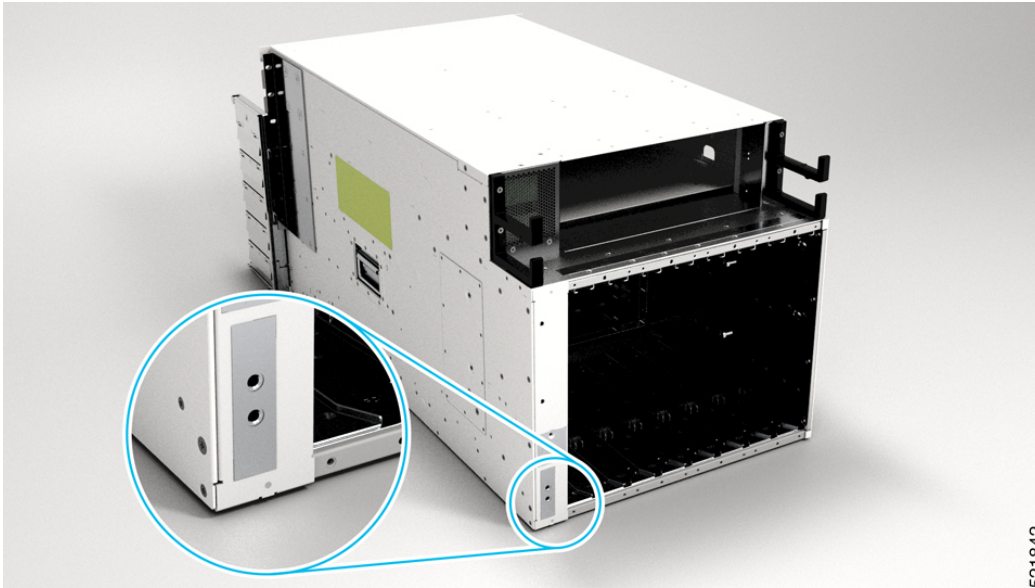

- Step 2** Use the wire stripper to strip one end of the 2-AWG wire approximately 0.75 inches (19.05 mm).
- Step 3** Insert the 2-AWG wire into the wire receptacle on the grounding lug.

Figure 7: Ground the Chassis

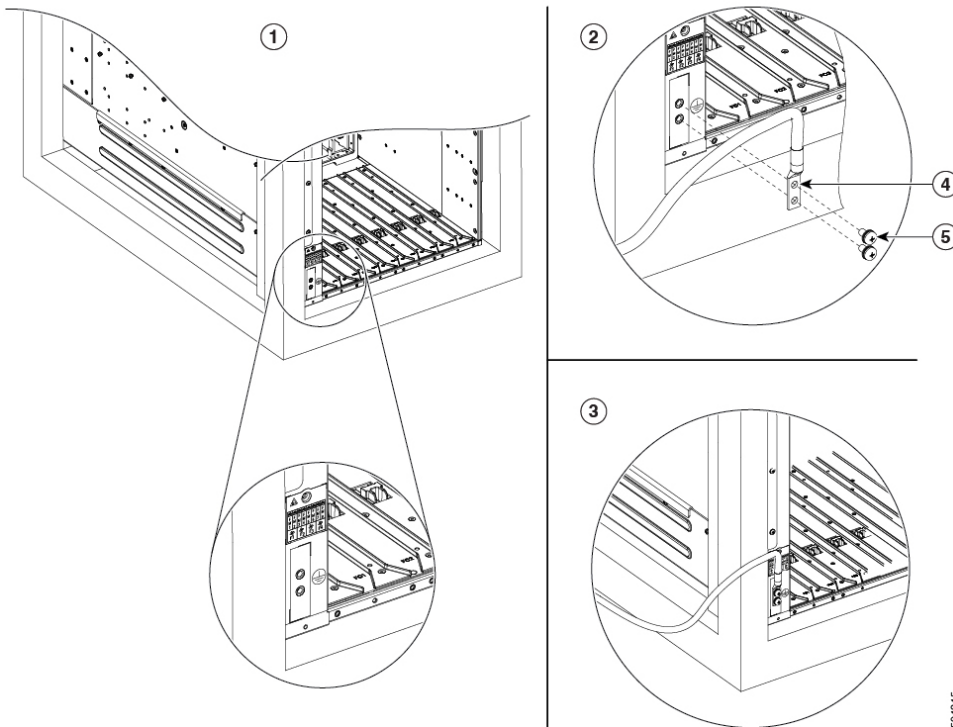

1	Locate ground	4	Align the lug holes
---	---------------	---	---------------------

2	Prepare lug	5	Tighten the screws
3	Ground the chassis		

- Step 4** Use the crimping tool to carefully crimp the wire receptacle around the wire; this step is required to ensure a proper mechanical connection.
- Step 5** Insert the two screws through the holes in the grounding lug. Ensure that the grounding lug does not interfere with other hardware components.
- Step 6** Use the Phillips screwdriver to carefully tighten the screws to 60 in-lbs 6.7 (N-m) of torque until the grounding lug is held firmly to the chassis. Do not overtighten the screws.
- Step 7** Connect the opposite end of the grounding wire to the appropriate grounding point at your site to ensure an adequate chassis ground.

What to do next

Attach the chassis doors.

Attach Front Door to Chassis

Before you begin

Before you can attach the front door to the chassis, you must attach the cable management brackets, bottom plate, and top hood onto the chassis.

Required tools and equipment:

- Phillips screwdriver with a torque capability (customer supplied)

- Step 1** Remove the power shelf bezel from the chassis, if already installed.
This is to ease the installation of chassis doors.
- Step 2** On the back side (open side) of one door, pull in on two protruding spring pins so that the pins are held inside the door frame.

Figure 8: Front Door Pins

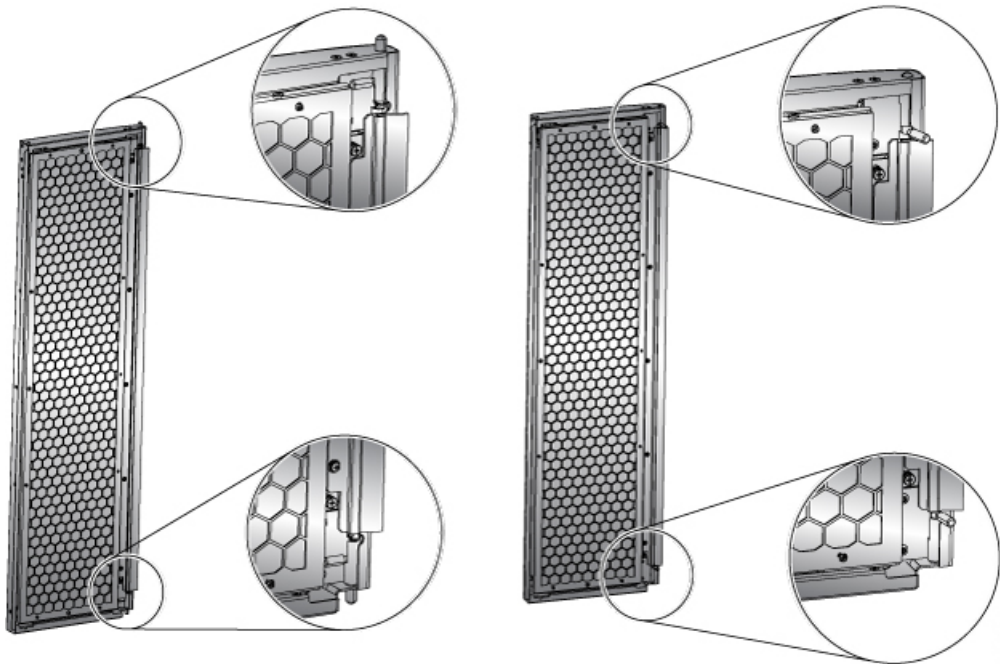

366132

Step 3

Align the spring pin to hole in the bottom plate and release the spring pin, so that they insert into the bottom hole.

Figure 9: Attach Front Door

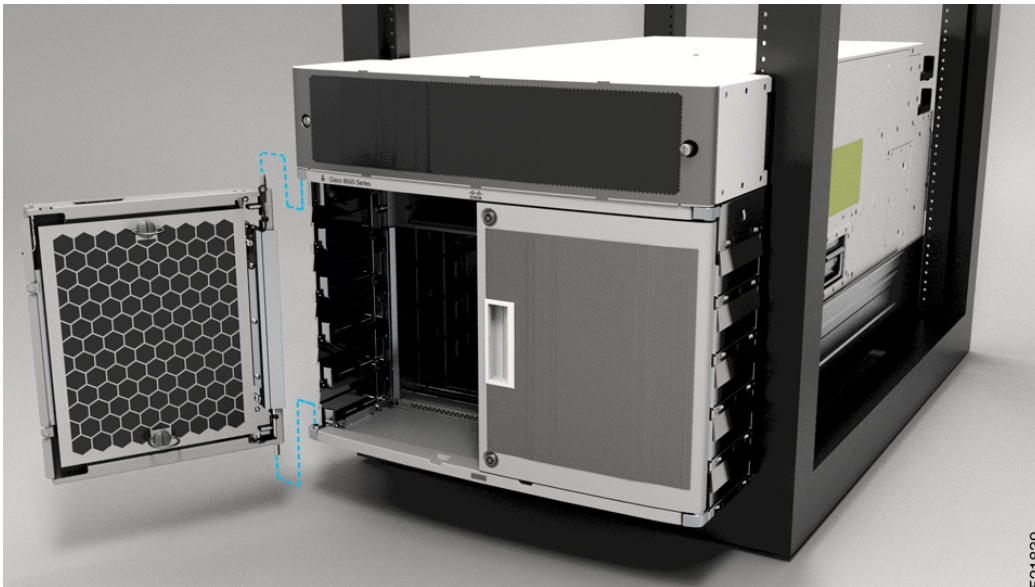

521839

Step 4

Now align the spring pin to hole in the top hood and release the spring pin.

Step 5

Ensure the pins are properly inserted into the holes so that the door can freely swing on the spring pins.

Step 6

Repeat Steps 2–5 to install the other front door.

Step 7

Ground the front door.

For information on grounding the front door, see [Ground the Front Door, on page 10](#).

Step 8 Replace the power supply bezel and secure it with the provided jackscrews.

For information on replacing the power supply bezel, see [Install Power Shelf Bezel](#).

Note Install the following modules, if you had them removed from the chassis while mounting into the rack.

- Fan trays

For more information on replacing components, see [Replace Chassis Components](#).

Ground the Front Door



Note To comply with GR-1089, you have to bond the front doors to the ground port on the chassis using the ground braid.

Step 1 Install the grounding cable towards the side of the front door.

Step 2 Apply the star ring terminal end of the grounding cable to the front door. Tighten the screw to 11.5 to 15 in-lb (1.3 to 1.7 N-m) of torque to provide proper bonding.

Figure 10: Ground Cable to Chassis

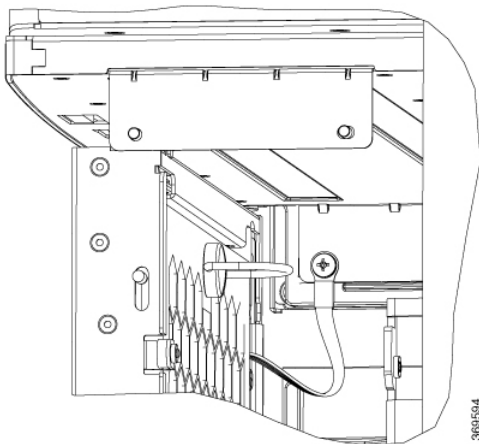

Note Fasten the ground straps on both the doors to the chassis.

Step 3 Connect the other round terminal of the grounding cable to the ground port on the cable management bracket on either left or right side of the chassis. Use the front hole of the bracket that connects the top cover to the cable management bracket. Tighten the M4 screw to 11.5 to 15 in-lb (1.3 to 1.7 N-m) of torque.

Step 4 Repeat Steps 1–3 to install the grounding cable to the other front door.

Step 5 Close and lock the front door.

What to do next

Continue to power on the switch.

