



Installing the Chassis

- [Safety, on page 1](#)
- [Network Equipment-Building System \(NEBS\) Statements, on page 4](#)
- [Preparing to Install the Chassis, on page 7](#)
- [Unpacking and Inspecting the Chassis, on page 8](#)
- [Installing the Chassis in a Four-Post Rack, on page 9](#)
- [Grounding the Chassis, on page 14](#)
- [Starting the Switch, on page 16](#)

Safety

Before you install, operate, or service the switch, see the *Regulatory, Compliance, and Safety Information for the Cisco Nexus 3000 and 9000 Series* for important Safety Information.



Warning **Statement 1071**—Warning Definition

IMPORTANT SAFETY INSTRUCTIONS

Before you work on any equipment, be aware of the hazards involved with electrical circuitry and be familiar with standard practices for preventing accidents. Read the installation instructions before using, installing, or connecting the system to the power source. Use the statement number provided at the end of each warning statement to locate its translation in the translated safety warnings for this device.

SAVE THESE INSTRUCTIONS



Warning **Statement 1089**—Instructed and Skilled Person Definitions

An instructed person is someone who has been instructed and trained by a skilled person and takes the necessary precautions when working with equipment.

A skilled person or qualified personnel is someone who has training or experience in the equipment technology and understands potential hazards when working with equipment.

There are no serviceable parts inside. To avoid risk of electric shock, do not open.

**Warning Statement 1074**—Comply with Local and National Electrical Codes

To reduce risk of electric shock or fire, installation of the equipment must comply with local and national electrical codes.

**Note Statement 407**—Japanese Safety Instruction

You are strongly advised to read the safety instruction before using the product.

<https://www.cisco.com/web/JP/techdoc/pldoc/pldoc.html>

When installing the product, use the provided or designated connection cables/power cables/AC adapters.

〈製品仕様における安全上の注意〉
www.cisco.com/web/JP/techdoc/index.html

接続ケーブル、電源コードセット、ACアダプタ、バッテリーなどの部品は、必ず添付品または指定品をご使用ください。添付品・指定品以外をご使用になると故障や動作不良、火災の原因となります。また、電源コードセットは弊社が指定する製品以外の電気機器には使用できないためご注意ください。

**Warning Statement 1017**—Restricted Area

This unit is intended for installation in restricted access areas. Only skilled, instructed, or qualified personnel can access a restricted access area.

**Warning Statement 1030**—Equipment Installation

Only trained and qualified personnel should be allowed to install, replace, or service this equipment.

**Warning Statement 1091**—Installation by an Instructed Person

Only an instructed person or skilled person should be allowed to install, replace, or service this equipment. See statement 1089 for the definition of an instructed or skilled person.

There are no serviceable parts inside. To avoid risk of electric shock, do not open.

**Warning Statement 1005**—Circuit Breaker

This product relies on the building's installation for short-circuit (overcurrent) protection. To reduce risk of electric shock or fire, ensure that the protective device is rated not greater than: 20A for AC, 60A for DC



Warning Statement 1028—More Than One Power Supply

This unit might have more than one power supply connection. To reduce risk of electric shock, remove all connections to de-energize the unit.



Warning Statement 1003—Power Disconnection

To reduce risk of electric shock or personal injury, disconnect power before removing or replacing components or performing upgrades.



Warning Statement 1046—Installing or Replacing the Unit

To reduce risk of electric shock, when installing or replacing the unit, the ground connection must always be made first and disconnected last.

If your unit has modules, secure them with the provided screws.



Warning Statement 1022—Disconnect Device

To reduce the risk of electric shock and fire, a readily accessible disconnect device must be incorporated in the fixed wiring.



Warning Statement 1033—Safety Extra-Low Voltage (SELV)—IEC 60950/ES1—IEC 62368 DC Power Supply

To reduce the risk of electric shock, connect the unit to a DC power source that complies with the SELV requirements in IEC 60950-based safety standards or ES1 and PS1 requirements in IEC 62368-based safety standards or to a Class 2 power supply.



Warning Statement 1024—Ground Conductor

This equipment must be grounded. To reduce the risk of electric shock, never defeat the ground conductor or operate the equipment in the absence of a suitably installed ground conductor. Contact the appropriate electrical inspection authority or an electrician if you are uncertain that suitable grounding is available.

**Warning Statement 1032**—Lifting the Chassis

To prevent personal injury or damage to the chassis, never attempt to lift or tilt the chassis using the handles on modules, such as power supplies, fans, or cards. These types of handles are not designed to support the weight of the unit.

**Warning Statement 1006**—Chassis Warning for Rack-Mounting and Servicing

To prevent bodily injury when mounting or servicing this unit in a rack, you must take special precautions to ensure that the system remains stable. The following guidelines are provided to ensure your safety:

- This unit should be mounted at the bottom of the rack if it is the only unit in the rack.
- When mounting this unit in a partially filled rack, load the rack from the bottom to the top with the heaviest component at the bottom of the rack.
- If the rack is provided with stabilizing devices, install the stabilizers before mounting or servicing the unit in the rack.

**Warning Statement 1047**—Overheating Prevention

To reduce the risk of fire or bodily injury, do not operate the unit in an area that exceeds the maximum recommended ambient temperature of: 40°C



Caution To prevent loss of input power, ensure the total maximum loads on the circuits supplying power to the switch are within the current ratings for the wiring and breakers.



Note For AC input application, please refer to the statement below:

**Warning Statement 1005**—Circuit Breaker

This product relies on the building's installation for short-circuit (overcurrent) protection. Ensure that the protective devices is rated not greater than 20A (North America), 16A (Europe), and 13A (UK).

Network Equipment-Building System (NEBS) Statements

NEBS describes the environment of a typical United States Regional Bell Operating Company (RBOC) central office. NEBS is the most common set of safety, spatial, and environmental design standards applied to

telecommunications equipment in the United States. It is not a legal or regulatory requirement, but rather an industry requirement.



Note **Statement 7001**—ESD Mitigation

This equipment may be ESD sensitive. Always use an ESD ankle or wrist strap before handling equipment. Connect the equipment end of the ESD strap to an unfinished surface of the equipment chassis or to the ESD jack on the equipment if provided.



Warning **Statement 7003**—Shielded Cable Requirements for Intrabuilding Lightning Surge

The intrabuilding port(s) of the equipment or subassembly must use shielded intrabuilding cabling/wiring that is grounded at both ends.

The following port(s) are considered intrabuilding ports on this equipment:

The copper RJ45 Ethernet Ports.



Warning **Statement 7005**—Intrabuilding Lightning Surge and AC Power Fault

The intrabuilding port(s) of the equipment or subassembly must not be metallically connected to interfaces that connect to the outside plant (OSP) or its wiring. These interfaces are designed for use as intrabuilding interfaces only (Type 2 or Type 4 ports as described in GR-1089-CORE) and require isolation from the exposed OSP cabling. The addition of primary protectors is not sufficient protection to connect these interfaces metallically to OSP wiring.

This statement applies to the intrabuilding ports listed below:

The copper RJ45 Ethernet Ports.



Warning **Statement 7008**—Equipment Using Agreed Primary Protection

This product is intended to be protected by a surge protector that meets the applicable criteria of GR-974-CORE or GR-1361-CORE. Failure to use this appropriate surge protector could result in susceptibility to lightning surges or create a potential hazard due to power faults.



Note **Statement 7011**—Surge Protection Device Requirements for GR-1089 Antenna Ports

Protect equipment antenna ports, that are classified as Type 6 according to GR-1089-CORE, with lightning surge protectors that are rated at a minimum of 600 V peak surge of 1.2/50 uS duration.



Warning **Statement 7012**—Equipment Interfacing with AC Power Ports

Connect this equipment to AC mains that are provided with a surge protective device (SPD) at the service equipment that complies with NFPA 70, the National Electrical Code (NEC).



Note **Statement 7013**—Equipment Grounding Systems—Common Bonding Network (CBN)

This equipment is suitable for installations using the CBN.



Note **Statement 7014**—Installation Location Outside Plant (OSP)

This equipment is suitable for installation in OSP locations.



Note **Statement 7015**—Equipment Bonding and Grounding

When you use thread-forming screws to bond equipment to its mounting metalwork, remove any paint and nonconductive coatings and clean the joining surfaces. Apply an antioxidant compound before joining the surfaces between the equipment and mounting metalwork.



Note **Statement 7016**—Battery Return Conductor

Treat the battery return conductor of this equipment as DC-I.



Note **Statement 7018**—System Recover Time

The equipment is designed to boot up in less than 30 minutes provided the neighboring devices are fully operational.



Note **Statement 7019**—Equipment Grounding Systems—Isolated Bonding Network (IBN)

This equipment is suitable for installations using the IBN.



Note **Statement 8015**—Installation Location Network Telecommunications Facilities

This equipment is suitable for installation in network telecommunications facilities.



Note **Statement 8016**—Installation Location Where the National Electric Code (NEC) Applies

This equipment is suitable for installation in locations where the NEC applies.

Preparing to Install the Chassis

Before you can install the switch, you must verify the following:

- The installation site meets the following requirements as stated in Chapter 2:
 - Environmental requirements for temperature, humidity, altitude, and air particulates.
 - Cabinet or rack is installed and meets the requirements for the switch.



Note Jumper power cords are available for use in a cabinet.

- The rack is positioned so that you can install the switch with its cold air intakes positioned in a cold aisle.

If the fan and power supply modules are burgundy or red colored, you must install the chassis with its port side in a cold aisle. If the modules are blue colored, you must be able install the chassis with the fan modules in a cold aisle.

- Earth ground connection is close to the switch. You must be able to easily connect the switch directly to an earth ground or indirectly through a grounded rack.



Caution High leakage current. Earth connection essential before connecting to power supply.

- Site power meets the switch requirements. If you are using n+n redundancy, you must have two power sources within reach of the switch when it is installed in the cabinet or rack.

If available, you can use an uninterruptible power supply (UPS) to protect against power failures.



Caution Avoid UPS types that use ferroresonant technology. These UPS types can become unstable with systems such as the Cisco Nexus switches. These switches can have substantial current draw fluctuations because of fluctuating data traffic patterns.

Ensure that circuits are sized according to local and national codes. For North America, the power supply requires a 15-A or 20-A circuit.

**Caution**

To prevent loss of input power, ensure the total maximum loads on the circuits supplying power to the switch are within the current ratings for the wiring and breakers.

- There is adequate clearance around the rack to install the switch and to allow for unimpeded airflow.
- You have the following equipment in addition to the switch and the kits shipped with the switch:
 - Eight customer-supplied 12-24 or 10-32 screws (required for attaching slider rails and mounting bracket to the mounting rails)
 - Number 1 and number 2 Phillips screwdrivers with torque capability
 - 3/16-inch flat-blade screwdriver
 - Tape measure and level
 - ESD wrist strap or other grounding device (wrist strap can be found in the accessory kit)
 - Antistatic surface large enough to place the switch
 - Grounding cable (6 AWG recommended), sized according to local and national installation requirements; the required length depends on the proximity of the switch to proper grounding facilities
 - Crimping tool large enough to accommodate the girth of the grounding lug
 - Wire stripping tool

Unpacking and Inspecting the Chassis

**Caution**

When handling switch components, such as fan or power supply modules, wear a grounded ESD strap and handle the modules by their carrier edges only. To ground the ESD strap, make sure that it is attached to an earth ground, a grounded chassis, or a grounded rack.

**Tip**

Keep the shipping container in case the chassis requires shipping in the future.

**Note**

The switch is thoroughly inspected before shipment. If any damage occurred during transportation or any items are missing, contact your customer service representative immediately.

To inspect the switch, follow these steps:

-
- Step 1** Compare the shipment to the equipment list provided by your customer service representative and verify that you have received all items.
- Step 2** Check for damage and report any discrepancies or damage to your customer service representative. Have the following information ready:
- Invoice number of shipper (see the packing slip)
 - Model and serial number of the damaged unit
 - Description of damage
 - Effect of damage on the installation
 - Photos of the damaged shipping containers and damaged product
- Step 3** For dual direction airflow switches, check to be sure that all of the fan and power supply modules have the same airflow direction.
- Port-side intake airflow direction indicated with burgundy coloring
-

Installing the Chassis in a Four-Post Rack

This section describes the installation of the Cisco Nexus 9408 platform switch, into a four-post rack, using the N9K-C9400-RMK rack-mount kit.

Before moving or lifting the chassis, follow these guidelines:

- Ensure that there is adequate space around the switch for servicing and airflow.
- Never attempt to lift an object that is too heavy for you to lift by yourself.
- Ensure that you have solid footing. Distribute the weight of the switch is evenly between your feet.
- Lift the switch slowly, keeping your back straight. Lift with your legs, not with your back. Bend at the knees, not at the waist.



Warning **Statement 1091**—Installation by an Instructed Person

Only an instructed person or skilled person should be allowed to install, replace, or service this equipment. See statement 1089 for the definition of an instructed or skilled person.

There are no serviceable parts inside. To avoid risk of electric shock, do not open.



Warning Statement 1032—Lifting the Chassis

To prevent personal injury or damage to the chassis, never attempt to lift or tilt the chassis using the handles on modules, such as power supplies, fans, or cards. These types of handles are not designed to support the weight of the unit.



Warning Statement 1006—Chassis Warning for Rack-Mounting and Servicing

To prevent bodily injury when mounting or servicing this unit in a rack, you must take special precautions to ensure that the system remains stable. The following guidelines are provided to ensure your safety:

- This unit should be mounted at the bottom of the rack if it is the only unit in the rack.
 - When mounting this unit in a partially filled rack, load the rack from the bottom to the top with the heaviest component at the bottom of the rack.
 - If the rack is provided with stabilizing devices, install the stabilizers before mounting or servicing the unit in the rack.
-

Step 1

Attach two front-mount brackets to the sides of the chassis as follows:

- a) Align the two holes in one side of a front-mount bracket to the holes on the left or right side of the chassis as shown in the following figure.

Figure 1: Aligning and Attaching Front-Mount Brackets to the Chassis

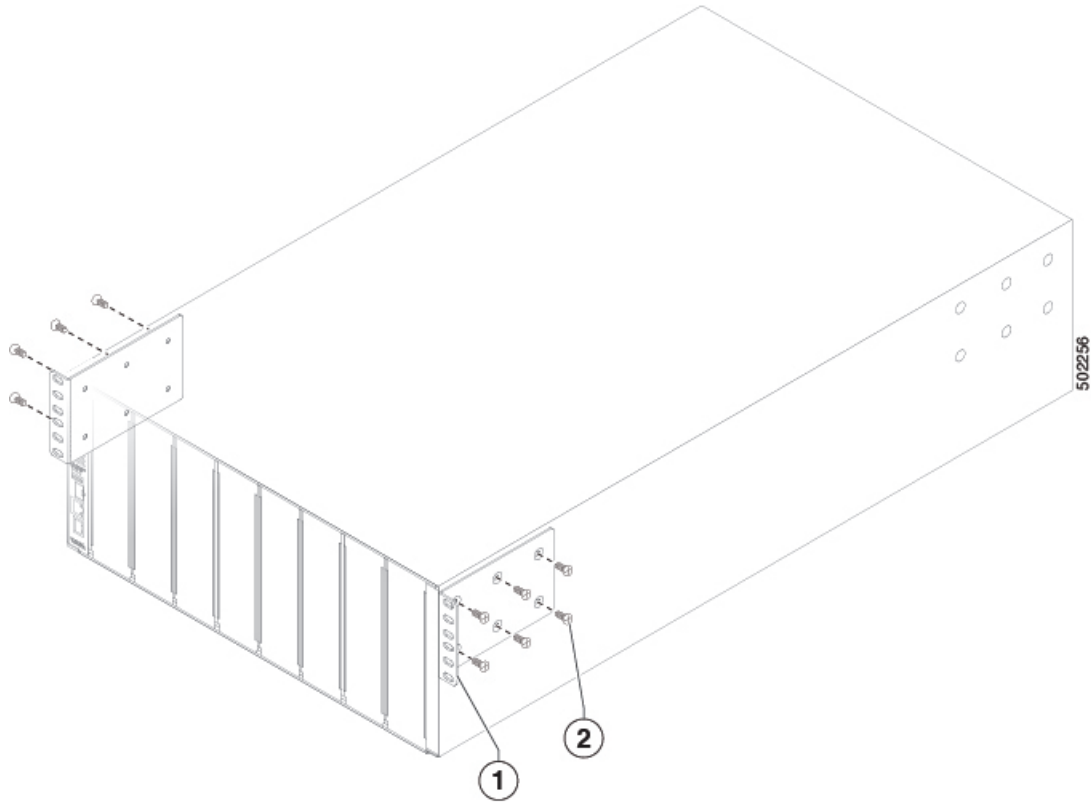

1	Front rack-mount bracket	2	M4 x 6-mm screws
---	--------------------------	---	------------------

- b) Use M4 x 6 mm screws to attach the bracket to the chassis and tighten each screw to 12 in-lb (1.36 N·m) of torque.
- c) Repeat Steps 1a and 1b to attach the other front-mount bracket to the other side of the chassis.

Step 2

Align the bottom-support rails so that they form a shelf for the chassis.

Note The bottom-support rails are not interchangeable. Use the one marked with [R] for the right, and with [L] for the left side of the rack.

Figure 2: Aligning the Bottom-Support Rails

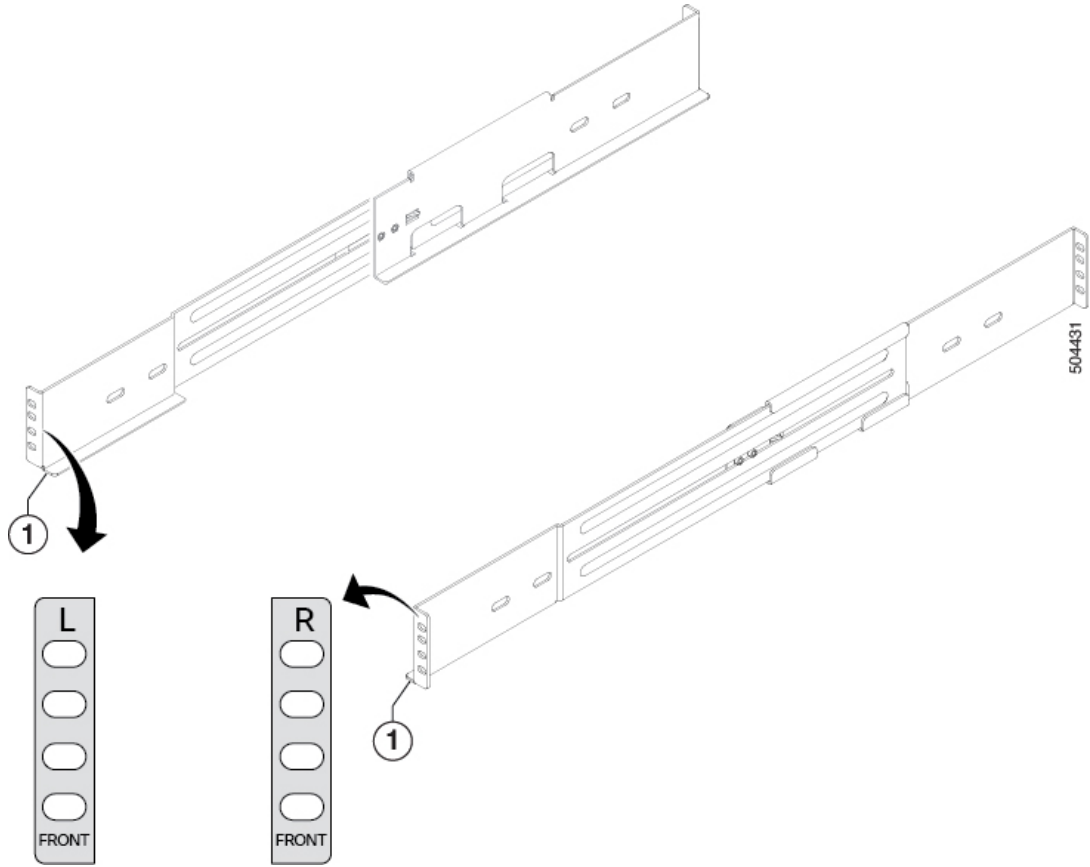

1	Bottom-support rail (2)	
---	-------------------------	--

Step 3

Attach the bottom-support rails on the rack as follows:

- a) Position an expanding set of bottom-support brackets on the rack with each end touching a vertical mounting rail on the front and rear of the rack as shown in the following figure.

Figure 3: Positioning the Bottom-Support Rails

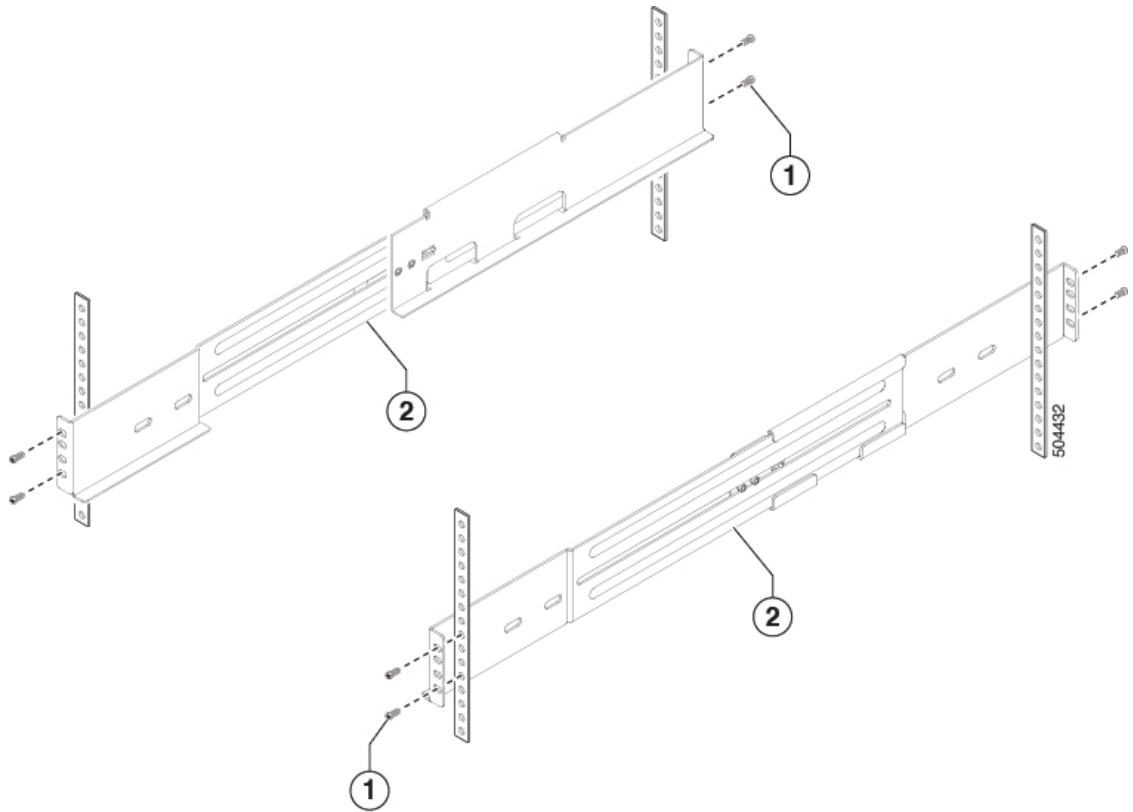

1	Screws holding the bottom-support bracket to the rack	2	The bottom-support brackets (2)
---	---	---	---------------------------------

- b) Holding the bottom-support rail level, attach the rail to the front and rear vertical mounting rails using four customer-supplied screws that are appropriate for the rack (use two screws for each vertical mounting rail), and tighten each screw to the appropriate torque setting for that screw.

Typically, you use one of the following types of screws and the associated torque settings when tightening them:

- M4 screws—Use 12 in-lb (1.36 N·m) of torque.
- M6 screws—Use 40 in-lb (4.5 N·m) of torque.
- 10-32 screws— Use 20 in-lb (2.26 N·m) of torque.

If the rack requires another type of screw, use the appropriate torque setting for that type of screw.

- c) Repeat Steps 3a and 3b to attach the other expanding bottom-support rail to the other side of the rack at the same level as the attached bottom-support rail.

Note Verify that the two sets of bottom-support rails are level with each other before going to the next step.

Step 4 Install the chassis in the rack as follows:

- a) Slide the power supply end of the chassis onto the installed bottom-support rails as shown in the following figure.

Note When sliding the chassis onto the bottom-support rails, proceed slowly and cautiously so that you don't damage the switch or support rails.

When you have fully pushed the chassis all the way onto the bottom-support rails, the chassis stops when the front-mount brackets touch the front vertical mounting rack.

Figure 4: Sliding the Chassis onto the Bottom-Support Rails

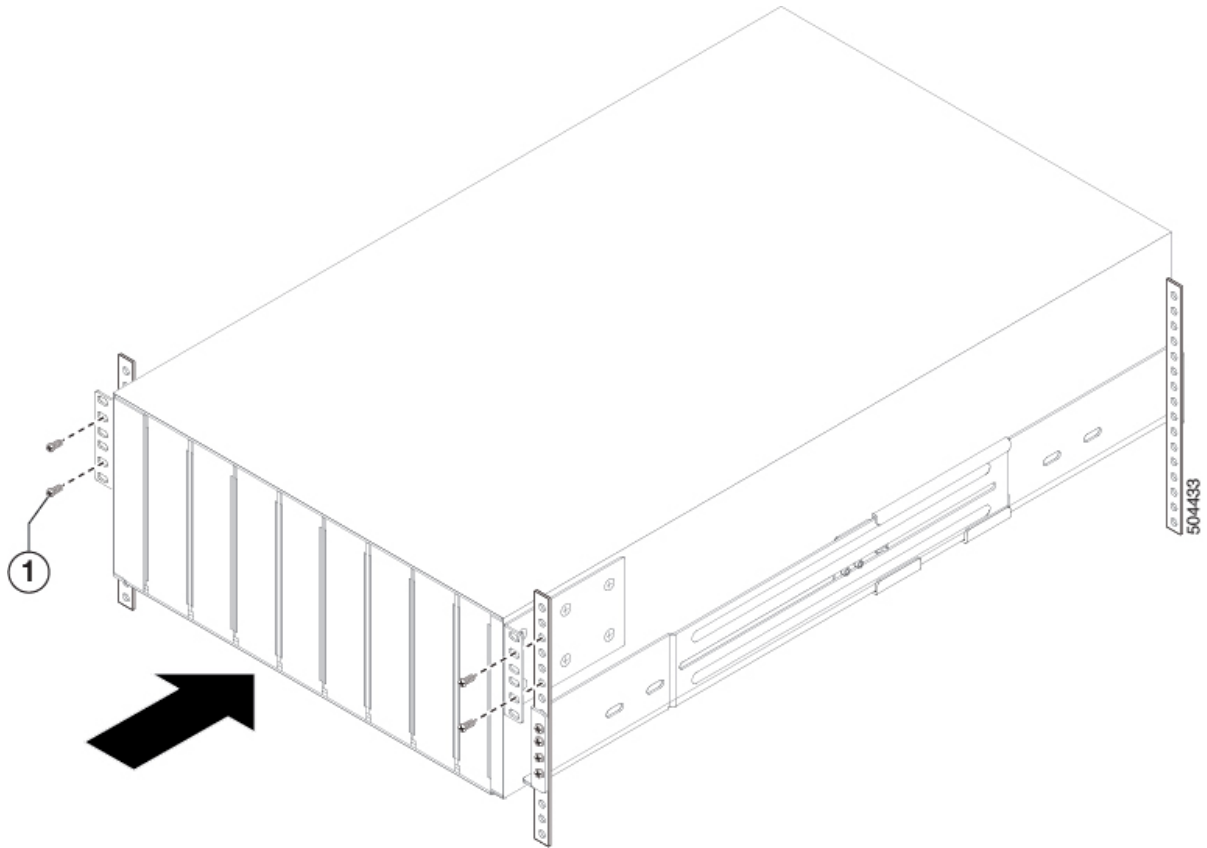

1	Rack-mount screw		
---	------------------	--	--

- b) Use screws that are appropriate for the rack to attach the front-mount brackets to the rack.

Typically, you use one of the following types of screws and the associated torque settings when tightening them:

- M4 screws—Use 12 in-lb (1.36 N·m) of torque.
- M6 screws—Use 40 in-lb (4.5 N·m) of torque.
- 10-32 screws— Use 20 in-lb (2.26 N·m) of torque.

If the rack requires another type of screw, use the appropriate torque setting for that type of screw.

Grounding the Chassis

The switch chassis is automatically grounded when you properly install the switch in a grounded rack with metal-to-metal connections between the switch and rack.

You can alternatively ground the chassis (this is required if the rack is not grounded) by attaching a customer-supplied grounding cable to the chassis grounding pad and the facility ground.



Note The location of the grounding pad on each switch can be found in the [Overview](#) section.



Note An electrical conducting path shall exist between the product chassis and the metal surface of the enclosure or rack in which it is mounted or to a grounding conductor. Electrical continuity shall be provided by using thread-forming type mounting screws that remove any paint or non-conductive coatings and establish a metal-to-metal contact. Any paint or other non-conductive coatings shall be removed on the surfaces between the mounting hardware and the enclosure or rack. The surfaces shall be cleaned and an antioxidant applied before installation.

The switch is grounded when you connect the chassis and the power supplies to the earth ground in the following ways:

- You connect the chassis (at its grounding pad) to the data center ground. If the rack is fully-bonded and grounded, you can ground the switch by connecting it to the rack.



Note The chassis ground connection is active even when the power supply modules have not been grounded or connected to the switch.



Warning Statement 1024—Ground Conductor

This equipment must be grounded. Never defeat the ground conductor or operate the equipment in the absence of a suitably installed ground conductor. Contact the appropriate electrical inspection authority or an electrician if you are uncertain that suitable grounding is available.



Warning Statement 1046—Installing or Replacing the Unit

When installing or replacing the unit, the ground connection must always be made first and disconnected last

Before you begin

Before you can ground the chassis, you must have a connection to the earth ground for the data center building. If you installed the switch chassis into a bonded rack (see the rack manufacturer's instructions for more information) that now has a connection to the data center earth ground, you can ground the chassis by installing it into the rack. Otherwise, you must connect the chassis grounding pad directly to the data center ground.

Step 1

Use a wire-stripping tool to remove approximately 0.75 inches (19 mm) of the covering from the end of the grounding wire.

- Step 2** Insert the stripped end of the grounding wire into the open end of the grounding lug, and use a crimping tool to crimp the lug to the wire (see Callout 2 in the following figure). Verify that the ground wire is securely attached to the grounding lug by attempting to pull the wire out of the crimped lug.

Figure 5: Grounding the Chassis

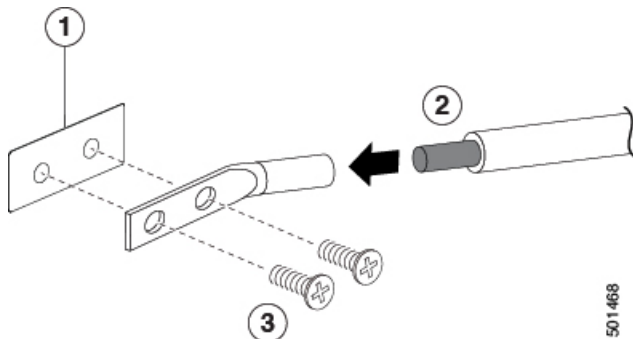

1	Chassis grounding pad	3	Two M4 screws used to secure the grounding lug to the chassis
2	Grounding cable, with 0.75 in. (19 mm) of insulation stripped from one end, inserted into the grounding lug and crimped in place		

- Step 3** Secure the grounding lug to the chassis grounding pad with two M4 screws (see Callouts 1 and 3 in the previous figure), and tighten the screws to 12 in lb (1.36 N·m) of torque.
- Step 4** Prepare the other end of the grounding wire and connect it to an appropriate grounding point in your site to ensure an adequate earth ground for the switch. If the rack is fully bonded and grounded, connect the grounding wire as explained in the documentation provided by the vendor for the rack.

Starting the Switch



Warning **Statement 1005**—Circuit Breaker

This product relies on the building's installation for short-circuit (overcurrent) protection. To reduce risk of electric shock or fire, ensure that the protective device is rated not greater than:



Note This device is designed to boot-up in less than 30 minutes, provided the neighboring devices are fully operational.

To power up the switch, follow these steps:

Before you begin

- Verify that the switch is fully installed and secured to a rack.
- Verify that the switch is adequately grounded to the facility earth ground or to a grounded rack.
- Verify that all of the fan and power supply modules are installed in the chassis. If the chassis has less than 4 power supplies, there must be a blank module (NXA-PS-BLANK) in the open power supply slot to maintain the designed airflow.

-
- Step 1** If the switch has AC power supplies, connect those power supplies to an AC power source as follows:
- a) Verify that the AC power source is turned off at the circuit breaker.
 - b) Plug the power cable into the power receptacle on the power supply.
 - c) Attach the other end of the power cable to the AC power source.
 - d) Turn on the power at the circuit breaker.
 - e) Verify that the power supply is functioning by making sure that the OK LED turns green and the FAULT LED is off.
- Step 2** Listen for the fans; they should begin operating when the power cable is plugged in.
- Step 3** After the switch boots, verify that the following LEDs are on:
- Power supply LED—lit and green
If not green, try removing the module part way from its slot and reinstalling it.
 - Fan LED—lit and green
If not green, try removing the module part way from its slot and reinstalling it.
 - System Status LED—lit and green (if this LED is orange or red, then one or more environmental monitors is reporting a problem.)
 - Link LEDs for the Ethernet connector—Off
-

