



Replacing Modules

- [Replacing a 4 \(RU\) Fan Module, on page 1](#)
- [Replacing an AC Power Supply, on page 2](#)
- [Replacing a Supervisor Module, on page 3](#)
- [Installing or Replacing a Line-Card Expansion Module \(LEM\), on page 6](#)
- [Replacing a Switch Card, on page 8](#)
- [Fiber Optic Removal Using the Optics Extraction Tool , on page 11](#)

Replacing a 4 (RU) Fan Module

The fan module is designed to be removed and replaced while the system is operating without causing an electrical hazard or damage to the system if the replacement is performed within one minute.

If you do not have the appropriate replacement fan module, leave the original fan module in its slot to preserve the designed airflow for the switch until you have the replacement fan module. The module number can be found on the chassis.



Caution The fans might be turning when you remove the fan assembly from the chassis. Keep fingers, screwdrivers, and other objects away from the openings in the fan assembly's housing.

Before you begin

- Verify that you have an ESD wrist strap or other device to prevent ESD damage for components that you touch.
- Verify that you have an antistatic surface or bag for placing the fan module that you remove from the chassis.
- Verify that the replacement fan module has the correct direction of airflow (it has the same coloring as the other fan and power supply modules in the same chassis).

Step 1 Attach an ESD wrist strap or other ESD device to your body and an earth ground to prevent ESD damage.

You can attach the ESD device to any earth ground or grounded object, such as a grounded rack or ground connection on a chassis.

Step 2 Remove the fan module that you are replacing as follows:

- a) On the fan module that you are removing, unscrew the two captive screws on the front of the fan module until each screw is free of the chassis.
- b) Holding the handle, pull the module out of the chassis and set it on an antistatic surface or in an antistatic bag.

Caution Do not touch the electrical connectors on the back side of the module and prevent anything else from coming into contact with and damaging the connectors.

Step 3 Install the replacement fan module as follows:

- a) Hold the fan module with two hands. One hand holding its handle, and one hand supporting the weight of the fan module. Align the back of the fan module (the side with the electrical connectors) to the open fan slot in the chassis.
- b) Slide the fan module into the slot until it clicks in place.
- c) Tighten the fan module captive screws.
- d) Verify that the Status (STS) LED turns on and becomes green.

Replacing an AC Power Supply

You can replace an AC power supply during operations so long as there is another power supply installed and operating during the replacement. The switch requires two power supplies for operations, so you can hot swap the redundant power supply during operations. If there are only two power supplies installed in the chassis, you can replace one by installing the new power supply in the open power supply slot before removing the other power supply. The module number can be found on the chassis.



Note This switch supports port-side intake power supplies only (NXA-PAC-2KW-PI)

Before you begin

- Verify that you have an ESD wrist strap or other device to prevent ESD damage to the components that you touch.
- Verify that you have an antistatic surface or bag for placing the power supply module that you remove from the chassis.
- Verify that the replacement power supply module has the correct direction of airflow (it has the same coloring as the other fan and power supply modules in the same chassis). Otherwise the switch can overheat and shut down.

Step 1 Attach an ESD wrist strap or other ESD device to your body and an earth ground to prevent ESD damage.

You can attach the ESD device to any earth ground or grounded object, such as a grounded rack or ground connection on a chassis.

Step 2 Remove the power supply as follows:

- a) Pull the power cord out from the power receptacle on the power supply to be removed and verify that the OK LED turns off.

- b) Remove the power supply from the chassis by pushing and holding its thumb latch to the left and pulling the power supply part way out of the chassis.
- c) Place your other hand under the power supply to support it while you slide it out of the chassis.
Either place the power supply on an antistatic surface or pack it in its packing materials.
- d) If the power supply slot is to remain empty, install a blank power supply filler panel (part number NXA-PS-BLANK).

Step 3

Install the replacement power supply as follows:

- a) Holding the replacement power supply with one hand underneath the module and the other hand holding the handle, align the back end of the power supply (the end with the electrical connections) to the open power supply slot and slide the power supply all the way into the slot until it clicks into place.
- b) Test the installation by trying to pull the power supply out of the slot without using the release latch.

If the power supply does not move out of place, it is secured in the slot. If the power supply moves, press it all the way into the slot until it clicks in place.

Step 4

Connect the new power supply to an AC power source as follows:

- a) Attach the power cable to the electrical outlet on the front of the power supply.
- b) Connect the other end of the power cable to an AC power source.
 - For no power redundancy, connect one power supply to one power source.
 - For n+1 redundancy, connect two power supplies to one or two power sources.
 - For n+n redundancy, connect each of two power supplies to a different power source.

Note Depending on the outlet receptacle on your power distribution unit, you might need the optional jumper cable to connect the switch to your outlet receptacle.

- c) Verify that the power supply is operational by checking that the power supply OK LED is green.

Replacing a Supervisor Module

This procedure can proceed without unplugging the switch.



Warning **Statement 1034**—Backplane Voltage

Hazardous voltage or energy is present on the backplane when the system is operating. Use caution when servicing.



Warning **Statement 1051**—Laser Radiation

Invisible laser radiation may be emitted from disconnected fibers or connectors. Do not stare into beams or view directly with optical instruments.

Before you begin

- Wear electrostatic discharge (ESD) wrist strap or other ESD protective device while handling modules.
 - Prepare an antistatic surface or packing materials for each module that you remove from the chassis.
-

Step 1 Open the packaging for the new module and inspect the module for damage.

For a damaged module, contact the Technical Assistance Center (TAC).

Step 2 If you are replacing a module that is currently in the chassis, remove the existing module from the chassis by following these steps:

Note Disconnect and label each of the interface cables from the module.

- a) Loosen the thumb-screw on the module to release the module from the chassis as shown in the following figure.
- b) Press the latch down, to release the latch from the chassis as shown in the following figure.
- c) Rotate the latch away from the module to disengage from the chassis as shown in the following figure.
- d) Holding the latch release lever handle, pull the module out of the chassis as shown in the following figure.

Figure 1: Supervisor Module Latch Release Lever

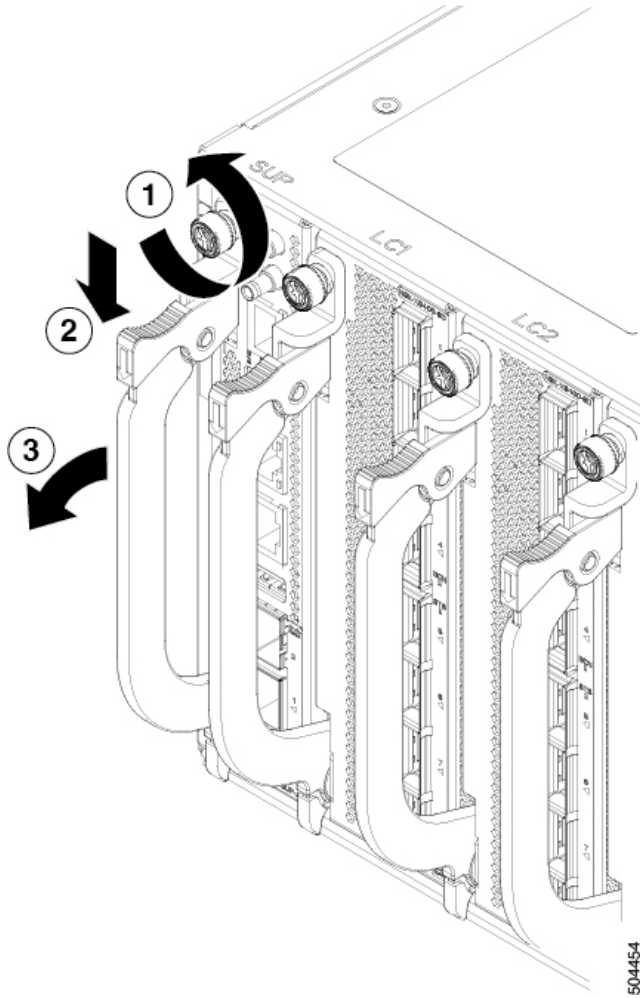

1	Loosen the thumb-screw on the module.	2	Press the latch down to release the latch from the chassis.
3	Rotate the latch away from the module to disengage from the chassis.	4	Pull the module out of the chassis.

Step 3

To install the module, follow these steps:

- a) Make sure that the lever is in the fully open position.
- b) Hold the module with one hand and place your other hand under the module to support its weight.
- c) Align the module with the open slot and gently slide the module into the slot until the lever's clamp engages with the chassis. Then rotate the lever up and toward the chassis until it clicks into the fully closed position .
- d) Tighten the module thumb-screws.

Note Attach each interface cable to the appropriate port on the module. Use the label on each cable to determine to which port each cable attaches.

Installing or Replacing a Line-Card Expansion Module (LEM)

The switch can operate with one or more Line-card Expansion Modules (LEMs) installed in the chassis. If there is at least one LEM installed and operating in the chassis, you can replace another LEM or install a new LEM in an empty slot. The LEMs are hot-swappable.



Note **Limitation:** N9K-X9400-16W has a limitation on link bring up for 10G/40G and 10G/100G when connecting ports that are next to each other.

if port 1 is connected with 10G, and if 40G or 100G is connected in port2 then port 2 will be `hw-disabled`. To recover port 2 from `hw-disabled`, you need to remove 10G from port 1 and you need to do OIR once on port-2

```
Eth4/3 -- hwdisabled trunk full inherit QSFP-H40G-CU5M
Eth4/4 -- connected routed full 10G SFP-H10GB-AOC1M
```

```
ifav132-leaf18-sl# show int ethernet 4/3-4 status
Eth4/3 -- out-of-ser trunk full 40G QSFP-H40G-CU5M
Eth4/4 -- hwdisabled routed full inherit SFP-H10GB-AOC1M
```

```
ifav132-leaf18-sl# show int ethernet 6/7-8 status
```

```
-----
Port Name Status Vlan Duplex Speed Type
-----
```

```
Eth6/7 -- out-of-ser trunk full 10G 10Gbase-SR
Eth6/8 -- hwdisabled trunk full inherit QSFP-100G-CWDM4
ifav132-leaf18-sl# show int ethernet 6/7-8 status
```

```
-----
Port Name Status Vlan Duplex Speed Type
-----
```

```
Eth6/7 -- hwdisabled trunk full inherit 10Gbase-SR
Eth6/8 -- out-of-ser trunk full 100G QSFP-100G-CWDM4
-----
```



Caution After a LEM is removed, you must wait at least 10 seconds before you insert a new one. Once the LEM is inserted, the `retimer init` program will be started in MIFPGA. Any removal or disturbance would cause `retimer` cannot access LEM MIFPGA and a crash can happen.



Warning **Statement 1034**—Backplane Voltage

Hazardous voltage or energy is present on the backplane when the system is operating. Use caution when servicing.



Warning Statement 1051—Laser Radiation

Invisible laser radiation may be emitted from disconnected fibers or connectors. Do not stare into beams or view directly with optical instruments.

Before you begin

- Wear electrostatic discharge (ESD) wrist strap or other ESD protective device while handling modules.
- Prepare an antistatic surface or packing materials for each module that you remove from the chassis.

Step 1 Open the packaging for the new LEM and inspect the module for damage.

For a damaged module, contact the Technical Assistance Center (TAC).

Step 2 If you are installing the module in a slot with a blank module, remove the blank module (N9K-C9400-BLK) that is already in that slot.

Step 3 If you are replacing a module that is currently in the chassis, remove the existing module from the chassis by following these steps:

Note Disconnect and label each of the interface cables from the module.

- a) Loosen the thumb-screw on the LEM to release the LEM from the chassis as shown in the following figure.
- b) Press the latch down, to release the latch from the chassis as shown in the following figure.
- c) Rotate the latch away from the module to disengage from the chassis as shown in the following figure.
- d) Holding the latch release lever handle, pull the module out of the chassis as shown in the following figure.

Figure 2: Line-Card Expansion Module Latch Release Lever

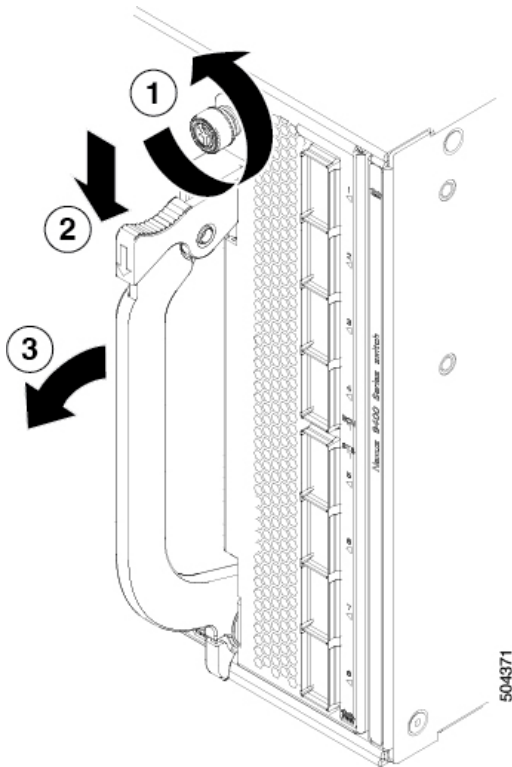

1	Loosen the thumb-screw on the LEM.	2	Press the latch down to release the latch from the chassis.
3	Rotate the latch away from the module to disengage from the chassis.	4	Pull the module out of the chassis.

Step 4 To install the module, follow these steps:

- a) Make sure that the LEM lever is in the fully open position.
- b) Hold the module with one hand and place your other hand under the module to support its weight.
- c) Align the module with the open slot and gently slide the module into the slot until the lever's clamp engages with the chassis. Then rotate the lever up and toward the chassis until it clicks into the fully closed position .
- d) Tighten the LEM thumb-screw.

Note Attach each interface cable to the appropriate port on the module. Use the label on each cable to determine to which port each cable attaches.

Replacing a Switch Card

The Switch Card is hot-swappable. It is not necessary to shut down the switch before replacing the module.



Warning Statement 1034—Backplane Voltage

Hazardous voltage or energy is present on the backplane when the system is operating. Use caution when servicing.

Before you begin

- Wear electrostatic discharge (ESD) wrist strap or other ESD protective device while handling the module.
- Prepare an antistatic surface or packing materials for the module that you remove from the chassis.

Step 1 Open the packaging for the new Switch Card and inspect the module for damage.

For a damaged module, contact the Technical Assistance Center (TAC).

Step 2 To remove the module follow these steps:

- a) Loosen the thumb screws that attach the module to the chassis (4), as shown in the following figure.
- b) Push the lever button (2) to release the lever, as shown in the following figure.
- c) Disengage the lever (2) by pulling it out and away from the chassis, as shown in the following figure.
- d) Carefully remove the module.

Figure 3: Switch Card Replacement

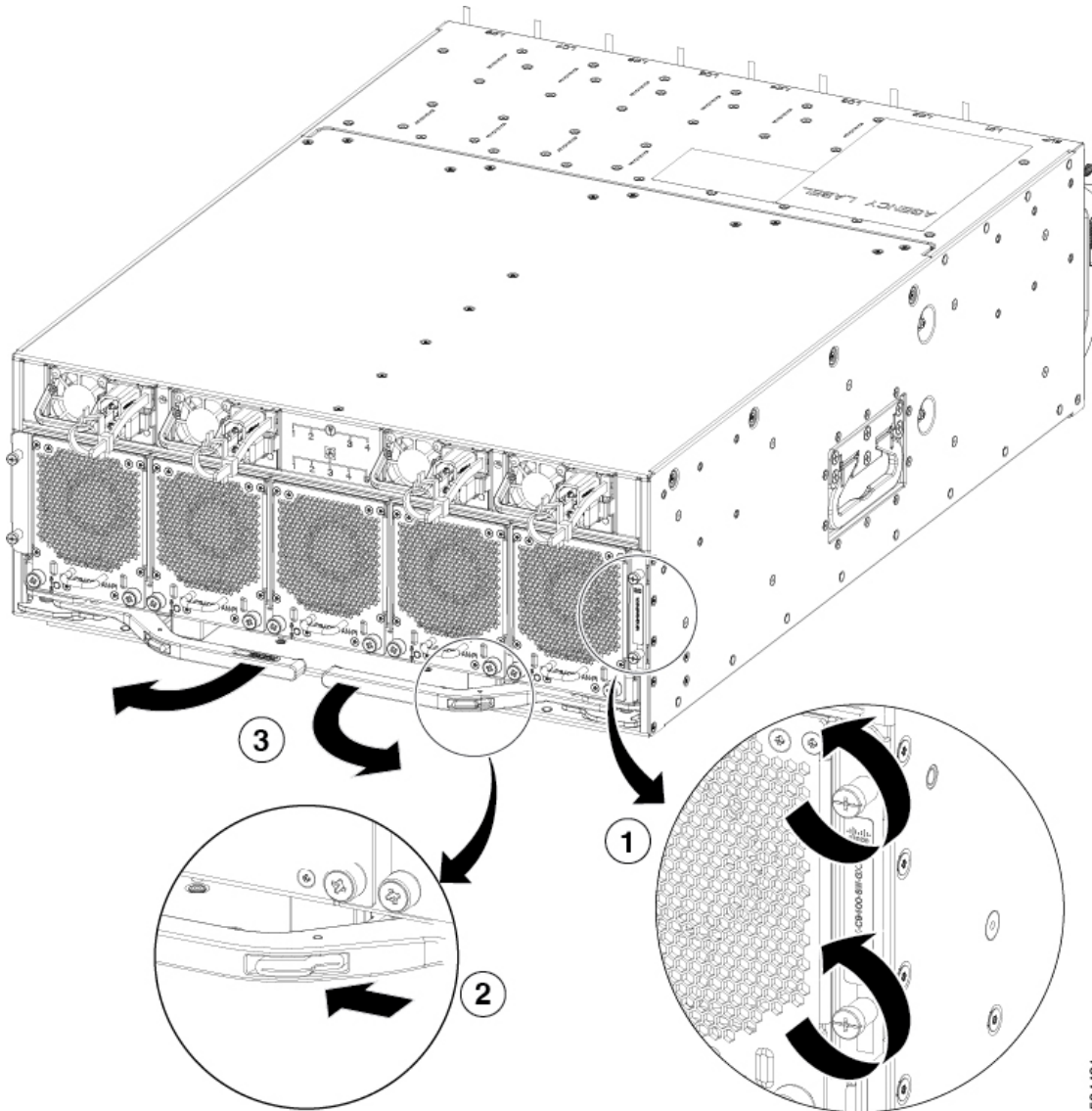

504421

1	Loosen the thumb screws (2 each side of the chassis)	2	Push the lever button (1 each lever)
3	Disengage the lever (2)		

Step 3

To install the module, follow these steps:

- a) Make sure that each lever is in the fully open position.
- b) Use both hands, one on the left side and one on the right side of the module, to support its weight.
- c) Align the module with the open slot and gently slide the module into the slot until the lever's clamp touches the chassis. Then engage the levers by pushing them toward the chassis until it clicks into place, reaching the fully closed position..

- d) Tightening the thumb screws.
-

Fiber Optic Removal Using the Optics Extraction Tool

Management port fiber optics cannot be removed unless the Supervisor LEM ejector is pulled out. This will cause a Supervisor reset.

Before you begin

Ensure that before you handle any switch components, you are wearing a grounded electrostatic discharge (ESD) strap. To ground the strap, attach it directly to earth ground or to a grounded rack or chassis. There must be a metal-to-metal connection to earth ground.

Step 1 Remove the fiber-optic cables from the transceiver module before removing the transceiver module.

Step 2 Use the optics extraction tool to carefully disengage the latch and remove the transceiver module (see the following

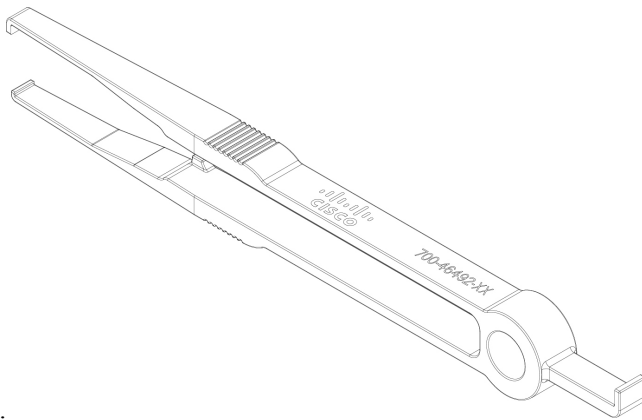

image).

Step 3 Place the transceiver module in an antistatic bag or other protective environment.
