



## Configuring and Managing VSANs

---

You can achieve higher security and greater stability in Fibre Channel fabrics by using virtual SANs (VSANs) on Cisco MDS 9000 Family switches and Cisco Nexus 5000 Series switches. VSANs provide isolation among devices that are physically connected to the same fabric. With VSANs you can create multiple logical SANs over a common physical infrastructure. Each VSAN can contain up to 239 switches and has an independent address space that allows identical Fibre Channel IDs (FC IDs) to be used simultaneously in different VSANs. This chapter includes the following sections:

- [About VSANs, page 2-1](#)
- [VSAN Configuration, page 2-5](#)
- [Displaying Static VSAN Configuration, page 2-11](#)
- [Default Settings, page 2-12](#)
- [Displaying Fabric Switch Information, page 2-13](#)

### About VSANs

A VSAN is a virtual storage area network (SAN). A SAN is a dedicated network that interconnects hosts and storage devices primarily to exchange SCSI traffic. In SANs, you use the physical links to make these interconnections. A set of protocols run over the SAN to handle routing, naming, and zoning. You can design multiple SANs with different topologies.

With the introduction of VSANs, the network administrator can build a single topology containing switches, links, and one or more VSANs. Each VSAN in this topology has the same behavior and property of a SAN. A VSAN has the following additional features:

- Multiple VSANs can share the same physical topology.
- The same Fibre Channel IDs (FC IDs) can be assigned to a host in another VSAN, thus increasing VSAN scalability.
- Every instance of a VSAN runs all required protocols such as FSPF, domain manager, and zoning.
- Fabric-related configurations in one VSAN do not affect the associated traffic in another VSAN.
- Events causing traffic disruptions in one VSAN are contained within that VSAN and are not propagated to other VSANs.

This section describes VSANs and includes the following topics:

- [VSANs Topologies, page 2-2](#)
- [VSAN Advantages, page 2-3](#)

- [VSANs Versus Zones, page 2-4](#)

## VSANs Topologies

The switch icons shown in both [Figure 2-1](#) and [Figure 2-2](#) indicate that these features apply to any switch in the Cisco MDS 9000 Family.

[Figure 2-1](#) shows a fabric with three switches, one on each floor. The geographic location of the switches and the attached devices is independent of their segmentation into logical VSANs. No communication between VSANs is possible. Within each VSAN, all members can talk to one another.

**Figure 2-1** Logical VSAN Segmentation

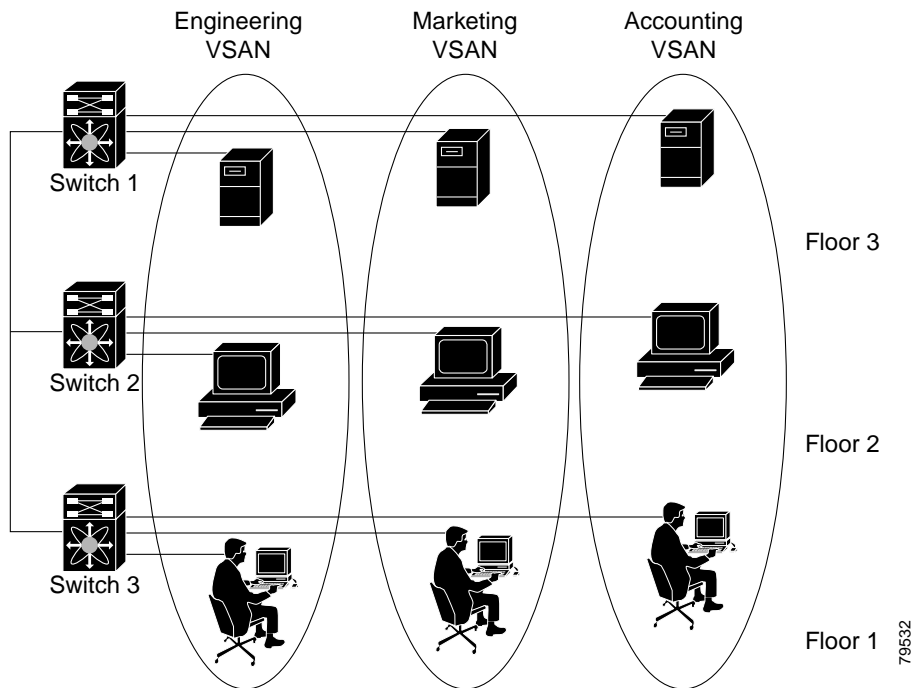

[Figure 2-2](#) shows a physical Fibre Channel switching infrastructure with two defined VSANs: VSAN 2 (dashed) and VSAN 7 (solid). VSAN 2 includes hosts H1 and H2, application servers AS2 and AS3, and storage arrays SA1 and SA4. VSAN 7 connects H3, AS1, SA2, and SA3.

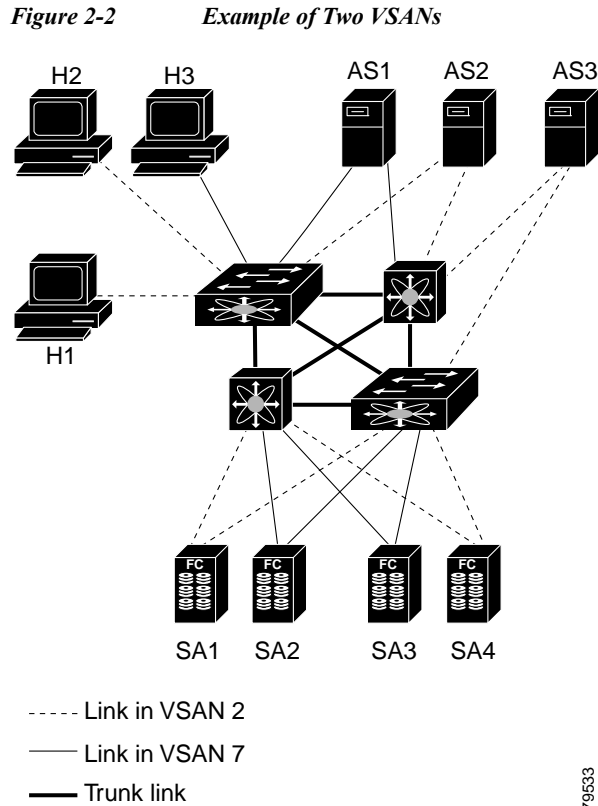

The four switches in this network are interconnected by trunk links that carry both VSAN 2 and VSAN 7 traffic. The inter-switch topology of both VSAN 2 and VSAN 7 are identical. This is not a requirement and a network administrator can enable certain VSANs on certain links to create different VSAN topologies.

Without VSANs, a network administrator would need separate switches and links for separate SANs. By enabling VSANs, the same switches and links may be shared by multiple VSANs. VSANs allow SANs to be built on port granularity instead of switch granularity. [Figure 2-2](#) illustrates that a VSAN is a group of hosts or storage devices that communicate with each other using a virtual topology defined on the physical SAN.

The criteria for creating such groups differ based on the VSAN topology:

- VSANs can separate traffic based on the following requirements:
  - Different customers in storage provider data centers
  - Production or test in an enterprise network
  - Low and high security requirements
  - Backup traffic on separate VSANs
  - Replicating data from user traffic
- VSANs can meet the needs of a particular department or application.

## VSAN Advantages

VSANs offer the following advantages:

- Traffic isolation—Traffic is contained within VSAN boundaries and devices reside only in one VSAN ensuring absolute separation between user groups, if desired.
- Scalability—VSANs are overlaid on top of a single physical fabric. The ability to create several logical VSAN layers increases the scalability of the SAN.
- Per VSAN fabric services—Replication of fabric services on a per VSAN basis provides increased scalability and availability.
- Redundancy—Several VSANs created on the same physical SAN ensure redundancy. If one VSAN fails, redundant protection (to another VSAN in the same physical SAN) is configured using a backup path between the host and the device.
- Ease of configuration—Users can be added, moved, or changed between VSANs without changing the physical structure of a SAN. Moving a device from one VSAN to another only requires configuration at the port level, not at a physical level.

Up to 256 VSANs can be configured in a switch. Of these, one is a default VSAN (VSAN 1), and another is an isolated VSAN (VSAN 4094). User-specified VSAN IDs range from 2 to 4093.

## VSANs Versus Zones

You can define multiple zones in a VSAN. Because two VSANs are equivalent to two unconnected SANs, zone A on VSAN 1 is different and separate from zone A in VSAN 2. [Table 2-1](#) lists the differences between VSANs and zones.

**Table 2-1** VSAN and Zone Comparison

VSAN Characteristic	Zone Characteristic
VSANs equal SANs with routing, naming, and zoning protocols.	Routing, naming, and zoning protocols are not available on a per-zone basis.
—	Zones are always contained within a VSAN. Zones never span two VSANs.
VSANs limit unicast, multicast, and broadcast traffic.	Zones limit unicast traffic.
Membership is typically defined using the VSAN ID to Fx ports.	Membership is typically defined by the pWWN.
An HBA or a storage device can belong only to a single VSAN—the VSAN associated with the Fx port.	An HBA or storage device can belong to multiple zones.
VSANs enforce membership at each E port, source port, and destination port.	Zones enforce membership only at the source and destination ports.
VSANs are defined for larger environments (storage service providers).	Zones are defined for a set of initiators and targets not visible outside the zone.
VSANs encompass the entire fabric.	Zones are configured at the fabric edge.

[Figure 2-3](#) shows the possible relationships between VSANs and zones. In VSAN 2, three zones are defined: zone A, zone B, and zone C. Zone C overlaps both zone A and zone B as permitted by Fibre Channel standards. In VSAN 7, two zones are defined: zone A and zone D. No zone crosses the VSAN boundary—they are completely contained within the VSAN. Zone A defined in VSAN 2 is different and separate from zone A defined in VSAN 7.

Figure 2-3 VSANS with Zoning

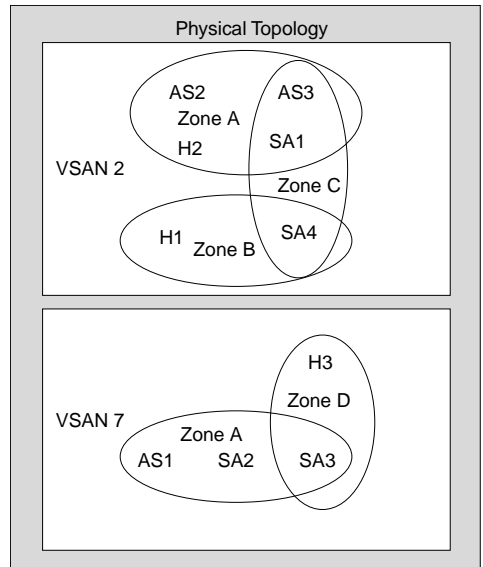

## VSAN Configuration

VSANs have the following attributes:

- **VSAN ID**—The VSAN ID identifies the VSAN as the default VSAN (VSAN 1), user-defined VSANs (VSAN 2 to 4093), and the isolated VSAN (VSAN 4094).
- **State**—The administrative state of a VSAN can be configured to an active (default) or suspended state. Once VSANs are created, they may exist in various conditions or states.
  - The active state of a VSAN indicates that the VSAN is configured and enabled. By enabling a VSAN, you activate the services for that VSAN.
  - The suspended state of a VSAN indicates that the VSAN is configured but not enabled. If a port is configured in this VSAN, it is disabled. Use this state to deactivate a VSAN without losing the VSAN's configuration. All ports in a suspended VSAN are disabled. By suspending a VSAN, you can preconfigure all the VSAN parameters for the whole fabric and activate the VSAN immediately.
- **VSAN name**—This text string identifies the VSAN for management purposes. The name can be from 1 to 32 characters long and it must be unique across all VSANs. By default, the VSAN name is a concatenation of VSAN and a four-digit string representing the VSAN ID. For example, the default name for VSAN 3 is VSAN0003.



**Note** A VSAN name must be unique.

- **Load balancing attributes**—These attributes indicate the use of the source-destination ID (src-dst-id) or the originator exchange OX ID (src-dst-ox-id, the default) for load balancing path selection.



---

**Note** OX ID based load balancing of IVR traffic from IVR-enabled switches is not supported on Generation 1 switching modules. OX ID based load balancing of IVR traffic from a non-IVR MDS switch should work. Generation 2 switching modules support OX ID based load balancing of IVR traffic from IVR-enabled switches.

---

This section describes how to create and configure VSANs and includes the following topics:

- [Reserved VSAN Range and Isolated VSAN Range Guidelines, page 2-6](#)
- [Creating VSANs Statically, page 2-6](#)
- [Port VSAN Membership, page 2-7](#)
- [Assigning Static Port VSAN Membership, page 2-7](#)
- [Displaying VSAN Static Membership, page 2-8](#)
- [Default VSAN, page 2-9](#)
- [Isolated VSAN, page 2-9](#)
- [Displaying Isolated VSAN Membership, page 2-9](#)
- [Operational State of a VSAN, page 2-9](#)
- [Static VSAN Deletion, page 2-9](#)
- [Deleting Static VSANs, page 2-10](#)
- [Load Balancing, page 2-11](#)
- [Configuring Load Balancing, page 2-11](#)
- [Interop Mode, page 2-11](#)
- [FICON VSANs, page 2-11](#)

## Reserved VSAN Range and Isolated VSAN Range Guidelines

On an NPV switch with a trunking configuration on any interface, or on a regular switch where the `port-channel-trunk` command is issued to enable the Trunking F Port Channels feature, follow these configuration guidelines for reserved VSANs and the isolated VSAN:

- If trunk mode is on for any of the interfaces or NP Port Channel is up, the reserved VSANs are 3840 to 4078, and they are not available for user configuration.
- The Exchange Virtual Fabric Protocol (EVFP) isolated VSAN is 4079, and it is not available for user configuration.

## VSAN Creation

A VSAN is in the operational state if the VSAN is active and at least one port is up. This state indicates that traffic can pass through this VSAN. This state cannot be configured.

## Creating VSANs Statically

You cannot configure any application-specific parameters for a VSAN before creating the VSAN.

## Creating VSANs

To create VSANs, follow these steps:

	Command	Purpose
Step 1	switch# <b>config t</b>	Enters configuration mode.
Step 2	switch(config)# <b>vsan database</b> switch(config-vsan-db)#	Configures the database for a VSAN. Application specific VSAN parameters cannot be configured from this prompt.
Step 3	switch(config-vsan-db)# <b>vsan 2</b>	Creates a VSAN with the specified ID (2) if that VSAN does not exist already.
Step 4	switch(config-vsan-db)# <b>vsan 2 name TechDoc</b> updated vsan 2	Updates the VSAN with the assigned name (TechDoc).
Step 5	switch(config-vsan-db)# <b>vsan 2 suspend</b>	Suspends the selected VSAN.
Step 6	switch(config-vsan-db)# <b>no vsan 2 suspend</b>	Negates the <b>suspend</b> command issued in the previous step.
Step 7	switch(config-vsan-db)# <b>end</b> switch#	Returns you to EXEC mode.

## Port VSAN Membership

Port VSAN membership on the switch is assigned on a port-by-port basis. By default, each port belongs to the default VSAN. You can assign VSAN membership to ports using one of two methods:

- Statically—By assigning VSANs to ports.  
See the [“Assigning Static Port VSAN Membership”](#) section on page 2-7.
- Dynamically—By assigning VSANs based on the device WWN. This method is referred to as dynamic port VSAN membership (DPVM).  
See [Chapter 3, “Creating Dynamic VSANs.”](#)

Trunking ports have an associated list of VSANs that are part of an allowed list (refer to the *Cisco MDS 9000 Family NX-OS Interfaces Configuration Guide*).

## Assigning Static Port VSAN Membership

To statically assign VSAN membership for an interface port, follow these steps:

	Command	Purpose
Step 1	switch# <b>config t</b>	Enters configuration mode.
Step 2	switch(config)# <b>vsan database</b> switch(config-vsan-db)#	Configures the database for a VSAN.
Step 3	switch(config-vsan-db)# <b>vsan 2</b>	Creates a VSAN with the specified ID (2) if that VSAN does not exist already.
Step 4	switch(config-vsan-db)# <b>vsan 2 interface fc1/8</b>	Assigns the membership of the fc1/8 interface to the specified VSAN (VSAN 2).

	Command	Purpose
Step 5	<code>switch(config-vsan-db)# vsan 7</code>	Creates another VSAN with the specified ID (7) if that VSAN does not exist already.
Step 6	<code>switch(config-vsan-db)# vsan 7 interface fc1/8</code>	Updates the membership information of the interface to reflect the changed VSAN.
	<code>switch(config-vsan-db)# vsan 1 interface fc1/8</code>	Removes the interface fc1/8 from VSAN 7 to VSAN 1( the default VSAN).  To remove the VSAN membership of interface fc1/8 from VSAN 7, you should define the VSAN membership of fc1/8 to another VSAN. The best practice is to assign it back to VSAN 1.

## Displaying VSAN Static Membership

To display the VSAN static membership information, use the **show vsan membership** command (see [Example 2-1](#) through [Example 2-3](#)).

### Example 2-1 Displays Membership Information for the Specified VSAN

```
switch # show vsan 1 membership
vsan 1 interfaces:
    fc1/1  fc1/2  fc1/3  fc1/4  fc1/5  fc1/6  fc1/7  fc1/9
    fc1/10 fc1/11 fc1/12 fc1/13 fc1/14 fc1/15 fc1/16 port-channel 99
```



#### Note

Interface information is not displayed if interfaces are not configured on this VSAN.

### Example 2-2 Displays Static Membership Information for All VSANs

```
switch # show vsan membership
vsan 1 interfaces:
    fc2/16 fc2/15 fc2/14 fc2/13 fc2/12 fc2/11 fc2/10 fc2/9
    fc2/8  fc2/7  fc2/6  fc2/5  fc2/4  fc2/3  fc2/2  fc2/1
    fc1/16 fc1/15 fc1/14 fc1/13 fc1/12 fc1/11 fc1/10 fc1/9
    fc1/7  fc1/6  fc1/5  fc1/4  fc1/3  fc1/2  fc1/1
vsan 2 interfaces:
    fc1/8
vsan 7 interfaces:
vsan 100 interfaces:
vsan 4094(isolated vsan) interfaces:
```

### Example 2-3 Displays Static Membership Information for a Specified Interface

```
switch # show vsan membership interface fc1/1
fc1/1
    vsan:1
    allowed list:1-4093
```



## Default VSAN

The factory settings for switches in the Cisco MDS 9000 Family have only the default VSAN 1 enabled. We recommend that you do not use VSAN 1 as your production environment VSAN. If no VSANs are configured, all devices in the fabric are considered part of the default VSAN. By default, all ports are assigned to the default VSAN.



---

**Note** VSAN 1 cannot be deleted, but it can be suspended.

---



---

**Note** Up to 256 VSANs can be configured in a switch. Of these, one is a default VSAN (VSAN 1), and another is an isolated VSAN (VSAN 4094). User-specified VSAN IDs range from 2 to 4093.

---

## Isolated VSAN

VSAN 4094 is an isolated VSAN. All non-trunking ports are transferred to this VSAN when the VSAN to which they belong is deleted. This avoids an implicit transfer of ports to the default VSAN or to another configured VSAN. All ports in the deleted VSAN are isolated (disabled).



---

**Note** When you configure a port in VSAN 4094 or move a port to VSAN 4094, that port is immediately isolated.

---



---

**Caution** Do not use an isolated VSAN to configure ports.

---



---

**Note** Up to 256 VSANs can be configured in a switch. Of these, one is a default VSAN (VSAN 1), and another is an isolated VSAN (VSAN 4094). User-specified VSAN IDs range from 2 to 4093.

---

## Displaying Isolated VSAN Membership

The **show vsan 4094 membership** command displays all ports associated with the isolated VSAN.

## Operational State of a VSAN

A VSAN is in the operational state if the VSAN is active and at least one port is up. This state indicates that traffic can pass through this VSAN. This state cannot be configured.

## Static VSAN Deletion

When an active VSAN is deleted, all of its attributes are removed from the running configuration. VSAN-related information is maintained by the system software as follows:

- VSAN attributes and port membership details are maintained by the VSAN manager. This feature is affected when you delete a VSAN from the configuration. When a VSAN is deleted, all the ports in that VSAN are made inactive and the ports are moved to the isolated VSAN. If the same VSAN is recreated, the ports do not automatically get assigned to that VSAN. You must explicitly reconfigure the port VSAN membership (see Figure 2-4)

Figure 2-4 VSAN Port Membership Details

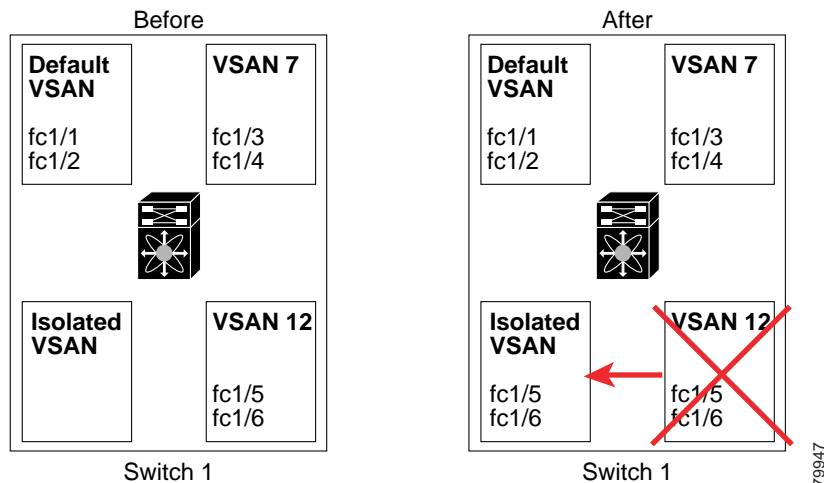

- VSAN-based runtime (name server), zoning, and configuration (static routes) information is removed when the VSAN is deleted.
- Configured VSAN interface information is removed when the VSAN is deleted.

**Note**

The allowed VSAN list is not affected when a VSAN is deleted (refer to the *Cisco MDS 9000 Family NX-OS Interfaces Configuration Guide*).

Any commands for a nonconfigured VSAN are rejected. For example, if VSAN 10 is not configured in the system, then a command request to move a port to VSAN 10 is rejected.

## Deleting Static VSANs

To delete a VSAN and its various attributes, follow these steps:

	Command	Purpose
Step 1	switch# <b>config t</b>	Enters configuration mode.
Step 2	switch(config)# <b>vsan database</b> switch(config-db)#	Configures the VSAN database.
Step 3	switch-config-db# <b>vsan 2</b> switch(config-vsan-db)#	Places you in VSAN configuration mode.
Step 4	switch(config-vsan-db)# <b>no vsan 5</b> switch(config-vsan-db)#	Deletes VSAN 5 from the database and switch.
Step 5	switch(config-vsan-db)# <b>end</b> switch#	Places you in EXEC mode.

## Load Balancing

Load balancing attributes indicate the use of the source-destination ID (src-dst-id) or the originator exchange OX ID (src-dst-ox-id, the default) for load balancing path selection.

## Configuring Load Balancing

To configure load balancing on an existing VSAN, follow these steps:

	Command	Purpose
Step 1	switch# <b>config t</b>	Enters configuration mode.
Step 2	switch(config)# <b>vsan database</b> switch(config-vsan-db)#	Enters VSAN database configuration submode
Step 3	switch(config-vsan-db)# <b>vsan 2</b>	Specifies an existing VSAN.
Step 4	switch(config-vsan-db)# <b>vsan 2</b> <b>loadbalancing src-dst-id</b>	Enables the load balancing guarantee for the selected VSAN and directs the switch to use the source and destination ID for its path selection process.
	switch(config-vsan-db)# <b>no vsan 2</b> <b>loadbalancing src-dst-id</b>	Negates the command issued in the previous step and reverts to the default values of the load balancing parameters.
	switch(config-vsan-db)# <b>vsan 2</b> <b>loadbalancing src-dst-ox-id</b>	Changes the path selection setting to use the source ID, the destination ID, and the OX ID (default).
Step 5	switch(config-vsan-db)# <b>vsan 2 suspend</b>	Suspends the selected VSAN.
Step 6	switch(config-vsan-db)# <b>no vsan 2 suspend</b>	Negates the <b>suspend</b> command issued in the previous step.
Step 7	switch(config-vsan-db)# <b>end</b> switch#	Returns you to EXEC mode.

## Interop Mode

Interoperability enables the products of multiple vendors to come into contact with each other. Fibre Channel standards guide vendors towards common external Fibre Channel interfaces. See the [“Switch Interoperability”](#) section on page 11-9.

## FICON VSANs

You can enable FICON in up to eight VSANs. See the [“FICON VSAN Prerequisites”](#) section on page 10-7.

## Displaying Static VSAN Configuration

Use the **show vsan** command to display information about configured VSANs (see Examples 2-7 to 2-6).

**Example 2-4** *Displays the Configuration for a Specific VSAN*

```
switch# show vsan 100
vsan 100 information
      name:VSAN0100 state:active
      in-order guarantee:no interoperability mode:no
      loadbalancing:src-id/dst-id/oxid
```

**Example 2-5** *Displays the VSAN Usage*

```
switch# show vsan usage
4 vsan configured
configured vsans:1-4
vsans available for configuration:5-4093
```

**Example 2-6** *Displays All VSANs*

```
switch# show vsan
vsan 1 information
      name:VSAN0001 state:active
      in-order guarantee:no interoperability mode:no
      loadbalancing:src-id/dst-id/oxid
vsan 2 information
      name:VSAN0002 state:active
      in-order guarantee:no interoperability mode:no
      loadbalancing:src-id/dst-id/oxid
vsan 7 information
      name:VSAN0007 state:active
      in-order guarantee:no interoperability mode:no
      loadbalancing:src-id/dst-id/oxid
vsan 100 information
      name:VSAN0100 state:active
      in-order guarantee:no interoperability mode:no
      loadbalancing:src-id/dst-id/oxid
vsan 4094:isolated vsan
```

## Default Settings

[Table 2-2](#) lists the default settings for all configured VSANs.

**Table 2-2** *Default VSAN Parameters*

Parameters	Default
Default VSAN	VSAN 1.
State	Active state.
Name	Concatenation of VSAN and a four-digit string representing the VSAN ID. For example, VSAN 3 is VSAN0003.
Load-balancing attribute	OX ID (src-dst-ox-id).

# Displaying Fabric Switch Information

Use the **show fabric switch information vsan** command to display information about each switch in the fabric in the given VSAN.

*Example 2-7 Displays Information about All the Switches in the Fabric*

```
switch# show fabric switch information vsan 100
```

```
VSAN 1:
```

SwitchName	Model	Version	SupMemory
huashan12	DS-C9148-48P-K9	5.2 (2d)	n/a
alishan-bgl-25	DS-C9250I-K9	6.2 (5a)	n/a
Hac18	DS-C9506	6.2 (7)	2 GB
Hac17	DS-C9506	6.2 (5)	n/a
Coco1	DS-C9222I-K9	6.2 (7)	1 GB

```
switch#
```



**Note** This command is not supported prior to Cisco NX-OS Release 6.2(7).



**Note** SUP memory is not displayed for the switches that are running Cisco NX-OS Release prior to 6.2(7).



**Note** Without the VSAN option, this command displays information about switches in all the VSANs.

