



Installing a Cisco Nexus 7010 Chassis

This chapter describes how to install a new or relocated Cisco Nexus 7010 chassis in a rack or cabinet. For information about installing other Cisco Nexus 7000 Series chassis or power supplies, see the following chapters:

This chapter includes the following sections:

- [Preparing to Install the Switch, on page 1](#)
- [Installing the Bottom-Support Rails on the Rack, on page 4](#)
- [Installing the Chassis, on page 7](#)
- [Grounding the Cisco Nexus 7010 Chassis, on page 11](#)
- [Installing Storage Media in a Supervisor Module, on page 16](#)
- [Installing the Front Doors and Frame Assembly, on page 17](#)
- [Installing the Air Filter, on page 24](#)

Preparing to Install the Switch

This section includes the following topics:



Note You must set up one four-post, 19-inch EIA rack or cabinet before you can install the Cisco Nexus 7010 chassis. Make sure that you order the rack or cabinet and have it delivered before installing the chassis.

Required Tools

Before you install the Cisco Nexus 7010 chassis into a rack, make sure that you have the following tools and equipment:

- Mechanical lift capable of lifting 550 pounds (250 kg)
- Number 1 Phillips screwdriver with torque capability
- 3/16-inch flat-blade screwdriver
- Crimping tool
- Wire stripping tool

- Tape measure and level
- Grounding cable



Note These tools and equipment do not ship with the chassis.

Additional tools and equipment, such as an electrostatic discharge (ESD) wrist strap, that you will also need to install the Cisco Nexus 7010 chassis, are included in the Cisco Nexus 7010 accessory kit.



Caution When you handle the Cisco Nexus 7010 chassis or its components, you must follow ESD protocol at all times to prevent ESD damage. This protocol includes but is not limited to wearing an ESD wrist strap that you connect to the earth ground.



Note For a list of tools required to assemble and secure the four-post rack or cabinet, see the documentation that the manufacturer shipped with the rack or cabinet.

Installing a Four-Post Rack or Cabinet

Before you install the Cisco Nexus 7010 chassis, you must install a standard four-post, 19-inch EIA data center rack (or a cabinet that contains such a rack) that meets the requirements listed in the Cisco Nexus 7000 Series Site Preparation Guide. To maximize safety, you should do the following for the rack:

- Bolt the rack to the concrete subfloor before moving the Cisco Nexus 7010 chassis onto it.



Warning Stability hazard. The rack stabilizing mechanism must be in place, or the rack must be bolted to the floor before you slide the unit out for servicing. Failure to stabilize the rack can cause the rack to tip over. Statement 1048

- If the rack has bonded construction, connect it to the earth ground to enable you to easily ground the system components that you install and to ground your ESD wrist strap. This step minimizes the chance of electrostatic discharge when you handle ungrounded components before you install them.

Be sure that the rack includes AC power receptacles with the amperage required for the power supply units that you will be installing in the chassis. If you are installing 6-kW power supply units, you must have 20-A circuits. If you are installing 7.5-kW power supply units, you must have 30-A circuits.



Warning Take care when connecting units to the supply circuit so that wiring is not overloaded. Statement 1018

For instructions on setting up the rack, see the documentation that the manufacturer shipped with the rack.

Unpacking and Inspecting a New Switch

Before you install a new Cisco Nexus 7010 chassis, you need to unpack and inspect it to be sure that you have all the items that you ordered and verify that the switch was not damaged during shipment. If anything is damaged or missing, contact your customer representative immediately.



Tip Do not discard the shipping container when you unpack the Cisco Nexus 7010 system. Flatten the shipping cartons and store them with the pallet used for the system. If you need to move or ship the system in the future, you will need these containers. For repacking instructions, see [Appendix E, “Repacking the Cisco Nexus 7000 Series Switch for Shipment.”](#)

To inspect the shipment, follow these steps:

SUMMARY STEPS

1. Compare the shipment to the equipment list provided by your customer service representative and verify that you have received all of the ordered items. The shipment should include boxes for the following:
2. Check the contents of each box or package for damage.
3. If you notice any discrepancies or damage, send the following information to your customer service representative by e-mail:

DETAILED STEPS

Step 1 Compare the shipment to the equipment list provided by your customer service representative and verify that you have received all of the ordered items. The shipment should include boxes for the following:

- System chassis, which includes the following installed components:
 - 2 supervisor modules
 - 1 to 8 I/O modules
 - 3 to 5 fabric modules
 - 2 system fan trays
 - 2 fabric fan trays
- 2 to 3 power supply units

The power supply units are shipped with the chassis but are boxed separately.

- Cisco Nexus 7010 system accessory kit

To see a list of what is in the accessory kit, see the [Cisco Nexus 7010 System Accessory Kit Contents](#) document, which is included in the kit.

- Mid-chassis doors and frame (optional)
- Air filter (optional)

Step 2 Check the contents of each box or package for damage.

Step 3 If you notice any discrepancies or damage, send the following information to your customer service representative by e-mail:

- Invoice number of the shipper (see the packing slip)
- Model and serial number of the missing or damaged unit
- Description of the problem and how it affects the installation

Installing the Bottom-Support Rails on the Rack

The bottom-support rails hold the Cisco Nexus 7010 chassis on the rack or cabinet. To maximize the stability of the rack, you must attach these rails at the lowest possible rack unit (RU).

The prerequisites, tools, and process for installing the bottom-support rails are included in the following topics:

Prerequisites for Attaching the Bottom-Support Rails

Before you can attach the bottom-support rails, you must fully install the rack or cabinet, and should, for maximum stability, bolt the rack or cabinet to the concrete subfloor. If anything lighter than the Cisco Nexus 7010 system is already installed in the rack, you should make sure that it is positioned above where you will be installing the Cisco Nexus 7010 system. Also, you must have the bottom-support rail kit, which ships with the Cisco Nexus 7010 system accessory kit. The distance between the front and rear mounting brackets on the rack or cabinet must be between 24 and 32 inches (60.96 and 81.28 cm) to fit the bottom-support rails.

Required Tools and Equipment

You need the following tools and equipment to attach the bottom-support rails:

- Number 1 Phillips-head screwdriver with torque capability.
- Rack-mount kit (shipped with the accessory kit). [Table 1: Contents for the Rack-Mount Kit, on page 4](#) lists the items in the rack-mount kit.

Table 1: Contents for the Rack-Mount Kit

Part Description	Quantity
12-24 x 3/4 in. Phillips screws	20
M6 x 19 mm Phillips screws	20
Adjustable bottom-support rails	2

Attaching the Bottom-Support Rails

To maximize the stability of the rack, you should install the chassis as low as possible on the rack. Install the heaviest system first at the bottom of the rack. If you install a second system in the same rack, install it immediately above the lower system if there is enough vertical space.

To prevent bodily injury when mounting or servicing this unit in a rack, you must take special precautions to ensure that the system remains stable. The following guidelines are provided to ensure your safety:

- This unit should be mounted at the bottom of the rack if it is the only unit in the rack.
- When mounting this unit in a partially filled rack, load the rack from the bottom to the top with the heaviest component at the bottom of the rack.
- If the rack is provided with stabilizing devices, install the stabilizers before mounting or servicing the unit in the rack. Statement 1006

To attach the bottom-support rails to a four-post EIA rack, follow these steps:

Step 1

Position one of the two adjustable bottom-support rails at the lowest possible RU. If you are installing a chassis above another Cisco Nexus 7010 chassis, position the rail 36.75 inches (93.4 cm) (21 RU) above the bottom-support rails for the lower chassis as shown in [Figure 1: Positioning the Bottom-Support Rails, on page 6](#). Adjust the length of the rail so that it stretches from the outer edges of the front and rear vertical mounting rails. You can expand the rail so that its mounting brackets are spaced between 24 to 32 inches (60.96 to 81.28 cm).

Figure 1: Positioning the Bottom-Support Rails

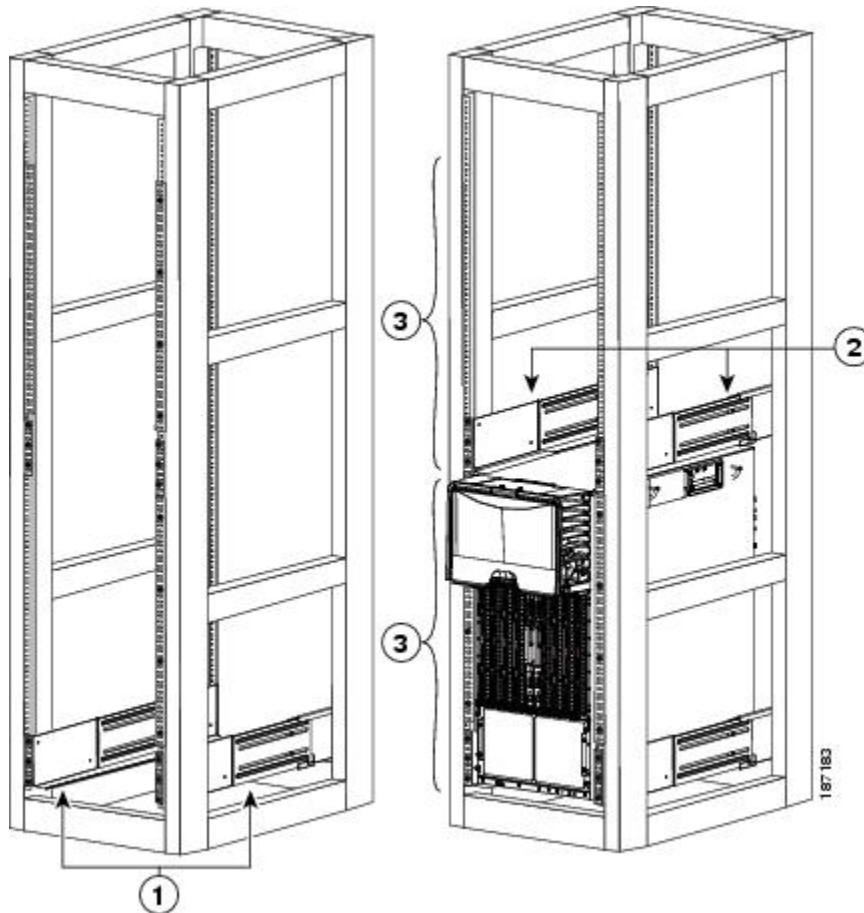

1 For the first and heaviest Cisco Nexus 7010 chassis installed in a rack, position two bottom-support rails at the lowest RU on the rack.	3 Allow at least 36.75 inches (93.4 cm) (21 RU) for each Cisco Nexus 7010 system.
2 For the second Cisco Nexus 7010 chassis installed in a rack, position two bottom-support rails immediately above the first installed switch.	

Step 2

Use a Phillips screwdriver to screw in three M6 x 19 mm or 12-24 x 3/4 in. Phillips screws on each end of each rail (using a total of 12 screws for both brackets) as shown in [Figure 2: Attaching a Bottom-Support Rail to a Rack, on page 7](#).

Note Three of the screw holes on each end of the bottom-support rail align to the screw holes in the mounting rail. Use a screw in each of these screw holes.

Figure 2: Attaching a Bottom-Support Rail to a Rack

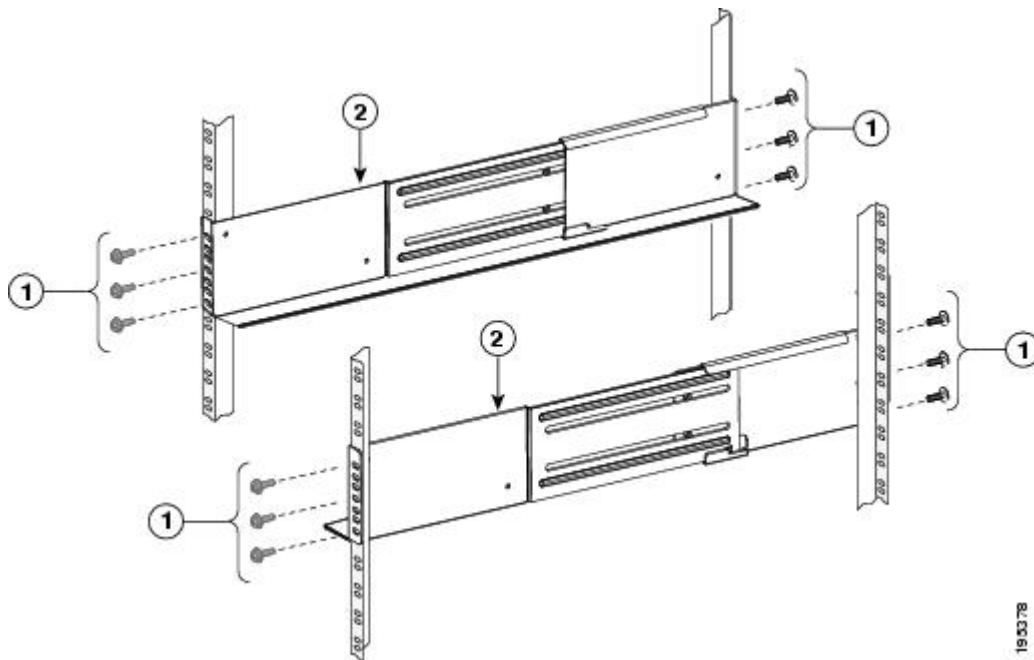

1 Four sets of 3 M6 x 19 mm Phillips screws or four sets of 3 12-24 x 3/4 in. Phillips screws	2 Adjustable bottom-support rails (2)
---	---------------------------------------

Installing the Chassis

This section describes how to install the Cisco Nexus 7010 chassis in a rack or cabinet. These installation steps include transporting the chassis, elevating the chassis to the rack using a mechanical lift, pushing the chassis onto the rack, and then securing the chassis to the rack.

This section includes the following topics:

Prerequisites for Installing the Chassis

Before you install the chassis, you must make sure that the following items are available for the installation:

- Data center ground is accessible where you are installing the Cisco Nexus 7010 chassis.
- Four-post, 19-inch EIA rack or cabinet that includes such a rack.

For more information on the rack or cabinet, see the [Installing a Four-Post Rack or Cabinet](#), on page 2.



Warning Stability hazard. The rack stabilizing mechanism must be in place, or the rack must be bolted to the floor before you slide the unit out for servicing. Failure to stabilize the rack can cause the rack to tip over. Statement 1048

- Bottom-support rails installed in the rack or cabinet—You must already have two bottom-support rails attached to the lowest possible rack unit on the chassis.

For more information, see the [Installing the Bottom-Support Rails on the Rack, on page 4](#).

To prevent bodily injury when mounting or servicing this unit in a rack, you must take special precautions to ensure that the system remains stable. The following guidelines are provided to ensure your safety:

- This unit should be mounted at the bottom of the rack if it is the only unit in the rack.
- When mounting this unit in a partially filled rack, load the rack from the bottom to the top with the heaviest component at the bottom of the rack.
- If the rack is provided with stabilizing devices, install the stabilizers before mounting or servicing the unit in the rack. Statement 1006

- Cisco Nexus 7010 chassis and its components are accounted for and undamaged.

For more information, see the [Unpacking and Inspecting a New Switch, on page 3](#).

Required Tools and Equipment

You need the following tools and equipment to install the Cisco Nexus 7010 chassis:

- Mechanical lift capable of lifting at least 550 pounds (250 kg)



Caution You must use a mechanical lift whenever lifting a device over 120 pounds (55 kg).

- Number 1 Phillips-head screwdriver with torque capability
- Bottom-support rails kit (shipped with the Cisco Nexus 7010 system accessory kit)

Part of this kit has already been used to install the bottom-support rails. [Table 2: Contents for the Rack-Mount Kit, on page 8](#) lists the items in the rack-mount kit.

Table 2: Contents for the Rack-Mount Kit

Part Description	Quantity
12-24 x 3/4 in. Phillips screws	20
M6 x 19 mm Phillips screws	20
Adjustable bottom-support rails	2



Note You should also have at least four persons to push the chassis, which can weigh up to 550 pounds (250 kg), onto and off the mechanical lift and rack.

Installing the Chassis

To install a Cisco Nexus 7010 chassis in a four-post rack or cabinet, follow these steps:

SUMMARY STEPS

1. Load the chassis onto a mechanical lift as follows:
2. Use the mechanical lift to move and align the rear of the chassis to the front of the four-post rack or cabinet. Make sure that the bottom of the chassis is elevated to the height of the bottom-support rails or no more than 1/4 inch (0.635 cm) above the bracket.
3. Use at least four persons to push the chassis onto the installed bottom-support rails as shown in [Figure 3: Moving a Cisco Nexus 7010 Chassis onto a Rack, on page 10](#).
4. Make sure that the screw holes in the chassis mounting brackets align with the screw holes in the vertical mounting rails.
5. Use a Phillips screwdriver to screw in four M6 x 19-mm or 12-24 x 3/4-inch screws in each of the two chassis mounting brackets (use a total of eight screws for two mounting brackets) as shown in [Figure 4: Attaching the Cisco Nexus 7010 Chassis to the Rack, on page 11](#).

DETAILED STEPS

- Step 1** Load the chassis onto a mechanical lift as follows:
- a) Position the mechanical lift next to the shipping pallet that holds the chassis.
 - b) Elevate the lift platform to the level of the bottom of the chassis (or no more than 1/4 inch [0.635 cm] below the bottom of the chassis).
 - c) Use at least four persons to slide the chassis fully onto the lift so that the side of the chassis touches or is close to the vertical rails on the lift. Make sure that the front and rear of the chassis are unobstructed so you can easily push the chassis into the rack.
- Warning** To prevent personal injury or damage to the chassis, never attempt to lift or tilt the chassis using the handles on modules (such as power supplies, fans, or cards); these types of handles are not designed to support the weight of the unit. Statement 1032
- Caution** To lift the chassis, use a mechanical lift, not the handles on the side of the chassis (the handles are not rated for lifting over 200 pounds [91 kg]). Use the side handles for only repositioning the chassis after it is already on the mechanical lift or in the rack or cabinet.
- Step 2** Use the mechanical lift to move and align the rear of the chassis to the front of the four-post rack or cabinet. Make sure that the bottom of the chassis is elevated to the height of the bottom-support rails or no more than 1/4 inch (0.635 cm) above the bracket.
- Step 3** Use at least four persons to push the chassis onto the installed bottom-support rails as shown in [Figure 3: Moving a Cisco Nexus 7010 Chassis onto a Rack, on page 10](#).

Push the lower half of the front side of the chassis so that the back side enters the rack first, and push until the chassis mounting brackets come in contact with the front vertical mounting rails on the rack.

Figure 3: Moving a Cisco Nexus 7010 Chassis onto a Rack

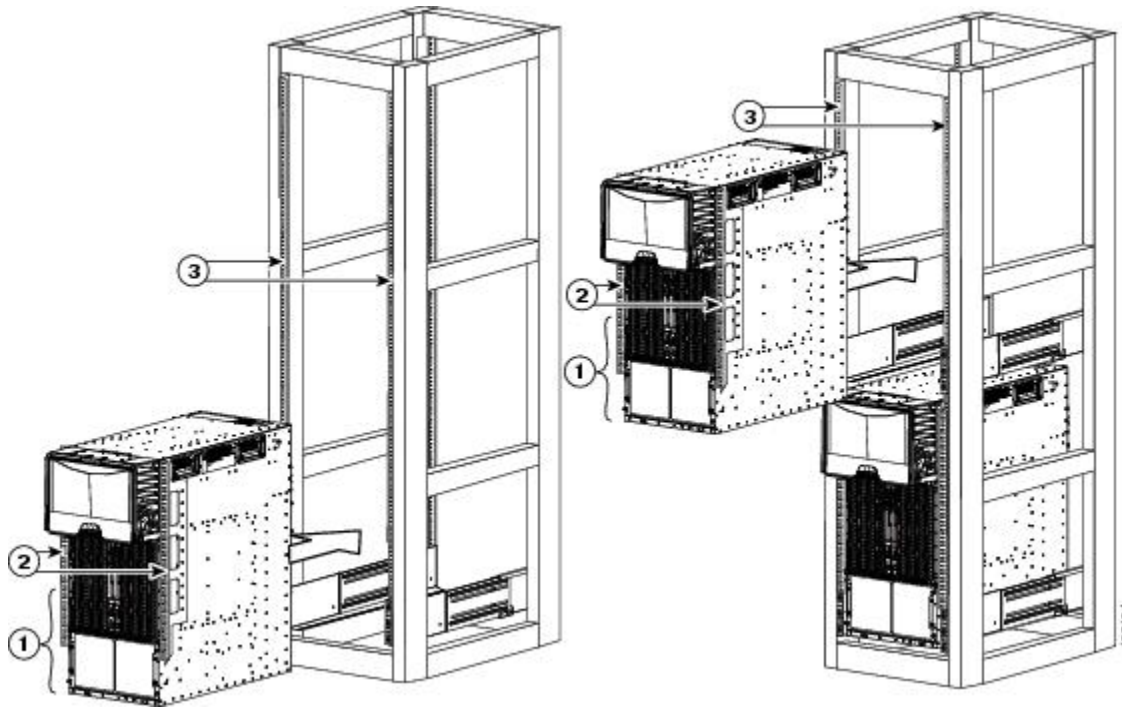

1	Push the lower half of the front side of the chassis	3	Rack vertical mounting rails
2	Chassis mounting brackets		

Step 4 Make sure that the screw holes in the chassis mounting brackets align with the screw holes in the vertical mounting rails. If you need to reposition the chassis to align the screw holes, you can use the handles on the sides of the chassis.

Tip To adjust the placement of the chassis so that the screw holes in the chassis mounting brackets align with the screw holes in the vertical mounting rails, use the chassis handles shown in [Figure 4: Attaching the Cisco Nexus 7010 Chassis to the Rack, on page 11](#).

Step 5 Use a Phillips screwdriver to screw in four M6 x 19-mm or 12-24 x 3/4-inch screws in each of the two chassis mounting brackets (use a total of eight screws for two mounting brackets) as shown in [Figure 4: Attaching the Cisco Nexus 7010 Chassis to the Rack, on page 11](#).

Figure 4: Attaching the Cisco Nexus 7010 Chassis to the Rack

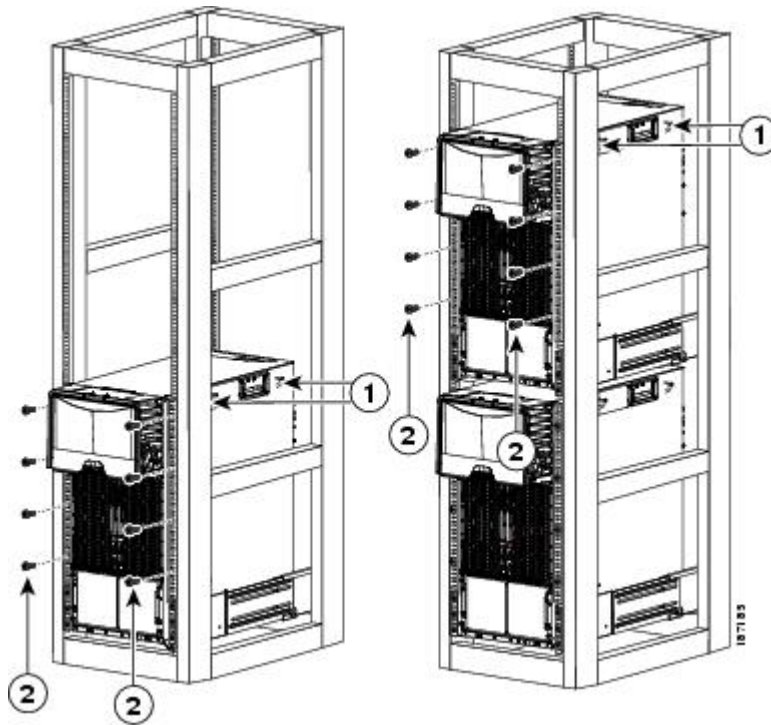

1 Handles used to adjust the chassis placement	2 Four M6 x 19 mm or 10-24 x 3/4 in. Phillips screws used to attach each side bracket to a front mounting rail (use a total of eight screws)
--	--

Grounding the Cisco Nexus 7010 Chassis

The Cisco Nexus 7010 system is grounded through the AC power supply cables and one of two grounding connections on the chassis. The AC power supply cables provide a connection to an earth ground whenever you connect the AC power to the system. The system ground, also referred to as the network equipment building system (NEBS) ground, provides additional grounding for EMI shielding requirements and for the low-voltage supplies (DC-DC converters) on the modules. This grounding system is active even when the AC power cables are not connected to the system. You establish this ground by connecting one of the two grounding pads on the chassis to the rack (if it is connected to an earth ground) or directly to the earth ground for the data center building.

This section includes the following topics:

Prerequisites for Grounding the Chassis

Before you can ground the chassis, you must have a connection to the earth ground for the data center building. If you installed the Cisco Nexus 7010 chassis into a bonded rack (see the rack manufacturer's instructions for more information) that now has a connection to the data center earth ground, you can ground the chassis by

connecting its grounding ports to the rack. Otherwise, you must connect the chassis grounding ports directly to the data center ground.

Required Tools and Equipment

To connect the system ground, you need the following tools and materials:

- Grounding lug—A two-holed standard barrel lug that supports up to 6 AWG wire. This lug is supplied with the Cisco Nexus 7010 system accessory kit.
- Grounding screws—Two M4 x 8 mm (metric) pan-head screws. These screws are shipped with the Cisco Nexus 7010 accessory kit.
- Grounding wire—Not supplied with the Cisco Nexus 7010 system accessory kit. This wire should be sized to meet local and national installation requirements. Depending on the power supply and system, a 12 AWG to 6 AWG copper conductor is required for U.S. installations. We recommend that you use commercially available 6 AWG wire. The length of the grounding wire depends on the proximity of the switch to proper grounding facilities.
- Number 1 Phillips-head screwdriver with torque capability.
- Crimping tool to crimp the grounding wire to the grounding lug.
- Wire-stripping tool to remove the insulation from the grounding wire.

Connecting the System Ground

After you have moved the chassis into the rack or cabinet, you are ready to connect the system to the data center earth ground. After you ground the chassis, you can ground your ESD wrist strap by connecting it to the chassis.

To connect the system ground to the data center earth ground, follow these steps:

-
- Step 1** Use a wire-stripping tool to remove approximately 0.75 inch (19 mm) of the covering from the end of the grounding wire.
- Step 2** Insert the stripped end of the grounding wire into the open end of the grounding lug as shown in [Figure 5: Inserting the Grounding Wire in the Grounding Lug, on page 12](#).

Figure 5: Inserting the Grounding Wire in the Grounding Lug

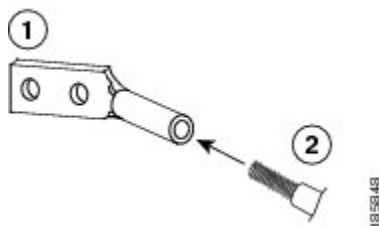

1	NRTL listed 45-degree grounding lug	2	Grounding cable with 0.75 in. (19 mm) of insulation stripped from the end
---	-------------------------------------	---	---

- Step 3** Use the crimping tool to crimp the lug to the grounding wire. Verify that the ground wire is securely attached to the ground lug by attempting to pull the wire out of the crimped lug.

- Step 4** Remove the adhesive label from one of the two system grounding pads, and secure the grounding wire lug to the grounding pad with two M4 screws. [Figure 6: Grounding Pad on the Front of the Cisco Nexus 7010 Chassis, on page 13](#) shows the location of the grounding pads on the front side of the chassis. [Figure 7: Grounding Pad on the Rear of the Cisco Nexus 7010 Chassis, on page 14](#) shows the location on the rear of the chassis. Ensure that the grounding lug and the grounding wire do not interfere with other switch hardware or rack equipment.

Figure 6: Grounding Pad on the Front of the Cisco Nexus 7010 Chassis

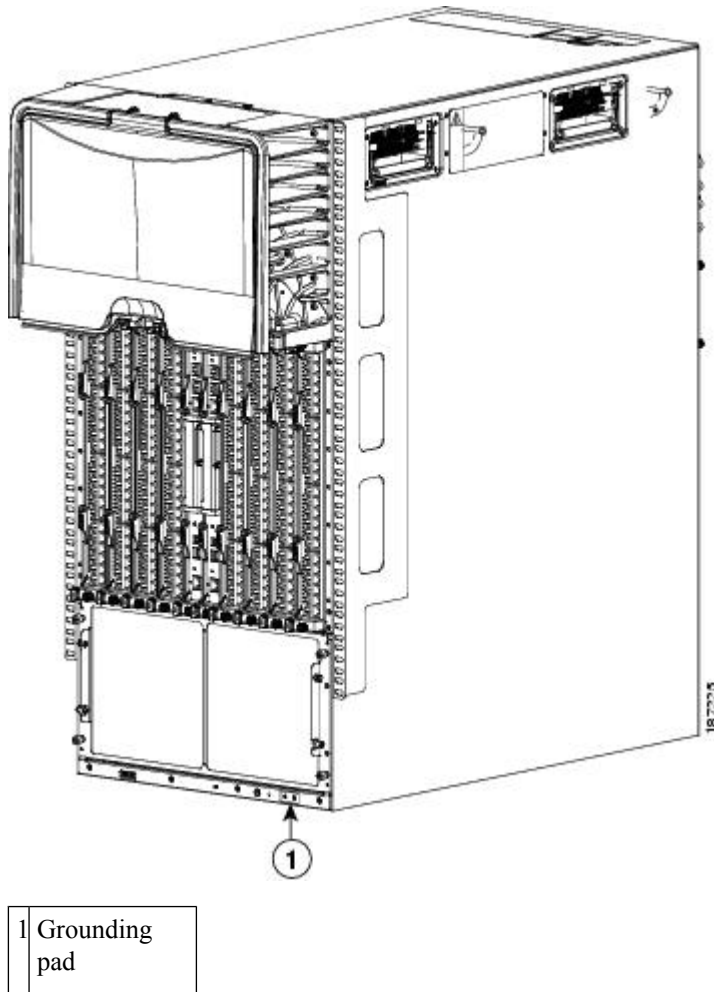
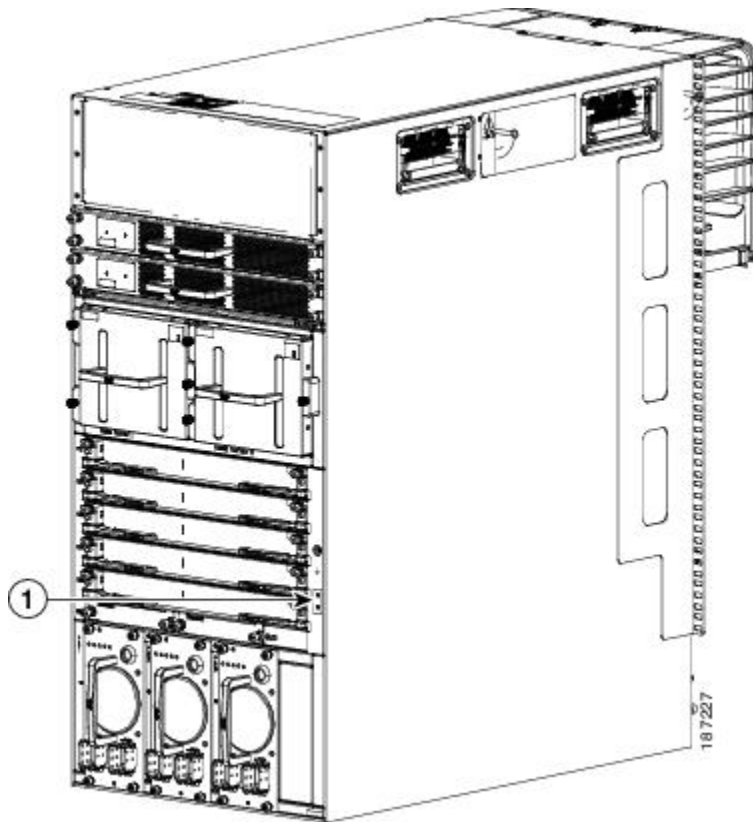

Figure 7: Grounding Pad on the Rear of the Cisco Nexus 7010 Chassis



1	Grounding pad
---	---------------

- Step 5** Prepare the other end of the grounding wire and connect it to an appropriate grounding point in your site to ensure an adequate earth ground for the switch. If the rack is grounded, connect the grounding wire as explained in the documentation provided by the vendor for the rack.

Connecting Your ESD Wrist Strap to the Chassis

After you connect the chassis to the data center earth ground, you can ground your ESD wrist strap by plugging it into any one of three ESD ports shown in [Figure 8: ESD Grounding Ports on the Front of the Cisco Nexus 7010 Chassis, on page 15](#) (front of the chassis) or [Figure 9: ESD Grounding Port on the Rear of the Cisco Nexus 7010 Chassis, on page 16](#) (rear of the chassis).

Figure 8: ESD Grounding Ports on the Front of the Cisco Nexus 7010 Chassis

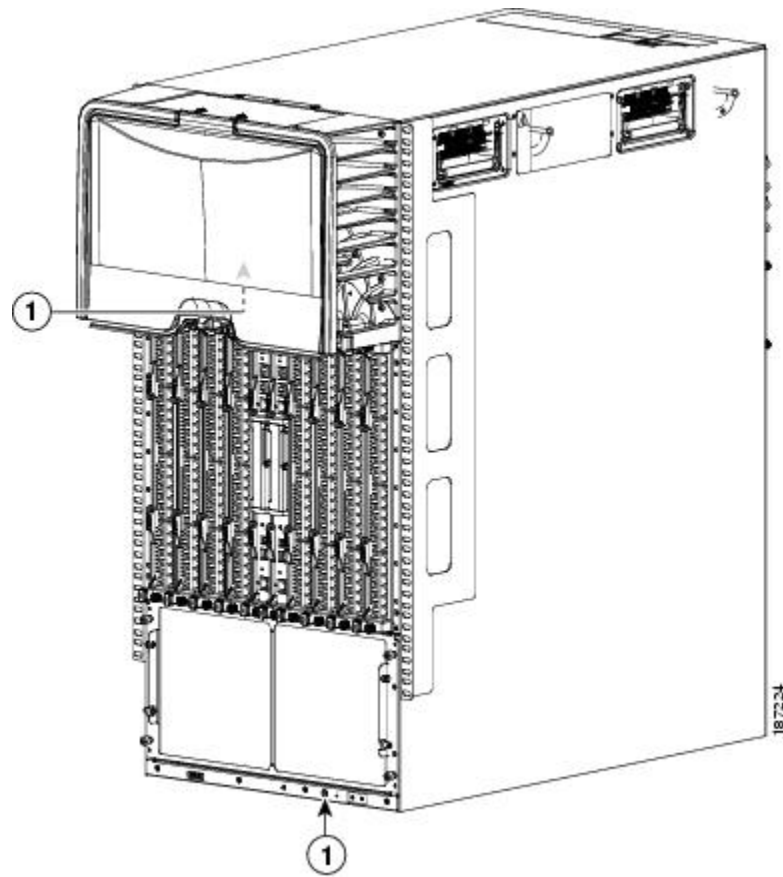

1 ESD grounding port

Figure 9: ESD Grounding Port on the Rear of the Cisco Nexus 7010 Chassis

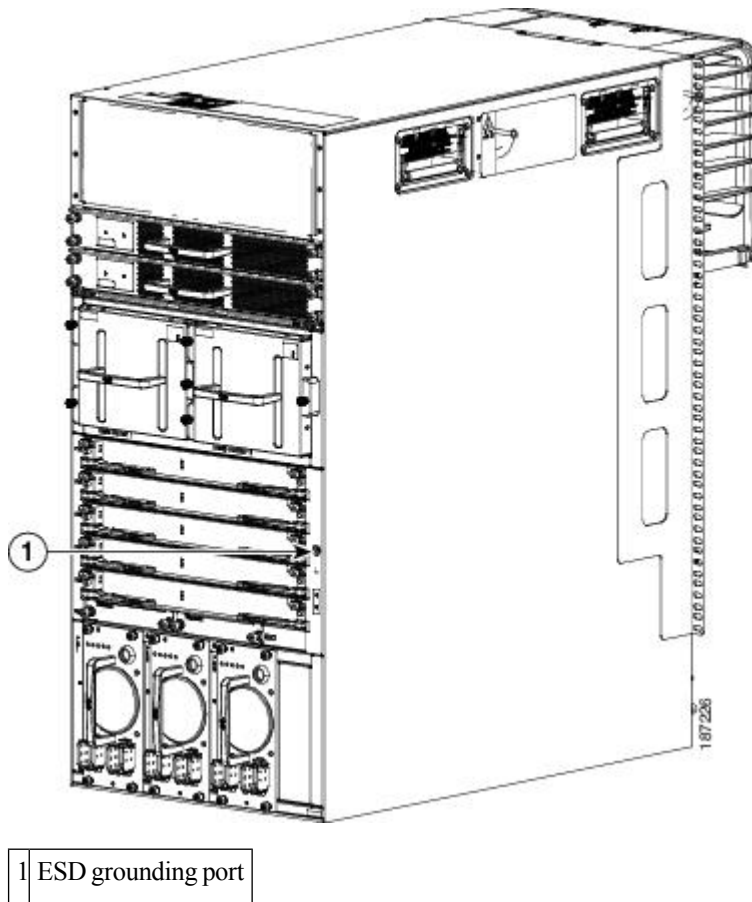

1 ESD grounding port

Installing Storage Media in a Supervisor Module

Each supervisor module on a Cisco Nexus 7000 Series switch is shipped with a CompactFlash card installed in the LOG FLASH reader (Supervisor 1 modules) or a USB drive installed in the LOG FLASH reader (Supervisor 2 and Supervisor 2E modules). The EXPANSION FLASH reader (Supervisor 1) or Slot0 port (Supervisor 2 and 2E) is left empty, but you can optionally install a card in that reader or a USB drive in the USB port. To allow this storage media to function with the reader or port, you must make sure that it is either formatted for the reader before installing it or format it after installing it.



Note The LOG FLASH and EXPANSION FLASH or Slot0 readers require different formats for their storage media.

To replace an installed CompactFlash card, see the [“Replacing Storage Media for a Supervisor Module” section on page 10-61](#).

To install storage media in a supervisor module, follow these steps:

SUMMARY STEPS

1. Align the storage media to its slot or port on the supervisor module as follows:
2. Wait for the reader or port LED to turn green and for a message to appear on the console as follows:

DETAILED STEPS

Step 1 Align the storage media to its slot or port on the supervisor module as follows:

- For a Supervisor 1 module, align the card with the slot for the CompactFlash reader slot labeled LOG FLASH or EXPANSION FLASH as shown in [Figure 10: Aligning a CompactFlash Card to its Reader, on page 17](#). The grooves on the thin side of the card are on the end of the card that goes into the reader first. If the card does not fit easily into the reader, flip the card so that the bottom edge is on top, and try pushing the card into the reader.

Figure 10: Aligning a CompactFlash Card to its Reader

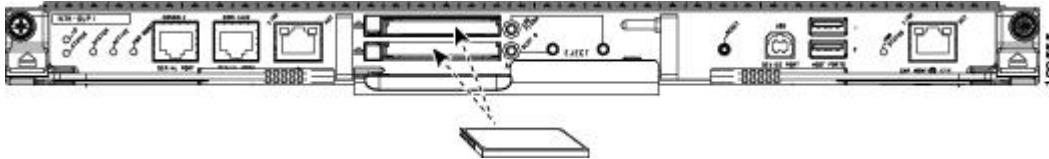

- For a Supervisor 2 or 2E module, insert the USB drive in the LOG FLASH or SLOT0 port.

Step 2 Wait for the reader or port LED to turn green and for a message to appear on the console as follows:

- If you are installing a card or USB drive into the log flash reader, the message will end with “logflash:online.”
- If you are installing a card or USB drive into the expansion flash reader, the message will end with “slot0:online.”
- If you see an “offline” message or do not see a message, either the card or USB drive is not fully inserted or it is improperly formatted.

Make sure that the card or USB drive is fully inserted inside the reader. If it is fully inserted, either format the card (see the *Cisco Nexus 7000 Series NX-OS Fundamentals Configuration Guide*) or replace the storage media with another that is properly formatted for the reader.

Installing the Front Doors and Frame Assembly

After you have finished moving the chassis to its rack, you can install its optional front doors and frame assemblies.

To install the front doors and frame assemblies, follow these steps:

SUMMARY STEPS

1. Align the bottom frame assembly so that its four screw holes align to screw holes in the bottom of the chassis, and then screw in four M4 x 6 mm screws to attach the bottom frame to the chassis (see [Figure 11: Installing the Bottom Frame, on page 19](#)).

2. For each of the two front doors, match the two alignment pins on the door frame to the alignment holes on the chassis. Position each door frame immediately under the cable management area (see [Figure 12: Installing the Front Doors, on page 20](#)).
3. Tighten three screws for each door frame (see [Figure 13: Attaching the Door Frames to the Chassis, on page 21](#)).

DETAILED STEPS

- Step 1** Align the bottom frame assembly so that its four screw holes align to screw holes in the bottom of the chassis, and then screw in four M4 x 6 mm screws to attach the bottom frame to the chassis (see [Figure 11: Installing the Bottom Frame, on page 19](#)).

Figure 11: Installing the Bottom Frame

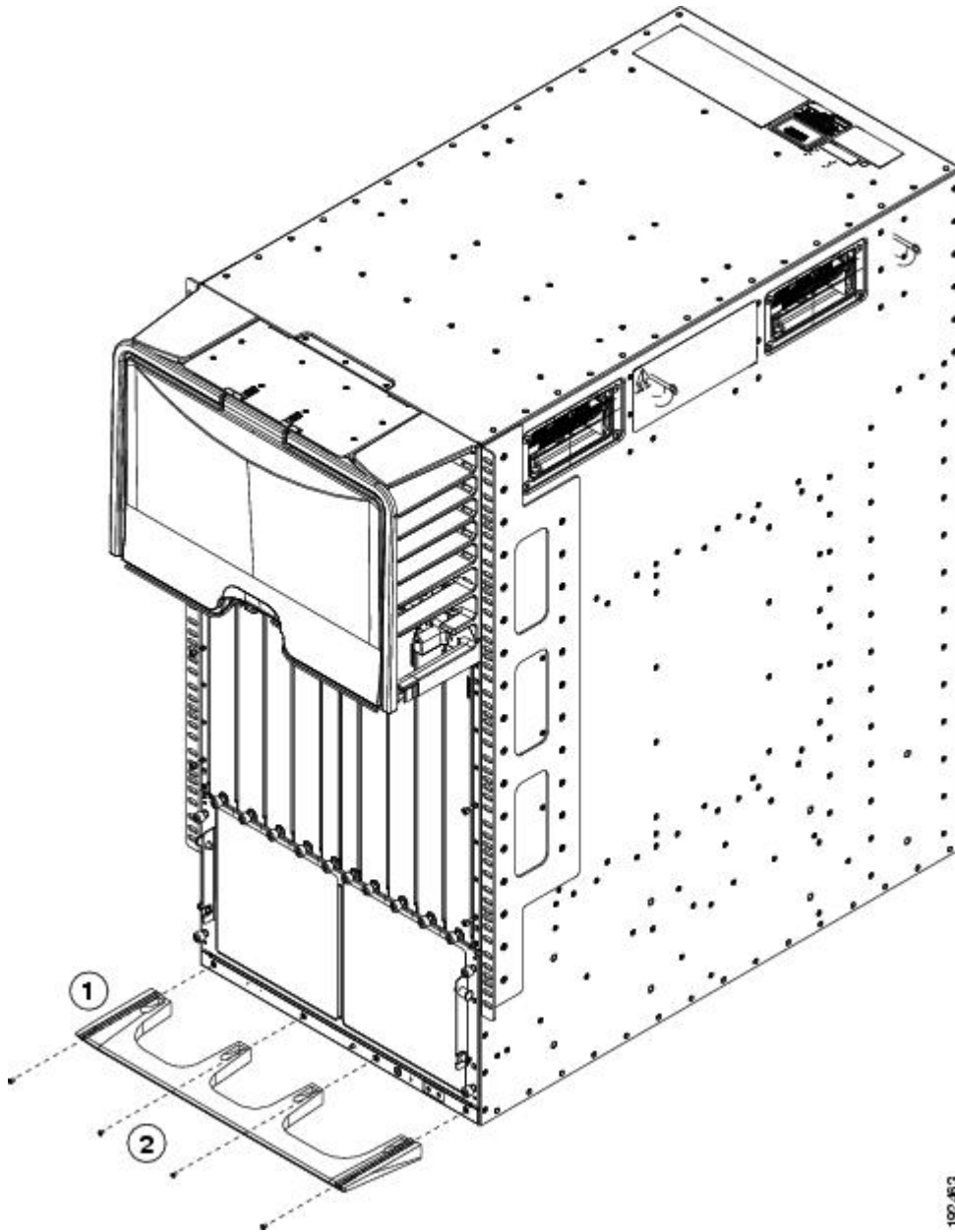

- | | |
|--|-------------------------|
| 1 Bottom frame assembly with screw holes aligned to screw holes in chassis | 2 Four M4 x 6 mm screws |
|--|-------------------------|

Step 2

For each of the two front doors, match the two alignment pins on the door frame to the alignment holes on the chassis. Position each door frame immediately under the cable management area (see [Figure 12: Installing the Front Doors, on page 20](#)).

Figure 12: Installing the Front Doors

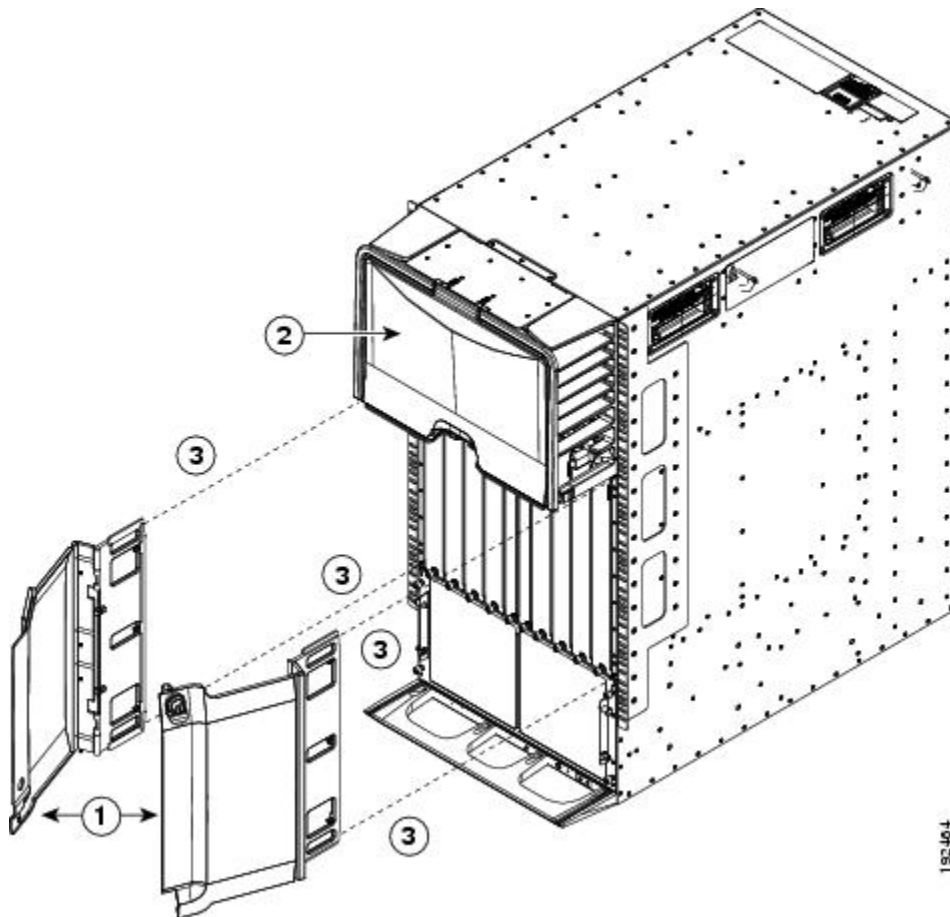

1 Front door frames.	3 Place door frame on front edge of chassis and immediately under the cable management area.
2 Cable management area.	

Step 3 Tighten three screws for each door frame (see [Figure 13: Attaching the Door Frames to the Chassis, on page 21](#)).

Figure 13: Attaching the Door Frames to the Chassis

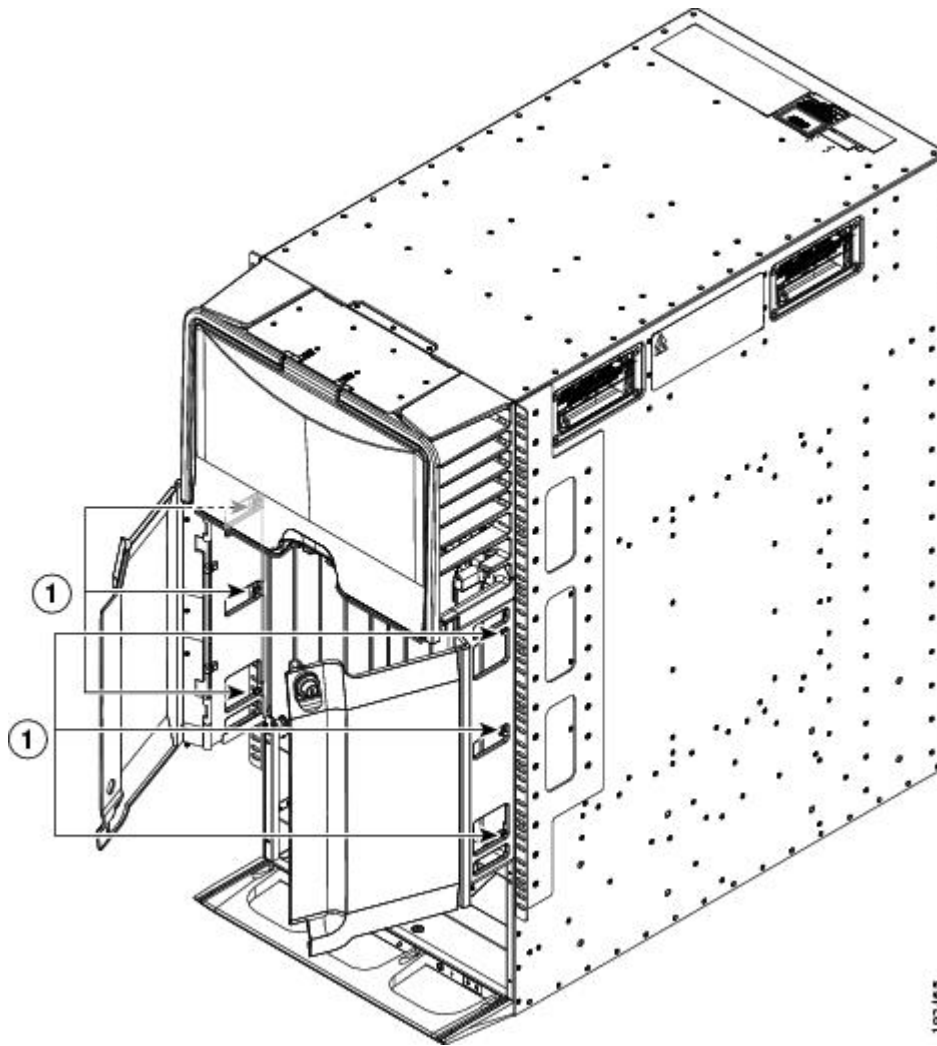

1 For each of two door frames, tighten three captive screws to secure the frame to the chassis.

- a) Remove the EMI panel by unscrewing its four captive screws until each is free of the chassis (see [Figure 14: Removing the EMI Panel](#), on page 22).

Figure 14: Removing the EMI Panel

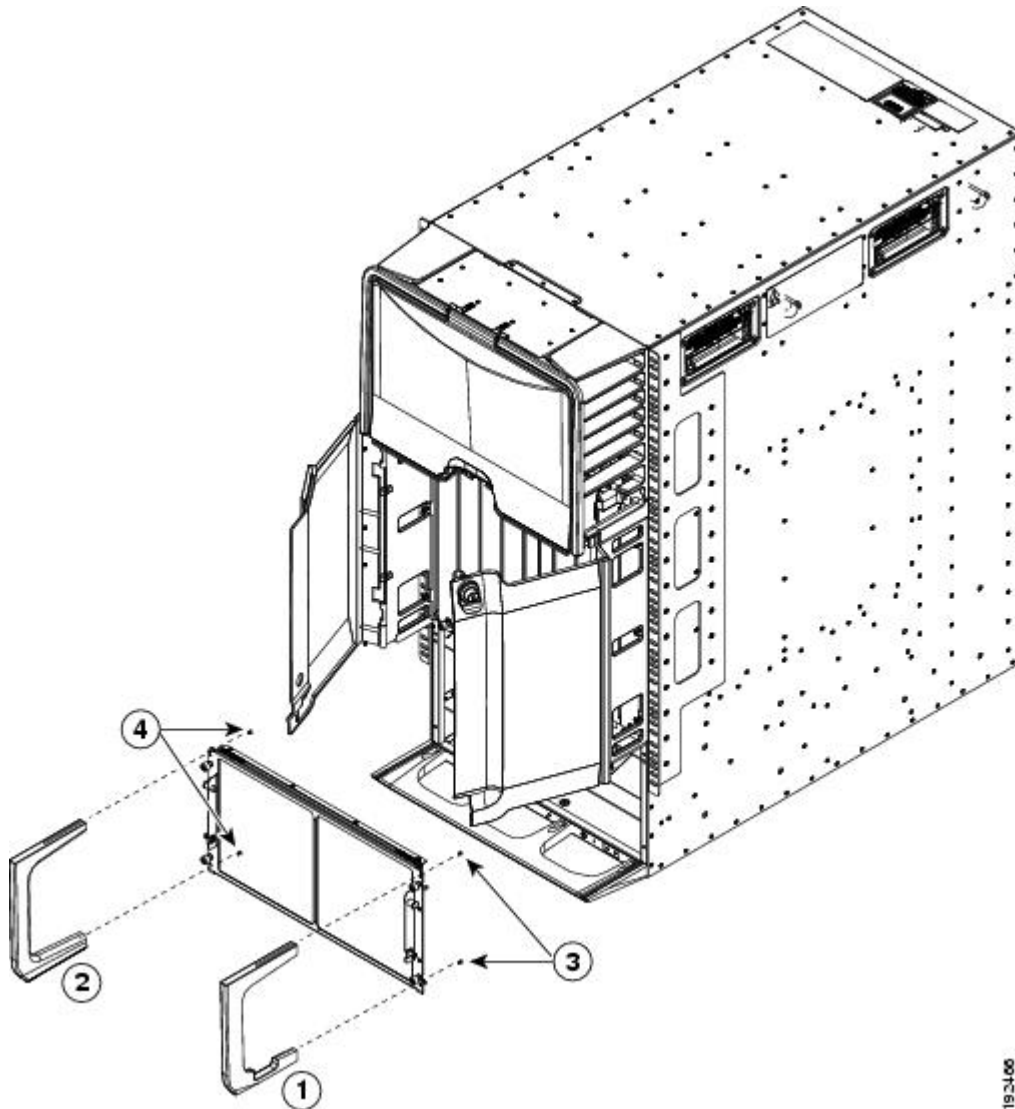

- | | |
|---|--|
| 1 Unscrew four captive screws until they are each clear of the chassis. | 2 Remove the EMI panel from the chassis. |
|---|--|

- b) On each side of the EMI panel, align a side frame piece so that its two screw holes align to two screw holes on one side of the EMI panel. Screw in a screw in each of these two screw holes so that the side frame assembly is attached to the EMI panel. Repeat this step for the other side of the EMI panel. See [Figure 15: Attaching the Side Frame Assemblies to the EMI Panel](#), on page 23.

Figure 15: Attaching the Side Frame Assemblies to the EMI Panel

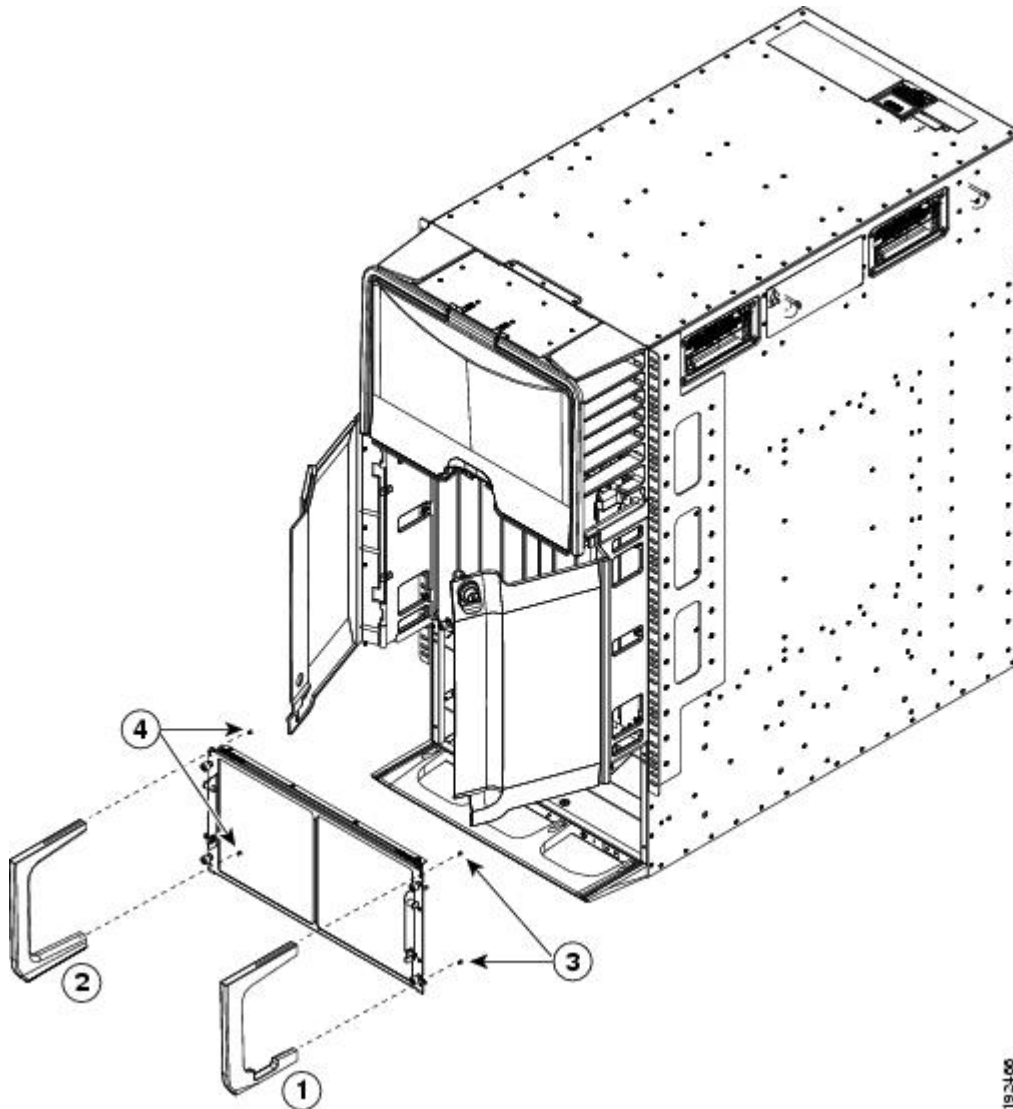

1 Right side frame.	3 Use two 6-32 x 1/2-inch flat-head screws to attach the right side frame to the right side of the EMI panel. Tighten the screws to 8 in-lb (0.9 N·m).
2 Left side frame.	4 Use two 6-32 x 1/2-inch flat-head screws to attach the left side frame to the left side of the EMI panel. Tighten the screws to 8 in-lb (0.9 N·m).

- c) Realign the EMI panel to the air intake area on the chassis, screw its four captive screws to the chassis, and tighten the captive screws to 8 in-lb (0.9 N·m).

Installing the Air Filter

You can install the optional air filter while the Cisco Nexus 7000 Series system is operational.



Note Only the Cisco Nexus 7010 switch includes an optional air filter.

To install an air filter, follow these steps:

SUMMARY STEPS

1. Align the air filter to the EMI panel, which covers the air intake area.
2. Use one hand on the air filter to hold it in place while you use the other hand to pull out the spring pin on one side of the air filter. Adjust the air filter so that the spring pin will be released into its hole in the EMI panel bracket.
3. Switch hands to hold the air filter on the EMI panel and use the free hand to pull out the other spring pin on the other side of the air filter. With the spring pin pulled out, position the air filter so that the pin will be released into its hole on the EMI panel bracket. Release the spring pin and make sure that it holds the air filter on to the EMI panel.
4. Screw in and tighten both captive screws, one on each side of the air filter.

DETAILED STEPS

-
- | | |
|---------------|--|
| Step 1 | Align the air filter to the EMI panel, which covers the air intake area. |
| Step 2 | Use one hand on the air filter to hold it in place while you use the other hand to pull out the spring pin on one side of the air filter. Adjust the air filter so that the spring pin will be released into its hole in the EMI panel bracket. |
| Step 3 | Switch hands to hold the air filter on the EMI panel and use the free hand to pull out the other spring pin on the other side of the air filter. With the spring pin pulled out, position the air filter so that the pin will be released into its hole on the EMI panel bracket. Release the spring pin and make sure that it holds the air filter on to the EMI panel. |
| Step 4 | Screw in and tighten both captive screws, one on each side of the air filter. |
-