



# Cisco ACI Simulator Release Notes, Release 3.0(1)

This document provides the compatibility information, usage guidelines, and the scale values that were validated in testing this Cisco ACI Simulator release. Use this document in combination with the documents listed in the *Related Documentation* section.

Note: The Cisco ACI Simulator 3.0(1k) release contains the same functionality as the Cisco APIC 3.0(1k) release. For information about the functionality, see the *Cisco Application Policy Infrastructure Controller, 3.0(1k), Release Notes*, which you can view at the following location:

<https://www.cisco.com/c/en/us/support/cloud-systems-management/application-policy-infrastructure-controller-apic/tsd-products-support-series-home.html>

Note: The documentation set for this product strives to use bias-free language. For the purposes of this documentation set, bias-free is defined as language that does not imply discrimination based on age, disability, gender, racial identity, ethnic identity, sexual orientation, socioeconomic status, and intersectionality. Exceptions may be present in the documentation due to language that is hardcoded in the user interfaces of the product software, language used based on RFP documentation, or language that is used by a referenced third-party product.

Table 1 shows the online change history for this document.

Table 1. Online History Change

Date	Description
August 10, 2017	Created the release notes for the 3.0(1k) release.

## Contents

This document includes the following sections:

- [Introduction](#)
- [Software Features](#)
- [Installation Notes](#)
- [Compatibility Information](#)
- [Usage Guidelines](#)
- [Supported Scale with the ACI Simulator](#)

## Related Documentation Installation Notes

### Installation Notes

- 

### Introduction

The Application Centric Infrastructure (ACI) is conceptualized as a distributed, scalable, multi-tenant infrastructure with external endpoint connectivity that is controlled and grouped through application centric policies. The Application Policy Infrastructure Controller (APIC) is the key architectural component that is the unified point of automation, management, monitoring, and programmability for the Application Centric Infrastructure. The APIC supports the deployment, management and monitoring of any application anywhere, with a unified operations model for physical and virtual components of the infrastructure. The APIC programmatically automates network provisioning and control based on the application requirements and policies. It is the central control engine for the broader cloud network, simplifying management while allowing tremendous flexibility in how application networks are defined and automated and also providing northbound REST APIs. The APIC is a distributed system implemented as a cluster of many controller instances.

### ACI Simulator

The intent of the ACI Simulator is to provide real, fully-featured APIC software, along with a simulated fabric infrastructure of leaf switches and spine switches in one physical server. You can use the ACI Simulator to understand features, exercise APIs, and initiate integration with third-party orchestration systems and applications. The native GUI and CLI of the APIC use the same APIs that are published to third parties.

The ACI Simulator includes simulated switches, so you cannot validate a data path. However, some of the simulated switch ports have been mapped to the front-panel server ports, which allows you to connect external management entities such as ESX servers, vCenters, vShields, bare metal servers, Layer 4 to Layer 7 services, AAA systems, and other physical or virtual service appliances. In addition, the ACI Simulator allows simulation of faults and alerts to facilitate testing and demonstrate features.

One instance of the production APIC will be shipped per server appliance. By contrast, the ACI Simulator includes three actual APIC instances and two simulated leaf switches and two simulated spine switches in a single server. As a result, the performance of the ACI Simulator will be slower than deployments on actual hardware. You can perform operations on the simulated fabric using any of the following functional interfaces:

- Graphical user interface (GUI)
- Command Line Interface (CLI)
- Application programming interface (API)

Figure 1 shows the components and connections simulated within the simulator server.

Figure 1 Simulated Components and Connections in the ACI Simulator Server

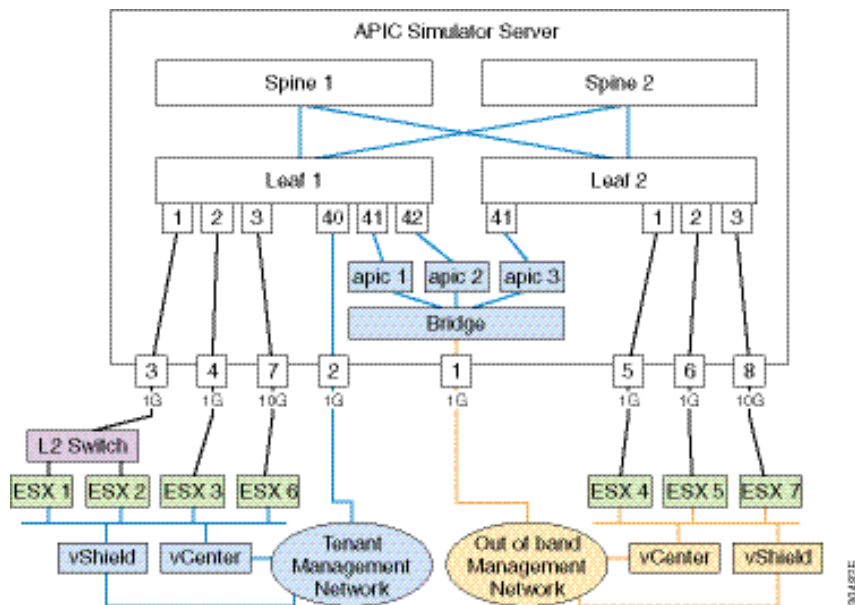

## Software Features

This section lists the key software features of the ACI Simulator that are available in this release.

- Application centric network policies
- Data model-based declarative provisioning
- Application, topology monitoring, and troubleshooting
- Third-party integration (Layer 4 to Layer 7 services, WAN, vCenter, vShield)
- Physical infrastructure policies (spine and leaf)
- ACI inventory and configuration
- Implementation on a distributed framework across a cluster of appliances
- Health Scores for key Managed Objects (tenants, application profiles, switches, and so on)
- Fault, event and performance management

## Installation Notes

The Cisco ACI Simulator is preinstalled on the ACI Simulator appliance. When you launch the ACI Simulator for the first time, the APIC console presents a series of initial setup options. See the *Cisco ACI Simulator Installation Guide* for information about the setup options.

## Compatibility Information

This release of the ACI Simulator supports the following software:

- VMware vCenter 5.1 and 5.5 and vShield 5.1 and 5.5
- Web browsers for the ACI Simulator GUI:
  - Chrome version 35 (at minimum) on Mac and Windows
  - Firefox version 26 (at minimum) on Mac and Windows

## Usage Guidelines

This section includes usage guidelines that are specific to this release.

- [General Usage Guidelines](#)
- [Layer 4 to Layer 7 Services Usage Guidelines](#)

## General Usage Guidelines

Observe the following guidelines when using this software release:

- The ACI Simulator software cannot be installed separately on a standard Cisco UCS C220 Server or on other servers. The software runs only on the ACI Simulator server, which has the following PID:
  - APIC-SIM-S2 (based on Cisco UCS C220 M4 server)
- The ACI Simulator GUI includes an online version of the Quick Start guide that includes video demonstrations.
- Do not do change the following:
  - Default names in the initial setup for node names and the cluster configuration.
  - Cluster size and the number of APIC nodes.
  - Infra VLAN.
- The ACI Simulator does not support the following:
  - Configuration of a DHCP server policy.
  - Configuration of a DNS service policy.
  - Configuring out-of-band management access for switches.
  - Data path forwarding (the ACI Simulator includes simulated switches).
  - CDP is not supported between a leaf and an ESX/hypervisor or between a leaf and an unmanaged/L2 switch. Only LLDP is supported in these cases.
- The ACI Simulator uses NAT for inband management. Inband IPs configured by policy are not used. Instead, APIC and node inband IPs are internally allocated.

## Usage Guidelines

- APIC out-of-band management IP/Gateway cannot be modified using an out-of-band management policy and can be configured only during the APIC first time setup screen.
- Keep the vMotion PNIC outside of the Simulator network.
- The infrastructure EPG in the Infra tenant is for internal use only.
- The MP-BGP route reflector and the OSPF external routed network protocols do not work if you are using the simulator
- Virtual shell (VSH) and ishell commands do not work on switches. These commands are implemented on the Cisco NX-OS software, and the Cisco NX-OS software is not available on the simulator.
- The MP-BGP route reflector and the OSPF external routed network protocols do not work if you are using the simulator.
- Virtual shell (VSH) and ishell commands do not work on switches. These commands are implemented on the Cisco NX-OS software, and the Cisco NX-OS software is not available on the simulator.
- Statistics are simulated. As a result, threshold crossing alert (TCA) faults are generated in the simulator to demonstrate the fault generation on the statistics threshold crossing.
- Create a syslog and Call Home source policy under common policy. This policy applies at the system level and sends all syslog and Call Home messages system wide. The GUI path to create syslog and Call Home under common policy are as follows: Admin / External Data Collector/ Monitoring Destinations / [Callhome | SNMP | Syslog].
- The Cisco ACI Simulator simulates faults for counters, which might cause the health score of the top-of-rack (TOR) switch to go down. The faults look similar to the following:

```
<faultInst ack="no" cause="threshold-crossed" changeSet="" childAction="" code="F54431" created="2014-01-21T17:20:13.179+00:00" descr="TCA: I2IngrBytes5min dropRate value 9049.94 raised above threshold 9000 and value is recovering " dn="topology/pod-1/node-17/sys/ctx-[vxlan-2621440]/bd-[vxlan-15826914]/vlan-[vlan-1031]/fault-F54431" domain="infra" highestSeverity="minor" lastTransition="2014-01-21T17:22:35.185+00:00" lc="raised" modTs="never" occur="1" origSeverity="minor" prevSeverity="minor" rule="tca-l2-ingr-bytes-drop-rate" severity="minor" status="" subject="counter" type="operational" /> <faultInst ack="no" cause="threshold-crossed" changeSet="" childAction="" code="F54447" created="2014-01-21T17:20:13.244+00:00" descr="TCA: I2IngrPkts5min dropRate value 3.53333 raised above threshold 10" dn="topology/pod-1/node-17/sys/ctx-[vxlan-2621440]/bd-[vxlan-15826914]/vlan-[vlan-1031]/fault-F54447" domain="infra" highestSeverity="warning" lastTransition="2014-01-21T19:42:37.983+00:00" lc="retaining" modTs="never" occur="9" origSeverity="warning" prevSeverity="warning" rule="tca-l2-ingr-pkts-drop-rate" severity="cleared" status="" subject="counter" type="operational" />
```

## Layer 4 to Layer 7 Services Usage Guidelines

Observe the following guidelines when using Layer 4 to Layer 7 services:

- This release supports Layer 4 to Layer 7 services integration with Citrix and ASA. These packages are not prepackaged in the Simulator appliance. Depending on the Layer 4 to Layer 7 services that you want to test, you should procure the corresponding package from the file share.
- Service nodes should be connected using the out-of-band connection. The service node and the APIC should be in the same subnet. For information on connecting Layer 4 to Layer 7 services to the Simulator, see the *Cisco Application Centric Infrastructure Simulator Installation Guide*.

## Supported Scale with the ACI Simulator

- You can test Layer 4 to Layer 7 services by connecting your service appliance using in-band management connectivity between the simulator and the appliance.
- For additional information on Layer 4 to Layer 7 services, see the *Cisco APIC Layer 4 to Layer 7 Services Deployment Guide*.

## Supported Scale with the ACI Simulator

Table 2 lists the scale values that were validated in testing this release.

Table 2. Values Tested Without an External Service Node

Object	Value
Tenants	10
EPGs	100
Contracts	100
EPG per Tenant	10
Contracts per Tenant	20
vCenter	2
vShield	2

## Related Documentation

The Cisco Application Policy Infrastructure Controller (APIC) documentation can be accessed from this website:

<https://www.cisco.com/c/en/us/support/cloud-systems-management/application-policy-infrastructure-controller-apic/tsd-products-support-series-home.html>

For more information, see the following documentation:

- Cisco Application Centric Infrastructure (ACI) Simulator Documentation

## Cisco Application Centric Infrastructure (ACI) Simulator Documentation

The Cisco ACI Simulator documentation is available at the following location:

<https://www.cisco.com/c/en/us/support/cloud-systems-management/application-centric-infrastructure-simulator/tsd-products-support-series-home.html>

Cisco and the Cisco logo are trademarks or registered trademarks of Cisco and/or its affiliates in the U.S. and other countries. To view a list of Cisco trademarks, go to this URL: [www.cisco.com/go/trademarks](http://www.cisco.com/go/trademarks). Third-party trademarks mentioned are the property of their respective owners. The use of the word partner does not imply a partnership relationship between Cisco and any other company. (1110R)

Any Internet Protocol (IP) addresses and phone numbers used in this document are not intended to be actual addresses and phone numbers. Any examples, command display output, network topology diagrams, and other figures included in the document are shown for illustrative purposes only. Any use of actual IP addresses or phone numbers in illustrative content is unintentional and coincidental.

© 2017–2022 Cisco Systems, Inc. All rights reserved.