



Cisco Unified Branch

Medium Branch Deployment Guide

May 2026

Introduction

Branch offices commonly face IT challenges such as limited onsite technical resources, increased operational complexity from managing multiple disparate devices, and heightened security vulnerabilities due to fragmented solutions. These challenges are compounded by the need to scale quickly to support new technologies like AI and IoT, all while ensuring a consistent and reliable user experience across locations.

Cisco Unified Branch helps address these issues by providing an integrated, full-stack solution that consolidates essential networking and security functions—including routing, next-generation firewall, switching, and Wi-Fi—into a centrally managed solution. With Cisco Validated Designs (CVDs) and built-in automation toolkits like Cisco Workflows and Branch as Code (BaC), organizations can streamline deployment and management, reduce the risk of misconfiguration, and enforce consistent security policies. This unified approach not only simplifies branch operations but also enhances scalability, strengthens security, and delivers a seamless customer experience.

Cisco Validated Designs (CVDs) are thoroughly tested blueprints with prescriptive guidance for deploying Cisco solutions across various technologies. Cisco Unified Branch combines this validated design expertise with modern automation through Cisco Workflows and Branch as Code (BaC), allowing enterprises and partners to deploy, manage, and scale branch networks consistently and reliably, in line with modern DevOps approaches.

About this guide

The Cisco Unified Branch architecture, with supported platforms and a variety of use cases, is being developed, tested, and released in phases. This current phase supports multiple flavors of MXs, Cisco secure routers, Cisco switches, and access points at the branch using the Meraki cloud dashboard for management, and Auto VPN for the SD-WAN overlay. Catalyst switches must run in cloud mode (not device mode), meaning they must be managed and configured only from the Meraki dashboard. Small, medium, and large branch designs have been defined.

The Cisco Validated Design (CVD) documentation for Cisco Unified Branch consists of a [design guide](#) and several deployment guides. The design guide provides an overview of the Unified Branch architecture for small, medium, and large branches, discussing the hardware, services, and features supported. It also includes the configuration choices for each branch design. The deployment guides cover an example small branch, medium branch, and large branch deployment, along with step-by-step instructions on how to deploy each of them using the Meraki dashboard.

This guide covers an example Unified Branch medium branch deployment, which consists of two WAN transports, two routers deployed as a High Availability (HA) pair, two switches in a physical stack, and one access point. The deployment includes firewall policy, performance-based routing, 802.1x and Mac Authentication Bypass (MAB), QoS, Wireless guest and corporate traffic, various security and management features, Cisco Secure Access secure Internet access (SIA), Adaptive Policy, an external RADIUS server for VLAN and SGT assignment, and Thousand Eyes, Splunk, and XDR integrations.

This guide does not cover Branch as Code (BaC) or Cisco Workflows, as they are covered separately, however, the design and configuration closely reflect what is implemented by BaC and Workflows. Refer to [Appendix D](#) for additional documentation references.

Deployment example

This topology depicts a branch (Branch 2/Site 2) composed of:

- 2 MX routers in an HA pair (MX85s)
- 1 switch stack consisting of 2 MS layer-2 LAN switches (MS150-24P-4Gs)
- 1 access point (CW9172)

There are two WAN interfaces on each MX, each connected to an Internet transport. Branch 2 is configured in a hub and spoke topology, with Data Center 1 as the primary hub and Data Center 2 as the secondary. Cisco Secure Access is leveraged to provide secure Internet access (SIA) for most traffic at the branch. At the data center, multiple shared services exist, including DNS, DHCP, RADIUS, and various management platforms for SNMP, syslog, and NetFlow. For SNMP, traps from the dashboard and polling to the dashboard and devices are implemented. An external RADIUS server is leveraged for assignment of VLANs and SGT tags.

This diagram depicts a logical view of the topology:

Figure 1. Unified branch medium branch deployment example (Branch 2) logical view

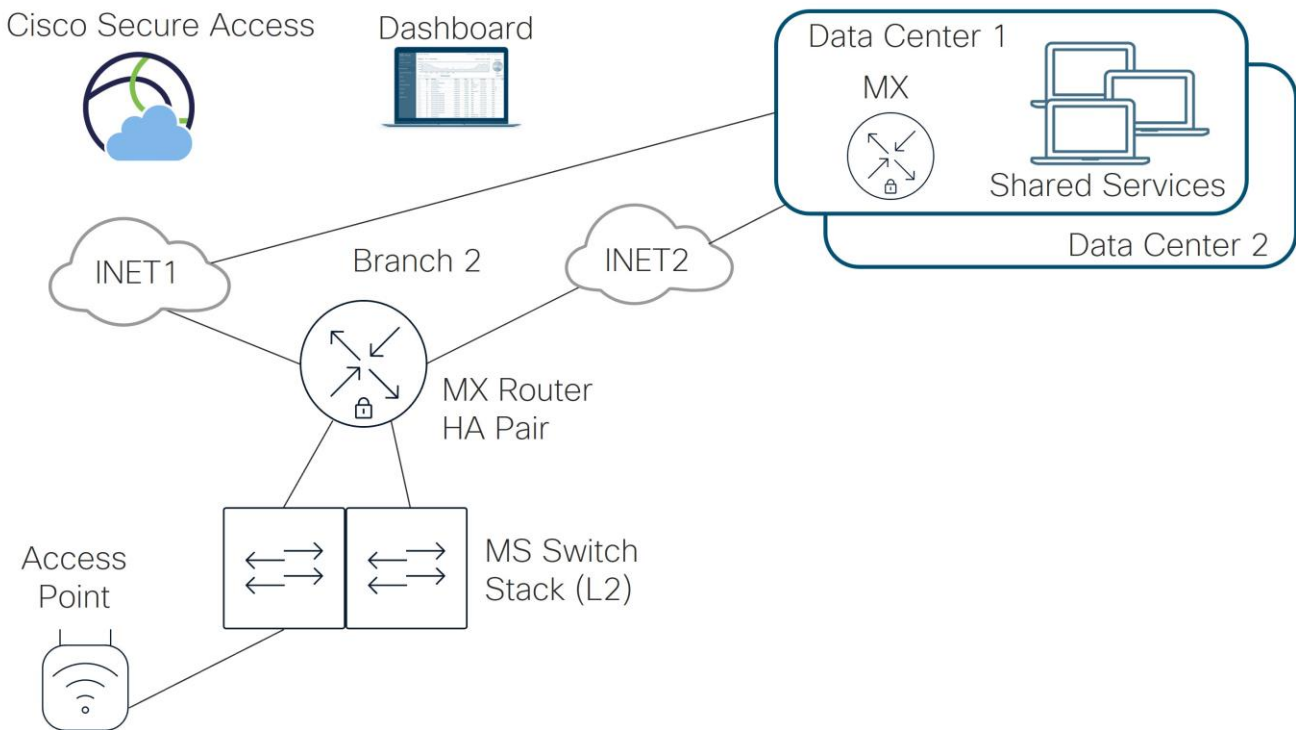

Refer to [Appendix A](#) to view the hardware models and code versions used in this example topology. New dashboard GUI versions were used wherever possible at the time of this writing (February/March 2026). Also, [Appendix B](#) reflects the dashboard and device settings that were used so the step-by-step and screenshots can be skipped.

Physical topology

In this example, the MX routers operate in active/passive mode and share access to each Internet transport. Only one MX router is active at any one time. The L2 switch stack is repurposed to front-end both Internet transports so only one connection to each transport is needed for the pair of routers. A

separate VLAN (901) is provisioned for one transport, and a separate VLAN (902) is provisioned for the other transport. These VLANs are not carried on the trunks on the LAN-side.

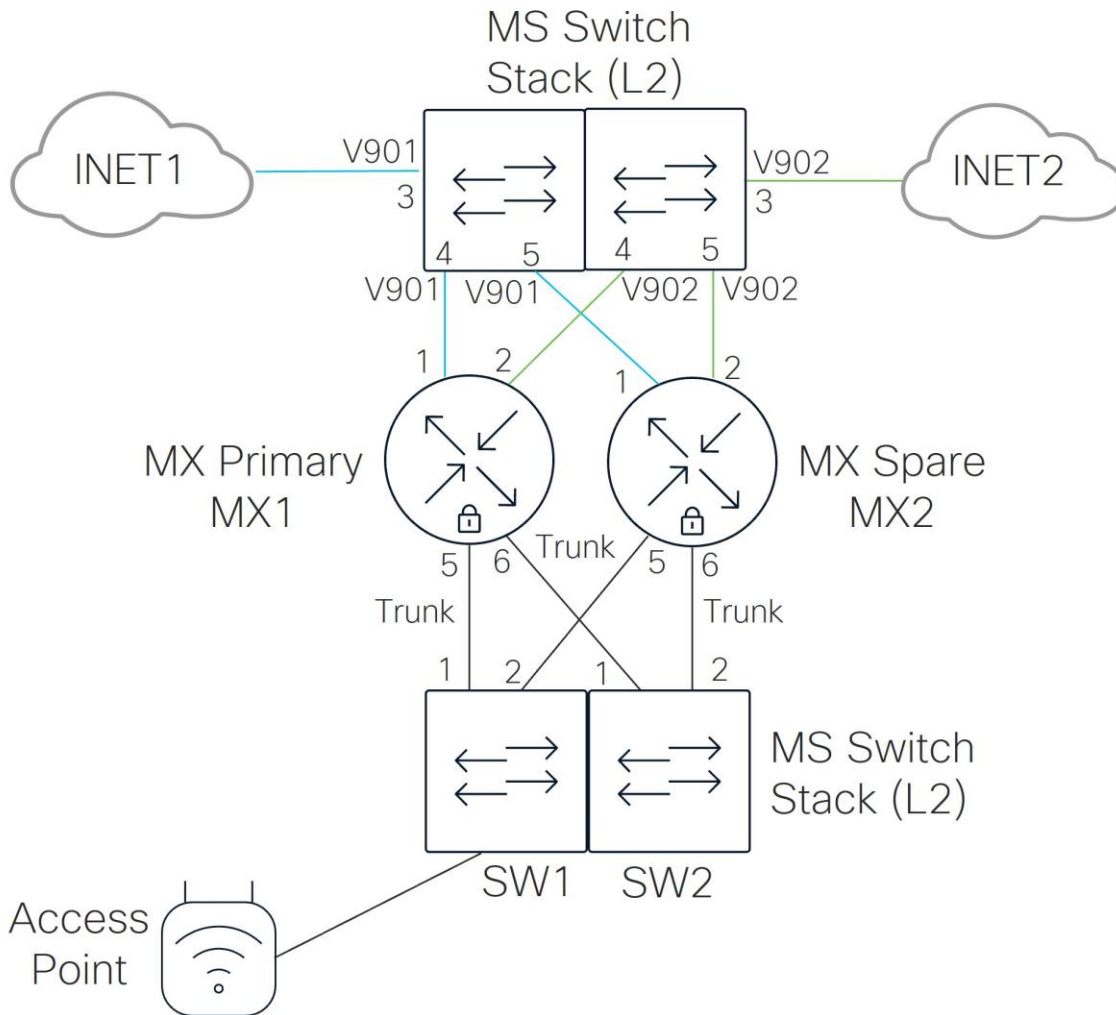

The table lists the ports used in this example:

Device	Port #	Device	Port #	Device	Port #	Device	Port #	Port configuration
SW1	3	INET1	N/A	SW2	3	INET2	N/A	Access Port (VLAN 901 or 902)
SW1	4	MX1	1 or 3	SW2	4	MX1	2 or 4	Access Port (VLAN 901 or 902)
SW1	5	MX2	1 or 3	SW2	5	MX2	2 or 4	Access Port (VLAN 901 or 902)
SW1	1	MX1	5	SW2	1	MX1	6	Trunk Port (VLANs 1 (NATIVE),10,20,30,40,50,999)
SW1	2	MX2	5	SW2	2	MX2	6	Trunk Port (VLANs 1(NATIVE),10,20,30,40,50,999)
SW1	9	Access Point	0					Trunk Port (VLANs 1,10,20,30,40,50,999(NATIVE))

On the switches, these additional ports in this table are reserved for infrastructure, AP connections, and devices:

Device	Port #	Device	Port configuration
MX1	7-14	Unused	Disabled
SW1 or SW2	6-8	Any Infrastructure	Disabled
SW1 or SW2	10-12	Dedicated to APs	Disabled
SW1 or SW2	13-24 or 13-48	Dedicated to Devices	Disabled

Tech tip: On the MX router, if the backup WAN interface will be enabled at some point, plan using the SFP ports, physical ports 1 and 2 from the beginning (instead of ports 3 and 4). When the backup WAN port is enabled, it will use physical port 4 and move the Internet ports to physical port 1 and 2 (SFP ports). Enabling the backup WAN interface will cut off Dashboard control traffic to the devices if ports 3 and 4 are actively being used for Internet access. If you add SFP modules to a running system, the MX will need a reboot in order to detect and start utilizing port 1 (or 3). Alternatively, the active port can be specified by configuring the port through the local status page.

Network description

These details further describe the network:

- The MX routers for the hubs and branch are deployed in routed mode.
- There is an active MX router and a passive MX router. Each MX connects to a switch which gives each MX access to the same Internet transport through a shared VLAN. In this example, the MX routers leverage a virtual uplink IP address that is shared when sending traffic to the Internet. This virtual uplink IP address must be in the same subnet as the IP addresses of the MXs and also must be different from both MX uplink IP addresses.
- This table describes the seven interface VLANs that are defined on the MX router. The subnet structure is designed so global firewall rules can be minimized. SITE# refers to Branch/Site “2” in this example. DHCP can be local to the branch or relayed to the data center to a centralized DHCP server. The DNS server can be located on the Internet or at the data center. Some VLANs are not advertised across the auto VPN overlay (indicated by **Disabled** under the **VPN Mode** column).

VLANs	Subnet structure	DHCP location	DNS location	VPN mode
VLAN 1 (Default)	192.168.128.0/24	Local	Internet (Use OpenDNS)	Disabled
VLAN 10 (DATA)	10.<VLAN#>.<SITE#>.0/24	Data Center	Data Center	Enabled
VLAN 20 (VOICE)	10.<VLAN#>.<SITE#>.0/24	Data Center	Data Center	Enabled
VLAN 30 (IOT)	10.<VLAN#>.<SITE#>.0/24	Data Center	Data Center	Enabled
VLAN 40 (PCI)	10.<VLAN#>.<SITE#>.0/24	Data Center	Data Center	Enabled
VLAN 50 (GUEST)	172.16.99.0/24	Local	Internet (Use OpenDNS)	Disabled
VLAN 999 (INFRA)	10.250.<SITE#>.0/24	Local	Data Center	Enabled

- VLAN 1 is used for initial onboarding to the dashboard, then all device management is switched to tagged VLAN 999 with unique addressing so this traffic can use the various services in the data center, such as syslog, NetFlow, and SNMP services. One exception is the Access Point. The switch trunk to

each access point is configured for native VLAN 999 so the AP management traffic has reachability in VLAN 999.

- In general, traffic from one VLAN cannot access another VLAN due to firewall rules. Exceptions are made for shared services (DATA subnet can access printer services within the branch and DATA, IOT, VOICE, PCI, and INFRA subnets can access shared services within the data center). Guest and Default VLAN traffic and some traffic from the DATA and INFRA VLANs are permitted to go out Direct Internet Access (DIA).
- The WAN uplinks on the MX router are set to rate limit on the provider sub-line rate, and VPN tunnels are formed on both WAN transports. No load-balancing is done for direct Internet traffic. Internet break-out traffic, or direct Internet traffic, is confined to Guest and Default VLAN traffic, a few corporate SaaS applications, and dashboard traffic for the INFRA VLAN for downstream devices (switch and AP dashboard traffic). All other traffic that is Internet-bound goes through Cisco Secure Access tunnels at the site.
- Active/standby tunnels are set up from the active MX router to Cisco Secure Access. One pair of active/standby tunnels are sourced from one WAN transport (INET1) and another pair of active/standby tunnels are sourced from the second WAN transport (INET2). The tunnels leverage health checks. Traffic to the active tunnels is load balanced by default.
- Performance-based routing is enabled for corporate SaaS traffic using the Internet break-out, and VoIP and video conferencing, a custom critical application, and default traffic using the Auto VPN overlay.
- All switch trunk port connections in this example carry just the VLANs defined on the MX router, including the native VLAN 1. The native VLAN is defined as 999 on trunk ports to any AP.
- Each MX router has one trunk connection to each switch of the 2-switch stack, and all other ports on the MX are unused (ports 7-14). The unused ports on the MX are disabled. Each switch has ports designated for Infrastructure that are unused (ports 6-8) in this example and are shutdown. The AP port in this example is configured as a trunk, and all unused AP trunk ports are disabled. The left-over ports on each switch are configured as access ports and are configured for BPDU guard and 802.1x/MAB. All ports are enabled for rapid spanning-tree and storm control.
- Adaptive Policy is enabled. Four groups are defined as part of DATA VLAN 10 (Finance_User_Group, Marketing_User_Group, Finance_Server_Group, and Marketing_Server_Group). It is assumed that the servers reside in the data centers, while the users reside in the branch. A policy is defined that dictates the permissions between groups. Configurations are set to ensure that SGT tags are trusted/propagated across the Auto VPN and between the MX/switch and switch/AP.
- 802.1x enabled on the access ports of each switch leverage an external server configured for RADIUS authentication and accounting. Multi-Auth mode is used. The policy type is hybrid authentication, meaning, if there is no authentication for 802.1x, Mac Authentication Bypass (MAB) can be used instead. Voice authentication is also enabled. There is no access to the network if either 802.1x or MAB authentication fails. If authentication succeeds, a VLAN is passed back from the RADIUS server, putting the user into the DATA, VOICE, IOT, or PCI VLANs. An SGT tag is also passed back from the RADIUS server. In this example, ISE (version 3.4) is used as the external RADIUS server. Refer to [Appendix C](#) for ISE settings used in this example.
- For QoS on each switch, the GUEST VLAN traffic DSCP is not trusted and set to DSCP 0. For other VLAN traffic, DSCP is trusted. On the MX router, default traffic rules are used, and rules are added to include guest traffic and custom critical application traffic.
- Wireless guest traffic is configured for Open authentication (no encryption), mandatory DHCP, and a click-through splash page which must be acknowledged before being allowed on the network. DHCP is performed by the MX router and traffic is tagged for the GUEST VLAN (VLAN 50). Layer 2 LAN isolation is enabled so guest users cannot communicate with each other, and a per-client bandwidth and per-

SSID bandwidth limit is enabled. SSID availability is scheduled according to a custom schedule. The Guest Wi-Fi uses 2.4 and 5 GHz bands and AI-RRM is enabled.

- Corporate Wi-Fi traffic is configured to use 802.1x Enterprise authentication with RADIUS (authentication and accounting). WPA3 transition mode is used, and fast roaming and protected management frames are enabled (protected management frames allow unsupported clients). DHCP is performed by the MX router and by default, traffic is tagged for the DATA VLAN, although the Override VLAN tag is enabled. RADIUS will respond back with a group policy name (DATA, VOICE, IOT, or PCI) which has a VLAN set based on the identity of the user. Separately, an SGT tag is passed back. SSID availability is scheduled according to a custom schedule. The Corp Wi-Fi uses 2.4, 5, and 6 GHz bands, band steering, and AI-RRM is enabled.
- Wi-Fi 7 is not enabled yet for the Corporate Wi-Fi as it requires a separate access point from the guest Wi-Fi due to security requirements. Per-group SSID configuration is available starting in MR release 32.1.4, where Wi-Fi 7-compliant SSIDs can co-exist on the same AP as non-Wi-Fi 7-compliant SSIDs as long as they are in separate SSID groups. The feature is still in Beta status as of 32.1.5, hence why it is not included yet in the Unified Branch design. Refer to the [WPA3 Encryption and Configuration Guide](#) for additional information.
- Splunk, Thousand Eyes, and XDR are deployed in the example network.

For this deployment, these steps are discussed:

Step 1. [Complete the prerequisites](#)

Step 2. [Create a new network](#)

Step 3. [Onboard the devices](#)

Step 4. [Upgrade devices \(if needed\)](#)

Step 5. [Configure devices](#)

Step 6. [Verify device operation](#)

When the devices are onboarded, configured, and verified, configuration templates can optionally be created then modified from the configured network which can then be used to quickly deploy additional branches. Refer to the [Managing Multiple Networks with Configuration Templates](#) for more details.

Complete the prerequisites

There are several prerequisites that need to be addressed before configuration and onboarding can begin. This includes ensuring Internet connectivity for the network devices, creating a Meraki dashboard account and Organization within the dashboard, ensuring the network devices are added to the Organization Inventory in the dashboard, ensuring the required licenses are added to the dashboard, and having account access for the feature integrations (Cisco Secure Access, ThousandEyes, Splunk, and XDR). There may also be hardware, software, and licensing requirements for certain features. Refer to the [Cisco Unified Branch Design Guide](#) for additional information.

Internet connectivity

All configurations can be performed on the Meraki cloud dashboard. Devices should have connectivity to the Internet to connect to the Meraki cloud. Device onboarding is simplified if the provider provides an IP address, gateway, and DNS information through DHCP to the WAN uplink on the MX router, as device registration to the dashboard is automatic. In addition, it is important to ensure that if there are any firewalls upstream from the router, the proper rules are configured so the device can reach the proper cloud services. Refer to [Upstream Firewall Rules for Cloud Connectivity](#) for details on what IP addresses and ports should be allowed.

Meraki dashboard account and organization

Ensure a Meraki dashboard account and organization are created. The organization is created at the same time as the account. From the account, organizations, networks, and devices are managed. An organization is made up of multiple networks, and each network is made up of one or more devices. A network typically correlates to a physical location. Refer to [Creating a Dashboard Account and Organization](#) for more information.

Organization device inventory

Ensure the devices to be managed are added in the Organization inventory on the dashboard (**Organization > Configure > Inventory**).

The inventory page contains all devices in the organization, including those that have been added to networks as well as those that are not currently assigned to a network within the organization. Devices must first be claimed before being able to be used or assigned to a network in the Dashboard.

Devices can be entered using an order claim key or cloud ID. The preferred method is using the order claim key as this ensures that all hardware from an order is claimed. The order claim key can be found in order shipment email notifications or in the corresponding Cisco Commerce Workspace (CCW) order under the Order Claim Key field.

Note: If your order includes software subscription licenses, you can also claim the subscription along with your hardware using the order claim key.

Procedure 1. To claim devices using the order claim key:

Step 1. Go to **Organization > Configure > Inventory** and select **+ Claim devices**.

Step 2. In the pop-up window, enter the order claim key then click **Claim order**.

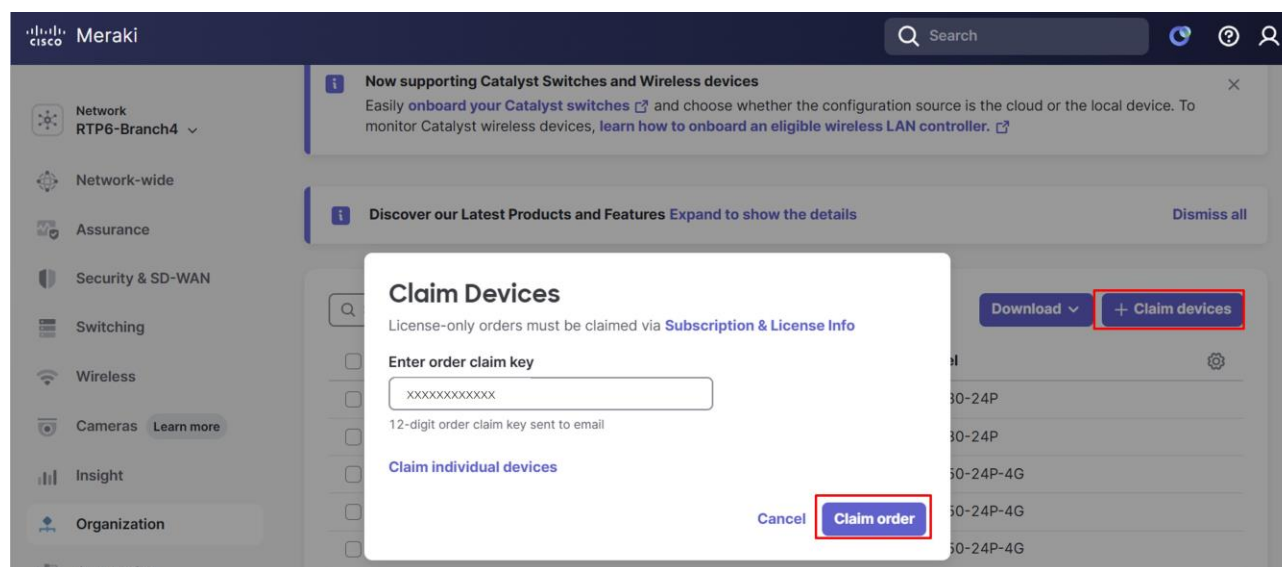

Individual devices can also be claimed. The Cloud ID for a device is a unique identifier used for claiming and managing the device in the Meraki dashboard. For individual Meraki devices, the serial number and cloud ID are the same and can be found in the order shipment email notifications or on the devices themselves.

Procedure 2. To claim individual devices:

Step 1. Go to the **Organization > Configure > Inventory > + Claim** devices pop-up window.

Step 2. Select **Claim individual devices**.

Step 3. Enter the **Device Cloud ID** (Meraki serial number) then click **Claim devices**.

For individual Catalyst devices, the device serial number and cloud ID are not the same. The Meraki dashboard accepts only the cloud ID for claiming and managing these devices. For -M devices, the Cloud ID can be found in the order shipment email notifications, or you may find a cloud ID label on the device. Also, if you are on the console while it boots, you can view the model number, serial number, cloud ID, and mac address before it becomes Meraki-managed.

```
Booting in Meraki mode

Switch          Serial          Cloud ID        Mac Address     Migration      Mode
Num    PID          Number          ID              Address         Status
-----
1      C9200L-24P-4G    FJC29341M8K    Q5FL-WLZK-NP9Q 68d9:7273:7800 Registered    C9K-M

Please go to dashboard.meraki.com to manage above device(s).
You can locate the device(s) on the Meraki Dashboard using the Cloud ID(s).

Starting Meraki app...

service meraki connect is enabled.
█
```

Opened session: Unified-Branch-Starlink-Lab/DMZ Infrastructure/Q24-T5 [SSH] 1.4.0.9 <Auto Restore> ...

For non -M Catalyst devices, the cloud ID is generated from the CLI after upgrading the switch to the minimum IOS XE image, which is IOS XE 17.15, but some models require IOS XE 17.18. Refer to [Conversion from CLI-managed IOS XE Catalyst Switches to Cloud Management with Cloud Configuration](#).

For additional information on onboarding, refer to the [Meraki Hardware and Software Onboarding Guide](#).

Licenses

Every device requires an active license. A license provides access to the Meraki Dashboard for cloud-based management and monitoring, offers support and firmware updates, and unlocks specific features depending on the product. Subscription licensing is recommended. If a subscription expires, after a grace period, the ability to manage devices is lost for all networks bound to that subscription.

Ensure the required licenses are added to the dashboard. License status can be found on the **Organization > Configure > License Info** page on the dashboard. Licenses are added automatically if they are part of an order number that was entered in the Inventory page, otherwise, they can be added manually using a Claim Key if the order number is not known or the license is ordered separately from the devices.

For more detailed information, review the [Getting Started Checklist](#).

In addition to device licensing, additional licensing may be required depending on the feature. Refer to the [Cisco Unified Branch Design Guide](#) for more information about feature licensing and hardware and software requirements.

Create a new network

Procedure 3. To create a new network:

Step 1. On the dashboard, go to **Organization > Configure > Create Network**.

Step 2. In the text box, enter the **Network name** (RTP6-Branch2) and specify the **Network type** (if needed, from the drop-down menu (Combined hardware)). Before additional configurations are added, this network uses the **Default Meraki configuration**.

Step 3. Select the devices from inventory that should be included in the network (these should have been added during the prerequisite steps).

Step 4. Select **Create network**.

Set up network

Networks provide a way to logically group, configure, and monitor devices. This is a useful way to separate physically distinct sites within an Organization.

Network name

Network type ⓘ

Network configuration

Default Meraki configuration

Bind to template ⓘ

Clone from existing network

Select devices from inventory

Choose the devices in your inventory you'd like to add to this network.

If Catalyst devices are added, a window may appear to indicate the device management and configuration source before adding those devices to the network. Devices can be in cloud mode, where configuration is sourced from the Meraki Dashboard, or in device mode where the configuration is local to the device. In Unified Branch, only cloud mode is supported at this time.

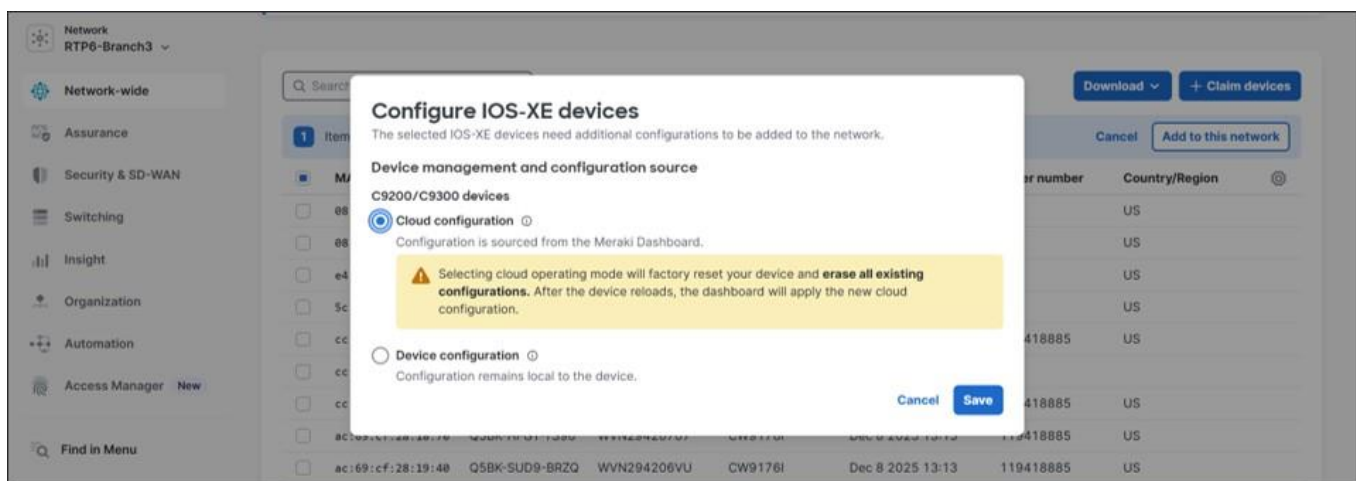

The dashboard switches to the newly created network.

Tech tip: The local status page on a network device can be accessed to make limited local configuration changes and perform local troubleshooting. As of August 1, 2025, if a local status page password was not set at the time of network creation, one is automatically generated and cannot be viewed. When a device connects to the Dashboard, the password that was automatically generated becomes the new local status page password for that device. It is recommended to change the local status page password under **Network-wide > Configure > General > Device configuration > Local credentials** when a network is created. When a device has never connected to the Dashboard, its local status page default username is *admin* and the password is the device's serial number (including upper-case letters and dashes).

Procedure 4. To set the local status page password for the devices connecting to this network:

Step 1. Under the new network, navigate to **Network-wide > Configure > General**. The local device status page is enabled by default.

Step 2. Under **Device configuration > Local credentials**, click **Change password**.

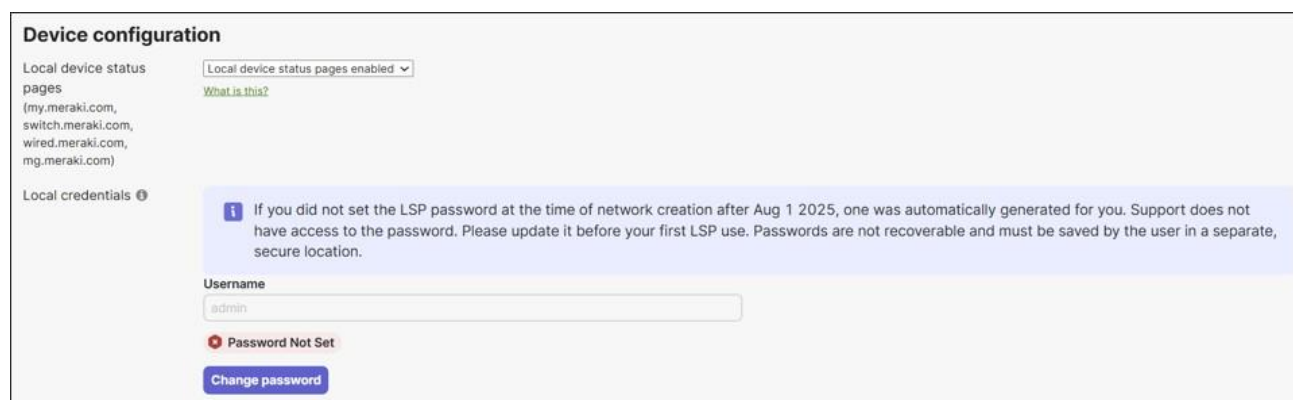

The screenshot shows the 'Device configuration' page. Under 'Local device status pages', there is a dropdown menu set to 'Local device status pages enabled' and a link 'What is this?'. Below this, under 'Local credentials', there is an information icon and a message: 'If you did not set the LSP password at the time of network creation after Aug 1 2025, one was automatically generated for you. Support does not have access to the password. Please update it before your first LSP use. Passwords are not recoverable and must be saved by the user in a separate, secure location.' Below the message is a text input field for 'Username' containing 'admin'. A red notification 'Password Not Set' is displayed. At the bottom, there is a blue 'Change password' button.

Step 3. Under **Password**, type a secure password, which must be 14 characters long and must include a number, uppercase letter, lowercase letter, and a symbol.

Step 4. Click **Update password**.

Step 5. Click **Save**.

Step 6. You may need to reload the web page to remove the “Password Not Set” notification outlined in red. Remember this password because it won’t be visible in the dashboard when set.

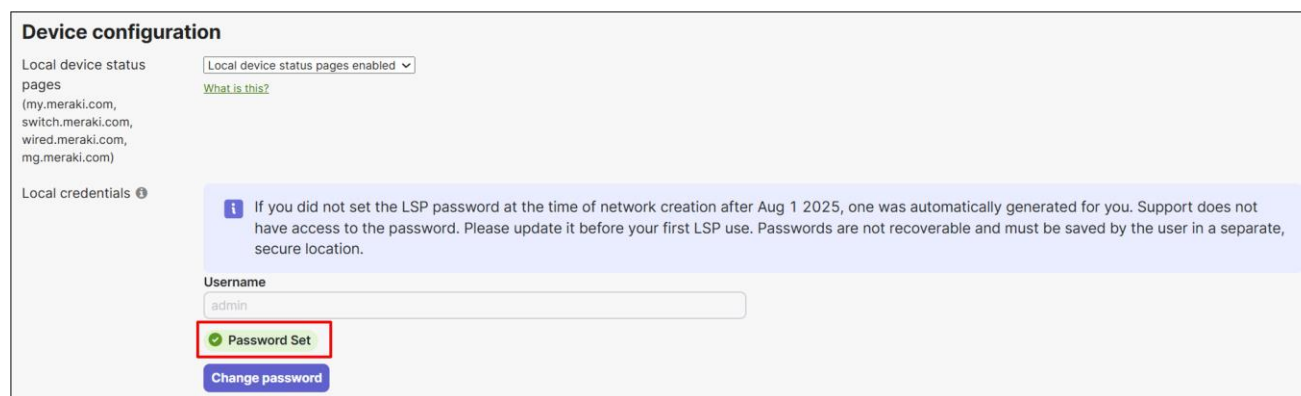

The screenshot shows the 'Device configuration' page after the password has been set. The 'Local credentials' section now displays a green notification: 'Password Set'. The 'Username' field still contains 'admin'. The 'Change password' button is still present at the bottom.

Onboard the devices

For onboarding, the primary MX router is onboarded first, followed by the switches, APs, and spare MX router. The cabling is then completed. As part of the cabling completion, the switches are moved between the MX routers and Internet transports.

These instructions assume the devices are powered off and not initially cabled:

Onboard the primary MX router

Procedure 5. To onboard the primary MX router:

Step 1. Ensure the MX router can get a DHCP lease and internet connectivity from at least one of the WAN connections so the MX can connect to the dashboard.

Step 2. If IP addressing to the service provider must be manual:

- a. Connect locally to the MX.
- b. Add an IP address, netmask, gateway, and DNS information to Internet 1 (physical port 1 (SFP) or 3 (RJ45)) or Internet 2 (physical port 2 (SFP) or 4 (RJ45)).

Refer to [Cisco Meraki Local Status Page: Overview](#) and [Cisco Meraki Local Status Page: Security and SD-WAN](#) for additional information. This example assumes DHCP is available from both internet service providers.

Step 3. Power the primary MX router on and connect WAN interface 1 (SFP port 1 in this example) to its WAN transport.

When it reaches the dashboard, a firmware upgrade may take place to update the device to the latest stable release. When the LED on the router turns solid white, the MX is connected to the dashboard, and its default configuration should be downloaded.

Onboard the switches

Procedure 6. To onboard the switches:

Step 1. After the MX router is fully on board and while the switches are still powered off, cable the switches together using their stacking cables.

- Stack port 1 switch 1 → stack port 2 switch 2
- Stack port 2 switch 1 → stack port 1 switch 2

Refer to [Switch Stacks](#) if needed for additional information.

Step 2. Connect the uplink of switch 1 (port 1) to the proper port on the primary MX router (port 5).

Step 3. Connect the uplink of switch 2 (port 1) to the proper port on the primary MX router (port 6).

Step 4. Power on the switch stack.

Wait for both switches to be completely onboarded. When the switch management traffic reaches the dashboard, a firmware upgrade may take place to update the devices to the latest stable release. When the LED on the switch is solid white, the switch is connected to the dashboard, and its default configuration should be downloaded.

Onboard the Access Point (AP)

Procedure 7. To onboard the AP:

- After both switches in the switch stack are fully onboard, connect the uplink of the AP to the proper port on the switch (switch 1 port 9 in this example).

Through PoE, the AP is powered on. After AP management traffic reaches the dashboard, a firmware upgrade may take place to update the device to the latest stable release. When the LED on the AP is solid white, the AP is connected to the dashboard, and its default configuration should be downloaded.

Modify switch configurations

Stack configuration

Procedure 8. To configure a stack:

Step 1. Ensure that the switches are recognized as part of a stack on the dashboard.

Step 2. Under the newly created branch (RTP6-Branch2), go to **Switching > Monitor > Switch Stacks**.

If the stack was auto-provisioned by the dashboard, it shows up as a **Stack Name** with the listed **Stack Members** in mac addresses form.

The screenshot shows the 'Switch Stacks' dashboard. At the top right is a '+ Create stack' button. Below it is a search bar with the text 'Search by name, serial, or mac' and a 'Device type' dropdown menu. To the right of the search bar, it says '1 result'. A 'Delete stack(s)' button is located to the right of the search bar. Below the search bar is a table with two columns: 'Stack name' and 'Stack members'. The table contains one row with a checkbox, the name 'Stack - 1', and two MAC addresses: '5c:06:10:5f:67:2e' and '6c:c3:b2:7f:a7:40'.

Step 3. To change the stack name, click the **Stack name** (Stack - 1), then click the edit symbol next to the stack name.

The screenshot shows the configuration page for 'Stack - 1'. At the top left, it says 'SWITCH STACKS'. Below that is the title 'Stack - 1' with an edit icon (a pencil inside a square) next to it. Below the title are four tabs: 'Overview', 'Manage members', 'Clone and replace member', and 'Layer 3 routing'. Below the tabs is the text 'Members (2)' followed by a link that says 'configure ports in this stack'.

Step 4. Edit the name (B2-SW-STACK1) then click **Save**.

Step 5. Navigate back to the **Switching > Monitor > Switch Stacks** page.

Switch Stacks

[+ Create stack](#)

Configured stacks

1 result
[Delete stack\(s\)](#)

Stack name	Stack members
<input type="checkbox"/> B2-SW-STACK1	5c:06:10:5f:67:2e 6c:c3:b2:7f:a7:40

Rows per page 1-1 of 1 < >

Step 6. (Optional) If the switch stack was not detected automatically, the stack can be manually created by:

- a. Click **Create stack**.
- b. Enter the **Stack name**.
- c. Select the stack members.
- d. Click **Create**.

Create Stack

Stack name

2 results

Name	Serial number	Model
<input checked="" type="checkbox"/> 6c:c3:b2:7f:a7:40	Q4GP-GXCM-8VQ9	MS150-24P-4G
<input checked="" type="checkbox"/> 5c:06:10:5f:67:2e	Q4GP-HRQT-D47J	MS150-24P-4G

Rows per page 1-2 of 2 < >

[Cancel](#) [Create](#)

Switch naming

Procedure 9. To name a switch:

Step 1. Under the new branch, go to **Switching > Monitor > Switches**.

Step 2. Select one of the switches.

Step 3. Click the edit symbol next to the mac address in the top left corner and enter the **Switch name** (B2-SW1).

Step 4. Click **Save**.

In this example, B2-SW1 is the switch connecting to the first Internet transport and the one connecting to the AP.

Step 5. Repeat the process with the other switch (B2-SW2).

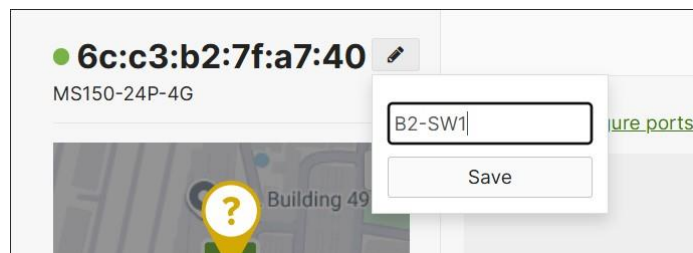

Allowed VLANs trunk configuration

By default, switches carry all VLANs on trunks.

In the MS models, the **Allowed VLANs** on trunks are configured as “all”, which equates to VLANs 1-4094.

In the C9300/C9200 models, allowed VLANs are represented on trunks as 1-<# of active VLANs>.

For some switch models, active VLANs are 1000. For some switches, it is less.

In the case of the 9200L-M, the number of active VLANs supported when spanning-tree is enabled is 512. VLANs above 512 cannot be added unless other VLANs are pruned off the trunks.

In this section, for any switches supporting less than 999 VLANs, all ports are configured as trunks carrying VLANs 1,10,20,30,40,50,999. Individual ports may be modified later.

Procedure 10. To modify VLANs allowed on trunk ports:

Step 1. Go to **Switching > Monitor > Switch Ports**. If all switches have trunks with an **Allowed VLANs** setting of “all”, or “1-N”, where N is greater than or equal to 999, skip to [Transport configuration](#).

Step 2. For any switches that support active VLANs < 999, pick a switch one at a time, select all ports on the switch, then click **Edit**.

Step 3. Next to **Allowed VLANs**, type in 1,10,20,30,40,50,999 then click **Update**.

Note: There are no switches to update in this example.

Transport configuration

The switch configurations should be modified to accommodate the WAN transport connections.

Procedure 11. To configure the transport VLANs:

Step 1. Go to **Switching > Monitor > Switch Ports**.

Step 2. On the switch connected to the first WAN transport (B2-SW1), select ports 3, 4, and 5, then at the top of the page, click **Edit**.

Step 3. Enter the **Name** (INET1).

Step 4. Select **Type Access** and enter the **VLAN** (901).

Step 5. Click **Update**.

Update 3 ports ✕

Settings are applied to all ports selected, including all ports in aggregate groups

Switch / Port	B2-SW1 / 3 B2-SW1 / 4 B2-SW1 / 5
Name	<input type="text" value="INET1"/>
Port status	Enabled Disabled
Link negotiation	<input style="width: 100%;" type="text" value="Auto negotiate"/>
Port schedule	<input style="width: 100%;" type="text" value="Unscheduled"/>
Tags	<input style="width: 100%;" type="text" value="+"/>
Port profile name	<input style="width: 100%;" type="text"/>
Type	Trunk Access
Access policy ⓘ	<input style="width: 100%;" type="text" value="Open"/>
VLAN	<input style="width: 100%;" type="text" value="901"/>

Cancel
Update

- Step 6.** Remove VLAN 901 from the trunk ports going to the MX routers on B2-SW1.
- Step 7.** On this same page, select ports 1 and 2, then at the top of the page, click **Edit**.
- Step 8.** Enter the **Name** (Uplink to Router) and next to **Allowed VLANs**, enter the VLANs to be configured on the MX router (1, 10, 20, 30, 40, 50, 999).
- Step 9.** Click **Update**.

Update 2 ports ✕

Switch / Port: B2-SW1 / 1
B2-SW1 / 2

Name:

Port status: Enabled Disabled

Link negotiation:

Port schedule:

Tags:

Port profile name:

Type: Trunk Access

Access policy:

Native VLAN:

Allowed VLANs:

Cancel
Update

Step 10. Repeat for the second switch (B2-SW2). For ports 3, 4, and 5, the port **Name** should be set to INET2, the **Type** to **Access**, and the **VLAN** to 902.

<input type="checkbox"/>	<div style="background-color: #008000; height: 15px; width: 100%;"></div>	B3-SW2 / 1 details	trunk	native 1	1-1000
<input type="checkbox"/>	<div style="border: 1px solid #ccc; height: 15px; width: 100%;"></div>	B3-SW2 / 2 details	trunk	native 1	1-1000
<input type="checkbox"/>	<div style="border: 1px solid #ccc; height: 15px; width: 100%;"></div>	B3-SW2 / 3 - uplink details	INET2	access 902	-
<input type="checkbox"/>	<div style="border: 1px solid #ccc; height: 15px; width: 100%;"></div>	B3-SW2 / 4 details	INET2	access 902	-
<input type="checkbox"/>	<div style="border: 1px solid #ccc; height: 15px; width: 100%;"></div>	B3-SW2 / 5 details	INET2	access 902	-



Note: To view any missing columns, click the gear in the top right corner of the column headers and select the needed category under **Configuration**. Click outside the box to return. Move columns as needed.

Step 11. Remove VLAN 902 from the trunk ports going to the MX routers on B3-SW2.

Step 12. On this same page, select ports 1 and 2, then at the top of the page, click **Edit**.

Step 13. Enter the **Name** (Uplink to Router) and next to **Allowed VLANs**, type in the VLANs to be configured on the MX router (1, 10, 20, 30, 40, 50, 999).

Step 14. Click **Update**.

<input type="checkbox"/>		B2-SW2 / 1 - uplink details	Uplink to Router	trunk	native 1	1,10,20,30,40,50,999
<input type="checkbox"/>		B2-SW2 / 2 details	Uplink to Router	trunk	native 1	1,10,20,30,40,50,999

Complete the cabling

After the switch configurations have been modified, the cabling can be completed.

Note: The spare MX router is still powered off at this point.

Procedure 12. To complete the cabling:

Transport cabling

Step 1. The switch stack is inserted between the transports and the MX routers. Move the cable from port 1 on the primary MX router to port 3 on switch 1 (B2-SW1) so switch 1 is connected to the first Internet transport provider (INET1).

Step 2. On switch 2 (B2-SW2), cable the connection from port 3 to the second Internet transport provider (INET2).

Cable these ports:

- Switch 1 port 4 → Primary MX router port 1
- Switch 1 port 5 → Spare MX router port 1
- Switch 2 port 4 → Primary MX router port 2
- Switch 2 port 5 → Spare MX router port 2

LAN cabling

The LAN cabling for the spare MX router is completed.

Step 3. Cable these ports:

- Switch 1 port 2 → Spare MX router port 5
- Switch 2 port 2 → Spare MX router port 6

Onboard the spare MX router

Note: When an MX is added to a network that already contains an active MX of the same model type, the new MX will automatically be added to the network in warm spare mode.

Procedure 13. To onboard the spare MX router

Step 1. Power the spare MX router on.

When the management traffic reaches the dashboard, a firmware upgrade may take place to update the device to the latest stable release.

When the LED on the router turns solid white, the MX is connected to the dashboard, and its default configuration should be downloaded.

The new MX should show up in the Dashboard as a warm spare.

Step 2. View the status of the spare MX router by selecting the preferred **Network** (RTP6-Branch2) and going to **Security & SD-WAN > Monitor > Spare Status**.

Upgrade devices (if needed)

The primary and spare MX routers are upgraded to the latest stable release candidate/latest recommended version at the time of this writing (19.2.7) to pick up an additional feature (active/active tunnels for Cisco Secure Access).

Note: When selecting to upgrade the MX routers in a primary/spare pair, the routers cannot be specified separately. Both primary and spare MX routers are upgraded but steps are taken to attempt a zero-downtime MX upgrade, meaning, the primary is upgraded after the spare MX becomes active, then the spare MX is upgraded after the primary MX becomes active again.

For additional information, refer to [MX Warm Spare - High-Availability Pair](#).

Procedure 14. To upgrade devices (if needed):

- Step 1.** Go to **Organization > Monitor > Firmware Upgrades**.
- Step 2.** Click the **Schedule upgrades** tab.
- Step 3.** Specify the search criteria and select the MX router to upgrade (RTP6-Branch2).
- Step 4.** Click **Schedule upgrades**.

Network	Device type	Current firmware	Firmware type	Status	Availability	Upgrade scheduled
<input checked="" type="checkbox"/>	RTP6-Branch2	Security appliance	MX 19.1.1	Recommended	Warning - August 04, 2026	Upgrade available No

Step 5. In the next window, select the **Target firmware version** then click **Next**.

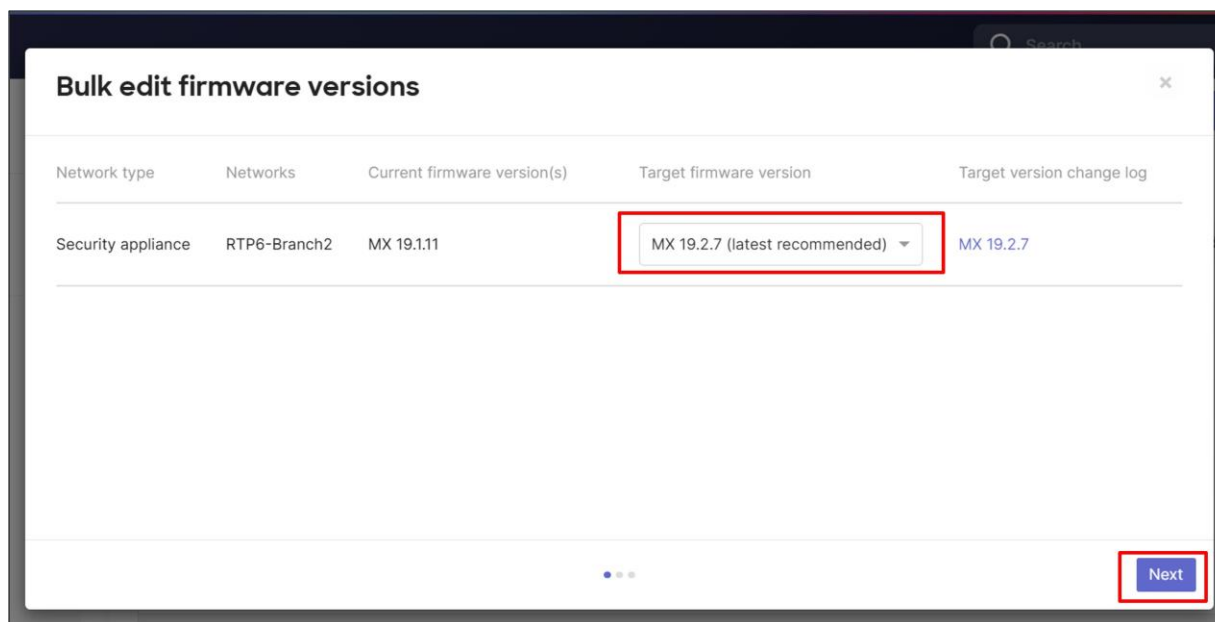

Step 6. Under **Schedule firmware change**, select **Perform the upgrade now** and click **Next**.

Step 7. Under **Change summary**, review the firmware change and select **Schedule change for 1 network**.

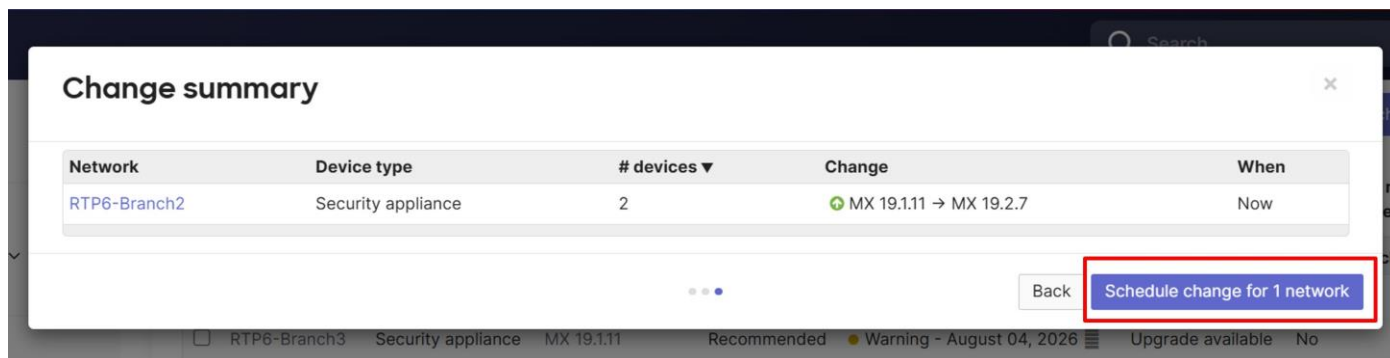

The dashboard schedules the upgrade (within 5 minutes). After the primary MX router is upgraded, the secondary MX router waits for several minutes to ensure the primary is stable before continuing with its upgrade.

Step 8. When the upgrade is complete, and both MX routers are again reachable, verify the MX version under **Security & SD-WAN > Monitor > Appliance Status** under the **Network RTP6-Branch2**.

For the MX spare version, go to **Security & SD-WAN > Monitor > Spare Status**.

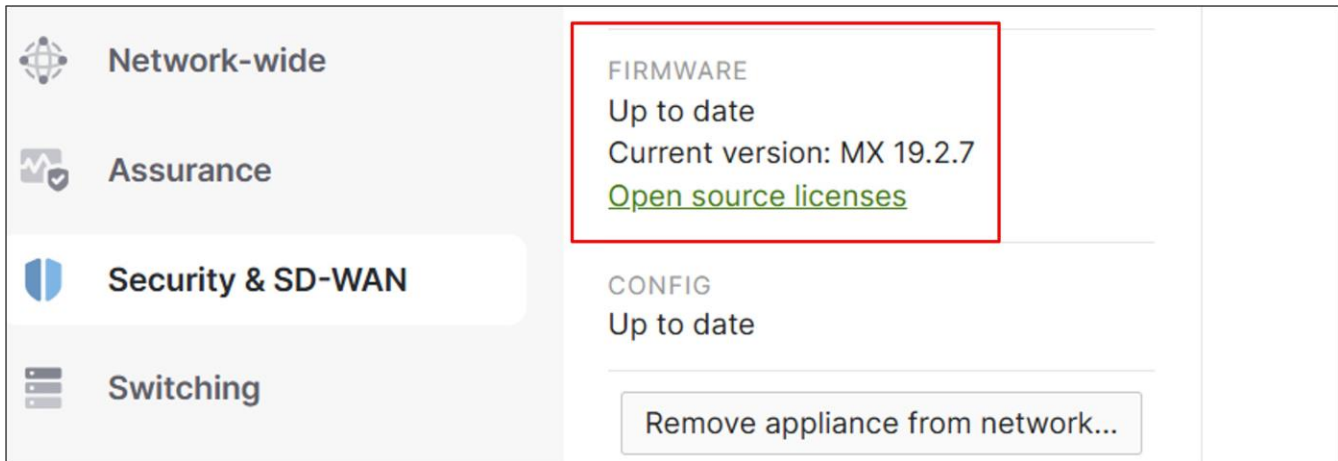

Step 9. Go to **Network-wide > Monitor > Event Log** to view the network events as the devices are upgraded.

Step 10. Repeat the steps if needed for any additional devices.

Configure devices

In this example, the devices have already been cabled and onboarded to the Meraki Dashboard. The switches and AP use VLAN 1 to reach the dashboard through the primary MX router. In general, the network is configured in this order:

1. The network devices are named and their locations set. The time zone is configured for the network and hostname visibility is configured for traffic analysis.
2. The primary MX router is configured for a virtual uplink IP address for the WAN. It is then configured for VLANs, DHCP, site-to-site VPN settings, firewall rules, Cisco Secure Access tunnels, local Internet breakout, SD-WAN policies, traffic shaping, threat protection, and content filtering.
3. The switches and AP are then moved into the INFRA VLAN 999.
4. The switch stack is then configured for spanning-tree, Quality of Service (QoS), storm control, port access policies (802.1x/RADIUS), and the rest of the ports are then configured.
5. The wireless Guest SSID is set up, group policy is configured, corporate SSID is set up, and SSID availability and radio settings are configured.
6. Other network services are configured, such as SNMP dashboard polling and dashboard traps, syslog, SNMP device polling, and NetFlow.
7. Lastly, Adaptive Policy is configured, and ThousandEyes, Splunk, and XDR are integrated with the Meraki Dashboard.

Name the devices and set the location

By default, the MXs, switches, and AP devices are named by their mac-addresses. The switch names have already been modified during the onboarding steps.

Procedure 15. To give more user-friendly names and to configure their locations:

MXs: In this example, the primary is named B2-MX1 and the spare is named B2-MX2.

Step 1. Go to **Security & SD-WAN > Monitor > Appliance Status**.

Step 2. Click **edit** next to the mac address in the top left corner, and

Step 3. Enter the **Appliance name** (B2-MX1) then click **Save**.

Step 4. Next to **ADDRESS**, click **edit**, enter the street address or GPS coordinates of the location of the device, then click **Save**.

Step 5. Go to **Security & SD-WAN > Monitor > Spare Status** to name the spare MX (B2-MX2). There is no location option for the spare MX.

Switches:

Step 1. Go to **Switching > Monitor > Switches**.

Step 2. Select the switch name to view.

Step 3. Next to **ADDRESS**, click **edit**, enter the street address or GPS coordinates of the location of the device, then click **Save**.

Step 4. Repeat for the other switch.

AP:

Step 1. Go to **Wireless > Monitor > Access Points**.

Step 2. Select the AP mac address to view.

Step 3. In the top left corner next to the mac address, click **edit**.

Step 4. Enter the **Access Point name** (B2-AP1), then click **Save**.

Step 5. Next to **Address**, click **edit**.

Step 6. Enter the street address or GPS coordinates of the location of the device, then click **Save**.

B2-MX1
MX85 08:f1:b3:89:c5:1f
PRIMARY

Cisco Systems - Building 5
7025 Kit Creek Road, RTP, NC 27709
PRIMARY
Current master

Ports

USB Management WAN
SFP GbE
1 3
2 4

Historical device data

Connectivity
12:00

Network-wide: Configure time zone

Time zone is used for time-sensitive features such as SSID Availability or Port Scheduling. In this example, it is used to set the schedule for SSID availability and for event logging.

In this example, America - New York (UTC -5.0) is selected.

Regulatory domain	FCC
Regulatory info	<input type="button" value="Download regulatory file"/>
Local time zone	<input type="button" value="America - New York (UTC ... ▼)"/>

Procedure 16. To configure a time zone:

Step 1. Go to **Network-wide > Configure > General**.

Step 2. Next to **Local time zone**, from the drop-down menu, if it's not already configured, select the appropriate time zone.

Step 3. Click **Save** or **Save Changes**.

Network-wide: Configure traffic analysis settings

In this section, hostname visibility is enabled under Traffic Analysis settings. Activating hostname visibility provides detailed statistical insights into the hostnames and IP addresses accessed by clients across the network. When configured, the menu item **Network-wide > Monitor > Traffic Analytics** appears in the dashboard. Information can also be accessed under **Network-wide > Monitor > Clients**.

Traffic analysis	
Traffic analysis	<input type="button" value="Detailed: collect destination hostnames ▼"/>
Custom pie chart	No slices specified. Add a slice

Procedure 17. To activate hostname visibility:

Step 1. Go to **Network-wide > Configure > General**.

Step 2. From the drop-down menu under **Traffic analysis**, select **Detailed: collect destination hostnames**.

Step 3. Click **Save** or **Save Changes**.

MX router: Configure warm spare uplink IP

By default, when the warm spare becomes active, it leverages its own WAN uplink IP addresses that were configured or received from DHCP from the transport provider. There is an option to use a virtual uplink IP address on each transport, so when the warm spare takes over, the same virtual IP address becomes active on the spare. The virtual IP addresses must be within the same subnet but must be distinct from the appliance WAN uplink IP addresses. This reduces traffic convergence time during a failover.

Procedure 18. To configure warm spare uplink IP address:

Step 1. Go to **Security & SD-WAN > Monitor > Appliance Status**. Next to **Spare**, click the **Edit** icon.

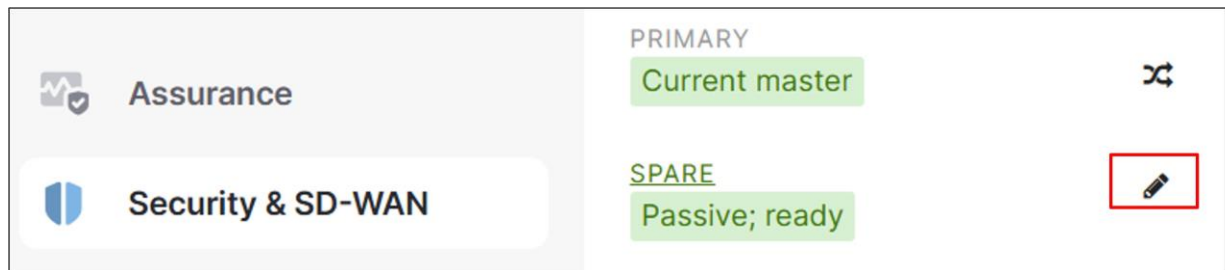

Step 2. Next to **Uplink IPs**, from the drop-down menu, select **Use virtual uplink IPs**.

Step 3. Next to **WAN 1 shared IP**, type in the virtual IP address for the first WAN transport.

Step 4. Next to **WAN 2 shared IP**, type in the virtual address for the second transport.

A screenshot of the 'Configure warm spare' dialog box. It has a title bar with a close button. The main content area contains several fields: 'Warm spare' with 'Enabled' and 'Disabled' buttons; 'Device serial' with a dropdown menu showing 'Q2YN-RWA7-RVDK'; 'MAC address' with the value '08:f1:b3:89:ca:47'; 'Model' with the value 'MX85'; 'Uplink IPs' with a dropdown menu showing 'Use virtual uplink IPs'; 'WAN 1 shared IP' with a text input field containing 'X.X.X.X'; 'WAN 1 subnet' with an empty text input field; 'WAN 2 shared IP' with a text input field containing 'X.X.X.X'; and 'WAN 2 subnet' with an empty text input field. At the bottom right, there are 'Cancel' and 'Update' buttons, with the 'Update' button highlighted by a red box.

Step 5. Click **Update**.

MX router: Configure VLAN interfaces

Procedure 19. To configure VLAN interfaces:

Step 1. Under **Security & SD-WAN > Configure > Addressing & VLANs > Routing > LAN setting**, select **VLANs**. VLAN 1 is automatically created with a VLAN interface IP of 192.168.128.1/24.

Step 2. In the **Subnets** section, click **Add VLAN**. Enter **VLAN name** (DATA) and **VLAN ID** (10).

Step 3. Next to **VLAN interface IP**, enter the IP address of the MX gateway address for VLAN 10 (DATA) (10.10.2.1).

This is in the form 10.<VLAN#><SITE#>.1 so global firewall rules for site-to-site VPNs can be efficiently applied.

Step 4. Next to **Subnet**, enter the VLAN subnet (10.10.2.0/24), then click **Create**.

Step 5. Click **Save**, which may be at the bottom of the page.

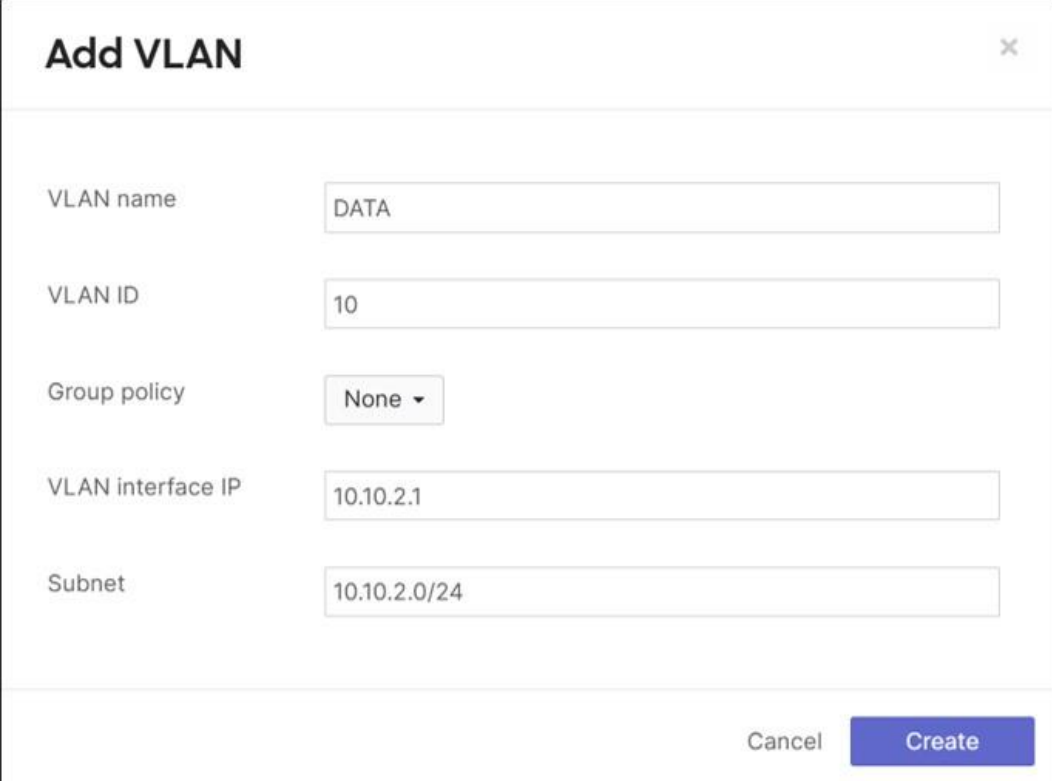

The screenshot shows a web form titled "Add VLAN" with a close button (X) in the top right corner. The form contains the following fields:

- VLAN name:** A text input field containing "DATA".
- VLAN ID:** A text input field containing "10".
- Group policy:** A dropdown menu with "None" selected.
- VLAN interface IP:** A text input field containing "10.10.2.1".
- Subnet:** A text input field containing "10.10.2.0/24".

At the bottom right of the form, there are two buttons: "Cancel" and "Create".

Step 6. Repeat the steps to add additional VLANs for 20 (VOICE), 30 (IOT), 40 (PCI), 50 (GUEST), and INFRA (999).

The VLAN 1 interface IP address is left at default (192.168.128.1) and the VLAN 999 (INFRA) interface IP address is configured as 10.250.<site#>.1. The VLANs 10, 20, 30, and 40 interface IPs follow the scheme 10.<VLAN#><Site#>.1. Site # in this example is 2. All subnets are /24 masks. All guest traffic on all branches shares the same subnet (172.16.99.0/24), and the GUEST VLAN interface IP address is configured for 172.16.99.1.

Routing

LAN setting VLANs Single LAN

Subnets ☰ Search by VLAN name, MX IF Delete Add VLAN

<input type="checkbox"/>	ID ▼	VLAN name	Subnet	VLAN interface IP	Group policy
<input type="checkbox"/>	999	INFRA	10.250.2.0/24	10.250.2.1	None
<input type="checkbox"/>	50	GUEST	172.16.99.0/24	172.16.99.1	None
<input type="checkbox"/>	40	PCI	10.40.2.0/24	10.40.2.1	None
<input type="checkbox"/>	30	IOT	10.30.2.0/24	10.30.2.1	None
<input type="checkbox"/>	20	VOICE	10.20.2.0/24	10.20.2.1	None
<input type="checkbox"/>	10	DATA	10.10.2.0/24	10.10.2.1	None
<input type="checkbox"/>	1	Default	192.168.128.0/24	192.168.128.1	None

7 results

Step 7. Click **Save**, which may be at the bottom of the page.

MX router: Modify unused ports

Procedure 20. To modify unused ports:

Step 1. Navigate to **Security & SD-WAN>Configure>Addressing & VLANs** under **Per-port VLAN Settings**.

Step 2. Select the unused ports (ports 7-14 in this case) and click **Edit**.

Step 3. Next to **Enabled**, from the drop-down menu, select **Disabled**.

Step 4. Click **Update**.

Configure MX LAN ports ✕

Enabled Disabled ▼

Cancel Update

Step 5. Click **Save**.

MX router: Modify VLANs allowed on trunks

Procedure 21. To modify VLANs allowed on trunks:

Step 1. Under the **Per-port VLAN Settings**, there are two trunk ports (ports 5 and 6), one to B2-SW1 and one to B2-SW2. Select **ports 5 and 6** and click **Edit**.

Step 2. Next to **Allowed VLANs**, delete **All VLANs** or **Existing Values**.

Step 3. From the drop-down menu, select **VLAN 1 (Default)**, **VLAN 10 (DATA)**, **VLAN 20 (VOICE)**, **VLAN 30 (IOT)**, **VLAN 40 (PCI)**, **VLAN 50 (GUEST)**, and **VLAN 999 (INFRA)**, then click **Update**.

The screenshot shows a configuration window titled "Configure MX LAN ports". It has several settings:

- Enabled:** A dropdown menu currently showing "Enabled".
- Type:** A dropdown menu currently showing "Trunk".
- Native VLAN:** A dropdown menu currently showing "VLAN 1 (Default)".
- Allowed VLANs:** A list of selected VLANs, each with a small 'x' icon to remove it. The selected VLANs are: VLAN 1 (Default), VLAN 10 (DATA), VLAN 20 (VOICE), VLAN 30 (IOT), VLAN 40 (PCI), VLAN 50 (GUEST), and VLAN 999 (INFRA). There is a small 'x' icon and a dropdown arrow at the end of the list.

At the bottom right of the window, there are two buttons: "Cancel" and "Update". The "Update" button is highlighted with a red rectangular box.

Step 4. Click **Save**.

MX router: Configure DHCP

By default, All DHCP pools are local and proxy to an upstream DNS, which is out on the Internet transport.

In this network, the Default, INFRA, and GUEST VLANs use local DHCP pools, while the other subnets use DHCP services in the data center. INFRA devices use reserved IP addresses from the DHCP pool. Only GUEST and Default VLANs should use an Internet DNS server (OpenDNS), while everything else uses DNS services in the data center.

Tech tip: For MS switch stacks (except for MS390), each stack member receives its own IP address using its burned-in mac address (**Switching > Monitor > Switches > MAC address**). For Catalyst switch stacks running CS code and the MS390, each stack member shares a single IP address with the active member, and the stack leverages the burned-in mac address of the active member that is persistent when a new member takes over. For Catalyst switch stacks running IOS XE code, each stack member also shares a single IP address with the active member, but the stack leverages a single virtual mac address of the form, 00:18:0a:4f:00:XX. To find the mac address used for switch

stack management, go to **Security & SD-WAN > Monitor > Appliance Status**. Click the **DHCP** tab and search for the device which should have received an IP address in VLAN 1.

Ideally, management IP addresses should be statically configured and their addresses excluded from the DHCP pool. Due to limitations in automation at this time, DHCP has to be leveraged for IP assignment. Fixed IP address assignments in the DHCP pool allow devices to use DHCP to get an address but ensure those devices get the same IP address each time. A device mac address is needed for the configuration.

Because IOS XE switch stacks use a virtual mac address, a new mac address could potentially be generated on complete power down and power back up of the entire switch stack (depending on what might be going on with other IOS XE switch stacks in the network at the time). The algorithm ensures that no other network devices share the same virtual mac address. If the mac address changes, the switch stack will receive a new management IP address from the DHCP pool instead of the one that was initially assigned.

Before configuring this section, gather the mac addresses from any access points and all switches and switch stacks so fixed IP address assignments can be created.

Device	Dashboard location	Mac address
B2-SW1	Switching>Monitor>Switches>MAC address	6c:c3:b2:7f:a7:40
B2-SW2	Switching>Monitor>Switches>MAC address	5c:06:10:5f:67:2e
B2-AP1	Wireless>Monitor>Access Points>MAC address	cc:6e:2a:d8:9b:10

Procedure 2
to configure
DHCP:

Step 1. G
o to
Securit
Specify

y & SD-WAN > Configure > DHCP and under **VLAN 999 (INFRA)** next to **DNS nameservers**, select **Specify nameservers**.

Step 2. Next to **Custom nameservers**, type in the DNS servers at the data center (10.102.1.160 and 10.102.1.161 in this example).

VLAN 999 (INFRA) 4 10.250.2.0/24 ⓘ

Client addressing ⓘ Run a DHCP server ▾

Mandatory DHCP ⓘ Disabled ▾

Lease time ⓘ 1 day ▾

DNS nameservers ⓘ Specify nameservers... ▾
For DHCP responses

Custom nameservers
10.102.1.160
10.102.1.161

Boot options ⓘ Boot options disabled ▾

Step 3. Next to **Fixed IP assignments**, click **Add a fixed IP assignment**.

Step 4. Enter a name for the device, the mac address, and what LAN IP address is to be assigned.

Step 5. Repeat for all devices.

Boot options ⓘ

Boot next-server ⓘ

Boot filename ⓘ

DHCP options ⓘ There are no special DHCP options on this DHCP section.
[Add a DHCP option](#)

Reserved IP ranges ⓘ There are no reserved IP address ranges on this DHCP section.
[Add a reserved IP address range](#)
[Import CSV](#)

Fixed IP assignments ⓘ

Client name	MAC address	LAN IP	Actions
<input type="text" value="B2-SW1"/>	<input type="text" value="6c:c3:b2:7f:a7:40"/>	<input type="text" value="10.250.2.11"/>	<input type="text" value="✕"/>
<input type="text" value="B2-SW2"/>	<input type="text" value="5c:06:10:5f:67:2e"/>	<input type="text" value="10.250.2.12"/>	<input type="text" value="✕"/>
<input type="text" value="B2-AP1"/>	<input type="text" value="cc:6e:2a:d8:9b:10"/>	<input type="text" value="10.250.2.21"/>	<input type="text" value="✕"/>

[Add a fixed IP assignment](#)
[Import CSV](#)

Step 6. Click **Save Changes** at the bottom of the page.

Step 7. For VLANs 10, 20, 30, and 40, next to **Client addressing**, select **Relay DHCP to another server** and next to **DHCP server IPs**, type in the data center DHCP servers (10.102.1.160 and 10.102.1.161 in this example).

Step 8. Click **Save** or **Save Changes**.

VLAN 10 (DATA) ◆ 4 10.10.2.0/24 ⓘ

Client addressing ⓘ

DHCP server IPs ⓘ

Mandatory DHCP ⓘ

Tech tip: The DHCP relay IP address must be in a subnet connected to the network or on a subnet reachable through the site-to-site VPN (not through the default route). In the example data center, there is a static route defined to reach the DC services network, and that static route is in VPN mode so it can be advertised to other Auto VPN members.

Step 9. For the GUEST VLAN (50) and Default VLAN (1), next to **Mandatory DHCP**, from the drop-down menu, select **Enabled**.

Step 10. Next to **DNS nameservers**, from the drop-down menu, select **Use OpenDNS**.

Step 11. Click **Save** or **Save Changes**.

VLAN 50 (GUEST) 4 172.16.99.0/24 i

Client addressing i Run a DHCP server v

Mandatory DHCP i Enabled v

Lease time i 1 day v

DNS nameservers i Use OpenDNS v
For DHCP responses

Boot options i Boot options disabled v

MX router: Configure site-to-site VPNs

Hub and spoke settings

Procedure 23. To configure hub and spoke settings:

- Step 1.** Under **Security & SD-WAN > Configure > Site-to-site VPN**, next to **Type**, select **Spoke**.
- Step 2.** Next to **Hubs**, click **Add a hub** and select the primary hub (RTP6-DC1 in this example).
- Step 3.** Click **Add a hub** and select the secondary hub (RTP6-DC2 in this example). Since DC1 was selected first, this prioritizes DC1 as the primary hub, so if routes are equal, DC1 is selected to route the traffic.
- Step 4.** Click **Save** or **Save Changes**.

Site-to-site VPN

Type i

Off
Do not participate in site-to-site VPN.

Hub (Mesh)
Establish VPN tunnels with all hubs and dependent spokes.

Spoke
Establish VPN tunnels with selected hubs.

Hubs i

#	Name	IPv4 default route	Actions
1	RTP6-DC1 v	<input type="checkbox"/>	☰ ✕
2	RTP6-DC2 v	<input type="checkbox"/>	☰ ✕

VPN settings for VLANs

By default, subnets are not advertised to other sites through the VPN registry.

Procedure 24. To configure VPN settings for VLANs:

- Step 1.** Under **Security & SD-WAN > Configure > Site-to-site VPN**, under **VPN settings > Local networks**, choose **Enabled** under **VPN mode** for DATA, VOICE, IOT, PCI, and INFRA so these networks can be advertised.

Step 2. Click **Save** or **Save Changes**.

VPN settings			
Local networks	Name	VPN mode	Subnet
	Default	Disabled ▾	192.168.128.0/24
	DATA	Enabled ▾	10.10.2.0/24
	VOICE	Enabled ▾	10.20.2.0/24
	IOT	Enabled ▾	10.30.2.0/24
	PCI	Enabled ▾	10.40.2.0/24
	GUEST	Disabled ▾	172.16.99.0/24
	INFRA	Enabled ▾	10.250.2.0/24

MX router: Configure firewall rules

VPN site-to-site outbound firewall

The VPN site-to-site outbound firewall rules apply to outbound VPN traffic destined to other VPN-connected sites and is applied at an organization level, meaning, these same rules apply to every MX router in the organization with site-to-site VPN enabled. This is important as it influences the way the rules should be crafted. In the example network, the network scheme is 10.<vlan#><site#>.0/24 so firewall rules can be applied more easily at the organizational level. The Data VLAN across the organization is represented by the subnet 10.10.0.0/16 instead of a list of disjointed 10.x networks.

If the policy objects and VPN site-to-site outbound firewall policy are already defined, go to [Local firewall](#).

For the VPN site-to-site outbound firewall rules, only policy objects, policy object groups, IPv4/IPv6 addresses, or subnets can be referenced. The following policy is implemented:

- Allow the DATA, VOICE, IOT, PCI, and INFRA subnets in any branch to reach Corporate shared services (DHCP, DNS, RADIUS, SNMP, and Management) and allow Corporate shared services to reach the DATA, VOICE, IOT, PCI, and INFRA subnets in any branch.
- Deny access from DATA, VOICE, IOT, PCI, and INFRA subnets to other subnets in other sites. Meaning, DATA subnets cannot reach VOICE, IOT, PCI, and INFRA subnets, and so on.
- Allow everything else. This is the default rule and allows DATA subnets to reach other DATA subnets as well as other routes through the hub. VOICE subnets can reach other VOICE subnets as well as other routes through the hub, and so on.

Note: Guest and Default traffic do not traverse the VPN overlay due to VPN mode being disabled for these VLANs. They can be included in the rule as “Deny GUEST subnet or Default subnet to Any” and “Deny Any to GUEST subnet or Default subnet” if needed, in the event the GUEST or Default VLAN’s VPN mode is enabled, and a unique subnet is configured.

Policy, or network, objects and groups provide easier management of firewall rules. They serve as labels for IP subnets, IP addresses, or FQDNs. Policy groups contain one or more IP/CIDR network objects or one or more FQDN network objects. When created, these objects and groups can be used in both side-to-site VPN outbound firewall rules as well as Layer 3 inbound/outbound firewall rules. Policy objects and groups are defined at the organization level.

Procedure 25. To configure policy objects and VPN site-to-site outbound firewall rules:

Step 1. Go to **Organization > Configure > Policy Objects**.

Step 2. Under the **All objects** tab, click **Add new**.

Step 3. Under **Name**, type in a name (Corp DNS-DHCP in this example) and under **FQDN, IP or CIDR**, add an IP host (10.102.1.160 in this example), then click **Create object**.

Step 4. After the objects are created, go to the **Groups** tab to create a grouping. In this example, a Corp Shared Services group is created for the various network services sitting in the data center.

Note: Objects within policy groups can be created before the policy group object is created or while the policy group object is being defined.

Step 5. Create these objects and object group. GUEST and Default subnet is leveraged by the layer 3 local firewall rules in a subsequent section.

Object or Object Group	Name	Category	FQDN, IP, or CIDR
Object	Corp DNS-DHCP	Network	10.102.1.160

Object or Object Group	Name	Category	FQDN, IP, or CIDR
Object	Corp Mgt	Network	10.102.1.160
Object	Corp SNMP	Network	10.102.1.161
Object	Corp RADIUS	Network	10.102.1.157
Object	DATA Subnet	Network	10.10.0.0/16
Object	Default Subnet	Network	192.168.128.0/24
Object	GUEST Subnet	Network	172.16.99.0/24
Object	INFRA Subnet	Network	10.250.0.0/16
Object	IOT Subnet	Network	10.30.0.0/16
Object	PCI Subnet	Network	10.40.0.0/16
Object	VOICE Subnet	Network	10.20.0.0/16
Object Group	Corp Shared Services	--	Corp DNS-DHCP/Corp Mgt/Corp SNMP/Corp RADIUS

Step 6. Go to **Security & SD-WAN > Configure > Site-to-Site VPN**, and under **Site-to-site outbound firewall**, configure these settings:

Policy	Rule description	Protocol	Source	Src port	Destination	Dst port
Allow	Shared Services	Any	DATA Subnet/VOICE Subnet/IOT Subnet/PCI Subnet/INFRA Subnet (Objects)	Any	Corp Shared Services (Object group)	Any
Allow	Shared Services	Any	Corp Shared Services (Object group)	Any	DATA Subnet/VOICE Subnet/IOT Subnet/PCI Subnet/INFRA Subnet (Objects)	Any
Deny	Data Access	Any	DATA Subnet (Object)	Any	VOICE Subnet/PCI Subnet/IOT Subnet/INFRA Subnet (Objects)	Any
Deny	Voice Access	Any	VOICE Subnet (Object)	Any	DATA Subnet/IOT Subnet/PCI Subnet/INFRA Subnet (Objects)	Any
Deny	IOT Access	Any	IOT Subnet (Object)	Any	DATA Subnet/VOICE Subnet/PCI Subnet/INFRA Subnet (Objects)	Any
Deny	PCI Access	Any	PCI Subnet (Object)	Any	DATA Subnet/VOICE Subnet/IOT Subnet/INFRA Subnet (Objects)	Any
Deny	Infra Access	Any	INFRA Subnet (Object)	Any	DATA Subnet/VOICE Subnet/IOT Subnet/PCI Subnet (Objects)	Any
Allow	Default Rule	Any	Any	Any	Any	Any

Step 7. Click **Finish editing**.

Step 8. Click **Save Changes**.

#	Policy	Rule description	Protocol	Source	Src port	Destination	Dst port	Syslog	Enforce	Actions
1	Allow	Shared Services	Any	DATA Subnet, IOT Subnet, VOICE Subnet, INFRA Subnet, PCI Subnet	Any	Corp Shared Services	Any	<input type="checkbox"/>	<input checked="" type="checkbox"/>	...
2	Allow	Shared Services	Any	Corp Shared Services	Any	DATA Subnet, IOT Subnet, VOICE Subnet, INFRA Subnet, PCI Subnet	Any	<input type="checkbox"/>	<input checked="" type="checkbox"/>	...
3	Deny	Data Access	Any	DATA Subnet	Any	IOT Subnet, VOICE Subnet, INFRA Subnet, PCI Subnet	Any	<input type="checkbox"/>	<input checked="" type="checkbox"/>	...
4	Deny	Voice Access	Any	VOICE Subnet	Any	IOT Subnet, INFRA Subnet, DATA Subnet, PCI Subnet	Any	<input type="checkbox"/>	<input checked="" type="checkbox"/>	...
5	Deny	IOT Access	Any	IOT Subnet	Any	DATA Subnet, INFRA Subnet, VOICE Subnet, PCI Subnet	Any	<input type="checkbox"/>	<input checked="" type="checkbox"/>	...

Local firewall

Local firewall rules apply to LAN traffic as well as direct Internet traffic. It does not apply to VPN site-to-site traffic.

Tech tip: VLAN objects can be leveraged automatically in local firewall rules in single MX deployments but are not available to use in VPN site-to-site outbound firewall rules.

VLAN objects used in firewall rules are not compatible with the MX warm spare feature. If VLAN objects are used in firewall rules and an MX warm spare is added to the network, any existing layer 3 rules referencing VLAN objects are removed.

The layer 3 policy will leverage the policy objects created for the VPN site-to-site outbound firewall rules. These policy objects can be leveraged at all branches. The following policy is implemented.

- Allow the Data subnet to access local Printers (10.30.2.101 and 10.30.2.102) on the IOT subnet. The Layer 3 firewall rules are stateful, so traffic in the opposite direction is allowed back through.
- Deny access from Default, DATA, VOICE, IOT, PCI, GUEST, and INFRA subnets to other subnets at the same site. Meaning, DATA subnets cannot reach Default, VOICE, IOT, PCI, GUEST, and INFRA subnets, and so on.
- Allow direct Internet access (DIA) for Default, INFRA, DATA, and GUEST subnets. Default and GUEST subnet traffic strictly uses DIA. For the INFRA subnet, dashboard traffic for devices behind the MX uses DIA. For the DATA subnet, Webex and Office 365 traffic uses DIA while the rest of the DATA subnet traffic leverages Cisco Secure Access for Internet traffic.
- Deny everything else. This does not affect VPN site-to-site traffic, which is governed by site-to-site VPN firewall rules. This means that VOICE, IOT, and PCI subnets will be denied DIA.

Tech tip: When a default route is configured from the hub router or through Cisco Secure Access (as in this example), the MX is in full tunnel mode. In order for DIA to occur, VPN exclusions identifying traffic to be broken out must be configured (shown later in this example, under **Security & SD-WAN > Configure > SD-WAN & Traffic Shaping**). When broken out for DIA, this traffic is subjected to local firewall rules. These rules do not affect traffic going to Cisco Secure Access. VPN exclusions are configured based on IP destination or application. It is important to design the firewall rules carefully so they are not more restrictive than the defined VPN exclusions (unless that is needed), as this could unexpectedly blackhole traffic. For example, excluding ICMP with a destination of 8.8.8.8 sends all ICMP traffic regardless of the source VLAN with a destination of 8.8.8.8 to DIA. If the firewall blocks IOT traffic from DIA, ICMP traffic to 8.8.8.8 from the IOT VLAN is dropped. If this traffic should go to Cisco Secure Access, ensure it is not configured in VPN exclusions.

Policy objects and a group can be optionally created for the branch printers.

Procedure 26. To configure policy objects and configure local firewall rules:

Step 1. Create these objects and group under **Organization > Configure > Policy Objects**:

Object or Object Group	Name	Category	FQDN, IP, or CIDR
Object	Branch 2 Printer 1	Network	10.30.2.101
Object	Branch 2 Printer 2	Network	10.30.2.102
Object Group	Branch 2 Printers	---	Branch 2 Printer 1/Branch 2 Printer 2

Step 2. Select **Security & SD-WAN > Configure > Firewall** and under **Layer 3 > Outbound rules**, click **Add new**.

Step 3. Fill out the parameters and click **Add new** to add the next rule as shown in this table:

Policy	Rule Description	Protocol	Source	Src port	Destination	Dst Port
Allow	Local Print Access	Any	DATA Subnet (Object)	Any	Branch 1 Printers (Object group)	Any
Deny	Default (VLAN 1) Access	Any	Default Subnet (Object)	Any	DATA Subnet/VOICE Subnet/IOT Subnet/PCI Subnet/GUEST Subnet/INFRA Subnet (Objects)	
Deny	Data Access	Any	DATA Subnet (Object)	Any	Default Subnet/VOICE Subnet/IOT Subnet/PCI Subnet/GUEST Subnet/INFRA Subnet (Objects)	Any
Deny	Voice Access	Any	VOICE Subnet (Object)	Any	Default Subnet/DATA Subnet/IOT Subnet/PCI Subnet/GUEST Subnet/INFRA Subnet (Objects)	Any
Deny	IOT Access	Any	IOT Subnet (Object)	Any	Default Subnet/DATA Subnet/VOICE Subnet/PCI Subnet/GUEST Subnet/INFRA Subnet (Objects)	Any
Deny	PCI Access	Any	PCI Subnet (Object)	Any	Default Subnet/DATA Subnet/VOICE Subnet/IOT Subnet/GUEST Subnet/INFRA Subnet (Objects)	Any
Deny	Guest Access	Any	GUEST Subnet (Object)	Any	Default Subnet/DATA Subnet/VOICE Subnet/IOT Subnet/PCI Subnet/INFRA Subnet (Objects)	

Policy	Rule Description	Protocol	Source	Src port	Destination	Dst Port
Deny	Infra Access	Any	INFRA Subnet (Object)	Any	Default Subnet/DATA Subnet/VOICE Subnet/IOT Subnet/PCI Subnet/GUEST Subnet (Objects)	
Allow	Allow Direct Internet Access	Any	Default Subnet (Object)/INFRA Subnet (Object)/DATA Subnet (Object)/GUEST Subnet (Object)	Any	Any	Any
Deny	Deny All	Any	Any	Any	Any	Any
Allow	Default rule	Any	Any	Any	Any	Any

Step 4. When complete, click **Finish editing**, then **Save** or **Save Changes**.

#	Policy	Rule description	Protocol	Source	Src port	Destination	Dst port
1	Allow	Local Print Access	Any	DATA Subnet	Any	Branch 1 Printers	Any
2	Deny	Default (VLAN 1) Access	Any	Default Subnet	Any	DATA Subnet VOICE Subnet IOT Subnet PCI Subnet GUEST Subnet INFRA Subnet	Any
3	Deny	Data Access	Any	DATA Subnet	Any	Default Subnet VOICE Subnet IOT Subnet PCI Subnet GUEST Subnet INFRA Subnet	Any
4	Deny	Voice Access	Any	VOICE Subnet	Any	Default Subnet DATA Subnet IOT Subnet PCI Subnet GUEST Subnet INFRA Subnet	Any
5	Deny	IoT Access	Any	IOT Subnet	Any	Default Subnet DATA Subnet VOICE Subnet PCI Subnet GUEST Subnet INFRA Subnet	Any
6	Deny	PCI Access	Any	PCI Subnet	Any	Default Subnet DATA Subnet VOICE Subnet IOT Subnet GUEST Subnet INFRA Subnet	Any
7	Deny	Guest Access	Any	GUEST Subnet	Any	Default Subnet DATA Subnet VOICE Subnet IOT Subnet PCI Subnet INFRA Subnet	Any
8	Deny	Infra Access	Any	INFRA Subnet	Any	Default Subnet DATA Subnet VOICE Subnet IOT Subnet PCI Subnet GUEST Subnet	Any
9	Allow	Allow Direct Internet Access	Any	Default Subnet INFRA Subnet DATA Subnet GUEST Subnet	Any	Any	Any
10	Deny	Deny All	Any	Any	Any	Any	Any
	Allow	Default rule	Any	Any	Any	Any	Any

Cisco Secure Access and MX router: Configure secure internet access tunnels

Secure tunnels are configured with Cisco Secure access and the MX router for branch direct Internet access.

Note: When the tunnels are set up in the Meraki Dashboard to a particular network tunnel group in Cisco Secure Access, the configurations are available in the Meraki Dashboard at the organizational level for other branches to leverage. To leverage an existing secure tunnel pair, the branch is tagged in the **Organization > Monitor > Overview** page using the same tag attached to the IPsec tunnel pair when created (SSE_East in this example). No additional configuration is required.

These steps show how to tag a branch to leverage a Cisco Secure Access tunnel pair, set up a network tunnel group in Cisco Secure Access and subsequently, configure the primary and secondary IPsec tunnel pairs in the Meraki Dashboard to connect to that network tunnel group if not already configured.

If Cisco Secure Access tunnels pairs are already set up, configure the network tag for the preferred branch and skip the tunnel configuration in Cisco Secure Access and on the MX router.

Organization level: Tag the branch to leverage Cisco Secure Access tunnels

In this example, a tag called “SSE_East” is selected/created in the Dashboard to reference an active/standby tunnel pair that exists or will be configured, connecting Branch 2 to Cisco Secure Access.

Procedure 27. To tag the branch to leverage Cisco Secure Access tunnels:

Step 1. On the Meraki Dashboard, navigate to **Organization > Monitor > Overview**.

Step 2. Select the branch network (RTP6-Branch2) then click **Tag**.

		Networks			
<input type="checkbox"/>	<input type="button" value="Tag"/>	<input type="button" value="Split networks"/>	<input type="button" value="Delete"/>	<input type="text" value="Search..."/>	10 networks Over the last week: 109 c
<input type="checkbox"/>		Name ▲	Usage	Clients	
<input type="checkbox"/>	<input type="checkbox"/>	RTP6-Branch1	820.6 MB	11	
<input type="checkbox"/>	<input type="checkbox"/>	RTP6-Branch11	579.6 MB	7	
<input type="checkbox"/>	<input type="checkbox"/>	RTP6-Branch13	2.20 GB	3	
<input checked="" type="checkbox"/>	<input type="checkbox"/>	RTP6-Branch2	8.29 GB	52	

Step 3. In the text box, select the existing tag, SSE_East, then click **Add**.

If the tag has not been created yet, type in the new tag (SSE_East), click **Add option** beneath the text box, then click **Add**.

		Networks		Network tags	
<input type="checkbox"/>	<input type="button" value="Tag"/>	<input type="button" value="Split networks"/>	<input type="button" value="Delete"/>	<input type="text" value="Search..."/>	9 networks Over the last week:
Add:		<input type="text" value="SSE_East"/>	<input type="button" value="Add"/>	Usage	Clients
		No results match SSE_East		2.97 GB	40
		<input type="button" value='Add option: "SSE_East"'/>		11.51 GB	36
				840.5 MB	4
				40.46 GB	52

Branch 2 now has an SSE_East tag.

Networks						Network tags
Tag ▾	Split networks ▾	Delete	Search... ▾	10 networks	Over the last week: 109 clients, 14.35 GB	
<input type="checkbox"/>		Name ▲	Usage	Clients	Tags	Network type
<input type="checkbox"/>		RTP6-Branch1	820.6 MB	11	SSE_East	Combined
<input type="checkbox"/>		RTP6-Branch11	579.6 MB	7		Combined
<input type="checkbox"/>		RTP6-Branch13	2.20 GB	3		Combined
<input checked="" type="checkbox"/>		RTP6-Branch2	8.29 GB	52	SSE_East	Combined

Step 4. If SSE tunnels are already configured, skip to the [Validate Status of Cisco Secure Access Tunnels](#) section to check the tunnel status.

Cisco Secure Access: Tunnel configuration

Procedure 28. To configure a Network Tunnel Group on Cisco Secure Access:

Step 1. Go to <https://sse.cisco.com> and log in with the proper credentials.

Step 2. From Cisco Secure Access, go to **Connect > Network Connections > Network Tunnel Groups** tab.

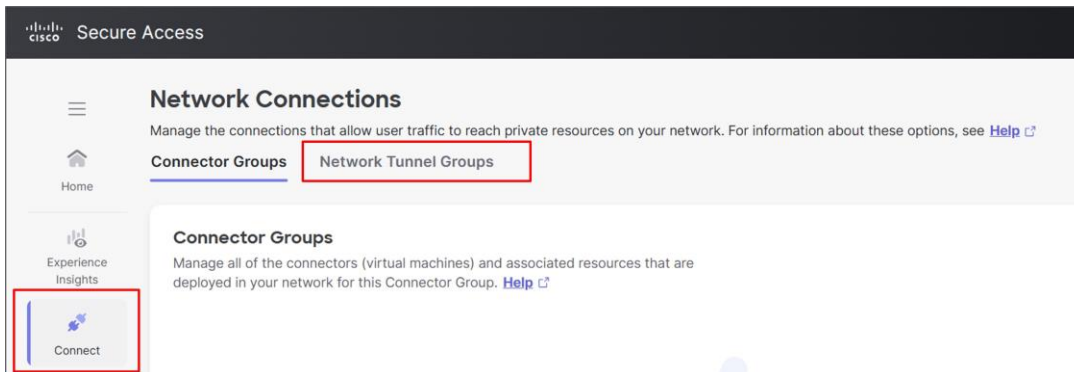

Step 3. Click **+ Add** to add a new tunnel group.

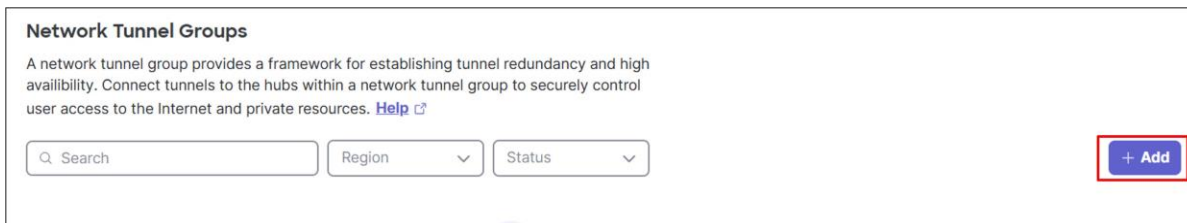

Step 4. Type in a meaningful **Tunnel Group Name** (UnifiedBranchEast), choose a **Region** (US (Virginia) in this example), and choose a **Device Type** (Meraki MX).

Step 5. Click **Next**.

General Settings

Give your network tunnel group a good meaningful name, choose a region through which it will connect to Secure Access, and choose the device type this tunnel group will use.

Tunnel Group Name

Region

Device Type

[Cancel](#) [Next](#)

Step 6. Configure a **Tunnel ID** and **Passphrase**.

Step 7. Enter the passphrase again under **Confirm Passphrase**. The Tunnel ID is a unique identifier and paired with the pre-shared key, allows a tunnel on the router to authenticate to the Secure Access headend.

Step 8. Click **Next**.

Tunnel ID and Passphrase

Configure the tunnel ID and passphrase that devices will use to connect to this tunnel group.

Tunnel ID
 @<org><hub>.sse.cisco.com

Passphrase
 [Show](#)

The passphrase must be between 16 and 64 characters long. It must include at least one upper case letter, one lower case letter, one number, and cannot include any special characters.

Confirm Passphrase
 [Show](#)

[Cancel](#) [Back](#) [Next](#)

Step 9. Under **Routing options and network overlaps > Network subnet overlap**, select the **Enable NAT / Outbound** only option.

Step 10. Click **Save**.

Routing options and network overlaps
Configure routing options for this tunnel group.

Network subnet overlap

Enable NAT / Outbound only

Routing options are unavailable when the network will contain overlapping subnets.
Network Address Translation will be applied to ensure correct routing and identification. When this option is selected, the tunnel group will be **outbound only** and cannot be used to provide access to private applications hosted at this site.

Internet Protocol Version Setting for Routing

Enable IPv6 Routing in addition to IPv4
IPv4 is enabled by default.

Routing option

Static routing
Use this option to manually add IP address ranges for this tunnel group.

Dynamic routing
Use this option when you have a BGP peer for your on-premise router.

Advanced Settings

Cancel Back Save

Step 11. On the **Data for Tunnel Setup** page, review the information.

Step 12. Click **Download CSV** to save the Tunnel ID and Data Center IP address information to use when setting up the tunnels on the network devices.

Step 13. Remember or copy the passphrase for safe keeping. It will not download in the CSV file, and it won't be viewable in the tunnel setup information.

Step 14. Click **Done**.

Data for Tunnel Setup
Review and save the following information for use when setting up your network tunnel devices. This is the only time that your passphrase is displayed.

Primary Tunnel ID: UnifiedBranchEast@[redacted]-sse.cisco.com

Primary Data Center IP Address: [redacted] [redacted]

Secondary Tunnel ID: UnifiedBranchEast@[redacted]-sse.cisco.com

Secondary Data Center IP Address: [redacted] [redacted]

Passphrase: [redacted]

Download CSV

Done

The status is shown for the tunnel, but it shows a disconnected status until the tunnels are established from the router.

Network Connections

Manage the connections that allow user traffic to reach private resources on your network. For information about these options, see [Help](#).

Connector Groups **Network Tunnel Groups**

Network Tunnel Groups 1 total

1

Disconnected

0

Warning

0

Connected

Network Tunnel Groups

A network tunnel group provides a framework for establishing tunnel redundancy and high availability. Connect tunnels to the hubs within a network tunnel group to securely control user access to the Internet and private resources. [Help](#)

Q Search

Region

Status

1 Tunnel Group

+ Add

Network Tunnel Group	Status	Region	Primary Hub Data Center	Primary Tunnels	Secondary Hub Data Center	Secondary Tunnels	
UnifiedBranchEast Meraki MX	✖ Disconnected	US (Virginia)	sse-use-1-1-0	0	sse-use-1-1-1	0	...

MX router: Cisco Secure Access tunnel configuration

In this section, an active/standby tunnel pair is configured to connect Branch 2 to the Cisco Secure Access tunnel group that was configured in the previous section.

Procedure 29. To add the primary tunnel:

- Step 1.** Select a branch already configured with site-to-site VPN tunnels (RTP-Branch2).
- Step 2.** Navigate to **Security & SD-WAN > Site-to-site VPN**.
- Step 3.** Under **Organization-wide settings > IPsec VPN Peers**, click **Configure health checks**.

Organization-wide settings

Options in this section apply to all VPN peers in this organization.

FQDN peering requires firmware 18.1 or higher. IPv6 peering requires firmware 18.2 or higher. [See documentation for more details.](#)

IPsec VPN Peers ?

Q Search Filters 0 peers Configure health checks + Add a peer

#	Name	IKE version	IPsec policies	Public IP or Hostname	Local ID	Remote ID <small>?</small>	IPsec subnets	Health check	Preshared secret	Availability/Network <small>?</small>	
---	------	-------------	----------------	-----------------------	----------	----------------------------	---------------	--------------	------------------	---------------------------------------	--

- Step 4.** Click **+ Add health check**.
- Step 5.** Type the name for the **Health check** (SSE) and configure the **Endpoint URL** (<http://service.sig.umbrella.com>).
- Step 6.** Click **Done**.

Configure health checks

Configure your health checks to use for tunnel health. Health check will use this IP for probing when the MX is in passthrough mode. Only one health check per tunnel can be used.

[+ Add health check](#)

Health check	Endpoint	
SSE	http://service.sig.umbrella.com	 

Rows per page < >

[Cancel](#) [Done](#)

Step 7. Click **+ Add** a peer and configure these settings for the Primary Tunnel:

- **Name:** Unified_Branch_East_Primary
- **IKE version:** IKEv2
- **Peers**
 - **Public IP or Hostname:** <Primary Data Center IP Address from Cisco Secure Access>
 - **Local ID:** <Primary Tunnel Group ID from Cisco Secure Access>
 - **Shared Secret:** <Passphrase from Cisco Secure Access>
 - **Routing:** Static
 - **Private subnets:** 0.0.0.0/0
 - **Availability:** SSE_East
- **Multi-Uplink IPsec VPN:** Enable
- **Tunnel monitoring**
 - **Health check:** SSE
- **IPsec policy**
 - **Preset:** Umbrella

Step 8. Click **Add**. Click **Save** or **Save Changes**.

Add VPN Peer ✕

Name

IKE version

Peers ^

Public IP or Hostname

Local ID

Remote ID ⓘ

Shared secret
 [Show](#)

Routing
 Static Dynamic (BGP)

Private subnets ⓘ

Step 9. You may get a warning that VLAN subnets overlap with the default route that was just configured for SSE. IP traffic is routed to the smallest subnet/longest prefix that contains the IP address, and the SSE default route is used for traffic not matching anything else in the routing table. Click **Confirm Changes**.

Tech tip: Under **IPsec Policy**, the Umbrella **Preset** configures the following settings automatically:

- Phase 1/Encryption: AES 256
- Phase 1/Authentication: SHA1
- Phase 1/Diffie-Hellman group: 14
- Phase 1/Lifetime: 14400 sec
- Phase 2/Encryption: AES 256
- Phase 2/Authentication: SHA1
- Phase 2/PFS group: Off
- Phase 2/Lifetime: 3600 sec

Procedure 30. To add the secondary tunnel:

Step 1. To the far right of the defined tunnel, click ... under the gear column.

Step 2. Select **Add secondary peer**.

IPsec VPN Peers ⓘ

Q Search Filters 1 peer Configure health checks + Add a peer

#	Name	IKE version	IPsec policies	Public IP or Hostname	Local ID	Remote ID	IPsec subnets	
1	Unified_Branch_East_Primary	IKEv2	Umbrella	[Redacted]	UnifiedBranchEast@[Redacted]	—	0.0.0.0/0	...

1-1 of 1 Rows per page

Inbound firewall logging Enable Disable

Site-to-site outbound firewall

Search...

- Primary
 - Edit primary peer
 - Move to
 - Delete primary peer
- Secondary
 - + Add secondary peer

Step 3. At the top of the form, click **Inherit primary peer configurations** to fill out most of the fields for the secondary peer.

Add Secondary VPN Peer

Inherit primary peer configurations ⓘ

Name

Unified_Branch_East_Primary Secondary

Step 4. Modify these fields:

- **Name:** Unified_Branch_East_Secondary
- **Peers**
 - **Public IP or Hostname:** <Secondary Data Center IP Address from Cisco Secure Access>
 - **Local ID:** <Secondary Tunnel Group ID from Cisco Secure Access>

Step 5. Click **Add**. Click **Save** or **Save Changes**.

Step 6. You may get a warning that VLAN subnets overlap with the default route that was just configured for SSE. IP traffic is routed to the smallest subnet/longest prefix that contains the IP address, and the SSE default route is used for traffic not matching anything else in the routing table. Click **Confirm Changes**.

IPsec VPN Peers ⓘ

Q Search Filters 1 peer Configure health checks + Add a peer

#	Name	IKE version	IPsec policies	Public IP or Hostname	Local ID	Remote ID	IPsec subnets	
1	Unified_Branch_East_Primary Primary	IKEv2	Umbrella	[Redacted]	UnifiedBranchEast@[Redacted]	—		...
	Unified_Branch_East_Secondary Secondary	IKEv2	Umbrella	[Redacted]	UnifiedBranchEast@[Redacted]	—		...

Validate status of Cisco Secure Access tunnels

Procedure 31. To check the status of the tunnels on Cisco Secure Access:

Step 1. Go to **Connect > Network Connections** and click the **Network Tunnel Groups** tab.

Step 2. Find the Network Tunnel Group created.

Network Tunnel Groups

A network tunnel group provides a framework for establishing tunnel redundancy and high availability. Connect tunnels to the hubs within a network tunnel group to securely control user access to the Internet and private resources. [Help](#)

Region ▼

Status ▼

1 Tunnel Group
+ Add

Network Tunnel Group	Status	Region	Primary Hub Data Center	Primary Tunnels	Secondary Hub Data Center	Secondary Tunnels	
UnifiedBranchEast <small>Meraki MX</small>	Connected	US (Virginia)	sse-use-1-1-0	2	sse-use-1-1-1	2	...

Step 3. Click ... on the far right and choose **View Details** to see additional details about the connected tunnels.

Procedure 32. To check the status of the tunnels on the MX router:

Step 1. Go to **Organization > Monitor > VPN Status**.

Step 2. Select the network to view (RTP6-Branch2).

VPN Status for the last day ▼

Usage

Latency

50%
90%
☰

Networks

Status	Description	Usage ▼	Latency (50%)	Latency (90%)
●	RTP6-DC1	64.8 MB	5 ms	9 ms
●	RTP6-Branch1	54.7 MB	0 ms	0 ms
●	RTP6-DC2	27.7 MB	15 ms	19 ms
●	RTP6-Branch4	20.8 MB	0 ms	0 ms
●	RTP6-Branch2	7.9 MB	0 ms	0 ms

Step 3. Click the **2 IPsec peers** box to view the status of the Cisco Secure Access peers.

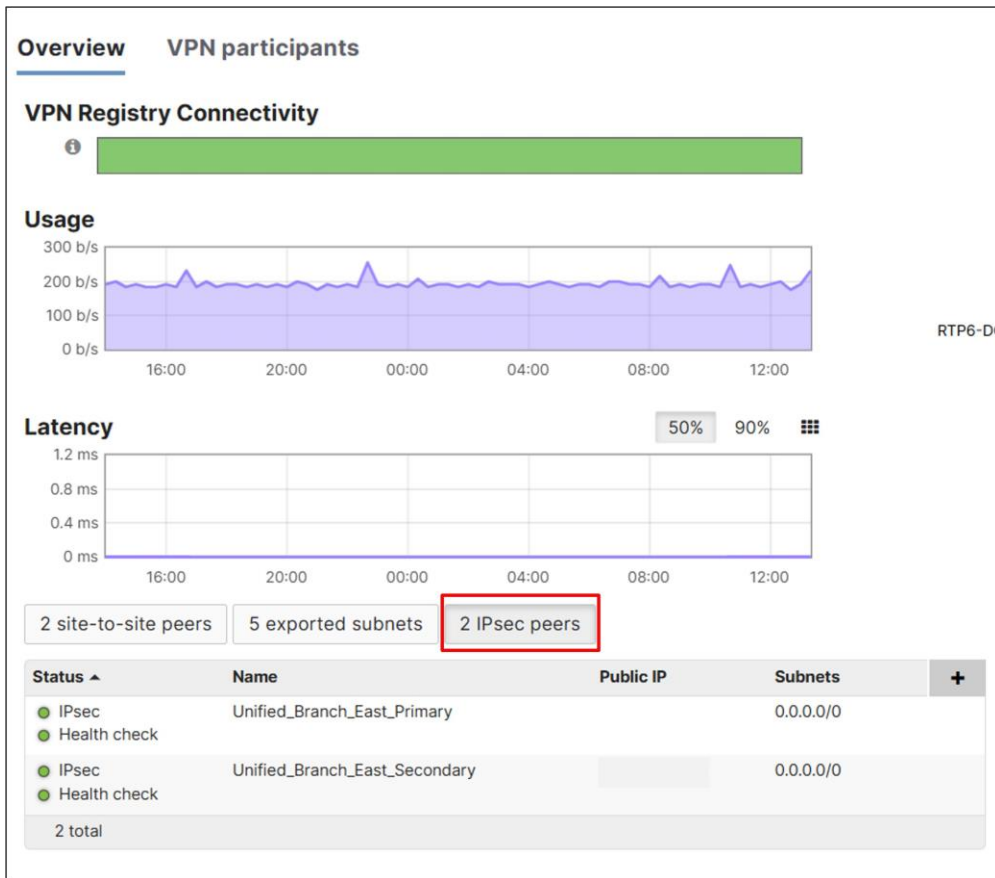

RTP6-DC

MX router: Configure SD-WAN & traffic shaping

In this example, most Internet traffic takes the Cisco Secure Access tunnels. The primary tunnels load balance automatically by default as long as they are going to the same data center. Guest traffic, Data/Corporate SaaS traffic (O365 and Webex), device (switch and AP) dashboard INFRA traffic, and Default traffic (if any) take direct Internet access (DIA) from the branch.

Uplink configuration

In this example, rate limiting is set on each WAN link to match the provider's service sub-line rate.

Procedure 33. To configure the WAN uplinks:

Step 1. Go to **Security & SD-WAN > Configure > SD-WAN & Traffic Shaping**.

Step 2. Under **Uplink configuration**, set **WAN 1** to 400 Mbps and **WAN 2** to 500 down (Mb/s) and 500 up (Mb/s) in this example.

SD-WAN & traffic shaping

Uplink configuration

WAN 1	400 Mbps	details
WAN 2	down (Mb/s) 500 up (Mb/s) 500	simple
Cellular	unlimited	details

Step 3. Under **Uplink selection>Global preferences**, the **Primary uplink** is kept as **WAN 1** (default), and **Load balancing** is disabled for direct Internet traffic. In addition, VPN tunnels are created over both available uplinks (**Multi-Uplink AutoVPN** is Enabled). Click **Save** or **Save Changes**.

Uplink selection

Global preferences

Primary uplink

WAN 1 ▼

WAN failover and
fallback behavior ⓘ

Graceful ▼

Load balancing

Enabled

Traffic will be spread across both uplinks in the proportions specified above.
Management traffic to the Meraki cloud will use the primary uplink.

Disabled

All Internet traffic will use the primary uplink unless overridden by an uplink preference or if the primary uplink fails.

Multi-Uplink AutoVPN

Enabled

Create VPN tunnels over all of the available uplinks (primary and secondary).

Disabled

Do not create VPN tunnels over the secondary uplink unless the primary uplink fails.

Local internet breakout

Because default routes are pointing to the Cisco Secure Access tunnels, the site is assumed to be in full-tunnel mode. This means that all Internet traffic is sent through the Cisco Secure Access tunnels. The exception is GUEST and Default VLAN traffic because their VPN mode is set to disabled and Internet access for these VLANs is allowed as a rule in the L3 firewall. To break out traffic for DIA, VPN exclusions first need to be configured. In this example, SaaS application (Office 365 and Webex) traffic from the DATA VLAN need to be broken out, as well as dashboard INFRA VLAN traffic for the infrastructure device control planes.

Note: Traffic generated from the MX itself cannot be subjected to local Internet breakout rules, but traffic from infrastructure devices and other clients behind the MX can. MX-generated management traffic takes the default route in the table, which is through the Cisco Secure Access tunnels.

Procedure 34. To break out traffic for DIA:

- Step 1.** Go to **Security & SD-WAN > Configure > SD-WAN & Traffic Shaping**.
- Step 2.** Under **Local internet breakout** next to **VPN exclusion rules**, click **Add +**.
- Step 3.** Select **Major applications** and choose **Office 365 Suite** and **Webex**.
- Step 4.** Under **Custom expressions**, specify the **Protocol**, **Destination** and click **Add**, then specify the **Dst port**, and click **Add expression**.
- Step 5.** Use these custom expressions to allow dashboard cloud communication and VPN registry traffic for devices behind the MX router. **Any** is used for the protocol to cover TCP, UDP, and ICMP traffic. **Any** is used for the destination port to cover multiple ports.

Alternatively, multiple custom expressions can be configured so specific protocols and ports can be used. Refer to [Upstream Firewall Rules for Cloud Connectivity](#) for latest, up-to-date port requirements for the dashboard.

Protocol	Destination	Dst port
UDP	64.62.142.12/32	Any
ANY	158.115.128.0/19	Any
ANY	209.206.48.0/20	Any
ANY	216.157.128.0/20	Any

- Step 6.** Click **Save** or **Save Changes**.



SD-WAN policies: Internet

In this part of the configuration, traffic steering and performance-based routing policies are configured. The first section applies to Internet traffic only. Because no load-balancing is configured, traffic chooses the primary uplink (WAN 1 in this case) unless there is a policy to steer it differently. In this example, the following policies are preferred:

- Guest traffic is directed over WAN 1. If the link is declared down, the traffic is redirected to WAN 2.
- SaaS Traffic is directed over WAN 2 and should be redirected to WAN 1 if performance is poor.
- Device dashboard traffic is directed over WAN 2. If the link is declared down, the traffic is redirected to WAN 1.

Guest traffic doesn't need to be included in the policy since this is the default behavior when no load-balancing is chosen and the primary uplink is WAN 1.

Note: Traffic generated from the MX itself is not subjected to policy. Policy applied to dashboard traffic affects the infrastructure devices behind the MX (switches and AP).

A custom performance class for SaaS traffic should be configured before configuring the policy.

Procedure 35. To configure a custom performance class for internet traffic:

Step 1. Go to **Security & SD-WAN > Configure > SD-WAN & Traffic Shaping**.

Step 2. Under **SD-WAN policies > Custom performance classes**, select **Create a new custom performance class** and enter these values:

- **Name** (SaaS_Traffic)
- **Maximum latency (ms)** (150)
- **Maximum jitter (ms)** (50)
- **Maximum loss (%)** (5).

Step 3. Click **Save** or **Save Changes**.

Custom performance classes ⓘ	Name	Maximum latency (ms)	Maximum jitter (ms)	Maximum loss (%)	Action
	SaaS_Traffic	150	50	5	X

Step 4. When creating a policy that leverages the custom performance class just created, the newly created custom performance class may not show up as an option during policy configuration. To work around this, reload the web page after saving the custom performance class and before creating the policy.

Procedure 36. To configure routing policy for internet traffic:

Step 1. Go to **SD-WAN Policies > Internet Traffic**, click **+ Add policy**, specify the **Protocol, Source CIDR, Destination**, and **Uplink Selection**.

Step 2. Click **Save** to add the policy to the dashboard.

Step 3. Repeat to add additional lines of policy.

Create SD-WAN Internet Traffic Policy

Protocol

Any

Source

CIDR ①: 10.10.0.0/16 Port ①: Any

Destination

Application Categories
 Major Applications
 Custom

Office 365 X

VoIP & video conferencing
 All Productivity
 Web file sharing
 Office 365
 Security
 Symphony.NET
 Productivity
 Sharepoint

Step 4. Configure these two uplink selection policies for this example:

Protocol	Source CIDR	Destination type	Destination value	Preferred uplink	Fail over if:	Performance class:
Any	10.10.0.0/16	Application Categories	Productivity>Office 365 VoIP & video conferencing>Webex	WAN 2	Poor performance	SaaS_Traffic
Any	10.250.0.0/16	Custom	CIDR=Any	WAN 2	Uplink Down	N/A

Note: Dashboard destination traffic is Any. The VPN exclusions already defined what specific destination traffic is DIA (dashboard IP address destinations). If the previously configured performance class is missing from the drop-down, reload the web page and re-enter the policy.

Step 5. Click **Save** or **Save Changes**.

SD-WAN policies	
Internet traffic	
Uplink selection policy	Traffic filters
Prefer WAN 2. Fail over if uplink down.	10.250.0.0/16 to Any
Prefer WAN 2. Fail over if poor performance for SaaS_Traffic.	10.10.0.0/16 to Office 365 or WebEx

SD-WAN policies: VPN traffic

In this part of the configuration, traffic steering and performance-based routing policies are configured for VPN traffic. Load-balancing doesn't apply to VPN traffic, so VPN traffic always chooses the primary link (WAN 1 in this case) unless there is a policy to steer it differently. In this example, the following policies are preferred:

- All VoIP and Video Conferencing traffic is directed over WAN 2 and should be redirected to WAN 1 if performance is poor.
- A critical company application (TCP from Any to 10.102.1.161/32:443) is directed over WAN 2 and should be redirected to WAN 1 if performance is poor.
- All other traffic is directed over WAN 1 and should be redirected to WAN 2 if performance is poor.

Custom performance classes for the critical application traffic and default traffic should be configured before configuring the policy.

Procedure 37. To configure custom performance classes for the critical application traffic:

Step 1. Go to **Security & SD-WAN > Configure > SD-WAN & Traffic Shaping**.

Step 2. From **SD-WAN policies > Custom performance classes**, select **Create a new custom performance class** then enter these parameters:

- **Name** (Critical_Apps)
- **Maximum latency (ms)** (150)
- **Maximum jitter (ms)** (20)
- **Maximum loss (%)** (2)

Step 3. Select **Create a new custom performance class** then enter these parameters:

- **Name** (Default_SLA)
- **Maximum jitter (ms)** (100)
- **Maximum loss (%)** (5)

Step 4. Click **Save** or **Save Changes**.

Name	Maximum latency (ms)	Maximum jitter (ms)	Maximum loss (%)	Actions
SaaS_Traffic	150	50	5	×
Critical_Apps	150	20	2	×
Default_SLA	(none)	100	5	×

[Create a new custom performance class...](#)

Procedure 38. To configure the routing policy for VPN traffic:

- Step 1.** Go to **SD-WAN Policies > VPN traffic**, click **Add a preference**.
- Step 2.** Under **Traffic filters**, click **Add +** then select an application or application family or create a custom expression to match VPN traffic.
- Step 3.** Select the preferred uplink then click **Save**.
- Step 4.** Repeat to add any additional lines of policy.

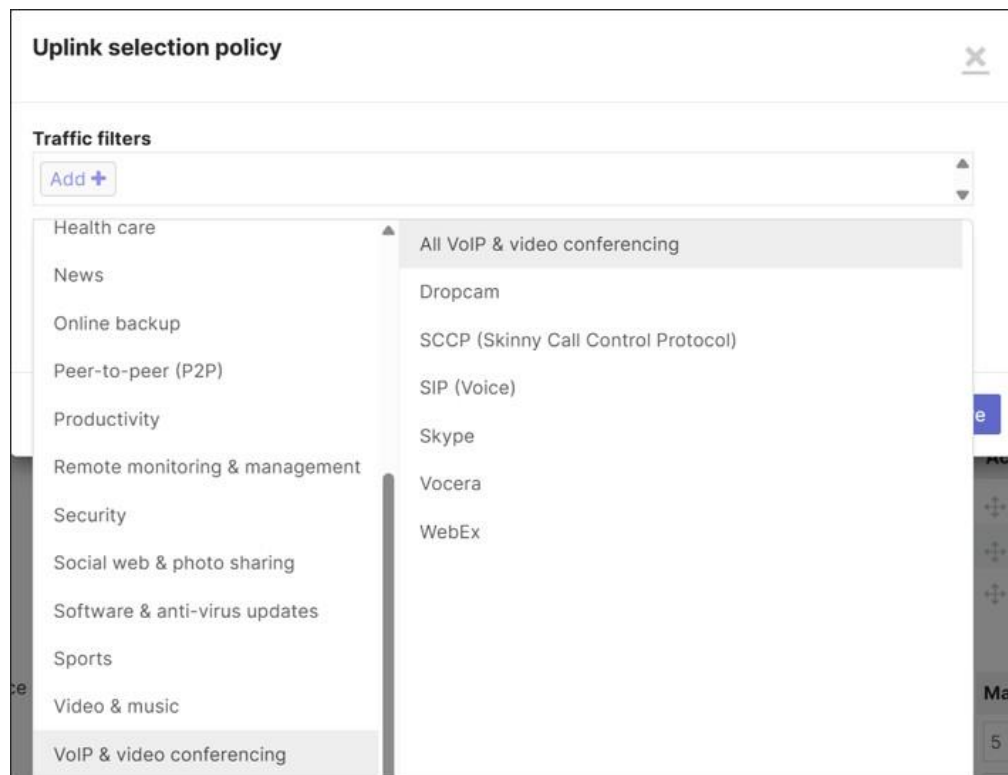

This example configures these three uplink selection policies:

Traffic filters	Preferred uplink	Fail over if:	Performance class:
VoIP & video conferencing>All VoIP & video conferencing	WAN 2	Poor performance	VoIP
Custom expressions>Protocol TCP from Source Any/Src port Any to Destination IP 10.102.1.161/32 Dst port 443	WAN 2	Poor performance	Critical_Apps
Custom expressions>Protocol Any from Source Any Src port Any to Destination Any Dst port Any	WAN 1	Poor performance	Default_SLA

- Step 5.** Click **Save** or **Save Changes**.

VPN traffic	Uplink selection policy	Traffic filters	Actions
	Prefer WAN 2. Fail over if poor performance for VoIP.	All VoIP & video conferencing	☰ ×
	Prefer WAN 2. Fail over if poor performance for "Critical_Apps". (TCP from Any to 10.102.1.161/32:443)		☰ ×
	Prefer WAN 1. Fail over if poor performance for "Default_SLA". (Any to Any)		☰ ×
	Add a preference		

Traffic Shaping rules

In this example, the default traffic shaping rules are kept and only two additional rules are added. The two rules are to give lower priority to guest traffic and give higher priority to the critical application traffic that was referenced in **SD-WAN policies > VPN traffic**.

Procedure 39. To configure traffic shaping rules:

Step 1. Under **Security & SD-WAN > Configure > SD-WAN & Traffic Shaping > Traffic shaping rules**, next to **Default Rules**, ensure that **Enable default traffic shaping rules** is selected.

Step 2. Click **Create a new rule**.

Step 3. Specify these values:

- which traffic should be matched?
- what bandwidth limit should be applied, if any?
- what is the designated priority for this traffic?
- are there any DSCP tagging requirements?

For additional rules, click **Add a new shaping rule**.

This is the configuration for this example:

Rule #	Definition	Bandwidth limit	Priority	DSCP tagging
1	Custom expressions>172.16.99.0/24 (guest)	Ignore network per-client limit (unlimited)	Low	0 (CS0/DF - Best Effort/Default Forwarding)
2	Custom expressions>10.102.1.161/32:443	Ignore network per-client limit (unlimited)	High	18 (AF21 - Low Latency Data, Low Drop)

Step 4. Click **Save Changes**.

Traffic shaping rules

Default Rules

Enable default traffic shaping rules ▾

Traffic Type	DSCP tag
SIP (Voice)	46 (EF - Expedited Forwarding, Voice)
All Advertising, All Software Updates, All Online Backups	10 (AF11 - High Throughput, Latency Insensitive, Low Drop)
WebEx, Skype	34 (AF41 - Multimedia Conferencing, Low Drop)
All Video & Music	18 (AF21 - Low Latency Data, Low Drop)

Rule #1

Definition

This rule will be enforced on traffic matching any of these expressions.

net 172.16.99.0/24  Add 

Bandwidth limit

Ignore network per-client limit (unlimited) ▾

Priority

Low ▾

DSCP tagging

0 (CS0/DF - Best Effort/Default Forwarding) ▾

Rule #2

Definition

This rule will be enforced on traffic matching any of these expressions.

net/port 10.102.1.161/32:443  Add 

Bandwidth limit

Ignore network per-client limit (unlimited) ▾

Priority

High ▾

DSCP tagging

18 (AF21 - Low Latency Data, Low Drop) ▾

MX router: Configure threat protection

Procedure 40. To configure threat protection:

- Step 1.** Under the **Security & SD-WAN > Configure > Threat Protection** page, Advanced Malware Protection (AMP) and Intrusion detection and prevention can be configured.
- Step 2.** Under **Advanced Malware Protection (AMP)**, ensure the **Mode** is set to **Enabled**.
- Step 3.** Under **Intrusion detection and prevention**, set the **Mode** to **Prevention** and select **Balanced** next to **Ruleset**.
- Step 4.** Click **Save** or **Save Changes**.

Threat protection

Advanced Malware Protection (AMP)

Mode ⓘ	Enabled ▾
Allow list URLs ⓘ	There are no URLs on the Allow list. Add a URL to the Allow list
Allow list files	There are no files on the Allow list. Add a file to the Allow list

Intrusion detection and prevention

Mode ⓘ	Prevention ▾
Ruleset ⓘ	Balanced ▾
Allow list rules ⓘ	There are no IDS rules on the Allow list. Add an IDS rule to Allow list

MX router: Configure content filtering

Procedure 41. To configure content filtering:

Step 1. Go to **Security & SD-WAN > Configure > Content Filtering**.

Step 2. Under **Category blocking**, select what content and threat categories should be blocked, as well as any URLs that should be allowed or blocked under **URL filtering**.

Configuration for this example:

Category blocking

Block URLs by website and threat category. See the [full category list](#).

Block

Content categories

- Adult X
- Hate Speech X
- Illegal Activities X
- Illegal Drugs X
- Pornography X
- Child Abuse Content X
- Illegal Downloads X
- Terrorism and Violent Extremism X

Threat categories

- Malware Sites X
- Spyware and Adware X
- Phishing X
- Botnets X
- Spam X
- Exploits X
- High Risk Sites and Locations X
- Bogon X
- Ebanking Fraud X
- Indicators of Compromise (IOC) X
- Domain Generated Algorithm X
- Open HTTP Proxy X
- Open Mail Relay X
- TOR exit Nodes X
- Newly Seen Domains X
- Cryptojacking X
- Linkshare X
- Malicious Sites X

www.example.com is included in the URL filtering blocked URL list>

URL filtering

Enter specific URLs to block or allow. You can use **Category blocking** to block a large number of sites by category rather than entering a list of specific URLs here. [Learn more](#)

Block

Blocked URL list

Targets specific URLs to block

Step 3. Click **Save**.

The screenshot shows a browser window with the address bar containing `wired.meraki.com:8090/blocked.cgi?blocked`. The main content area displays a message: "This website is blocked by your network operator." Below this, a box provides instructions: "If you feel you have received this message in error, please contact your network operator with the following information:" followed by a list of details: URL: `http://www.example.com/`, Category: `User-defined Blacklist`, and Server: `104.18.27.120:80`.

Modify INFRA device management

Now that the MX router and switch ports to the transports have been configured, the infrastructure devices (switches and AP) can be moved into VLAN 999. Ensure that centralized DNS is available before putting the devices into the INFRA VLAN 999.

Switch: Configure trunk to AP with Native VLAN 999

The AP is moved into VLAN 999 by modifying the native VLAN of the trunk port connected to it.

Procedure 42. To configure a trunk to the AP with native VLAN 999:

- Step 1.** Go to **Switching > Monitor > Switch Ports**.
- Step 2.** Click the switch port to the AP (B2-SW1/9) to edit the settings.
- Step 3.** Next to **Native VLAN**, type 999, then click **Update**.

The screenshot shows the 'Update 1 port' configuration window for switch port B2-SW1/9. The configuration includes:

- Switch / Port: B2-SW1 / 9
- Name: (empty text field)
- Port status: Enabled (selected), Disabled
- Link negotiation: Auto negotiate (dropdown)
- Port schedule: Unscheduled (dropdown)
- Tags: (+) (text field)
- Port profile name: (empty dropdown)
- Type: Trunk (selected), Access
- Access policy: Open (dropdown)
- Native VLAN: 999 (dropdown, highlighted with a red box)

Buttons at the bottom: Cancel, Update

- Step 4.** When configured, go to **Wireless > Monitor > Access Points**, and select the AP to validate the changes.

It could take a few minutes for the IP changes to take place. The new IP address is the one that was reserved configuring DHCP pools for the INFRA VLAN on the MX router.

LAN IP 

10.250.2.21

Type

via DHCP

Link Aggregate

Enabled

Switch: Configure switch management VLAN

For all switches and switch stacks, switch management traffic is tagged with VLAN 999.

Procedure 43. To set the switch management VLAN:

Step 1. Go to **Switching > Configure > Switch Settings** and under **VLAN configuration > Management VLAN**, configure 999.

Step 2. Click **Save changes**. This sets the management VLAN for all switches in the network.

The local switch setting overrides this setting.

Switch settings

VLAN configuration

Management VLAN ⓘ

Save changes Cancel

Step 3. When configured, go to **Switching > Monitor > Switches**, select a switch to validate the changes. It could take a few minutes for the IP changes to take place. The new IP address is one that was reserved configuring DHCP pools for the INFRA VLAN on the MX router.

LAN IPv4	
10.250.2.11	
Type	
Via DHCP	
Interface	
Vlan 999	
Public IP	
Gateway	
10.250.2.1	
DNS	
10.102.1.160	
10.102.1.161	

Tech tip: For some MS switch stack models (such as the MS150, but not the MS390), there may be an issue moving all switch members into VLAN 999. Some members may switch to VLAN 999, and others may stay in VLAN 1. If any switch stays in VLAN 1, there will be no reachability to centralized services (such as RADIUS) in the data center for that switch. If this issue occurs, instead of modifying the switch settings, configure the native VLAN 999 on the trunk of the MX router (go to **Security & SD-WAN > Configure > Addressing & VLANs**, **Edit** the trunk ports connected to the switch stack, and configure the **Native VLAN** as 999). This may generate a VLAN mismatch error on the switch, but the switch should be able to obtain an IP address and have reachability in VLAN 999 using the workaround. Any devices that are onboarded afterwards should obtain an IP address in VLAN 999 instead of VLAN 1. If this workaround is implemented, any switch trunk to an Access Point must be configured for Native VLAN 1 (and not VLAN 999).

Switch: Configure switch settings

Spanning tree root

The switch is configured to be the root of spanning tree.

Procedure 44. To configure spanning-tree settings:

- Step 1.** Go to **Switching > Configure > Switch Settings** under **STP configuration**.
- Step 2.** Click **Set the bridge priority for another switch or stack**.
- Step 3.** A window may pop up warning that changing the STP bridge priority may cause a short disruption on all switches in the network as spanning tree is re-calculated. Click **Got it**.
- Step 4.** Click the text box under **Default**.
- Step 5.** From the drop-down menu **Switches/Stacks** name (B2-SW-STACK1) and under **Bridge priority**, from the drop-down menu, select **4096**.
- Step 6.** Click **Confirm**.

STP configuration Enable Rapid Spanning Tree (RSTP) ⓘ

STP bridge priority ⓘ

Switches/Stacks	Bridge priority	Actions
Default	32768	
B2-SW-STACK1	4096	

+ Set the bridge priority for another switch or stack

Save changes **Cancel**

Step 7. Click **Save changes**.

Quality of Service (QoS)

In this example, minimal Quality of Service configurations are made. Under **Switching > Configure > Switch Settings > Quality of service**, default DSCP-to-CoS mappings are retained. Guest traffic (VLAN 50) is untrusted with all traffic set to 0 (default), while incoming DSCP is trusted for Data (VLAN 10), Voice (VLAN 20), IOT (VLAN 30), and PCI traffic (VLAN 40).

Procedure 45. To configure QoS:

- Step 1.** Click **+ Add a QoS Rule for this network**.
- Step 2.** Fill in **VLAN, Protocol (ANY)**, and whether to **Trust incoming DSCP**.
- Step 3.** If DSCP is not trusted, **set DSCP** to a value.
- Step 4.** Click **Save**.
- Step 5.** Repeat until all VLANs are entered.

Quality of service ⓘ

Successfully created QoS rule ⓘ

#	VLAN	Protocol	Source port ⓘ	Destination port ⓘ	Trust incoming DSCP	Set DSCP to	Actions
1	50	ANY	—	—	<input type="checkbox"/>	0 → 0(default)	...
2	10	ANY	—	—	<input checked="" type="checkbox"/>	—	...
3	20	ANY	—	—	<input checked="" type="checkbox"/>	—	...
4	30	ANY	—	—	<input checked="" type="checkbox"/>	—	...
5	40	ANY	—	—	<input checked="" type="checkbox"/>	—	...

+ Add a QoS Rule for this network

Edit DSCP to CoS map

Storm control

In this example, storm control is configured on the wired access ports.

Procedure 46. To configure storm control:

Step 1. Go to **Switching > Configure > Switch Settings** and under **Storm control**, click **+ Set the port bandwidth for another traffic type**.

Step 2. Enter the **Traffic type** and **% of available port bandwidth**.

Step 3. Click **Confirm**.

Step 4. Repeat to finish the traffic types.

Step 5. When finished, click **Save changes**.

Tech tip: While percentages for what is normal traffic varies for each network, in this example, multicast traffic is set to 30%, broadcast traffic is set to 20%, and unknown unicast is set to 10%. It is important to understand the network applications and to monitor interface statistics for broadcast/multicast traffic to determine what is normal for the network. Ensure the percentages allow normal network traffic to flow correctly, especially before applying the settings to uplink and AP ports.



The screenshot shows the 'Storm control' configuration page. At the top, there is a green success message: 'Successfully updated storm control'. Below this is a table with three columns: 'Traffic types', '% of available port bandwidth', and 'Actions'. The table lists three traffic types: Broadcast (20%), Multicast (30%), and Unknown Unicast (10%). Each row has edit and delete icons. At the bottom of the table, there is a link: '+ Set the port bandwidth for another traffic type'.

Traffic types	% of available port bandwidth	Actions
Broadcast	20%	
Multicast	30%	
Unknown Unicast	10%	

Switch: Configure access policies

Procedure 47. To configure 802.1x on the switch:

Step 1. In this example, go to **Switching > Configure > Access Policies**.

Step 2. Click **+ Add policy**.

Step 3. Configure a **Name** (RADIUS-MAB) and **Authentication method** (RADIUS server).

Step 4. Check the check boxes for **RADIUS Server testing**, **RADIUS CoA support**, and **Enable RADIUS accounting servers**.

Step 5. Click **+ Add a server** and enter the **Host**, **Secret**, and **Port** number for RADIUS Auth and Accounting.

Access Policy Detail

Name:

Authentication method:

RADIUS servers:

- RADIUS Server testing ⓘ
- RADIUS CoA support ⓘ
- Enable RADIUS accounting servers

#	Name	Host	Secret	Auth	Port	Accounting	Port	Actions
1		<input type="text" value="10.102.1.15"/>	<input type="text" value="..... Show"/>	<input checked="" type="checkbox"/>	<input type="text" value="1812"/>	<input checked="" type="checkbox"/>	<input type="text" value="1813"/>	

Select RADIUS: + Add a server

Step 6. Next to **Connection** under **Policy Type**, select **Hybrid authentication** since both 802.1x and Mac Authentication Bypass can be used. **Host mode** is set to **Multi-Auth** and **802.1x control direction** defaults to **Both**.

Step 7. Next to **Options**, select **Voice auth**.

RADIUS attribute specifying group policy name:

Connection:

Policy Type:

Host mode ⓘ:

802.1X control direction:

Re-authentication interval ⓘ:

Concurrent Authentication

Options:

Voice auth

Disable port bounce ⓘ

Step 8. Click **Save**.

Access policies

1 policy

Policy name	Affected ports	Host mode	Actions
<input type="checkbox"/> RADIUS-MAB	0	Multi-Auth	

Authentication method my RADIUS server

Host 10.102.1.157:1812 (radius role: Auth)
10.102.1.157:1813 (radius role: Acct)

Policy type Hybrid authentication

Switch: Configure ports

In this example, the following port configurations are completed. Ports 3-5 (transport ports) on each switch have already been configured, and others have been partially configured.

Ports 1-2 (SW1/SW2): Uplink ports to the routers

Port 9 (SW1): Link to the access point (AP)

Ports 6-8 (SW1/SW2): Unused Infrastructure (shutdown)

Ports 10-12 (SW1): Unused AP ports (shutdown)

Ports 9-12 (SW2): Unused AP ports (shutdown)

Ports 13-28 (SW1/SW2): Wired client ports

Ports 1-2: Uplink ports

Procedure 48. To configure an uplink port:

Step 1. Go to **Switching > Monitor > Switch Ports**. Ports 1 and 2 on each switch are the uplinks to the MX routers in our example and will retain most of the default settings.

Step 2. The **Name** and **Allowed VLANs** are already configured in a previous section. Check the check boxes to the far left of **Switch / Port** B2-SW1/1, B2-SW1/2, B2-SW2/1, and B2-SW2/2 and click **Edit**.

Note: The **Storm control** option appears when the storm control settings are configured. It is important to not set the storm control settings too low before applying them to ports as legitimate traffic can be dropped.

Step 3. Verify these setting configurations:

- **Name:** Uplink to Router
- **Port Status:** Enabled
- **Link negotiation:** Auto negotiate
- **Port schedule:** Unscheduled
- **Type:** Trunk
 - **Access policy:** Open
 - **Native VLAN:** 1
 - **Allowed VLANs:** 1,10,20,30,40,50,999
- **STP guard:** Disabled
- **Port isolation:** Disabled
- **Trusted DAI:** Disabled
- **UDLD:** Alert only
- **PoE:** Enabled
- **Storm control:** Enabled

Step 4. Click **Update**.

Status	Switch / Port	Name	Type	VLAN
<input checked="" type="checkbox"/>	B2-SW2 / 1 details	Uplink to MX Secure Router	trunk	native 1
<input checked="" type="checkbox"/>	B2-SW2 / 2 details	Uplink to MX Secure Router	trunk	native 1

Port 9: Access Point (AP) port

In this example, Port 9 on B2-SW1 is connected to the access point. By default, the port is configured as a trunk carrying all VLANs.

Note: The native VLAN was originally 1 but now set to VLAN 999 in a previous step in order to put the AP management traffic into VLAN 999.

RSTP is also already enabled, UDLD is set to Alert only, PoE is enabled, and Storm control is enabled because it is enabled by default when storm control settings have been configured under **Switching > Monitor > Switch settings**.

Procedure 49. To configure the link to the AP:

Step 1. Click **Switch / Port B2-SW1/9**.

Step 2. Configure these settings:

- **Name:** Link to AP
- **Allowed VLANs:** 1,10,20,30,40,50,999
- **STP Guard:** BPDU guard

The screenshot shows the 'Update 1 port' configuration window for port B2-SW1/9. The window is titled 'Update 1 port' and has a close button (X) in the top right corner. The configuration is as follows:

- Switch / Port: B2-SW1 / 9
- Name: Link to AP (highlighted with a red box)
- Port status: Enabled (selected), Disabled
- Link negotiation: Auto negotiate
- Port schedule: Unscheduled
- Tags: +
- Port profile name: (empty)
- Type: Trunk (selected), Access
- Access policy: Open
- Native VLAN: 1
- Allowed VLANs: 1,10,20,30,40,50,999 (highlighted with a red box)
- Peer SGT capable: Enabled (selected), Disabled
- Adaptive policy group: 2: Infrastructure
- RSTP: Enabled (selected), Disabled
- STP guard: BPDU guard (highlighted with a red box)

At the bottom right, there are 'Cancel' and 'Update' buttons.

Step 3. Click **Update**.

Ports 6-12: Unused Infrastructure/AP ports

Unused ports 6-8 and 10-12 on both switches are disabled, and port 9 is also disabled on B2-SW2.

Procedure 50. To configure unused infrastructure and AP ports:

Step 1. Check the check box to the left of each port and click **Edit** at the top of the screen.

Step 2. Next to **Name**, type *Disabled*.

Step 3. Next to **Port status**, click **Disabled**.

Update 13 ports [X]

Settings are applied to all ports selected, including all ports in aggregate groups

Switch / Port	B2-SW2 / 6 B2-SW2 / 7 B2-SW2 / 8 B2-SW2 / 9 B2-SW2 / 10 B2-SW2 / 11 B2-SW2 / 12 B2-SW1 / 6 B2-SW1 / 7 B2-SW1 / 8 B2-SW1 / 10 B2-SW1 / 11 B2-SW1 / 12
Name	Disabled
Port status	Enabled Disabled
Link negotiation	Auto negotiate
Port schedule	Unscheduled
Tags	

Cancel Update

Step 4. Click **Update**.

Ports 13-28: Wired client ports

Procedure 51. To configure wired client ports:

Step 1. For the rest of the ports (ports 13-28), on both switches, check the check box to the left of each port and click **Edit** at the top of the screen.

Clicking a box, then holding the shift key and clicking a box further down the list selects a range.

Note: RSTP and Storm control are already enabled, and UDLD is set to Alert only.

Step 2. Configure these settings:

- **Name:** Access Port

- **Type:** Access
- **Access policy:** RADIUS-MAB
- **VLAN:** 10
- **Voice VLAN:** 20
- **STP Guard:** BPDU Guard

Update 32 ports
✕

Name

Port status

Enabled
Disabled

Link negotiation

Auto negotiate ▼

Port schedule

Unscheduled ▼

Tags

+

Port profile name

▼

Type

Trunk
Access

Access policy ⓘ

RADIUS-MAB ▼

VLAN

10 ▼ ✎

Voice VLAN

20 ▼ ✎

Cancel
Update

Step 3. Click **Update**.

Wireless Access Point: Configure Guest SSID

Access control

Procedure 52. To configure Guest wireless access control:

Step 1. Go to **Wireless > Configure > Access Control**.

Step 2. From the drop-down menu, select an unconfigured SSID (SSID 1, labeled RTP6-Branch2 - wireless Wi-Fi).

Step 3. Provide an **SSID name** (in this example BR2-GuestWiFi), and next to **SSID status**, select **Enabled**. The SSID will not be hidden.

Access control

SSID

RTP6-Branch2 - wireless WiFi

Basic info

SSID (name)

BR2-GuestWiFi

SSID status

Enabled

Disabled

Hide SSID

Step 4. Select **Security (Open (no encryption))**, enable **Mandatory DHCP**, and under **Splash page**, select **Click-through** – this requires guests to view and acknowledge a splash page before being allowed on the network.

Step 5. Under **Client IP and VLAN**, select **External DHCP server assigned** and leave the setting in **Bridged** mode.

Step 6. Next to **VLAN tagging**, from the drop-down menu, select the **VLAN ID** field and enter **50**. This value represents the pre-configured Guest VLAN, which is already enabled on the trunk connecting the AP/switch to the MX router.

Step 7. Click **Save**.

Meraki AP assigned (NAT mode)
 Clients receive IP addresses in an isolated 10.0.0.0/8 network. Clients cannot communicate with each other, but they may communicate with devices on the wired LAN if the SSID firewall settings permit.

External DHCP server assigned
 Meraki devices operate transparently (do not perform NAT or DHCP). Wireless clients will receive DHCP leases from a server on the LAN or use static IPs. Use this for wireless clients requiring seamless roaming, shared printers, and wireless cameras.

Bridged Tunneled

Layer 3 roaming

RADIUS guest VLAN ⓘ Disabled

Bonjour forwarding
 Bridge mode only Enabled **Disabled**

VLAN tagging ⓘ VLAN ID

#	Access point tags	VLAN ID
	Default	50

[+ Add VLAN ID](#)

Step 8. On this same page, scroll up above the RADIUS section and click **Splash page settings**.

Customize the look and feel of your splash page from [Splash page settings](#).

RADIUS

Step 9. Under the **Splash page**, select the guest SSID (BR2-GuestWiFi).

Step 10. Under **Official themes**, ensure **Modern** is selected.

Step 11. Under **Customize your page** next to **Welcome message**, type “Click to continue if you agree to the terms of usage of this guest service.”

Step 12. Click **Save** or **Save Changes**.

Splash pages on this SSID are enabled because a click-through splash page is enabled. You can change this setting on the [access control subtab](#).

Official themes ⓘ

Modern NEW

Fluid

Custom themes ⓘ

[Create something new](#)

Custom splash URL

Or provide a URL where users will be redirected:

[What is this?](#)

Color customization

Color Motif: Plain ▼

Background Text

Content 1

Preview

Customize your page

Welcome message

Firewall and traffic shaping

Procedure 53. To configure Guest wireless firewall and traffic shaping:

Step 1. Under **Wireless > Firewall & Traffic Shaping**, select the guest SSID from the drop-down menu (BR2-GuestWiFi).

Step 2. Under **Block IPs and ports** next to **Layer 2 LAN isolation**, select **Enabled**.

Block IPs and ports

Layer 2 LAN isolation (bridge mode only)

Step 3. Under **Outbound rules**, ensure that **Deny** is selected for “IPv4 Any Local LAN Any” for the **Wireless clients accessing LAN** rule.

Outbound rules

#	Policy	IP Version	Protocol	Destination	Dst port	Rule description	Actions
No custom rules defined							
	<input type="text" value="Deny"/>	IPv4	Any	Local LAN	Any	Wireless clients accessing LAN	
	<input checked="" type="text" value="Allow"/>	IPv4	Any	Any	Any	Default rule	

Step 4. For this example, under **Traffic shaping rules**, set the **Per-client bandwidth limit** to 50 Mbps and **Enable SpeedBurst**.

Step 5. Set the **Per-SSID bandwidth limit** to 100 Mbps.

Step 6. Next to **Shape traffic**, select **Shape traffic on this SSID** and next to **Default Rules**, verify that **Enable default traffic shaping rules** is selected.

Traffic shaping rules

Per-client bandwidth limit: 50 Mbps [details](#) Enable SpeedBurst ⓘ

Per-SSID bandwidth limit ⓘ: 100 Mbps [details](#)

Shape traffic: Shape traffic on this SSID ▼

Default Rules: Enable default traffic shaping rules ▼

Step 7. Click **Save Changes**.

Network-Wide: Configure group policy

In this example, group policy is applied after RADIUS authentication occurs in the Corp wireless SSID. The RADIUS server passes back a filter-ID parameter, which corresponds to a group policy name and is applied to the wireless user accessing the network. In this example, there are 4 policy groups: DATA, VOICE, IOT, and PCI. The policy groups assign a VLAN but do not assign an SGT in this example. The SGT is assigned through a separate RADIUS attribute. If SGTs were assigned, more policies would need to be created to cover different user groups under the DATA VLAN.

Procedure 54. To configure group policy for Corp wireless:

- Step 1.** Go to **Network-wide > Group Policies** and click **Add a group**.
- Step 2.** Next to **Name**, type DATA, and next to **Adaptive Policy SGT**, select **Do not assign SGT**.
- Step 3.** Under **Wireless only**, next to **VLAN**, from the drop-down menu, select **Tag VLAN** and type 10 in the box.
- Step 4.** Click **Save Changes**.
- Step 5.** Repeat for VOICE (VLAN 20), IOT (VLAN 30), and PCI (VLAN 40).

Adaptive Policy SGT ⓘ: Do not assign SGT ▼ 0: Unknown ▼

SGT value 0 (Unknown group) is not a valid value. Please "Do not assign SGT" or select a different SGT value.

Wireless only

VLAN: Tag VLAN ▼ 10

Splash: Use network default ▼

Bonjour forwarding ⓘ
Bridge mode SSIDs only: Use network default ▼

There are no Bonjour forwarding rules on this network.
[Add a Bonjour forwarding rule](#)

Wireless Access Point: Configure corporate SSID

Access control

Procedure 55. To configure Corp wireless access control:

Step 1. Go to **Wireless > Configure > Access Control**.

Tech tip: In order for Corporate WiFi with WiFi 7 to co-exist with a less secure Guest WiFi on the same AP, the SSIDs must be placed into separate SSID groups. The SSID group feature is still in BETA in the latest stable release candidate at the time of this writing, so the access points are still on the latest stable release (31.1.8) and are not yet upgraded. To prevent having to migrate to another SSID in the future, put the Corporate WiFi on a different SSID group from the less-secure Guest WiFi. There are four SSIDs per group (SSID #1-4, SSID #5-8, SSID #9-12, and SSID #13-15).

Step 2. Select an unconfigured SSID (in a separate SSID group from Guest Wi-Fi) from the drop-down menu, which can be any SSID from #5-15 in this example.

Step 3. Provide an **SSID name** (in this example, BR2-CorpWiFi) and next to **SSID status**, select **Enabled**. The SSID will not be hidden.

Access control

SSID
Unconfigured SSID 5

Basic info

SSID (name) BR2-CorpWiFi

SSID status **Enabled** Disabled

Hide SSID

Step 4. Under **Security**, select **Enterprise with my RADIUS server**.

Security *WPA2 Enterprise with 0 RADIUS servers*

 This SSID will not broadcast on the 6 GHz band. Use WPA3 to enable this band.

Open (no encryption)
Any user can associate

Opportunistic Wireless Encryption (OWE)
Any user can associate with data encryption

Password
Users must enter a passphrase to associate ⓘ

MAC-based access control (no encryption)

RADIUS server is queried at association time

Enterprise with

User credentials are validated with 802.1X at association time

Step 5. Next to **WPA encryption**, select **WPA3 Transition Mode**.

Step 6. Next to **802.11w** (management frame protection) verify that **Enabled (allow unsupported clients)** is selected.

Step 7. Next to **Mandatory DHCP**, select **Enabled**.

Wi-Fi Personal Network (WPN) ⓘ	<input type="button" value="Enabled"/> <input checked="" type="button" value="Disabled"/>
WPA encryption ⓘ	WPA3 Transition Mode ▾
802.11w ⓘ	<input checked="" type="radio"/> Enabled (allow unsupported clients) <input type="radio"/> Required (reject unsupported clients) <input type="radio"/> Disabled (never use)
<div style="border: 1px solid #ccc; padding: 5px; margin-top: 10px;"> Traffic from static IP address clients will be blocked on this SSID. </div>	
Mandatory DHCP	<input checked="" type="button" value="Enabled"/> <input type="button" value="Disabled"/>
Local Auth Fallback ⓘ	<input type="button" value="Enabled"/> <input checked="" type="button" value="Disabled"/>

Step 8. Under the **Splash page**, verify that **None (direct access)** is selected.

Splash page *None*

Not all splash authentication methods are compatible with WPA2-Enterprise authentication

None (direct access)
 Users can access the network as soon as they associate

Step 9. Scroll down and click **RADIUS** to open the RADIUS settings.

Step 10. Under **RADIUS servers**, click **Add server** and enter the **Host IP or FQDN** (10.102.1.157), **Auth** (Authentication) **port** (1812), and **Secret** password.

Step 11. Optionally, test the server connectivity.

Step 12. Click **Done**.

Step 13. Under **RADIUS accounting servers**, select **Add server** and enter the **Host IP or FQDN** (10.102.1.157), **Acct** (Accounting) **port** (1813), **Secret** password, and click **Done**.

Step 14. RADIUS CoA is not enabled due to the enabling of the fast-roaming feature. Next to **RADIUS attribute specifying group policy name**, verify that **Filter-Id** is selected.

RADIUS 1 RADIUS server, 1 accounting server

RADIUS servers

#	Host IP or FQDN	Auth port	Secret	RadSec ⓘ	Test	Actions
1	10.102.1.157	1812	<input type="checkbox"/>	<input type="button" value="Test"/>	...

Add server 3 max.

RADIUS accounting servers

#	Host IP or FQDN	Acct port	Secret	RadSec ⓘ	Actions
1	10.102.1.157	1813	<input type="checkbox"/>	...

Add server 3 max.

Accounting interim interval minutes

Accounting start delay seconds

RADIUS Accounting Device Profiling support ⓘ

RADIUS testing ⓘ

RADIUS CoA support ⓘ

Dashboard RADIUS proxy ⓘ

RADIUS attribute specifying group policy name

Step 15. Under **Client IP and VLAN**, select **External DHCP server assigned** and verify **Bridged** mode is selected.

Step 16. Next to **RADIUS override**, verify that **Override VLAN tag** is selected.

Step 17. Under **VLAN tagging**, select **VLAN ID**, and under **VLAN ID**, type in 10. This is the default VLAN for authenticated users if VLAN IDs or group policy names are not passed by RADIUS. VLAN 10 is the DATA VLAN already defined on the MX router and carried on the trunk between the AP/switch and the MX router/switch.

Client IP and VLAN *Bridge mode*

External DHCP server assigned
 Meraki devices operate transparently (do not perform NAT or DHCP). Wireless clients will receive DHCP leases from a server on the LAN or use static IPs. Use this for wireless clients requiring seamless roaming, shared printers, and wireless cameras.

Layer 3 roaming

RADIUS override ⓘ

RADIUS guest VLAN ⓘ

Bonjour forwarding
 Bridge mode only

VLAN tagging ⓘ

#	Access point tags	VLAN ID
	Default	<input type="text" value="10"/>

[+ Add VLAN ID](#)

Step 18. Scroll back up to the **Security** section.

Step 19. Next to **802.11r** (fast roaming) select **Enabled**. This feature is not available under **Meraki AP assigned (NAT mode)** and becomes available when **External DHCP server assigned** is selected. In this version of code, fast roaming cannot be enabled if RADIUS CoA support is enabled.

Wi-Fi Personal Network (WPN) ⓘ

WPA encryption ⓘ

802.11r ⓘ Enabled
 Adaptive
 Disabled

802.11w ⓘ Enabled (allow unsupported clients)
 Required (reject unsupported clients)
 Disabled (never use)

Step 20. Click **Save**.

Firewall and traffic shaping

Procedure 56. To configure Corp wireless firewall and traffic shaping:

Step 1. Under **Wireless > Firewall & Traffic Shaping**, select the Corp SSID from the drop-down menu (BR2-CorpWiFi).

Step 2. Leave the defaults. The configuration should look like:

- **Block IPs and ports**
 - **Layer 2 LAN isolation:** disabled
 - **DHCP guard:** Disabled
 - **RA guard:** Enabled
 - **Outbound rules:** Allow IPv4 Any Local LAN Any (Wireless clients accessing LAN)
 - **Outbound rules:** Allow IPv4 Any Any Any (Default rule)
- **Traffic shaping rules**
 - **Per-client bandwidth limit:** unlimited
 - **Per-SSID bandwidth limit:** unlimited
 - **Shape traffic:** Shape traffic on this SSID
 - **Default Rules:** Enable default traffic shaping rules

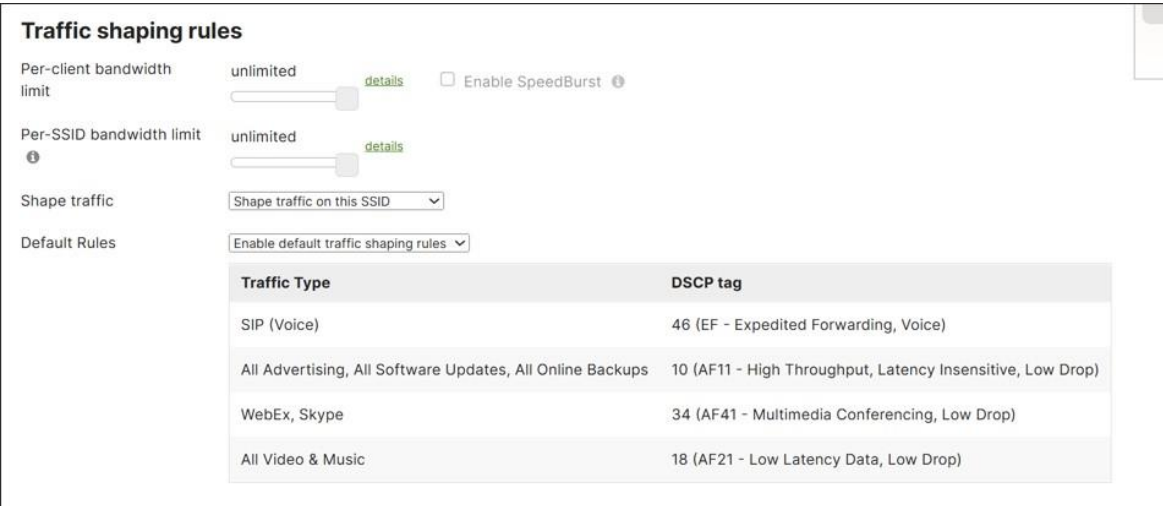

Traffic Type	DSCP tag
SIP (Voice)	46 (EF - Expedited Forwarding, Voice)
All Advertising, All Software Updates, All Online Backups	10 (AF11 - High Throughput, Latency Insensitive, Low Drop)
WebEx, Skype	34 (AF41 - Multimedia Conferencing, Low Drop)
All Video & Music	18 (AF21 - Low Latency Data, Low Drop)

Wireless Access Point: Configure SSID availability

Procedure 57. To configure SSID availability:

Step 1. Go to **Wireless > Configure > SSID Availability** and select an **SSID** (BR2-CorpWiFi).

Step 2. Next to **Scheduled availability**, select **enabled**.

Step 3. Next to **Schedule templates**, ensure **Custom schedule** is selected.

Step 4. Configure these schedules:

- Sunday, unavailable, From 0:00 to 24:00
- Monday-Friday, available, From 7:00 to 19:00
- Saturday, unavailable, From 0:00 to 24:00

Step 5. Click **Save Changes**.

Step 6. Repeat for other SSIDs (BR2-GuestWiFi).

Visibility	<input type="text" value="Advertise this SSID publicly"/>		
Per access point availability	<input type="text" value="Enabled on all access points"/>		
Scheduled availability	<input type="text" value="enabled"/>		
Schedule templates	<input type="text" value="Custom schedule"/>		
Local time zone	US - Eastern (You can set this on the Network-wide settings) page.		
Day	Availability	From	To
Sunday	<input type="text" value="unavailable"/>	<input type="text" value="0:00"/>	<input type="text" value="24:00"/>
Monday	<input type="text" value="available"/>	<input type="text" value="7:00"/>	<input type="text" value="19:00"/>
Tuesday	<input type="text" value="available"/>	<input type="text" value="7:00"/>	<input type="text" value="19:00"/>
Wednesday	<input type="text" value="available"/>	<input type="text" value="7:00"/>	<input type="text" value="19:00"/>

Wireless Access Point: Configure radio settings

Procedure 58. To configure radio settings:

Step 1. Go to **Wireless > Configure > Radio Settings**. Select the **RRM** tab.

Step 2. Next to **AI-RRM**, select **Enable**.

AI-RRM	<input checked="" type="checkbox"/> Enable
AI-Enhanced RRM uses an AI engine to improve radio optimization using trend-based RRM decisions.	

Step 3. Click **Save changes** at the bottom of the page.

Step 4. Under **Wireless > Configure > Radio Settings**, select the **RF profiles** tab.

Step 5. Copy the **Basic Indoor Profile**.

Radio settings

Overview **RF profiles** RRM

New Profile

Basic Indoor Profile DEFAULT INDOOR

Applied to 1 access point. No overrides on those access points.

	2.4 GHZ	5 GHZ	6 GHZ
Channel assignment	Auto	Auto	Auto
AutoPower max	30	30	Auto
AutoPower min	5	8	8
Min. bitrate	11	12	12
Channel width		Auto	Auto

CHANGE DEFAULT PROFILE
COPY
EDIT

Step 6. Next to **Profile name**, type a new name (Medium Branch Profile).

Step 7. Next to **Band selection**, select **Per SSID**, and enable **6 GHz** and **Band steering** for BR2-CorpWiFi (**2.4 GHz** and **5 GHz** should already be selected for both BR2-GuestWiFi and BR2-CorpWiFi).

General

Profile name

Band selection All SSIDs Per SSID

Name	2.4 GHz	5 GHz	6 GHz	Band steering ⓘ
BR2-GuestWiFi	<input checked="" type="checkbox"/>	<input checked="" type="checkbox"/>	<input type="checkbox"/>	<input type="checkbox"/>
BR2-CorpWiFi	<input checked="" type="checkbox"/>	<input checked="" type="checkbox"/>	<input checked="" type="checkbox"/>	<input checked="" type="checkbox"/>

[Show disabled SSIDs](#)

Step 8. Click **Save**.

Procedure 59. To associate the AP with the newly edited RF profile:

Step 1. Go to **Wireless > Configure > Radio Settings** and select the **Overview** tab.

Step 2. Select the AP and click **Edit settings**.

Step 3. From the drop-down menu, select **Assign profile**.

Search by access point name 3 Radios: 1 checked

Update auto channels Edit settings...

Bulk edit settings... Assign profile...

Status	Access point name	Channel	Ch. Width (MHz)	Target power (dBm)	Transmit power (dBm)	RF Profile
<input type="checkbox"/>	B2-AP1	1 (Auto)	20	5 - 30	20	Basic Indoor Profile
<input checked="" type="checkbox"/>	B2-AP1	56 (Auto)	80 (Auto)	8 - 30	20	Basic Indoor Profile 99

Step 4. Select the Medium Branch Profile and click **Next**.

Step 5. A window pops up that states that some access points have manually configured settings (power, channel, and channel-width settings) which override profile settings. Clear their manual overrides if needed and select **Review changes**.

Clear overrides on 1 Access Point

Some of these access points have manually configured settings which override profile settings. The power, channel and channel width settings of the chosen RF profile will not apply to the selected access points unless you clear their manual overrides.

- Clear channel width override
- Clear channel overrides
- Clear power overrides

Back Review changes

Step 6. Click **Apply changes**.

Assign profile to 1 Access Point

Review Changes

Access point name	Channel Width	Channel	Transmit power (dBm)	RF Profile
B2-AP1 (2.4 GHz)	20 → 20 (Auto)	1 (Auto) → 1 (Auto)	5 - 30 → 30	Basic Indoor Profile → Medium Branch Profile
B2-AP1 (5 GHz)		56 (Auto) → 56 (Auto)	8 - 30 → 30	Basic Indoor Profile → Medium Branch Profile
B2-AP1 (5 GHz)		n/a → Auto	5 - 30 → 30	Basic Indoor Profile → Medium Branch Profile

Back Apply changes

Configure other network services

SNMP (dashboard polling)

This is configured at the Organization level.

Procedure 60. To configure SNMP, if not already configured:

Step 1. Go to **Organization > Configure > Settings**.

Step 2. Under **SNMP**, verify these settings are configured:

- SNMP V2C disabled
- SNMP V3 enabled
- Authentication mode: SHA
- Privacy mode: AES128

Step 3. Verify strong passwords are set for Authentication and Privacy and configure any IP restrictions (public IP address endpoints that are authorized to poll the dashboard).

SNMP

Version 2C SNMP V2C disabled ▾

Version 3 SNMP V3 enabled ▾

Authentication mode SHA ▾

Authentication password [Show password](#)

Privacy mode AES128 ▾

Privacy password [Show password](#)

Host: snmp.meraki.com, Port: 16100, User: "o/ouOodc", Authentication protocol: SHA, Privacy protocol: AES, [Download MIB](#)
 Example: snmpwalk -v3 -t 10 -l authPriv -u o/ouOodc -a SHA -A <auth pass> -x AES128 -X <priv pass> -Ob -M +. -m +MERAKI-CLOUD-CONTROLLER-MIB
 snmp.meraki.com:16100.1

IP restrictions Enter IP addresses separated by whitespace, commas, or semicolons. Leave blank to allow SNMP queries from all IP addresses.

XX.XXX.XXX.XX

SNMP (dashboard traps)

Procedure 61. To configure SNMP traps:

Step 1. Go to **Network-wide > Configure > Alerts > SNMP traps**.

Step 2. Next to **Access**, select **V3 (username/password)**.

Step 3. Click **Add an SNMP user** and fill out an **SNMP Username** and **Passphrase**. The same passphrase is used for authentication and privacy. The authentication protocol is SHA1, and privacy protocol is AES128.

Step 4. Enter the public IP address of the server that will receive the SNMP traps and configure its receiving port as well.

SNMP traps ⓘ

Access V3 (username/password) ▾

Users ⓘ

Username	Passphrase
snmpuser	<input type="password" value="....."/> 👁️ ✕

[Add an SNMP user](#)

Receiving server IP ⓘ

Receiving server port

[Send test trap](#)

[Download MIB](#)

Step 5. Scroll up to **Alerts Settings**.

Step 6. Add **snmp** in the **Default recipients** box and select any conditions where alerts should be triggered. These are the conditions selected for alerts in this example:

- Network-wide: A rogue access point is detected
- WAN appliance: Malware is downloaded

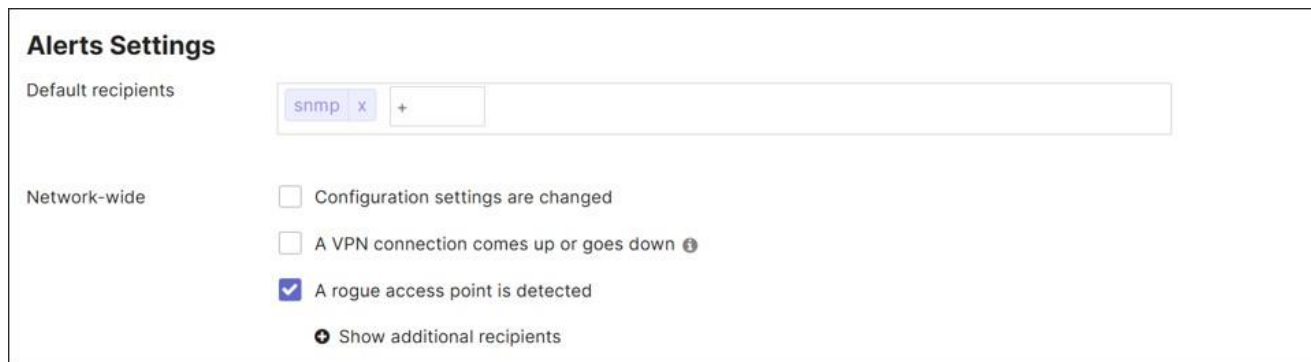

The screenshot shows the 'Alerts Settings' interface. Under 'Default recipients', there is a search box containing 'snmp' and a plus sign to add more. Under 'Network-wide', there are three checkboxes: 'Configuration settings are changed' (unchecked), 'A VPN connection comes up or goes down' (unchecked), and 'A rogue access point is detected' (checked). There is also a 'Show additional recipients' button.

Step 7. Click **Save**.

Syslog

This is configured at the network level.

Procedure 62. To configure syslog for the network devices:

Step 1. Go to **Network-wide > Configure>General**.

Step 2. Under **Reporting > Syslog servers**, click **+ Add a syslog server**. Enter these values:

- **Server address** (10.102.1.160)
- **Port** (514)
- **Protocol** (UDP)
- **Roles** (Wireless Event log, Wireless Air Marshal events, Switch Event log, Appliance Event log, Appliance Security events)

Step 3. Click **Update syslog servers**.



The screenshot shows the 'Reporting' section with a table for 'Syslog servers'. The table has columns for 'Server address', 'Port', 'Protocol', 'Encrypted (TLS) syslog', 'Roles', and 'Actions'. The first row shows '10.102.1.160', '514', 'UDP', 'Enable' (unchecked), and a list of roles: 'Appliance Event log', 'Appliance Security events', 'Switch Event log', 'Wireless Air Marshal events', and 'Wireless Event log'. There are 'x' icons to remove roles and a trash icon to delete the server.

Step 4. Click **Save Changes**.

SNMP (device polling)

The SNMP device polling configuration is done at the network level.

Procedure 63. To configure SNMP device polling:

Step 1. Go to **Network-wide > Configure > General**.

Step 2. Under **Reporting** next to **SNMP access**, configure **V3 (username/password)**.

Step 3. Click **Add an SNMP user** and configure an **SNMP Username** and strong **Passphrase** that will be used for the authentication and privacy passwords.

Step 4. For **Privacy Mode**, select **AES128** (the Authentication Algorithm protocol will be SHA1).

SNMP access	V3 (username/passwords) ▾		
SNMP users	Username	Passphrase	
	snmpuser	Show secret ✕
	Add an SNMP user		
Authentication Algorithm	SHA ▾		
Privacy Mode	AES128 ▾		
When enabled, configure firewall settings for the SNMP service on the Firewall page.			

In this example, the SNMP server is in the data center and rules are already configured to allow the traffic in the outbound VPN firewall, so no further configuration is needed.

Step 5. Click **Save** or **Save Changes**.

NetFlow

This is configured at the network level.

Procedure 64. To configure NetFlow:

Step 1. Go to **Network-wide > Configure > General**.

Step 2. Under **Reporting** next to **NetFlow traffic reporting**, select **Enabled: send netflow traffic statistics**.

Step 3. Next to **NetFlow collector IP**, type the IP address of the NetFlow collector.

Step 4. Next to NetFlow collector port, type the port number of the NetFlow collector.

Step 5. Click **Save** or **Save Changes**.

NetFlow traffic reporting	Enabled: send netflow traffic statistics ▾
NetFlow collector IP	10.102.1.160
NetFlow collector port	2055

In this example, NetFlow is only enabled for the MX router since it is not supported on MS switches.

Organization: Configure Adaptive Policy

Adaptive Policy is enabled at the Organization level. When Adaptive Policy is enabled for a network, additional configuration options for adaptive policy appear in the MX site-to-site VPN configuration, MX port configurations, and switch port configurations.

Note: The C81xx series routers do not properly propagate SGT tags under certain software versions. This is fixed in MX version 26.1.4.

If groups and Adaptive Policy have already been defined, skip to the [Enable Networks for Adaptive Policy](#) section.

In this example, 4 groups are created which are all part of the DATA VLAN. Finance users can communicate with Finance servers and Marketing users but cannot reach Marketing servers. Marketing users can communicate with Marketing servers and Finance users but cannot reach Finance servers.

Procedure 65. To configure Adaptive Policy groups:

- Step 1.** On the dashboard, go to **Organization > Adaptive Policy**.
- Step 2.** Click the **Groups** tab. Click **+ Add group**.
- Step 3.** Configure a **Name** (Finance_User_Group), **SGT Value** (10), and **Description** (Finance User Group).
- Step 4.** Click **Create**.
- Step 5.** Repeat until the group configuration is complete.

Name	SGT value	Description
Finance_User_Group	10	Finance User Group
Marketing_User_Group	20	Marketing User Group
Finance_Server_Group	100	Finance Server Group
Marketing_Server_Group	200	Marketing Server Group

Adaptive Policy

Policies **Groups** Custom ACLs Networks

Q Search 6 results + Add group

<input type="checkbox"/>	Name	SGT Value	Description	Policy Objects	
<input type="checkbox"/>	Unknown	0	Created by Meraki, the Unknown group applies when a policy is specified for unsuccessful group classification	—	
<input type="checkbox"/>	Infrastructure	2	Created by Meraki, the Infrastructure group is used by Meraki devices for internal and dashboard communication	—	
<input type="checkbox"/>	Finance_User_Group	10	Finance User Group	—	
<input type="checkbox"/>	Marketing_User_Group	20	Marketing User Group	—	
<input type="checkbox"/>	Finance_Server_Group	100	Finance Server Group	—	
<input type="checkbox"/>	Marketing_Server_Group	200	Marketing Servers Group	—	

Rows per page 30 1-6 of 6 < 1 >

Traffic policies can now be created.

Procedure 66. To create Adaptive Policy traffic policies:

- Step 1.** On the **Adaptive Policy** page, click the **Policies** tab.

Step 2. Click **+ Add policies**.

Step 3. Under **Source groups**, select a **Name** (Finance_User_Group), then under **Destination groups**, select all groups that will be allowed (Finance_User_Group, Marketing_User_Group, and Finance_Server_Group).

Step 4. At the top of **Destination groups**, click **Allow**.

The screenshot shows two panels: 'Source groups' and 'Destination groups'. In the 'Source groups' panel, 'Finance_User_Group' is selected. In the 'Destination groups' panel, 'Unknown', 'Finance_User_Group', 'Marketing_User_Group', and 'Finance_Server_Group' are selected. The 'Allow' button is highlighted with a red box.

Source groups			
Name	SGT Value	Description	
Unknown	(0)	0 Created by Meraki, the Unknown group applies when a policy is specified for unsuccessful group classification	<input type="checkbox"/>
Infrastructure	(0)	2 Created by Meraki, the Infrastructure group is used by Meraki devices for internal and dashboard communication	<input type="checkbox"/>
Finance_User_Group	(0)	10 Finance User Group	<input checked="" type="checkbox"/>
Marketing_User_Group	(0)	20 Marketing User Group	<input type="checkbox"/>
Finance_Server_Group	(0)	100 Finance Server Group	<input type="checkbox"/>
Marketing_Server_Group	(0)	200 Marketing Server Group	<input type="checkbox"/>

Destination groups				
Name	Permission	SGT Value	Description	
Unknown	(0)	0	Created by Meraki, the Unknown group applies when a policy is specified for...	<input checked="" type="checkbox"/>
Infrastructure	(0)	2	Created by Meraki, the Infrastructure group is used by Meraki devices for...	<input type="checkbox"/>
Finance_User_Group	(0)	10	Finance User Group	<input checked="" type="checkbox"/>
Marketing_User_Group	(0)	20	Marketing User Group	<input checked="" type="checkbox"/>
Finance_Server_Group	(0)	100	Finance Server Group	<input checked="" type="checkbox"/>
Marketing_Server_Group	(0)	200	Marketing Server Group	<input type="checkbox"/>

Step 5. A window pops up and displays the changes. A box can be checked to automatically create the inverse policy. An error occurs if a reverse policy already exists. In this case, do not automatically create the inverse policy since Finance_User_Group → Finance_User_Group would attempt to be created twice, generating an error. Click **Allow**.

The dialog box titled 'Allow Policies' asks for confirmation to allow all traffic. It lists four policies: Finance_User_Group → Unknown, Finance_User_Group → Finance_User_Group, Finance_User_Group → Marketing_User_Group, and Finance_User_Group → Finance_Server_Group. It also includes a checkbox for 'Would you like to automatically create the inverse policy?' and 'Cancel' and 'Allow' buttons.

Allow Policies

Are you sure you want to allow all traffic:

1. Finance_User_Group → Unknown
2. Finance_User_Group → Finance_User_Group
3. Finance_User_Group → Marketing_User_Group
4. Finance_User_Group → Finance_Server_Group

Currently the policy is being configured in a single direction.

Would you like to automatically create the inverse policy?

Cancel Allow

Step 6. Continue adding policy, selecting **Allow** or **Deny** between groups.

Note: In this example, Unknown and Infrastructure groups are permitted to reach all other defined groups. This is so Finance and Marketing devices can ping their IP default gateways and perform other

troubleshooting and monitoring tasks.

Group	Unknown	Infra-structure	Finance_User_Group	Marketing_User_Group	Finance_Server_Group	Marketing_Server_Group
Unknown			Allow	Allow	Allow	Allow
Infrastructure			Allow	Allow	Allow	Allow
Finance_User_Group	Allow	Allow	Allow	Allow	Allow	Deny
Marketing_User_Group	Allow	Allow	Allow	Allow	Deny	Allow
Finance_Server_Group	Allow	Allow	Allow	Deny	Allow	Deny
Marketing_Server_Group	Allow	Allow	Deny	Allow	Deny	Allow

Step 7. View the resulting policy in grid format or list format, which can be selected in the upper right corner of the **Adaptive Policy** page:

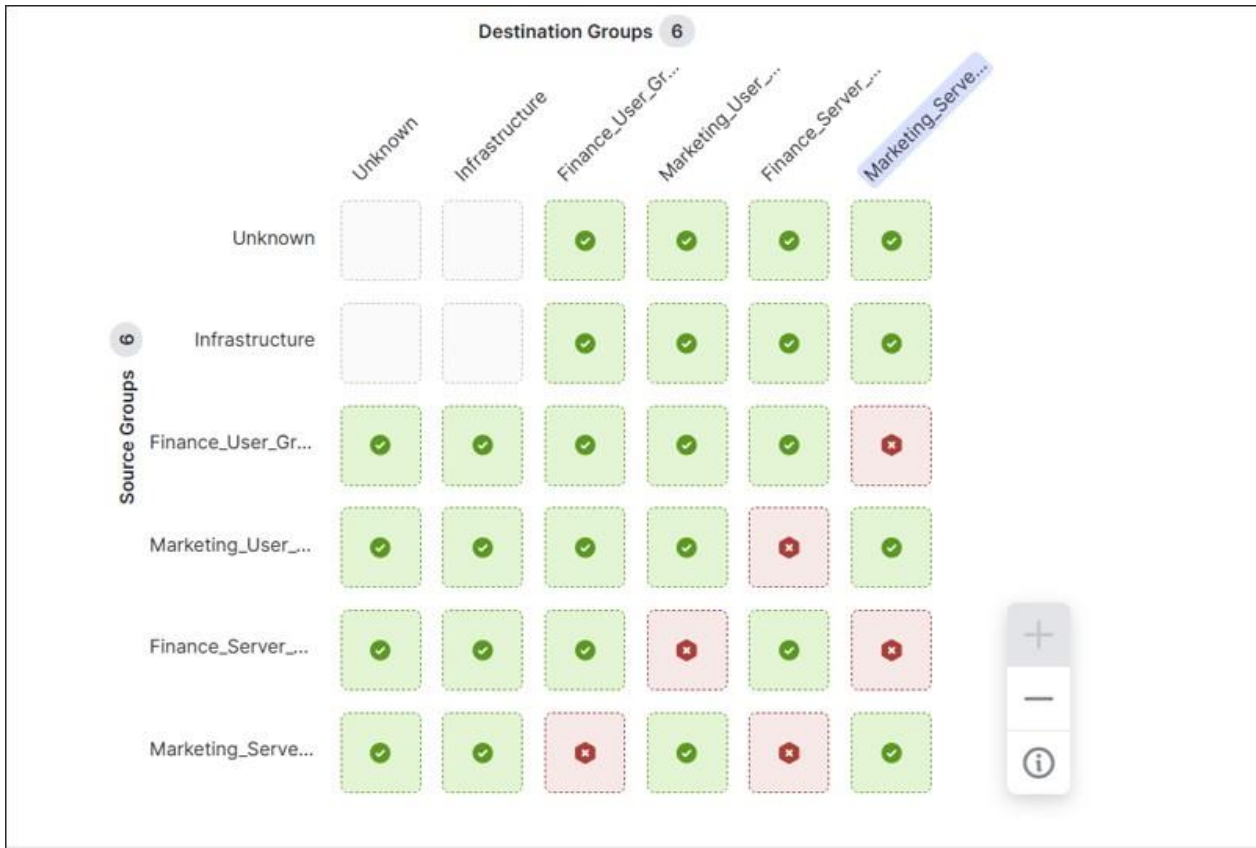

Enable networks for Adaptive Policy

Procedure 67. To enable Adaptive Policy in individual branches:

- Step 1.** Go to **Organization > Adaptive Policy** and click on the **Networks** tab.
- Step 2.** Select the branches that need to be enabled for Adaptive Policy then click **Enable**.
- Step 3.** Verify DC1 and DC2 hub sites are also enabled.

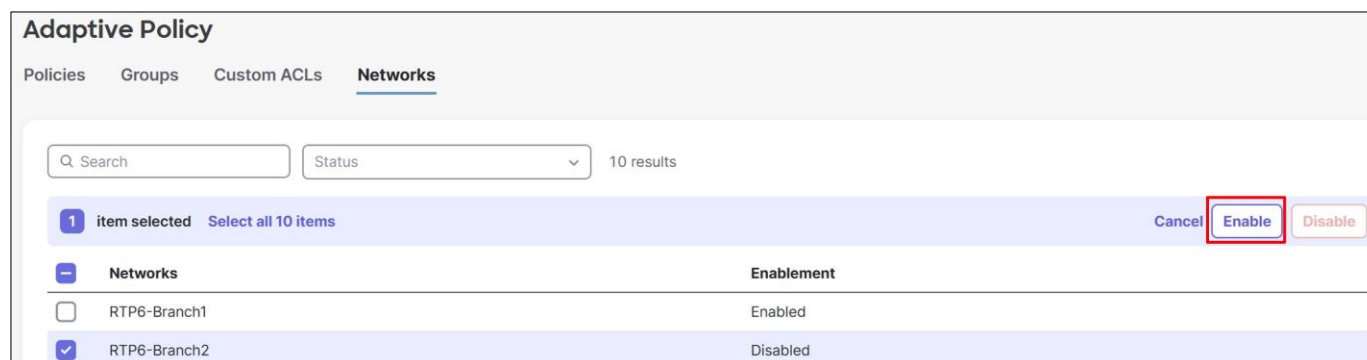

- Step 4.** A pop-up window may caution that making modifications to the Adaptive Policy on a network may cause a momentary disruption of all traffic due to SGT configuration changes. Click **Enable**.

RTP6-Branch2 is now enabled for the Adaptive Policy.

To ensure tags can be propagated from end-to-end, Auto VPN and trunk ports in the branches need to be enabled as “Peer SGT capable”. Assignment of SGTs in this example network is done through RADIUS when a client joins the network.

Auto VPN configuration

Procedure 68. To configure Adaptive Policy for Auto VPN:

- Step 1.** Go to **Network RTP6-Branch2**.
- Step 2.** Go to **Security & SD-WAN > Configure > Site-to-site VPN**.
- Step 3.** Under **VPN settings** next to **Peer SGT capable**, select **Enabled**.

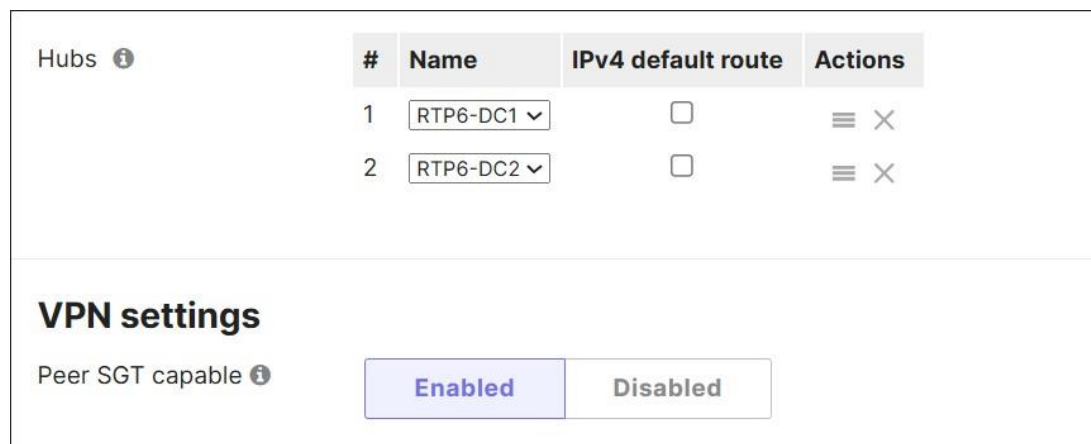

- Step 4.** Click **Save** or **Save Changes**.
- Step 5.** Repeat the configuration for sites that need SGT tag propagation over Auto VPN (DC1, DC2, and any other branch sites).

Both Auto VPN peers are now enabled to allow for SGT tag propagation. In the hub and spoke topology, the data center hubs need this configuration in order for SGT tags to be propagated from site to hub and from site to site.

LAN trunk configuration

Before SGT tags can be propagated to a neighbor on the LAN, the trunk port to that neighbor needs to be marked as Peer SGT capable.

Procedure 69. To configure Adaptive Policy for LAN trunks:

- Step 1.** For the MX router, go to **Security & SD-WAN > Configure > Addressing & VLANs**.
- Step 2.** Select the ports to the LAN switches (Ports 5 and 6 in this example) then click **Edit** at the top next to **Per-port VLAN Settings**.
- Step 3.** Next to **Peer SGT capable**, select **Enabled**.
- Step 4.** Next to **Adaptive policy**, from the drop-down menu, select a group (2: Infrastructure (Predefined)) to add to untagged traffic, which should be device management and dashboard traffic.
- Step 5.** Click **Update**.
- Step 6.** Click **Save**.

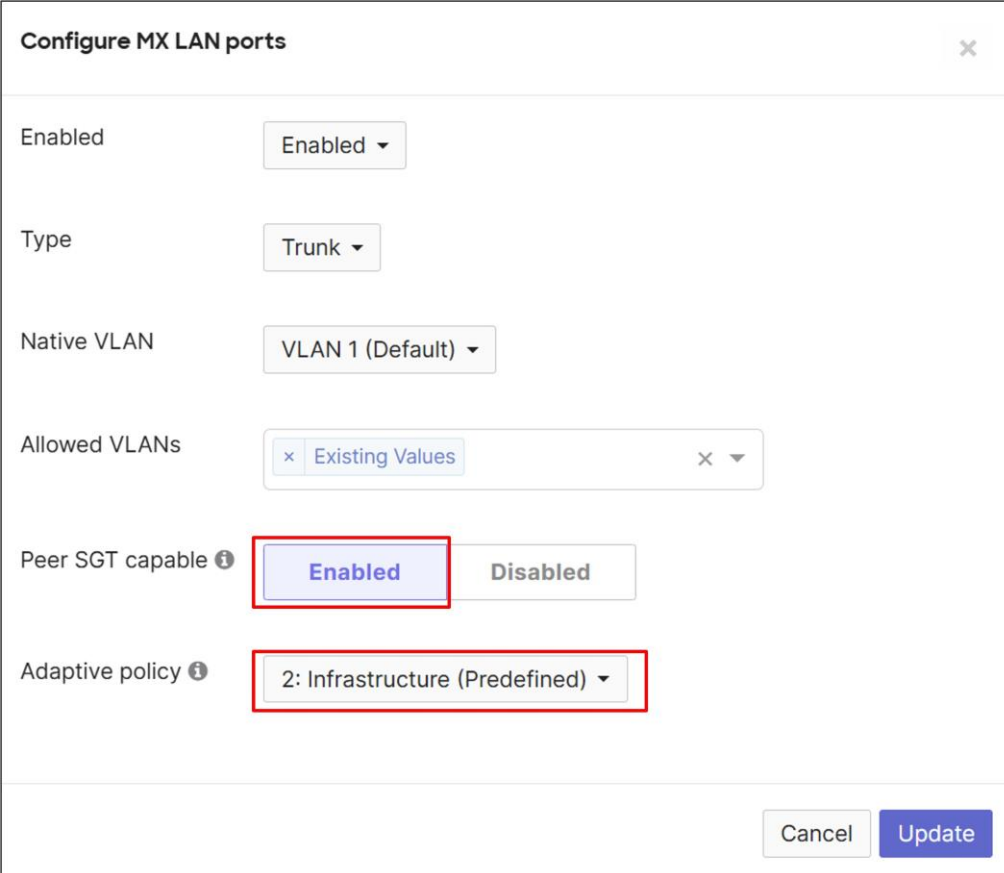

Configure MX LAN ports [X]

Enabled: Enabled ▾

Type: Trunk ▾

Native VLAN: VLAN 1 (Default) ▾

Allowed VLANs: Existing Values [X] ▾

Peer SGT capable ⓘ: **Enabled** Disabled

Adaptive policy ⓘ: **2: Infrastructure (Predefined)** ▾

Cancel Update

On the switches, the trunks to the MX routers and the trunk to the AP will both have to be marked as Peer SGT capable.

- Step 7.** Go to **Switching > Monitor > Switch Ports**.
- Step 8.** Select all uplink ports to the MX routers (B2-SW1/1, B2-SW1/2, B2-SW2/1, and B2-SW2/2) and the port to the AP (B2-SW1/9) and click **Edit**.
- Step 9.** Next to **Peer SGT capable**, click **Enabled**.
- Step 10.** Next to **Adaptive policy group**, select 2: Infrastructure from the drop-down menu.

Step 11. Click **Update**.

Peer SGT capable	<input checked="" type="radio"/> Enabled	<input type="radio"/> Disabled
Adaptive policy group	2: Infrastructure ✕ ▾	
RSTP	<input checked="" type="radio"/> Enabled	<input type="radio"/> Disabled

The AP automatically detects SGT tags coming from the switch and will then send SGT-tagged traffic, so no manual configuration is required on the AP.

Step 12. Repeat for other sites.

Organization configuration: ThousandEyes

ThousandEyes must be enabled on a network-by-network basis.

Procedure 70. To configure ThousandEyes integration:

Step 1. Go to **Insight > Configure > Active Application Monitoring**.

Step 2. If ThousandEyes has already been set up, a list of monitored networks appears. Follow these steps to continue:

- a. To add monitoring for another application or network, click the **Add tests** button.
- b. ThousandEyes shows as connected to a specific account group that was previously configured. Click **Next**.
- c. Skip to the [Application selection](#) section.

Step 3. If ThousandEyes has not been configured yet, click **Get started**.

Active Application Monitoring

Claim free **ThousandEyes** tests to monitor critical applications

- Instantly setup** ThousandEyes visibility at scale across all your Meraki WAN appliances.
- Find SaaS application issues before users** with continuous monitoring in ThousandEyes.
- Pinpoint issues with **end-to-end analysis** in **ThousandEyes dashboard**.

Coming soon

- View summarized application performance from ThousandEyes **directly in Meraki dashboard**.

Watch on YouTube

Get started

Step 4. Click **Authenticate** if you have an existing ThousandEyes account (or click **Create new account**). This example workflow assumes a ThousandEyes account already exists.

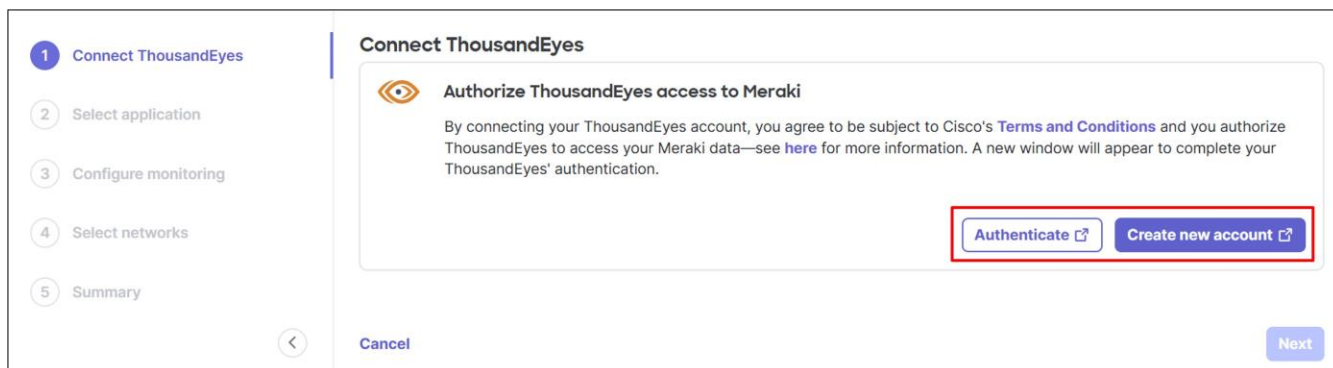

Step 5. After clicking **Authenticate**, a window pops up to log into Cisco ThousandEyes. Enter the email address and optional region. The region for ThousandEyes should be in the same region as Meraki. Click **Log In**.

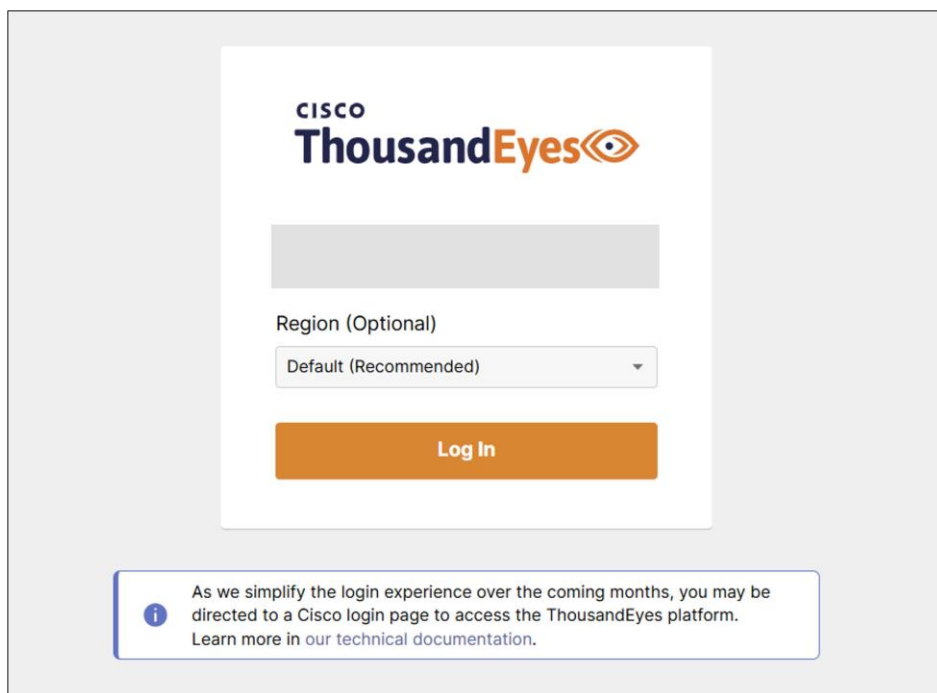

Step 6. In the next window, type in the password, then click **Next**.

Step 7. A window pops up explaining what Cisco Meraki is authorized to do when the integration is complete. Click **Confirm**.

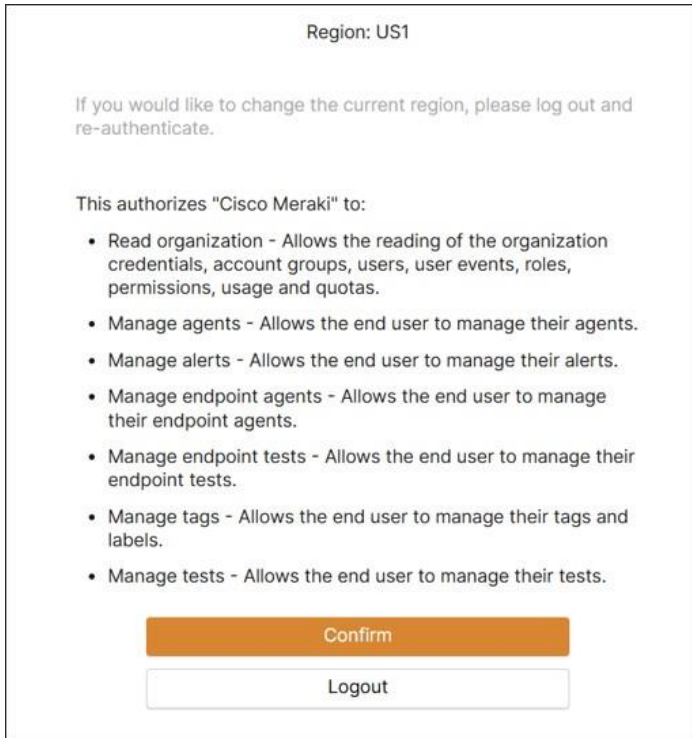

The authentication to ThousandEyes is now complete.

Step 8. Back on the Meraki Dashboard, select an account group from ThousandEyes from the drop-down menu to pair with Meraki and click **Confirm**.

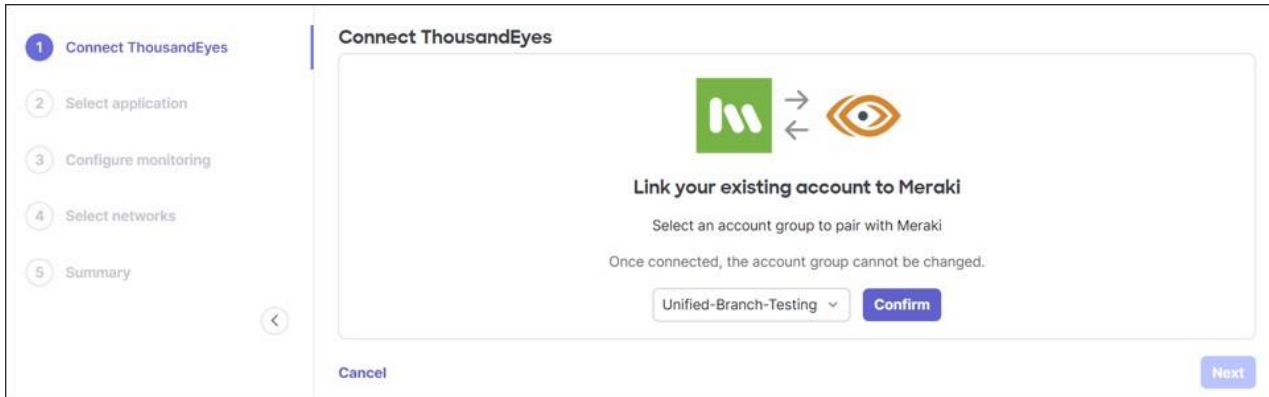

Step 9. The account group shows up as connected. Then click **Next**.

Application selection

In this example, Office 365 Suite is selected.

Procedure 71. To select an application to monitor:

Step 1. Select an application to monitor with enhanced application monitoring. Alternatively, add a custom application, or continue without an application for now.

Step 2. Click **Next**.

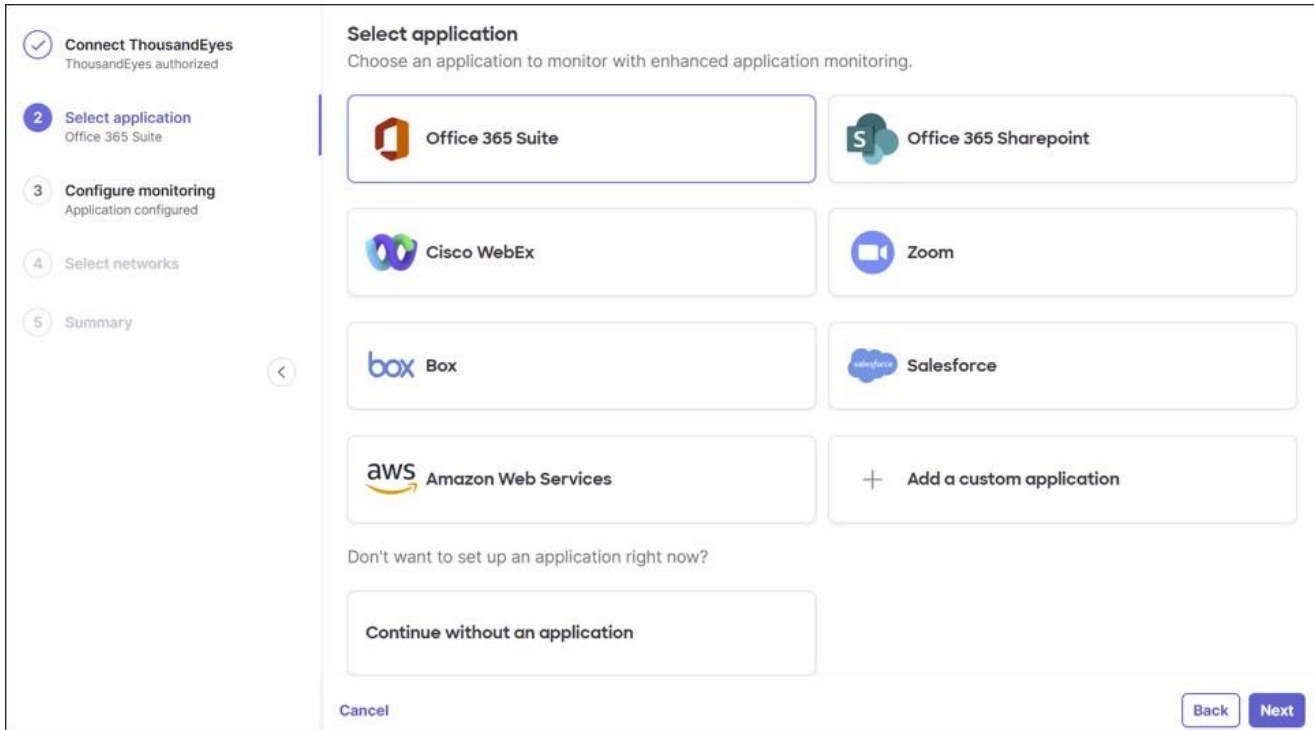

Network selection

In this example, **RTP6-Branch2** is selected.

Procedure 72. To select networks to activate ThousandEyes agents on:

Step 1. To run application tests, select the networks to activate ThousandEyes agents on, then click **Next**.

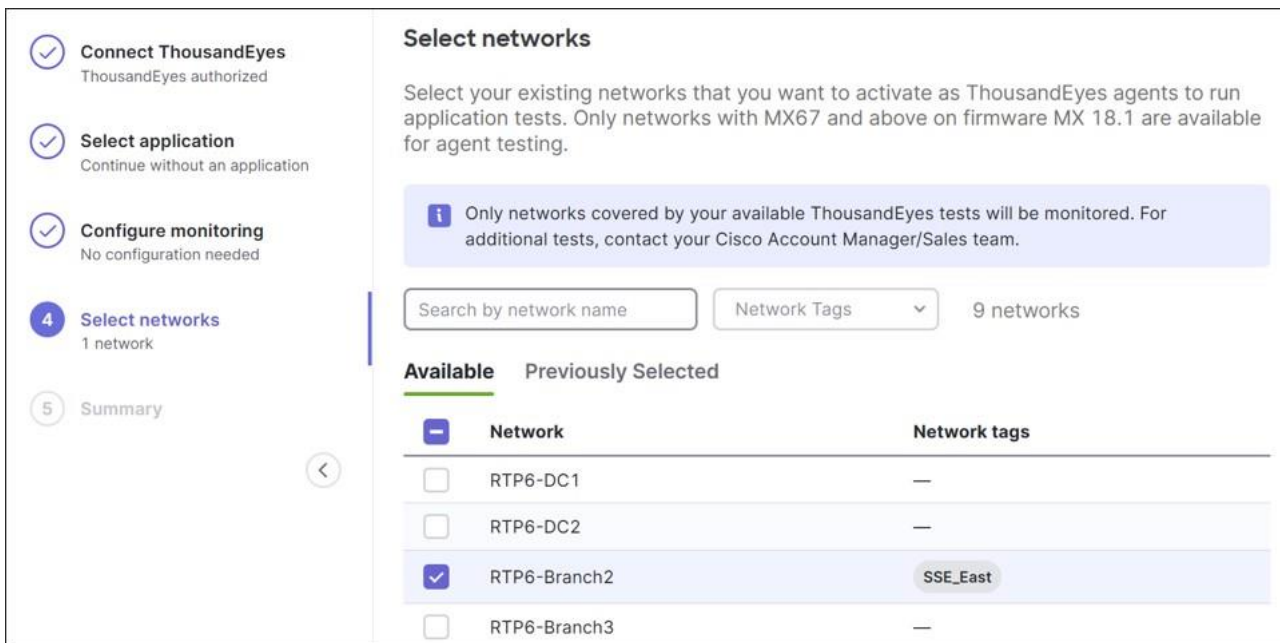

Step 2. Click **Start monitoring**.

Active Application Monitoring Get free tests

Powered by **ThousandEyes**

Monitored Networks Settings

Search by network name 2 matching results View applications Add tests

Monitored Networks	Location	Last contact	Applications	Enable	Remove
RTP6-Branch1 - appliance	North Carolina, US	Feb 27, 16:18	View	<input checked="" type="checkbox"/>	
RTP6-Branch2 - appliance	—	—	View	<input checked="" type="checkbox"/>	

Step 3. After a brief period of time, the monitored network shows active. Click **View applications** to go directly to the ThousandEyes dashboard.

Active Application Monitoring Get free tests

Powered by **ThousandEyes**

Monitored Networks Settings

Search by network name 2 matching results View applications Add tests

Monitored Networks	Location	Last contact	Applications	Enable	Remove
RTP6-Branch1 - appliance	North Carolina, US	Feb 27, 16:24	View	<input checked="" type="checkbox"/>	
RTP6-Branch2 - appliance	North Carolina, US	Feb 27, 16:24	View	<input checked="" type="checkbox"/>	

Step 4. Skip the prompts to set up monitoring by deploying templates. The agent can be seen from the ThousandEyes dashboard.

Event Detection

Alerts

Network & App Synthetics >

Routing >

Traffic Insights >

Agents Notifications Kerberos Settings

Assigned to Account Group **Unified-Br...** Add a filter

Search... 2 Enterprise Agents Add New Enterprise Agent

<input type="checkbox"/> Agent Name	Hostname	Utilization	Status/Last Contact
<input type="checkbox"/> RTP6-Branch1-1600829	m08F1B386A66E-1000000000	General 0%	1 minute ago
<input type="checkbox"/> RTP6-Branch2	m08F1B389C51F-1000000000	N/A	1 minute ago

Organization configuration: Splunk

Basic Splunk integration is at the Meraki organization level. If it is not already configured, follow these steps:

Procedure 73. To integrate Splunk:

Step 1. Before integrating the Meraki Dashboard Organization with Splunk, go to the Dashboard and retrieve the **Organization ID** and **Organization API Key**.

Step 2. On the Meraki Dashboard, go to the bottom of any page and record the organization ID.

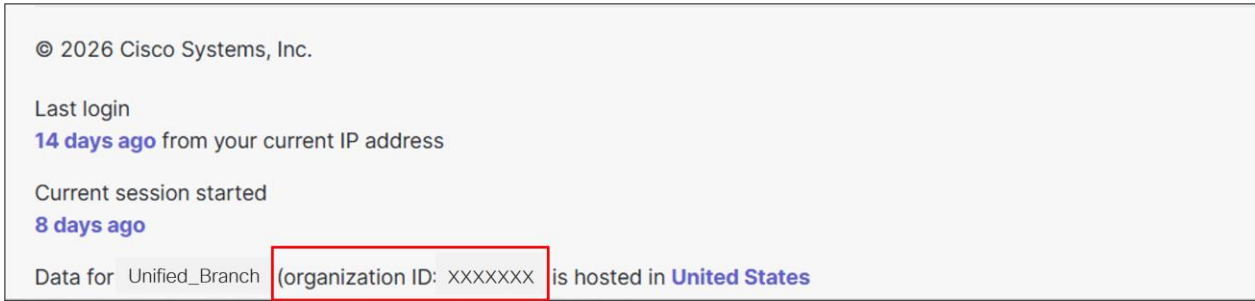

Step 3. To generate an API key, on the Meraki Dashboard, go to **Organization > Configure > API & Webhooks**, then go to the **API keys and access** tab.

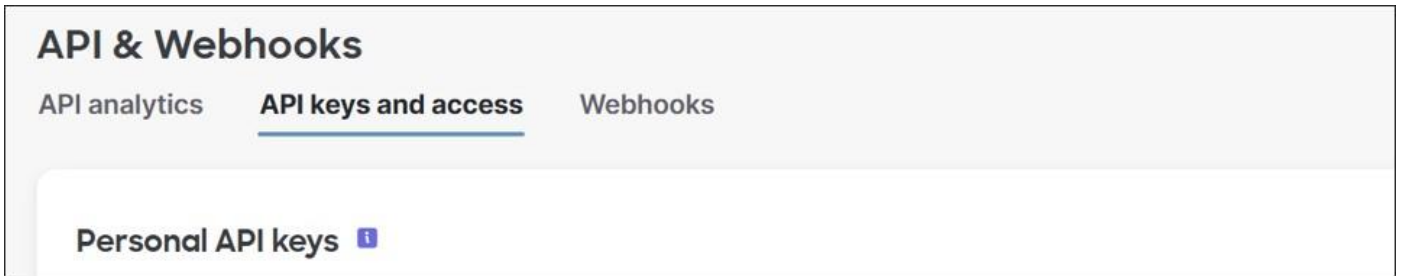

Step 4. Click **Generate API Key**. Copy the API key to use in the Splunk integration.

Note: The API key is generated, and this is the only chance to record it. If it is forgotten, it will need to be revoked and a new one generated.

Step 5. Select **I've stored my API key** and click **Done**.

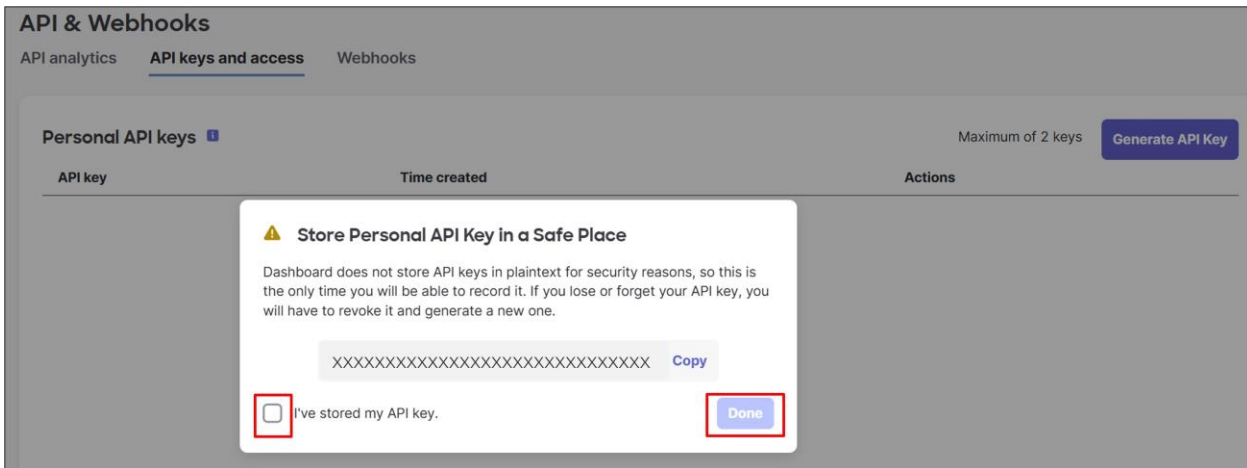

Step 6. Log into the Splunk dashboard.

Step 7. On the left-side, click **Splunk Add-on for Cisco Meraki**.

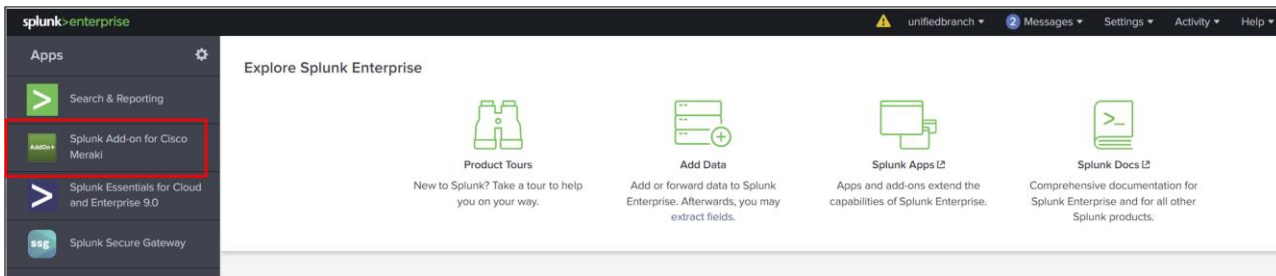

Step 8. Go to **Configuration > Organization** tab then click **Add**. In the pop-up window, enter values for these fields:

- **Organization Name:** <Enter a unique name> (Unified_Branch_CVD)
- **Service region:** <Choose a service region> Global (Meraki.com)
- **Organization ID:** <Enter the Organization ID found on the Meraki Dashboard>
- **Organization API Key:** <Enter the API Key created in the Meraki Dashboard>
- **Max API calls per second:** <Enter a value. It defaults to 5 calls per second> (5)
- **Create inputs* automatically?** <Click the box for yes> <yes>

*Inputs refer to the data sources that Splunk collects from Cisco Meraki devices and networks. These inputs allow users to monitor and analyze network data, including device status and alerts. If created automatically, all input types (except for webhook) are created in disabled mode.

Step 9. Click **Add**.

Add Organization [X]

* Organization Name:
Enter a unique name for this Meraki organization.

* Service region:
Select Service region (Global is preselected)

* Organization ID:
Enter Organization ID.

* Organization API Key:
Enter Organization API Key.

* Max API calls per second:
Enter maximum api calls per second for the Organization

Create inputs automatically?
Selecting this option will automatically create inputs for all input types (except Webhook) in disabled mode. The inputs will follow the default naming convention: <input_type>_<account_name>.

The Organization information is added to the Splunk Dashboard. Optionally, the logging level can be changed, or proxy information can be set up from this page.

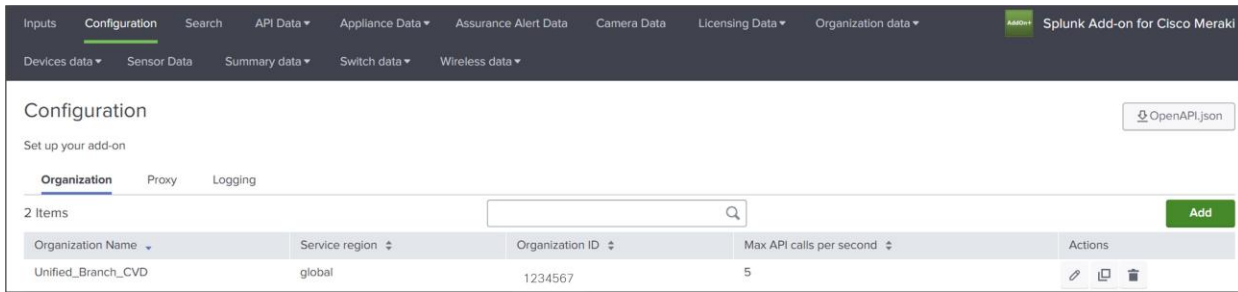

Step 10. To manage inputs, go to the **Inputs** tab on the Splunk dashboard and enable the ones of interest.

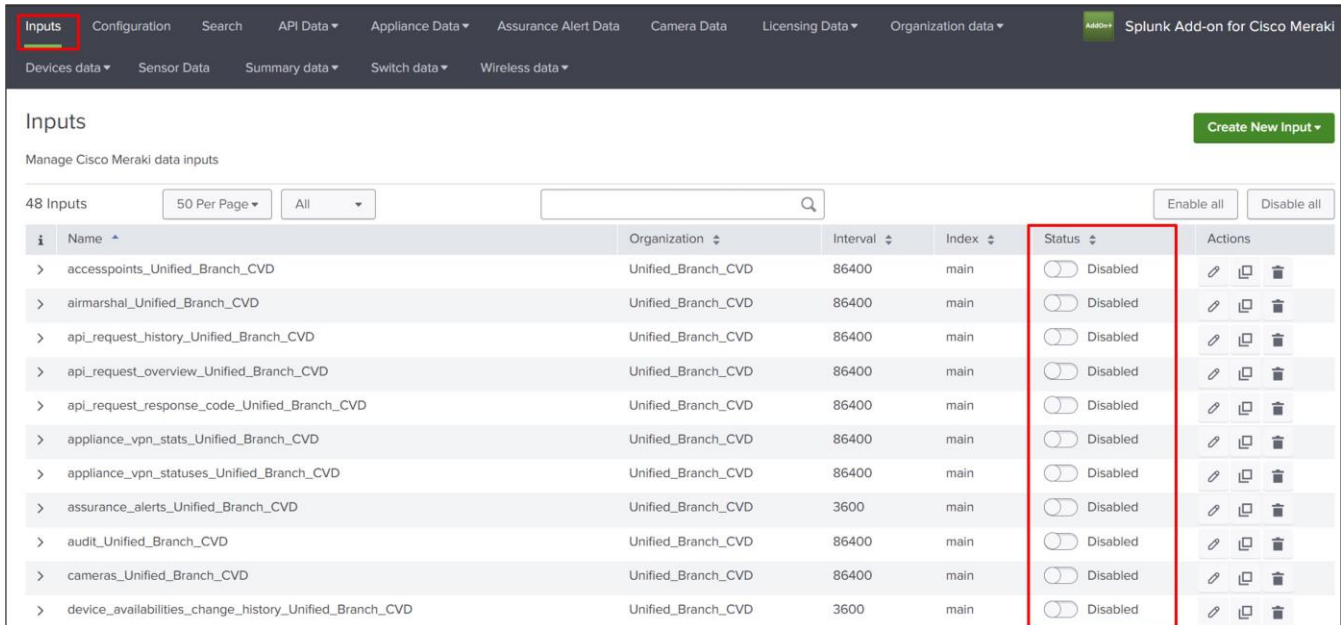

Webhooks can also be configured through the Dashboard for alerts on a network-by-network basis. Refer to [Cisco Meraki Add-on for Splunk](#) for additional information.

Organization configuration: XDR

The XDR integration to the Meraki Dashboard is performed once but is then enabled on a network-by-network basis. If XDR has already been integrated and is being enabled for additional networks, skip to the [Enable Networks for XDR](#) section.

Procedure 74. To integrate XDR:

- Step 1.** Go to **Organization > Configure > Integrations**.
- Step 2.** Select the **Cisco XDR** tile.

Integrations Browse Marketplace [↗](#)

Browse My integrations

Cisco Products
Innovate and integrate with Cisco products.

Catalyst SD-WAN

Connect to a Catalyst SD-WAN overlay to enable simple SD-WAN interconnects.

SD-WAN

Cisco XDR

Send flow telemetry to identify and prioritize security incidents.

Analytics

Cisco Spaces

Seamless Onboarding, Occupancy Analytics, Device Tracking & more.

Smart Spaces

Step 3. From this window, if an XDR account does not exist, click **Start a free trial**. This workflow assumes an XDR account already exists.

Step 4. Click **+Connect**.

← Integrations

Cisco XDR Start a free trial [↗](#) **+ Connect**

Description



Cisco XDR helps organizations quickly identify and respond to the most critical security incidents, reducing the time and effort required for threat investigation and remediation. It is a network-centric, cloud-based security extended detection and response (XDR) solution designed to simplify security operations and enhance threat detection and response capabilities. Cisco XDR integrates and correlates data from multiple security tools, including network, cloud, endpoint, email, applications, and identity, to provide a unified view of security threats. Through AI-driven analytics, it detects sophisticated threats, prioritizes incidents, and automates and guides responses to improve the efficiency and effectiveness of security practitioners and network administrators alike.

Developer Cisco

Category Network Security

Website cisco.com/go/xdr

Step 5. Select the region where the XDR organization account is provisioned, then click **Connect**.

← Integrations

Cisco XDR Start a free trial [↗](#)

Description

Connect to XDR

Select your region to integrate Cisco XDR.

 Please make sure you are choosing the same region that your XDR organization account is provisioned. [See documentation](#)

North America

Europe

Asia Pacific

Cancel **Connect**

The login is verified and XDR is now connected and integrated in the Meraki Dashboard.

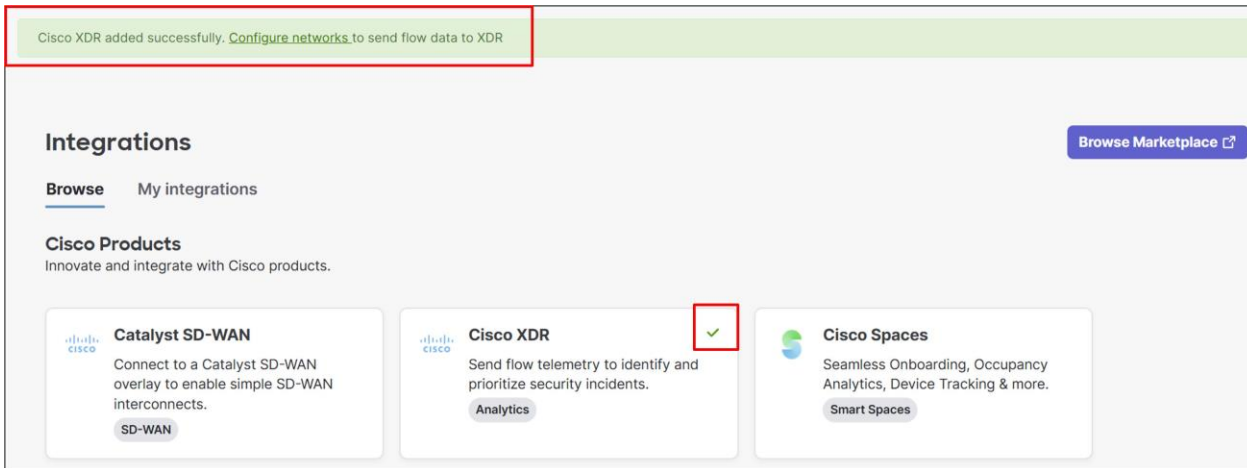

Step 6. View The Meraki Organization on the XDR dashboard under **Administration > Integrations**, in a list called **My Integrations**.

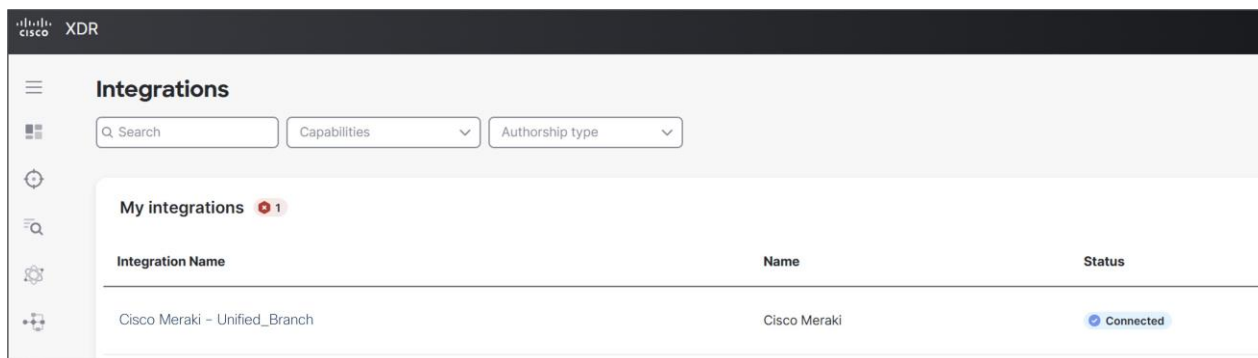

Enable networks for XDR

Procedure 75. To enable XDR for the network:

- Step 1.** Go to **Organization > Integrations**.
- Step 2.** Go to the **My integrations** tab.
- Step 3.** Click on the XDR integration with the Meraki Organization name.



Step 4. Select **Configure networks**.

← Integrations

Cisco XDR Connected

Description



Cisco XDR helps organizations quickly identify and respond to the most critical security incidents, reducing the time and effort required for threat investigation and remediation. It is a network-centric, cloud-based security extended detection and response (XDR) solution designed to simplify security operations and enhance threat detection and response capabilities. Cisco XDR integrates and correlates data from multiple security tools, including network, cloud, endpoint, email, applications, and identity, to provide a unified view of security threats. Through AI-driven analytics, it detects sophisticated threats, prioritizes incidents, and automates and guides responses to improve the efficiency and effectiveness of security practitioners and network administrators alike.

Developer Cisco

Category Network Security

Website cisco.com/go/xdr

Use this integration To send flow telemetry data to Cisco XDR: [Configure networks](#)

To view detailed XDR events, see also: [XDR Incidents](#)

Step 5. Click the check box for **RTP6-Branch2** to select it, then **Enable**.

Configure Networks

Select the networks to send flow telemetry to XDR. See [documentation on XDR](#)

Networks

Q Search Filters 10 networks Disable Enable

	Network	XDR status	Tags	XDR eligibility	Model	Firmware	License compliant
<input type="checkbox"/>	RTP6-DC1	Disabled		Eligible	MX105	MX 19.2.4	Compliant
<input type="checkbox"/>	RTP6-DC2	Disabled		Eligible	MX105	MX 19.2.4	Compliant
<input type="checkbox"/>	RTP6-Branch1	Enabled	SSE_East	Eligible	MX85	MX 19.2.4	Compliant
<input checked="" type="checkbox"/>	RTP6-Branch2	Disabled	SSE_East	Eligible	MX85	MX 19.2.7	Compliant
<input type="checkbox"/>	RTP6-Branch3	Disabled		Eligible	MX105	MX 19.1.11	Compliant

Step 6. A pop-up window asks to proceed with enabling XDR for RTP6-Branch2. Click **Enable**. The XDR status for Branch 2 now shows **Enabled**.

Configure Networks

Select the networks to send flow telemetry to XDR. See [documentation on XDR](#)

Networks

Q Search Filters 10 networks Disable Enable

<input type="checkbox"/>	Network	XDR status	Tags	XDR eligibility	Model	Firmware	License compliant
<input type="checkbox"/>	RTP6-DC1	Disabled		Eligible	MX105	MX 19.2.4	Compliant
<input type="checkbox"/>	RTP6-DC2	Disabled		Eligible	MX105	MX 19.2.4	Compliant
<input type="checkbox"/>	RTP6-Branch1	Enabled	SSE_East	Eligible	MX85	MX 19.2.4	Compliant
<input type="checkbox"/>	RTP6-Branch2	Enabled	SSE_East	Eligible	MX85	MX 19.2.7	Compliant

Data is now flowing to XDR.

Step 7. View XDR incidents from the Meraki Dashboard at **Organization > Monitor > Security Center** under the **XDR Incidents** tab.

Security Center

MX Summary **MX Events** **XDR Incidents** MR DNS Events

3 Incidents 3 New incidents 0 Open incidents 3 Unassigned incidents

Q Search Filters 3 matching results Configure networks

Priority	Name	Source	Created	Assigned	Status
450	Internal Port Scanner	Cisco XDR Analytics (org-7c94...	13 days	Unassigned	New
450	Internal Port Scanner	Cisco XDR Analytics (org-7c94...	13 days	Unassigned	New
450	Internal Port Scanner	Cisco XDR Analytics (org-7c94...	13 days	Unassigned	New

Verify device operation

Verify the operation of the devices using the dashboard.

Procedure 76. To verify device operation:

Step 1. Go to **Organization > Monitor > Overview** to get a big-picture view of the network. Only dashboard connectivity-related alerts are reflected on this page.

Map Satellite Address, zip code, etc. Go Hide table

Networks Network tags Devices

Tag Combine Delete Search... 9 networks Over the last week: 91 clients, 9.34 GB CSV +

<input type="checkbox"/>	Name	Usage	Clients	Tags	Network type	Devices	Offline devices
<input type="checkbox"/>	RTP6-Branch1	834.1 MB	10	SSE_East	Combined	3	0
<input type="checkbox"/>	RTP6-Branch4	590.4 MB	3		Combined	3	0
<input type="checkbox"/>	RTP6-Branch5	248.3 MB	2		Combined	2	0

Step 2. Go to **Organization > Monitor > Summary** to get a more granular view of the device and uplink status for each network.

Organization Summary

Devices

[View all devices](#)

Uplinks 25 total

4

Offline ✖

WAN Appliances 13 total

1

Offline ✖

Switches 14 total

All

Online ✔

Access Points 5 total

All

Online ✔

Networks

⊖ Usage and clients over the last week

Filters 10 results

<input type="checkbox"/>		Name ↕	Usage	Clients	Tags	WAN Appliances	Switches	Access Points
<input type="checkbox"/>	✔	RTP6-Branch1	821.7 MB	12	SSE_East	✔ 1	✔ 1	✔ 1
<input type="checkbox"/>	✔	RTP6-Branch11	576.2 MB	7	—	✔ 1	✔ 1	✔ 1
<input type="checkbox"/>	✔	RTP6-Branch13	11.41 GB	3	—	✔ 2	✔ 4	—

Step 3. Go to **Organization > Monitor > Alerts** to find additional alerts for the Organization.

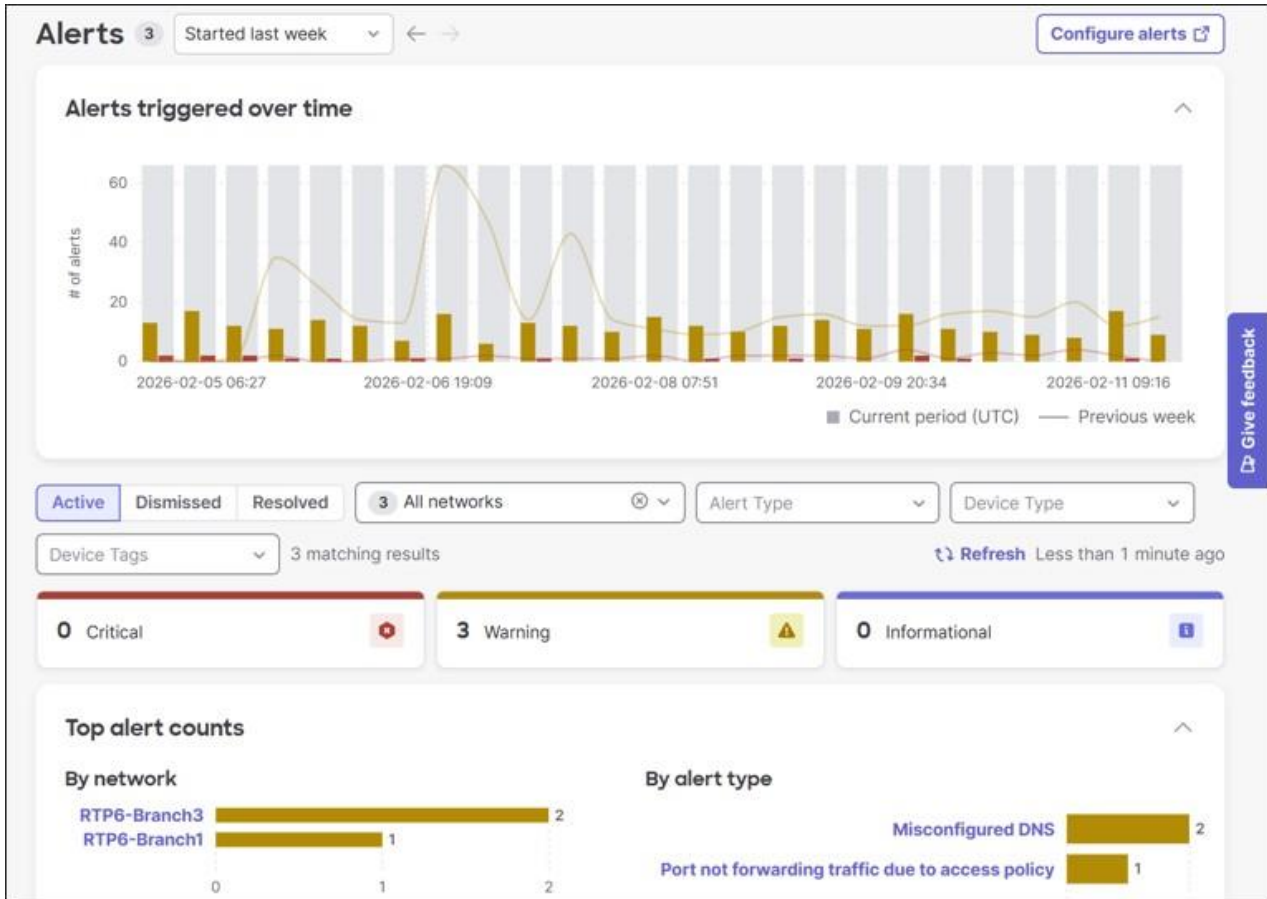

Procedure 77. To view an individual network:

- Step 1.** On the left of the dashboard (RTP6-Branch2), select the preferred **Network**.
- Step 2.** Select **Network-wide > Monitor > Clients**.
- Step 3.** Drill into any devices to review status, configurations, or troubleshoot issues. View clients connected to the network on this page as well.



- Step 4.** View network-wide events by going to **Network-wide > Monitor > Event Log** and selecting the device type to view.

Event log for switches ▾

Switch: Any Client: Any Before: 02/11/2026 13:54 (EST)

Event type include: All Event type ignore: None

Search [Reset filters](#)

Download as ▾ [« Newer](#) [Older »](#)

Time (EST) ▾	Switch	Switch port	Client	Category	Event type	Details
Feb 11 18:53:09	B1-SW1		ubuntu-vm	RADIUS	RADIUS authentication	resp: reject
Feb 11 18:53:09	B1-SW1	Port 24	ubuntu-vm	802.1X	802.1X deauthentication	port: 24

Procedure 78. To view IPsec tunnel status for Cisco Secure Access:

- Step 1.** Select the network and go to **Security & SD-WAN > Monitor > VPN Status**.
- Step 2.** Click the **IPsec peers** tab.
- Step 3.** Click **Details** for tunnel monitoring information.

VPN Status: **RTP6-Branch1 - appliance** for the last day ▾ [View old version](#)

Overview VPN participants

VPN Registry Connectivity

Usage

Latency

2 site-to-site peers 5 exported subnets **2 IPsec peers**

Status ▾	Name	Public IP	Subnets	Tunnel monitor	+
● IPsec	Unified_Branch_East_Primary	35.171.214.188	0.0.0.0/0	Details	
● Health check					
● IPsec	Unified_Branch_East_Secondary	44.217.195.188	0.0.0.0/0	Details	
● Health check					
2 total					

VPN Registry: Connected. This security appliance is able to connect to multiple VPN registries using UDP port 9352.

NAT type: Friendly. This security appliance is behind a VPN-friendly NAT, locally using 144.254.100.152:45979, which is NAT-ed to 64.102.251.42:45979

Encrypted. Using IPsec and AES encryption.

Step 4. For security events and incidents, go to **Organization > Monitor > Security Center**, where MX events and XDR incidents can be viewed.

For more information, refer to the Meraki [Security Center](#) documentation.

Appendix A: Hardware and software versions used

Hardware	Software
2x MX85	MX 19.2.7
2x MS150-24P-4G stack	MS 17.2.2
1x CW9172I	MR 31.1.8

Appendix B: Example deployment settings

This appendix summarizes the configurations used in this example deployment. If a setting is not mentioned, the default has been taken. Some of the example values may use default values.

Organization settings

On the dashboard under **Organization > Configure**

Main menu	Section	Subsection	Values
Adaptive Policy	Groups	Name/SGT Value/Description	Finance_User_Group/10/Finance User Group Marketing_User_Group/20/Marketing User Group Finance_Server_Group/100/Finance Server Group Marketing_Server_Group/200/Marketing Server Group
Adaptive Policy	Networks	Networks/Enablement	RTP6-Branch2/Enabled RTP6-DC1/Enabled RTP6-DC2/Enabled
Adaptive Policy	Policies	Source/Dest/Permission	Unknown/Finance_User_Group/Allow Unknown/Marketing_User_Group/Allow Unknown/Finance_Server_Group/Allow Unknown/Marketing_Server_Group/Allow Infrastructure/Finance_User_Group/Allow Infrastructure/Marketing_User_Group/Allow Infrastructure/Finance_Server_Group/Allow Infrastructure/Marketing_Server_Group/Allow Finance_User_Group/Finance_User_Group/Allow Finance_User_Group/Marketing_User_Group/Allow Finance_User_Group/Finance_Server_Group/Allow Finance_User_Group/Marketing_Server_Group/Deny Finance_User_Group/Unknown/Allow Finance_User_Group/Infrastructure/Allow Marketing_User_Group/Finance_User_Group/Allow Marketing_User_Group/Marketing_User_Group/Allow Marketing_User_Group/Marketing_Server_Group/Allow Marketing_User_Group/Finance_Server_Group/Deny Marketing_User_Group/Unknown/Allow Marketing_User_Group/Infrastructure/Allow Finance_Server_Group/Finance_User_Group/Allow Finance_Server_Group/Finance_Server_Group/Allow Finance_Server_Group/Unknown/Allow

Main menu	Section	Subsection	Values
			Finance_Server_Group/Infrastructure/Allow Finance_Server_Group/Marketing_User_Group/Deny Finance_Server_Group/Marketing_Server_Group/Deny Marketing_Server_Group/Finance_User_Group/Deny Marketing_Server_Group/Finance_Server_Group/Deny Marketing_Server_Group/Marketing_User_Group/Allow Marketing_Server_Group/Marketing_Server_Group/Allow Marketing_Server_Group/Unknown/Allow Marketing_Server_Group/Infrastructure/Allow
Settings	SNMP	Version 2C Version 3 Authentication mode Authentication password Privacy mode Privacy password IP restrictions	SNMP V2C disable SNMP V3 enabled SHA <passphrase> AES128 <passphrase> <IP address>
Policy Objects	All objects	Corp SNMP Corp DNS-DHCP Corp Mgt Corp RADIUS	10.102.1.161 10.102.1.160 10.102.1.160 10.102.1.157
Policy Objects	All objects	DATA Subnet Default Subnet GUEST Subnet INFRA Subnet IOT Subnet PCI Subnet VOICE Subnet	10.10.0.0/16 192.168.128.0/24 172.16.99.0/24 10.250.0.0/16 10.30.0.0/16 10.40.0.0/16 10.20.0.0/16
Policy Objects	All objects	Branch 2 Printer 1 Branch 2 Printer 2	10.30.2.101 10.30.2.102
Policy Objects	Groups	Corp Shared Services Branch 2 Printers	Corp DNS-DHCP, CORP RADIUS, Corp Mgt, Corp SNMP Branch 2 Printer 1, Branch 2 Printer 2

On the dashboard under **Organization > Monitor**

Main Menu	Section	Subsection	Values
Overview	RTP6-Branch2	Tag	SSE_East

Network-side settings

On the dashboard under **Network-wide > Configure**

Main menu	Section	Subsection	Values
General	General	Network name	RTP6-Branch2
General	General	Local time zone	America - New York (UTC -4.0, DST)
General	Traffic analysis	Traffic analysis	Detailed: collect destination hostnames
General	Device configuration	Local credentials	<Password>
General	Reporting	Syslog servers	10.102.1.160, port 514, Appliance Event log, Appliance Security events, Switch Event log, Wireless Air Marshal events, Wireless Event log
General	Reporting (SNMP Device Polling)	SNMP access SNMP users Authentication Algorithm Privacy Mode	V3 (username/passwords) Username: snmpuser/Passphrase: <passphrase> SHA AES128
General	Reporting	Network traffic reporting NetFlow collector IP NetFlow collector port	Enabled: send netflow traffic statistics 10.102.1.160 2055
Alerts	Alerts Settings	Default recipients	snmp
Alerts	Alerts Settings	Network-wide WAN appliance	A rogue access point is detected Malware is downloaded
Alerts	SNMP traps	Access Users Receiving server IP Receiving server port	V3 (username/password) Username: snmpuser, Passphrase: <passphrase> <IP address> 162
Group policies	DATA	Adaptive Policy SGT	Do not assign SGT
Group policies	DATA	Wireless only/VLAN	Tag VLAN 10
Group policies	VOICE	Adaptive Policy SGT	Do not assign SGT
Group policies	VOICE	Wireless only/VLAN	Tag VLAN 20
Group policies	IOT	Adaptive Policy SGT	Do not assign SGT
Group policies	IOT	Wireless only/VLAN	Tag VLAN 30
Group policies	PCI	Adaptive Policy SGT	Do not assign SGT
Group policies	PCI	Wireless only/VLAN	Tag VLAN 40

Cisco Secure Access settings

From the <https://sse.cisco.com> > Connect > Essentials > Network Connections > Network Tunnel Groups tab

Main menu	Section	Subsection	Values
Network Tunnel Groups	General Settings	Tunnel Group Name Region Device Type	UnifiedBranchEast <Region> Meraki MX
	Tunnel ID and Passphrase	Tunnel ID Passphrase Confirm Passphrase	UnifiedBranchEast@<org><hub>.sse.cisco.com <Cisco Secure Access Passphrase> <Cisco Secure Access Passphrase>
	Routing	Network Address Translation (NAT)	Enable NAT/Outbound only

MX router settings

On the dashboard under **Security & SD-WAN > Monitor**

Main menu	Section	Subsection	Values
Appliance Status	Summary	Appliance name (top left, edit mac address)	B2-MX1
		Address	<Location>
		SPARE (edit)	Uplink IPs: Use virtual uplink IPs WAN 1 shared IP (x.x.x.x) (unique IP address part of WAN 1 subnet) WAN 2 shared IP (x.x.x.x) (unique IP address part of WAN 2 subnet)
Spare Status	Summary	Appliance name (top left, edit mac address)	B2-MX2

On the dashboard under **Security & SD-WAN > Configure**

Main menu	Section	Subsection	Values
Site-to-site VPN	Site-to-site VPN	Type	Spoke
Site-to-site VPN	Site-to-site VPN	Hubs	RTP6-DC1 RTP6-DC2
Site-to-site VPN	VPN settings	Peer SGT capable	Enabled
Site-to-site VPN	Organization-wide settings	IPsec Peers>Configure Health checks	<ul style="list-style-type: none"> Health check: SSE Endpoint: http://service.sig.umbrella.com
Site-to-site VPN	Organization-wide settings	IPsec Peers>Add a Peer	<ul style="list-style-type: none"> Name: Unified_Branch_East_Primary IKE version: IKEv2 Peers>Public IP or Hostname: <Cisco Secure Access Primary IP>

Main menu	Section	Subsection	Values
			<ul style="list-style-type: none"> • Peers>Local ID: <Cisco Secure Access Primary Tunnel Group ID> • Peers>Shared secret: <Cisco Secure Access Passphrase> • Peers>Routing: Static • Peers>Private subnets: 0.0.0.0/0 • Peers>Availability: SSE_East • Multi-Uplink IPsec VPN: Enable • Tunnel monitoring>Health check: SSE • IPsec policy>Preset: Umbrella
Site-to-site VPN	Organization-wide settings	IPsec Peers>Unified_Branch_East_Primary>Add secondary peer	<ul style="list-style-type: none"> • Inherit primary peer configurations • Name: Unified_Branch_East_Secondary • Peers>Public IP or Hostname: <Cisco Secure Access Secondary IP> • Peers>Local ID: <Cisco Secure Access Secondary Tunnel Group ID>
Addressing & VLANs	Deployment Settings	Mode	Routed
Addressing & VLANs	Routing	LAN Setting	VLANs
Addressing & VLANs	Routing	Subnets	<ul style="list-style-type: none"> • 999, INFRA, 10.250.2.1/24, VPN mode = Enabled • 50, GUEST, 172.16.99.1/24, VPN mode = Disabled • 40, PCI, 10.40.2.1/24, VPN mode = Enabled • 30, IOT, 10.30.2.1/24, VPN mode = Enabled • 20, VOICE, 10.20.2.1/24, VPN mode = Enabled • 10, DATA, 10.10.2.1/24, VPN mode = Enabled • 1, Default, 192.168.128.1/24, VPN mode = Disabled
Addressing & VLANs	Routing	Per-port VLAN Settings	<ul style="list-style-type: none"> • Ports 5 & 6 Enabled, Type Trunk, Native VLAN 1, Allowed VLANs = 1,10,20,30,40,50,999, Peer SGT Capable = Enabled, Adaptive Policy - 2: Infrastructure (Predefined) • Ports 7-14 Disabled
DHCP	VLAN 1 (Default)	Client addressing Mandatory DHCP DNS nameservers	Run a DHCP server Enabled Use OpenDNS
DHCP	VLAN 10 (DATA)	Client addressing DHCP server IPs Mandatory DHCP	Relay DHCP to another server 10.102.1.160 10.102.1.161 Disabled
DHCP	VLAN 20 (VOICE)	Client addressing DHCP server IPs Mandatory DHCP	Relay DHCP to another server 10.102.1.160 10.102.1.161 Disabled
DHCP	VLAN 30 (IOT)	Client addressing DHCP server IPs Mandatory DHCP	Relay DHCP to another server 10.102.1.160 10.102.1.161 Disabled
DHCP	VLAN 40 (PCI)	Client addressing	Relay DHCP to another server

Main menu	Section	Subsection	Values
		DHCP server IPs	10.102.1.160 10.102.1.161
		Mandatory DHCP	Disabled
DHCP	VLAN 50 (GUEST)	Client addressing	Run a DHCP server
		Mandatory DHCP	Enabled
		DNS nameservers	Use OpenDNS
DHCP	VLAN 999 (INFRA)	Client addressing	Run a DHCP server
		Mandatory DHCP	Disabled
		DNS nameservers	Specify nameservers
		Reserved IP ranges	<Any IOS XE switch stack Mgt IP addresses set manually>
		Custom nameservers	10.102.1.160 10.102.1.161
		Fixed IP assignments	B2-SW1, 6c:c3:b2:7f:a7:40, 10.250.2.11 B2-SW2, 5c:06:10:5f:67:2e, 10.250.2.12 B2-AP1, cc:6e:2a:d8:9b:10, 10.250.2.21
Site-to-site VPN	Organization-wide settings	Site-to-site outbound firewall	<ul style="list-style-type: none"> • Shared Services: Allow prot:Any Src:[DATA Subnet, IOT Subnet, VOICE Subnet, INFRA Subnet, PCI Subnet] Any Dest:Corp Shared Services Any • Shared Services: Allow prot:Any Src:Corp Shared Services Any Dest:[DATA Subnet, IOT Subnet, VOICE Subnet, INFRA Subnet, PCI Subnet] Any • Data Access: Deny prot:Any Src:DATA Subnet Any Dest:[IOT Subnet, VOICE Subnet, INFRA Subnet, PCI Subnet] Any • IOT Access: Deny prot:Any Src:IOT Subnet Any Dest:[DATA Subnet, INFRA Subnet, VOICE Subnet, PCI Subnet] Any • Infra Access: Deny prot:Any Src:INFRA Subnet Any Dest:[DATA Subnet, IOT Subnet, VOICE Subnet, PCI Subnet] Any • Voice Access: Deny prot:Any Src:Voice Subnet Any Dest:[IOT Subnet, INFRA Subnet, DATA Subnet, PCI Subnet] Any • PCI Access: Deny prot:Any Src:PCI Subnet Any Dest:[DATA Subnet, IOT Subnet, VOICE Subnet, INFRA Subnet] Any • Default rule: Allow prot:Any Src:Any Any Dest:Any Any
Firewall	Layer 3	Outbound rules	<ul style="list-style-type: none"> • Local Print Access: Allow prot:Any Src:[DATA Subnet] Any Dest:[Branch 2 Printers] Any • Default (VLAN 1) Access: Deny prot:Any Src:Default Subnet Any Dest:[DATA Subnet, VOICE Subnet, IOT Subnet, PCI Subnet, GUEST Subnet, INFRA Subnet] Any • Data Access: Deny prot:Any Src:DATA Subnet Any Dest:[Default Subnet, VOICE Subnet, IOT Subnet, PCI Subnet, GUEST Subnet, INFRA Subnet] Any • IOT Access: Deny prot:Any Src:IOT Subnet Any Dest:[Default Subnet, DATA Subnet, VOICE Subnet, PCI Subnet, GUEST Subnet, INFRA Subnet] Any • Infra Access: Deny prot:Any Src:INFRA Subnet Any Dest:[Default Subnet, DATA Subnet, VOICE Subnet, IOT Subnet, PCI Subnet, GUEST Subnet] Any • Voice Access: Deny prot:Any Src:Voice Subnet Any Dest:[Default Subnet, DATA Subnet, IOT Subnet, PCI Subnet, GUEST Subnet, INFRA Subnet] Any • PCI Access: Deny prot:Any Src:PCI Subnet Any Dest:[Default Subnet, DATA Subnet, VOICE Subnet, IOT Subnet, GUEST Subnet,

Main menu	Section	Subsection	Values
			INFRA Subnet] Any <ul style="list-style-type: none"> • Guest Access: Deny prot:Any Src:GUEST Subnet Any Dest:[Default Subnet, DATA Subnet, VOICE Subnet, IOT Subnet, PCI Subnet, INFRA Subnet] Any • Allow Direct Internet Access: Allow prot:Any Src:[INFRA Subnet, DATA Subnet, GUEST Subnet, Default Subnet] Any Dest:Any Any • Deny All: Deny prot:Any Src:Any Any Dest: Any Any • Default Rule: Allow prot:Any Src: Any Any Dest: Any Any
Firewall	Layer 3	WAN appliance services	ICMP Any, Web None, SNMP None
SD-WAN & traffic shaping	Uplink configuration	WAN 1	400 Mbps
SD-WAN & traffic shaping	Uplink configuration	WAN 2	500 up/500 down
SD-WAN & traffic shaping	Uplink selection	Load balancing	Disabled
SD-WAN & traffic shaping	Uplink selection	Multi-Uplink AutoVPN	Enabled
SD-WAN & traffic shaping	SD-WAN policies	Custom performance classes	<ul style="list-style-type: none"> • SaaS_Traffic, 150, 50, 5 • Critical_Apps, 150, 20. 2 • Default_SLA, (none), 100, 5
SD-WAN & traffic shaping	SD-WAN policies	Internet traffic	<ul style="list-style-type: none"> • Prefer WAN 2. Fail over if uplink down • 10.250.0.0/24:any to any:any
SD-WAN & traffic shaping	SD-WAN policies	Internet traffic	<ul style="list-style-type: none"> • Prefer WAN 2. Fail over if poor performance for SaaS_Traffic • 10.10.0.0/24 to Office 365 or Webex
SD-WAN & traffic shaping	SD-WAN policies	VPN traffic	<ul style="list-style-type: none"> • Prefer WAN 2. Fail over if poor performance for VoIP • All VoIP & Video conferencing
SD-WAN & traffic shaping	SD-WAN policies	VPN traffic	<ul style="list-style-type: none"> • Prefer WAN 2. Fail over if poor performance for “Critical_Apps” • TCP from Any to 10.102.1.161/32:443
SD-WAN & traffic shaping	SD-WAN policies	VPN traffic	<ul style="list-style-type: none"> • Prefer WAN 1. Fail over if poor performance for “Default_SLA” • Any to Any
SD-WAN & traffic shaping	Local internet breakout	VPN exclusion rules	<ul style="list-style-type: none"> • Office 365 Suite • Webex • Layer 3 udp from Any to 64.62.142.12/32 • Layer 3 Any from Any to 158.115.128.0/19 • Layer 3 Any from Any to 209.206.48.0 • Layer 3 Any from Any to 216.157.128.0/20
SD-WAN & traffic shaping	Global bandwidth limits	Per-client limit	unlimited
SD-WAN & traffic shaping	Traffic shaping rules	Default Rules	Enable default traffic shaping rules

Main menu	Section	Subsection	Values
SD-WAN & traffic shaping	Traffic shaping rules	Rule #1	<ul style="list-style-type: none"> Definition: localnet 172.16.99.0/24 Bandwidth limit: Ignore network per-client limit (unlimited) Priority: Low DSCP tagging: 0 (CS0/DF - Best Effort/Default Forwarding)
SD-WAN & traffic shaping	Traffic shaping rules	Rule #2	<ul style="list-style-type: none"> Definition: net/port 10.102.1.161/32 Bandwidth limit: Ignore network per-client limit (unlimited) Priority: High DSCP tagging: 18 (AF21 - Low Latency Data, Low Drop)
Threat Protection	Advanced Malware Protection (AMP)	Mode	Enabled
Threat Protection	Intrusion detection and prevention	Mode Ruleset	Prevention Balanced
Content Filtering	Category blocking	Content categories	Adult, Hate Speech, Illegal Activities, Illegal Drugs, Pornography, Child Abuse Content, Illegal Downloads, Terrorism and Violent Extremism
Content Filtering	Category blocking	Threat categories	Malware Sites, Spyware and Adware, Phishing, Botnets, Spam, Exploits, High Risk Sites and Locations, Bogon, Ebanking Fraud, Indicators of Compromise (IOC), Domain Generated Algorithm, Open HTTP Proxy, Open Mail Relay, TOR exit Nodes, Newly Seen Domains, Cryptojacking, Linkshare, Malicious Sites
Content Filtering	URL filtering	Blocked URL list	www.example.com

Switch settings

On the dashboard under **Switching > Monitor**

Main menu	Section	Subsection	Values
Switches (select one switch)	Summary	Switch name (top left, edit mac address)	B2-SW1
		Address	<location>
Switches (select other switch)	Summary	Switch name (top left, edit mac address)	B2-SW2
		Address	<location>
Switch Stacks (select stack)	--	Stack name (top left, edit)	B2-SW-STACK1
Switch Ports (select all ports on switches which support less than 999 VLANs) (not needed in this)	Switch Ports	All ports on switch	Type: Trunk Allowed VLANs: 1,10,20,30,40,50,999

Main menu	Section	Subsection	Values
example)			

On the dashboard under **Switching > Configure**

Main menu	Section	Subsection	Values
Switch Settings	Switch settings	STP configuration	Enable Rapid Spanning Tree (RSTP): Enabled STP bridge priority: Switches/Stacks (B2-SW-STACK1) STP bridge priority: Bridge priority (4096)
Switch Settings	Switch settings	Quality of service	VLAN: 50, Trust: Disabled, Set DSCP: 0 (default) VLAN 10, Trust: Enabled VLAN 20, Trust: Enabled VLAN 30, Trust: Enabled VLAN 40, Trust: Enabled
Switch Settings	Switch settings	Storm control	<ul style="list-style-type: none"> Broadcast, 20% Multicast, 30% Unknown Unicast, 10%
Access Policies	Access Policies	Name Authentication method RADIUS servers RADIUS servers RADIUS servers RADIUS server Connection Options	Radius-MAB Radius server RADIUS Server testing RADIUS CoA support enabled Enable RADIUS accounting servers Host 10.102.1.157, secret <secret>, Auth enabled, Port 1812, Accounting enabled, Port 1813 Hybrid authentication, Multi-Auth, Both Voice auth enabled

On the dashboard under **Switching > Monitor**

Main menu	Section	Subsection	Values
Switch Ports	Switch Ports	B2-SW1/1 B2-SW1/2 B2-SW2/1 B2-SW2/2	<ul style="list-style-type: none"> Name: Uplink to Router Port status: Enabled Type: Trunk Access Policy: Open Native VLAN: 1 Allowed VLANs: 1,10,20,30,40,50,999 Peer SGT capable: Enabled Adaptive Policy group: 2: Infrastructure RSTP: Enabled STP guard: Disabled UDLD: Alert only PoE: Enabled

Main menu	Section	Subsection	Values
			<ul style="list-style-type: none"> Storm control: Enabled
Switch Ports	Switch Ports	B2-SW1/3 B2-SW1/4 B2-SW1/5	<ul style="list-style-type: none"> Name: INET1 Port status: Enabled Type: Access Access Policy: Open VLAN: 901 RSTP: Enabled STP guard: Disabled UDLD: Alert only PoE: Enabled Storm control: Enabled
Switch Ports	Switch Ports	B2-SW2/3 B2-SW2/4 B2-SW2/5	<ul style="list-style-type: none"> INET2 Port status: Enabled Type: Access Access Policy: Open VLAN: 902 RSTP: Enabled STP guard: Disabled UDLD: Alert only PoE: Enabled Storm control: Enabled
Switch Ports	Switch Ports	B2-SW1/9	<ul style="list-style-type: none"> Name: Link to AP Port status: Enabled Type: Trunk Access Policy: Open Native VLAN: 999 Allowed VLANs: 1,10,20,30,40,50,999 Peer SGT capable: Enabled Adaptive policy group: 2: Infrastructure RSTP: Enabled STP guard: BPDU guard UDLD: Alert only PoE: Enabled Storm control: Enabled
Switch Ports	Switch Ports	B2-SW1/6-8 B2-SW1/10-12 B2-SW2/6-12	<ul style="list-style-type: none"> Name: Disabled Port status: Disabled
Switch Ports	Switch Ports	B2-SW1/13-28 B2-SW2/13-28	<ul style="list-style-type: none"> Name: Access Port Port status: Enabled Type: Access Access Policy: RADIUS-MAB VLAN: 10 VOICE VLAN: 20

Main menu	Section	Subsection	Values
			<ul style="list-style-type: none"> • RSTP: Enabled • STP guard: BPDU guard • UDLD: Alert only • PoE: Enabled • Storm control: Enabled

On the dashboard under **Switching > Configure**

Main menu	Section	Subsection	Values
Switch Settings	Switch settings	VLAN configuration	999

Access Point settings

On the dashboard under **Wireless > Monitor**

Main menu	Section	Subsection	Values
Access Points (select Access Point)	Summary	Access Point name (top left, edit mac address)	B2-AP1
		Address	<Location>

On the dashboard under **Wireless > Configure**

Main menu	Section	Subsection	Values
Access Control	Basic info	SSID (name) (Unconfigured SSID 1)	BR2-GuestWiFi
Access Control	Security (Guest)		Open (no encryption)
Access Control	Security (Guest)	Mandatory DHCP	Enabled
Access Control	Splash page (Guest)		Click-through
Access Control	Client IP and VLAN (Guest)	External DHCP server assigned	Selected/Bridged
Access Control	Client IP and VLAN (Guest)	VLAN tagging	VLAN ID: Default AP tag, VLAN ID 50
Access Control>Splash page settings	Splash page (Guest)	Official themes	Modern
Access Control>Splash page settings	Customize your page (Guest)	Welcome message	Click to continue if you agree to the terms of usage of this guest service.
Access Control>Splash page settings	Splash behavior (Guest)	Splash frequency	Every day
		Where should users go after the splash page?	The URL they were trying to fetch

Main menu	Section	Subsection	Values
Access Control	Basic info	SSID (name) (Unconfigured SSID 5)	BR2-CorpWiFi
Access Control	Security (Corp)		Enterprise with my RADIUS server
Access Control	Security (Corp)	WPA encryption	WPA3 Transition Mode
Access Control	Security (Corp)	802.11w	Enabled (allow unsupported clients)
Access Control	Security (Corp)	Mandatory DHCP	Enabled
Access Control	Splash Page (Corp)		None (direct access)
Access Control	RADIUS (Corp)	RADIUS servers	10.102.1.157, 1812, <secret>
Access Control	RADIUS (Corp)	RADIUS accounting servers	10.102.1.157, 1813, <secret>
Access Control	RADIUS (Corp)	RADIUS CoA support	Disabled
Access Control	RADIUS (Corp)	RADIUS attribute specifying group policy name	Filter-Id
Access Control	Client IP and VLAN (Corp)	External DHCP server assigned	Selected/Bridged
		RADIUS override	Override VLAN tag
Access Control	Client IP and VLAN (Corp)	VLAN tagging	VLAN ID: Default AP tag, VLAN ID 10
Access Control	Security (Corp)	802.11r	Enabled
Firewall & traffic shaping	Block IPs and ports (Guest)	Layer 2 LAN isolation	Enabled
Firewall & traffic shaping	Block IPs and ports (Guest)	Outbound rules	<ul style="list-style-type: none"> Deny IPv4 Any Local LAN Any Wireless clients access LAN Allow IPV4 Any Any Any Default rule
Firewall & traffic shaping	Traffic shaping rules (Guest)	Per-client bandwidth limit	50 Mbps
		Enable SpeedBurst	Enabled
		Per-SSID bandwidth limit	100 Mbps
		Shape traffic	Shape traffic on this SSID
		Default Rules	Enable default traffic shaping rules
Firewall & traffic shaping	Block IPs and ports (Corp)	Outbound rules	<ul style="list-style-type: none"> Allow IPv4 Any Local LAN Any Wireless clients access LAN Allow IPV4 Any Any Any Default rule
Firewall & traffic shaping	Traffic shaping rules (Corp)	Per-client bandwidth limit	Unlimited
		Per-SSID bandwidth limit	Unlimited
		Shape traffic	Shape traffic on this SSID

Main menu	Section	Subsection	Values
		Default Rules	Enable default traffic shaping rules
SSID Availability	SSID availability (all SSIDs)	Visibility	Advertise this SSID publicly
		Per access point availability	Enabled on all access points
		Scheduled availability	Enabled
		Schedule templates	Custom schedule (Sun/Sat unavailable, M-F available 7:00-19:00)
Radio Settings	RRM	AI-RRM	Enable
Radio Settings	RF profiles	Basic Indoor Profile/Copy	Medium Branch Profile
Radio Settings	RF profiles (Small Branch Profile)	General/Band selection	Per SSID
Radio Settings	RF profiles (Small Branch Profile)	BR2-GuestWiFi	2.4/5
		BR2-CorpWiFi	2.4/5/6/Band steering Enabled
Radio Settings	Overview	B2-AP1/Assign profile	Medium Branch Profile

On the dashboard under **Security & SD-WAN > Configure**

Note: For some MS switch stack models (such as the MS150, but not the MS390), there may be an issue moving all switch members into VLAN 999. If this is the case, configure Native VLAN 999 on the MX trunk port as a workaround. If this workaround is implemented, the switch trunks to the APs must be moved back to VLAN 1.

Main menu	Section	Subsection	Values
Addressing & VLANs	Routing	Per-port VLAN settings	Port 5: Native VLAN 999
Switch Ports	Switch Ports	B2-SW1/9	Native VLAN: 1

Appendix C: ISE Deployment Settings

This table documents the ISE deployment settings for the example deployment:

Main menu	Section	Subsection	Values
Administration	Groups	Endpoint Identity Groups	<ul style="list-style-type: none"> • MAB-IOT_Devices • MAB-VOICE_Devices • MAB-PCI_Devices
Administration	Groups	User Identity Groups	<ul style="list-style-type: none"> • Employee • Finance • Marketing • IOT • Voice • PCI
Policy	Policy Elements/Results	Authorization Profiles/DATA_VLAN	<ul style="list-style-type: none"> • Access Type = ACCESS_ACCEPT • Tunnel-Private-Group-ID = 1:10 • Tunnel-Type = 1:13 • Tunnel-Medium-Type = 1:6
Policy	Policy Elements/Results	Authorization Profiles/DATA-GP	<ul style="list-style-type: none"> • Access Type = ACCESS_ACCEPT • Filter-ID = DATA
Policy	Policy Elements/Results	Authorization Profiles/Voice_VLAN	<ul style="list-style-type: none"> • Access Type = ACCESS_ACCEPT • Tunnel-Private-Group-ID = 1:20 • Tunnel-Type = 1:13 • Tunnel-Medium-Type = 1:6 • cisco-av-pair = device-traffic-class=voice
Policy	Policy Elements/Results	Authorization Profiles/Voice-GP	<ul style="list-style-type: none"> • Access Type = ACCESS_ACCEPT • Filter-ID = VOICE
Policy	Policy Elements/Results	Authorization Profiles/IOT_VLAN	<ul style="list-style-type: none"> • Access Type = ACCESS_ACCEPT • Tunnel-Private-Group-ID = 1:30 • Tunnel-Type = 1:13 • Tunnel-Medium-Type = 1:6
Policy	Policy Elements/Results	Authorization Profiles/IOT-GP	<ul style="list-style-type: none"> • Access Type = ACCESS_ACCEPT • Filter-ID = IOT
Policy	Policy Elements/Results	Authorization Profiles/PCI_VLAN	<ul style="list-style-type: none"> • Access Type = ACCESS_ACCEPT • Tunnel-Private-Group-ID = 1:40 • Tunnel-Type = 1:13 • Tunnel-Medium-Type = 1:6
Policy	Policy Elements/Results	Authorization Profiles/PCI-GP	<ul style="list-style-type: none"> • Access Type = ACCESS_ACCEPT • Filter-ID = PCI
Policy	Policy Elements/Results	Authorization Profiles/Finance_SGT	<ul style="list-style-type: none"> • Access Type = ACCESS_ACCEPT • cisco-av-pair = cts:security-group-tag=000A-0
Policy	Policy	Authorization	<ul style="list-style-type: none"> • Access Type = ACCESS_ACCEPT

Main menu	Section	Subsection	Values
	Elements/Results	Profiles/Marketing_SGT	<ul style="list-style-type: none"> cisco-av-pair = cts:security-group-tag=0014-0
Policy	Policy Sets (Wired Access)	Conditions: Wired_802.1X or Wired_MAB	<ul style="list-style-type: none"> Authentication Policy: <ul style="list-style-type: none"> Wired_MAB (Internal Endpoints) Default (All_User_ID_Stores) Authorization Policy: <ul style="list-style-type: none"> IdentityGroup:Name = Endpoint Identity Groups:MAB-IOT_Devices or IdentityGroup:Name = User Identity Groups:IOT, Profile=IOT_VLAN IdentityGroup:Name = Endpoint Identity Groups:MAB-PCI_Devices or IdentityGroup:Name = User Identity Groups:PCI, Profile=PCI_VLAN IdentityGroup:Name = Endpoint Identity Groups:MAB-VOICE_Devices or IdentityGroup:Name = User Identity Groups:Voice, Profile=Voice_VLAN IdentityGroup:Name = Finance, Profile=DATA_VLAN, Finance_SGT IdentityGroup:Name = Marketing, Profile=DATA_VLAN, Marketing_SGT IdentityGroup:Name = Employee, Profile=DATA_VLAN
Policy	Policy Sets (Wireless Access)	Conditions: Wireless_802.1X	<ul style="list-style-type: none"> Authentication Policy: <ul style="list-style-type: none"> Default (All_User_ID_Stores) Authorization Policy: <ul style="list-style-type: none"> IdentityGroup:Name = User Identity Groups:IOT, Profile=IOT-GP IdentityGroup:Name = User Identity Groups:PCI, Profile=PCI-GP IdentityGroup:Name = User Identity Groups:Voice, Profile=Voice-GP IdentityGroup:Name = User Identity Groups:Finance, Profile=DATA-GP, Finance_SGT IdentityGroup:Name = User Identity Groups:Marketing, Profile=DATA-GP, Marketing_SGT IdentityGroup:Name = User Identity Groups:Employee, Profile=DATA-GP

Appendix D: References

- [Unified Branch Solution Brief](#)
- [Unified Branch Design Guide](#) (CVD)
- [Unified Branch Small Branch Deployment Guide](#) (CVD)
- [Unified Branch Large Branch Deployment Guide](#) (CVD)
- [Unified Branch Workflows Automation Toolkit](#)
- [Cisco Network as Code Website](#)
- [Branch as Code Github Repository](#)
- [From Fragmented to Future-ready with Unified Branch: Powering IT in the AI Era](#)
- [Cisco Unified Branch Product Page](#)
- [Meraki Documentation](#)