



# **Cisco Secure Web Appliance S196, S396, S696, and S696F Hardware Installation Guide**

**First Published:** 2024-04-11

## **Americas Headquarters**

Cisco Systems, Inc.  
170 West Tasman Drive  
San Jose, CA 95134-1706  
USA  
<http://www.cisco.com>  
Tel: 408 526-4000  
800 553-NETS (6387)  
Fax: 408 527-0883

THE SPECIFICATIONS AND INFORMATION REGARDING THE PRODUCTS IN THIS MANUAL ARE SUBJECT TO CHANGE WITHOUT NOTICE. ALL STATEMENTS, INFORMATION, AND RECOMMENDATIONS IN THIS MANUAL ARE BELIEVED TO BE ACCURATE BUT ARE PRESENTED WITHOUT WARRANTY OF ANY KIND, EXPRESS OR IMPLIED. USERS MUST TAKE FULL RESPONSIBILITY FOR THEIR APPLICATION OF ANY PRODUCTS.

THE SOFTWARE LICENSE AND LIMITED WARRANTY FOR THE ACCOMPANYING PRODUCT ARE SET FORTH IN THE INFORMATION PACKET THAT SHIPPED WITH THE PRODUCT AND ARE INCORPORATED HEREIN BY THIS REFERENCE. IF YOU ARE UNABLE TO LOCATE THE SOFTWARE LICENSE OR LIMITED WARRANTY, CONTACT YOUR CISCO REPRESENTATIVE FOR A COPY.

The Cisco implementation of TCP header compression is an adaptation of a program developed by the University of California, Berkeley (UCB) as part of UCB's public domain version of the UNIX operating system. All rights reserved. Copyright © 1981, Regents of the University of California.

NOTWITHSTANDING ANY OTHER WARRANTY HEREIN, ALL DOCUMENT FILES AND SOFTWARE OF THESE SUPPLIERS ARE PROVIDED "AS IS" WITH ALL FAULTS. CISCO AND THE ABOVE-NAMED SUPPLIERS DISCLAIM ALL WARRANTIES, EXPRESSED OR IMPLIED, INCLUDING, WITHOUT LIMITATION, THOSE OF MERCHANTABILITY, FITNESS FOR A PARTICULAR PURPOSE AND NON-INFRINGEMENT OR ARISING FROM A COURSE OF DEALING, USAGE, OR TRADE PRACTICE.

IN NO EVENT SHALL CISCO OR ITS SUPPLIERS BE LIABLE FOR ANY INDIRECT, SPECIAL, CONSEQUENTIAL, OR INCIDENTAL DAMAGES, INCLUDING, WITHOUT LIMITATION, LOST PROFITS OR LOSS OR DAMAGE TO DATA ARISING OUT OF THE USE OR INABILITY TO USE THIS MANUAL, EVEN IF CISCO OR ITS SUPPLIERS HAVE BEEN ADVISED OF THE POSSIBILITY OF SUCH DAMAGES.

Any Internet Protocol (IP) addresses and phone numbers used in this document are not intended to be actual addresses and phone numbers. Any examples, command display output, network topology diagrams, and other figures included in the document are shown for illustrative purposes only. Any use of actual IP addresses or phone numbers in illustrative content is unintentional and coincidental.

All printed copies and duplicate soft copies of this document are considered uncontrolled. See the current online version for the latest version.

Cisco has more than 200 offices worldwide. Addresses and phone numbers are listed on the Cisco website at [www.cisco.com/go/offices](http://www.cisco.com/go/offices).

Cisco and the Cisco logo are trademarks or registered trademarks of Cisco and/or its affiliates in the U.S. and other countries. To view a list of Cisco trademarks, go to this URL: <https://www.cisco.com/c/en/us/about/legal/trademarks.html>. Third-party trademarks mentioned are the property of their respective owners. The use of the word partner does not imply a partnership relationship between Cisco and any other company. (1721R)

© 2024 Cisco Systems, Inc. All rights reserved.



## CONTENTS

---

### CHAPTER 1

#### **Overview 1**

- Features 1
- Package Contents 4
- Serial Number Locations 5
- Front Panel 6
- Front Panel LEDs 9
- Rear Panel 12
- Rear Panel LEDs 15
- Power Supply 17
- Hardware Specifications 17
- Product ID (PID) Numbers 18
- Power Cord Specifications 19

---

### CHAPTER 2

#### **Installation Preparation 27**

- Installation Warnings 27
- Safety Recommendations 29
- Maintain Safety with Electricity 30
- Prevent ESD Damage 30
- Site Environment 31
- Site Considerations 31
- Power Supply Considerations 31
- Rack Configuration Considerations 32

---

### CHAPTER 3

#### **Rack-Mount the Chassis 33**

- Unpack and Inspect the Chassis 33
- Rack-Mount the Chassis 34

---

**CHAPTER 4**

**Maintenance and Upgrades 37**

Power Button Shut Down 37

Enable RPC 38

Reset the Chassis Remotely 39

Install/Uninstall the Locking Faceplate 39

Remove and Replace a Drive 40

Remove and Replace a Power Supply 43



# CHAPTER 1

## Overview

---

- [Features, on page 1](#)
- [Package Contents, on page 4](#)
- [Serial Number Locations, on page 5](#)
- [Front Panel, on page 6](#)
- [Front Panel LEDs , on page 9](#)
- [Rear Panel, on page 12](#)
- [Rear Panel LEDs, on page 15](#)
- [Power Supply, on page 17](#)
- [Hardware Specifications, on page 17](#)
- [Product ID \(PID\) Numbers, on page 18](#)
- [Power Cord Specifications, on page 19](#)

## Features

The Cisco Secure Web Appliance includes the S196, S396, S696, and S696F. It helps organizations secure and control web traffic.

The Secure Web Appliance S196, S396, S696, and S696F support Cisco AsyncOS version 15.2 and later. See [Product ID \(PID\) Numbers, on page 18](#) for a list of field-replaceable product IDs (PIDs) associated with the Secure Web Appliance.

The following figures show the Cisco Secure Web Appliance series.

*Figure 1: Cisco Secure Web Appliance S196 and S396*



*Figure 2: Cisco Secure Web Appliance S696 and S696F*



The following table lists the features of the Secure Web Appliance S196, S396, S696, and S696F.

**Table 1: Secure Web Appliance S196, S396, S696, and S696F Features**

Feature	S196	S396	S696	S696F
Form factor	1 RU		2 RU	
Rack mount	Standard 19-inch (48.3 cm) 4-post EIA rack			
Airflow	Front to rear Cold aisle to hot aisle			
Pullout asset card	Displays the serial number			

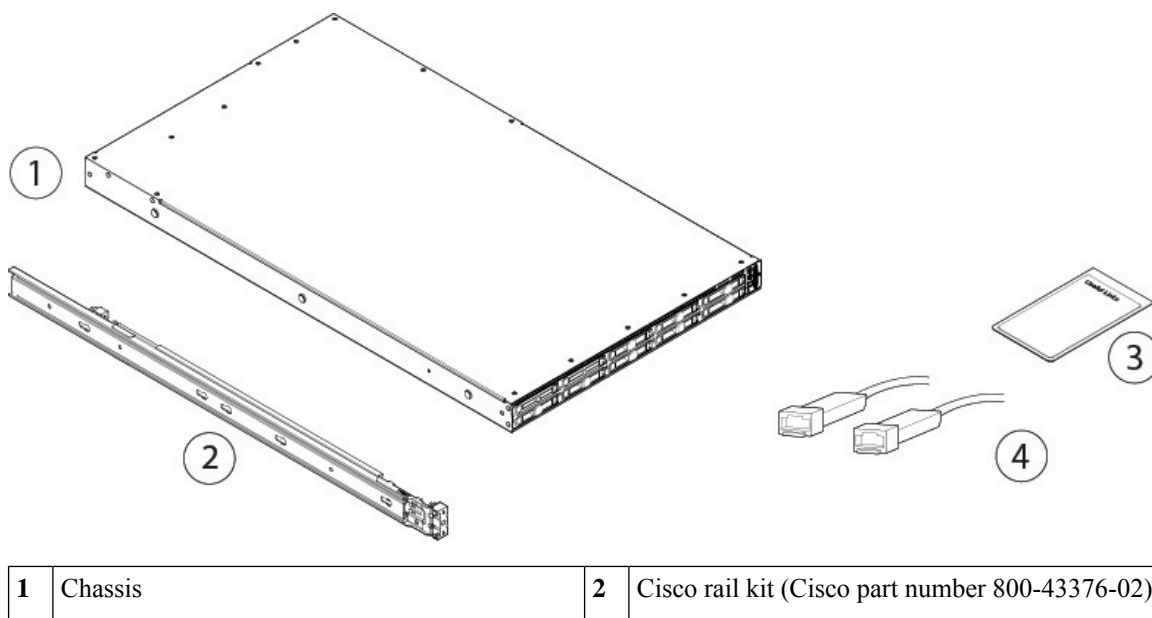
Feature	S196	S396	S696	S696F
Grounding holes	Two threaded holes for dual-hole grounding lug Use is optional; the supported AC power supplies have internal grounding, so no additional chassis grounding is required.			
Locking faceplate	Optional			
Unit identification button	On front panel			
Power button	On front panel			
Memory	16-GB RAM	64-GB RAM	128-GB RAM	
RDIMMs Internal component only; not field-replaceable	One 16-GB SRx4 3200-MHz DIMM (8 Gb)	Two 32-GB SRx4 3200-MHz DIMM (16 Gb)	Four 32-GB DRx4 3200-MHz DIMM (8 Gb)	
Management ports	One (M1) M2 is not supported.			
Proxy ports	Two (P1 and P2)			
Traffic ports	Two (T1 and T2)			
Remote power cycling (RPC)	Accessed through the 1-Gb dedicated port			
USB ports	Two USB 3.0 Type A			
SFP+ ports	No			Six fiber optic
Supported SFP+ <b>Note</b> Copper SFPs are not supported.	—			SFP-10G-SR (10 Gb) <b>Note</b> SFP-10G-SR has been qualified by Cisco. Use only Cisco-qualified SFPs. We recommend you use SFP-10G-SR in the secure web appliance interface and the corresponding switch interface.

Feature	S196	S396	S696	S696F
Serial console port	One 1-Gb RJ45 serial port running RS-232 (RS-232D TIA-561)			
AC power supply <b>Note</b> Do not mix power supply type or wattage between models.	Two 1050 W AC Hot-swappable and redundant as 1+1			
Fans	Six fans for front-to-rear cooling Internal component only; not field-replaceable. If one fan fails, you must send your chassis for return material authorization (RMA).			
Storage	Two 1.2-TB SAS HDDs RAID 1, hot-swappable	Four 1.2-TB SAS HDDs RAID 10, hot-swappable	Ten 1.2-TB SAS HDDs RAID 10, hot-swappable	

## Package Contents

The following figure shows the package contents for the Secure Web Appliance S196, S396, S696, and S696F. Note that the contents are subject to change and your exact contents might contain additional or fewer items.

**Figure 3: Secure Web Appliance Package Contents**



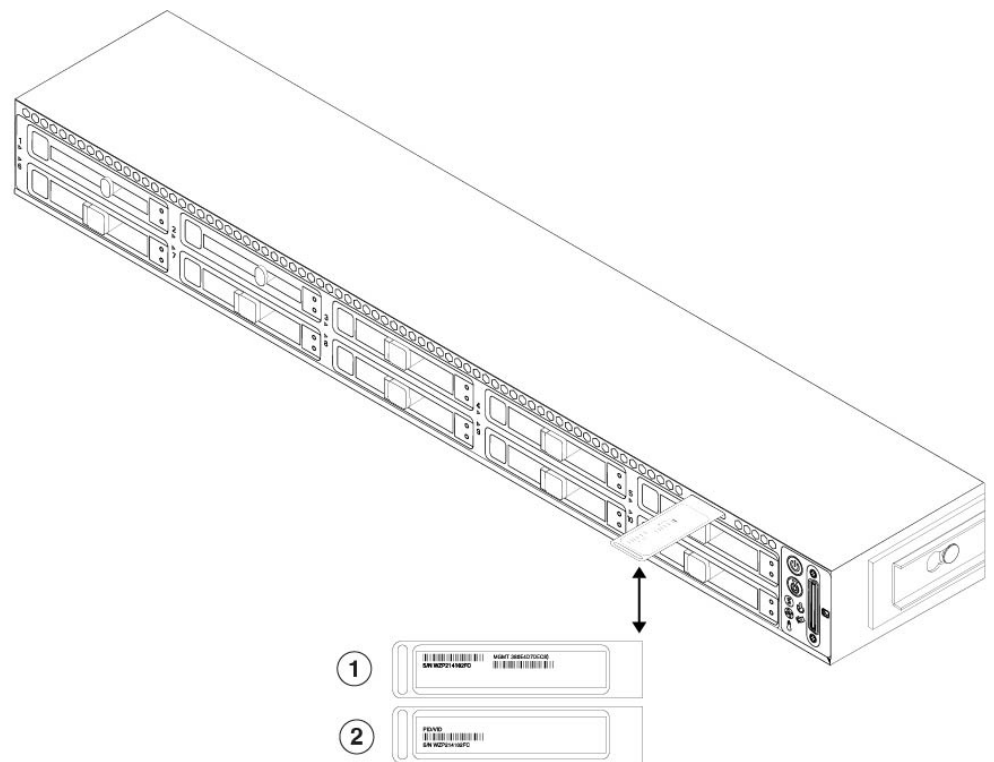


<p><b>3</b></p>	<p><i>Cisco Secure Web Appliance S196, S396, S696, S696F</i></p> <p>This document contains URLs that point to the hardware installation guide, regulatory compliance and safety information guide, the getting started guide, and a QR code that points to the secure web appliance Documentation Portal.</p>	<p><b>4</b></p>	<p>Two 10-Gb SFP+ fiber optic transceivers with cables</p> <p><b>Note</b> Supported on the S696F. You cannot mix SFP transceiver types in the same chassis. 1-Gb SFPs are not supported on the S696F.</p>
-----------------	---	-----------------	---

## Serial Number Locations

The Serial Number (SN) and the Media Access Control (MAC) address for the Secure Web Appliance S196, S396, S696, and S696F are printed on the top of the pullout asset card located on the front panel as shown in the following figure of the Secure Web Appliance S196. The PID (Product ID) and VID (Version ID) are printed on the back of the pullout asset card.

**Figure 4: Serial Number on Pullout Asset Card**



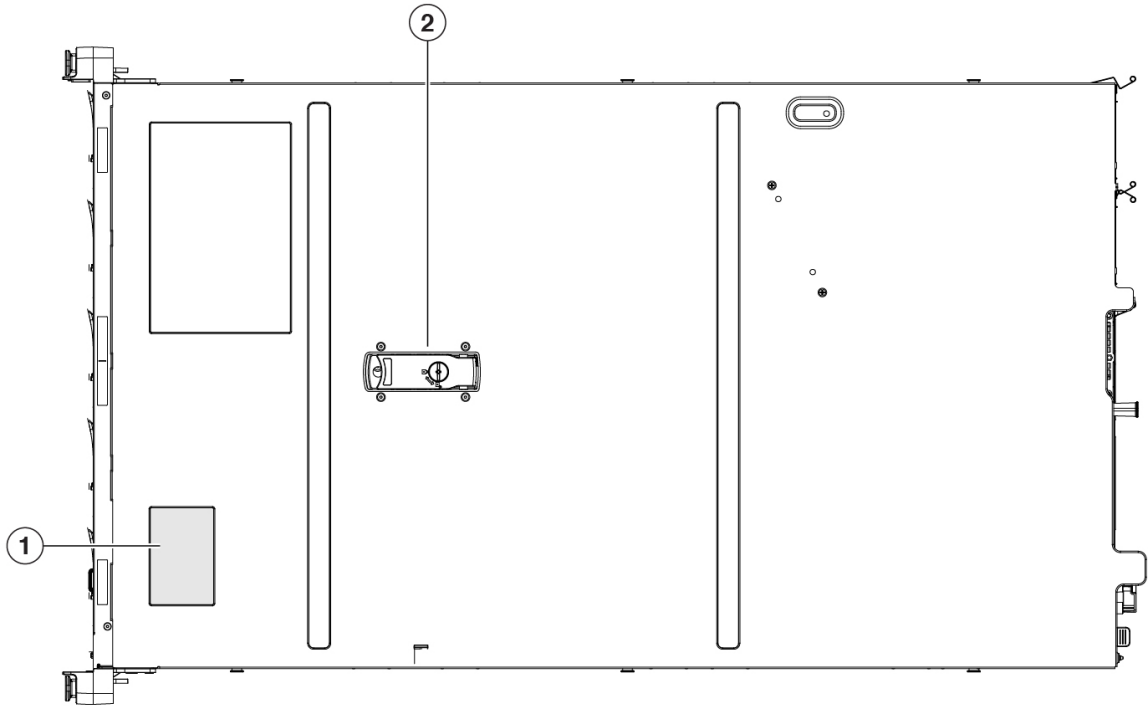
<p><b>1</b></p>	<p>Front of the pullout asset tag with the SN and MAC address</p>	<p><b>2</b></p>	<p>Bottom of the pullout asset tag with the PID and VID numbers</p>
-----------------	---	-----------------	---

The serial number is also on the label on the cover of the chassis as shown in the following figure.



**Caution** The cover latch on the top of the chassis cover is not supported. There are no internal field-replaceable parts in the Secure Web Appliance S196, S396, S696, and S696F.

**Figure 5: Serial Number Location on Cover**

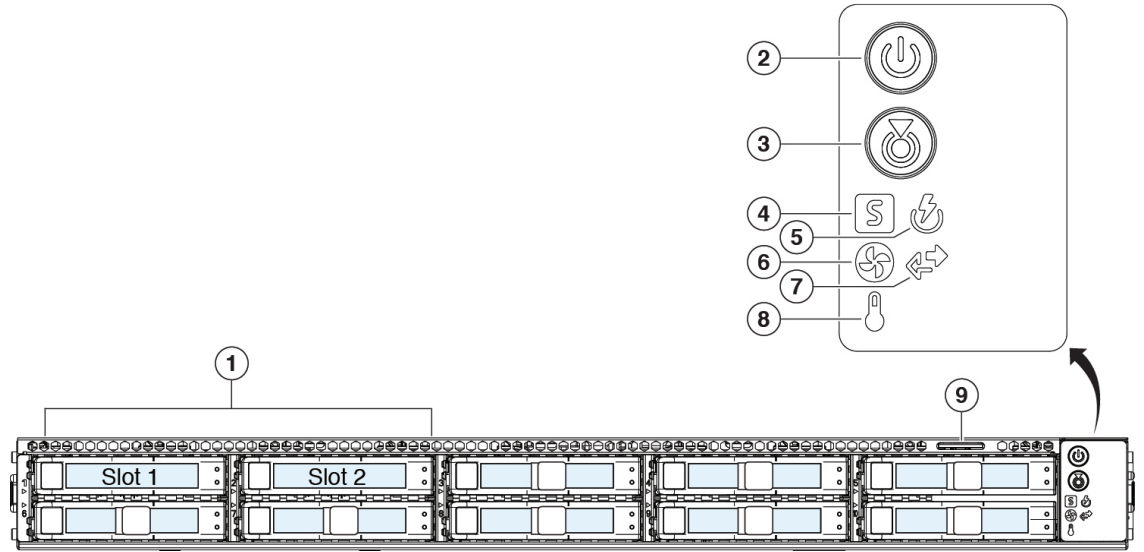


<p><b>1</b> Chassis compliance labels with the SN, MAC address, etc. and a QR code that points to the Documentation Portal</p> <p><b>Note</b> Scan the QR code to go to the Documentation Portal, which has links to the product page, hardware installation guide, the regulatory and compliance guide, and the getting started guide.</p>	<p><b>2</b> Cover latch Not supported</p>
---	---

## Front Panel

The following figure shows the front panel features and disk-drive configuration for the Secure Web Appliance S196. See [Front Panel LEDs](#), on page 9 for a description of the LEDs.

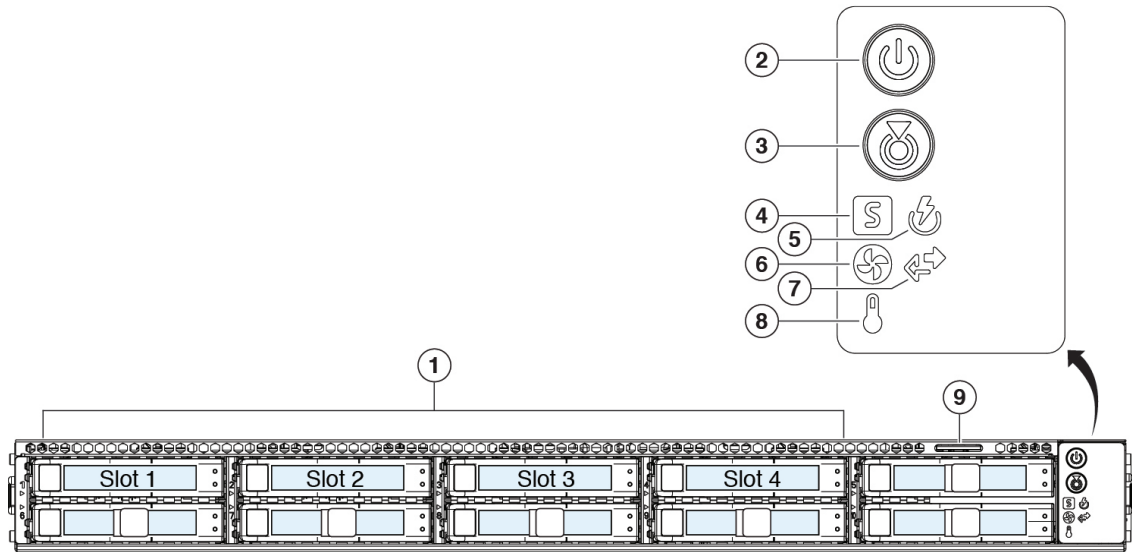
Figure 6: Secure Web Appliance S196 Front Panel



<b>1</b>	Drive bays Supports two 1.2-TB SAS HDDs in slots 1 and 2	<b>2</b>	Power button/power status LED
<b>3</b>	Unit identification button/LED	<b>4</b>	System status LED
<b>5</b>	Power supply status LED	<b>6</b>	Fan status LED
<b>7</b>	Network link activity LED	<b>8</b>	Temperature status LED
<b>9</b>	Pullout asset card	—	

The following figure shows the front panel features and disk-drive configuration for the Secure Web Appliance S396. See [Front Panel LEDs](#) , on page 9 for a description of the LEDs.

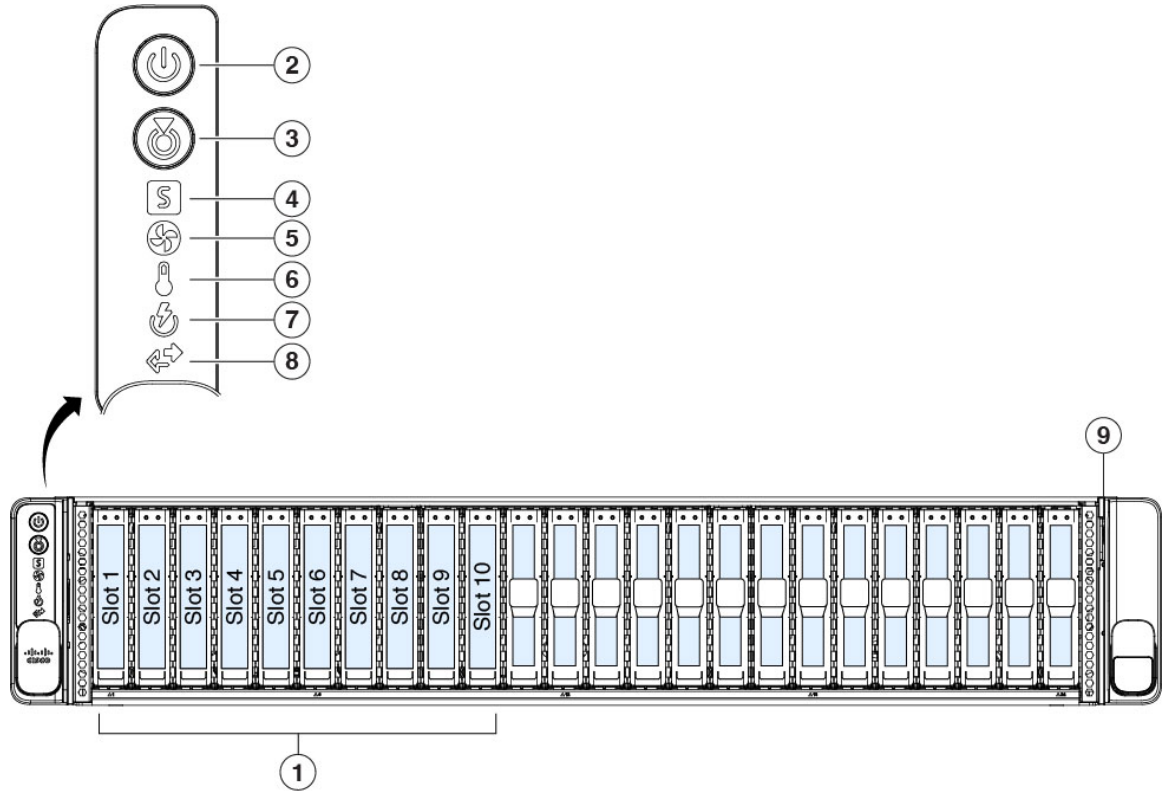
Figure 7: Secure Web Appliance S396 Front Panel



<b>1</b> Drive bays Supports four 1.2-TB SAS HDDs in slots 1 through 4	<b>2</b> Power button/power status LED
<b>3</b> Unit identification button/LED	<b>4</b> System status LED
<b>5</b> Power supply status LED	<b>6</b> Fan status LED
<b>7</b> Network link activity LED	<b>8</b> Temperature status LED
<b>9</b> Pullout asset card	—

The following figure shows the front panel features and disk-drive configuration for the Secure Web Appliance S695 and S695F. See [Front Panel LEDs](#), on page 9 for a description of the LEDs.

Figure 8: Secure Web Appliance S696 and S696F Front Panel

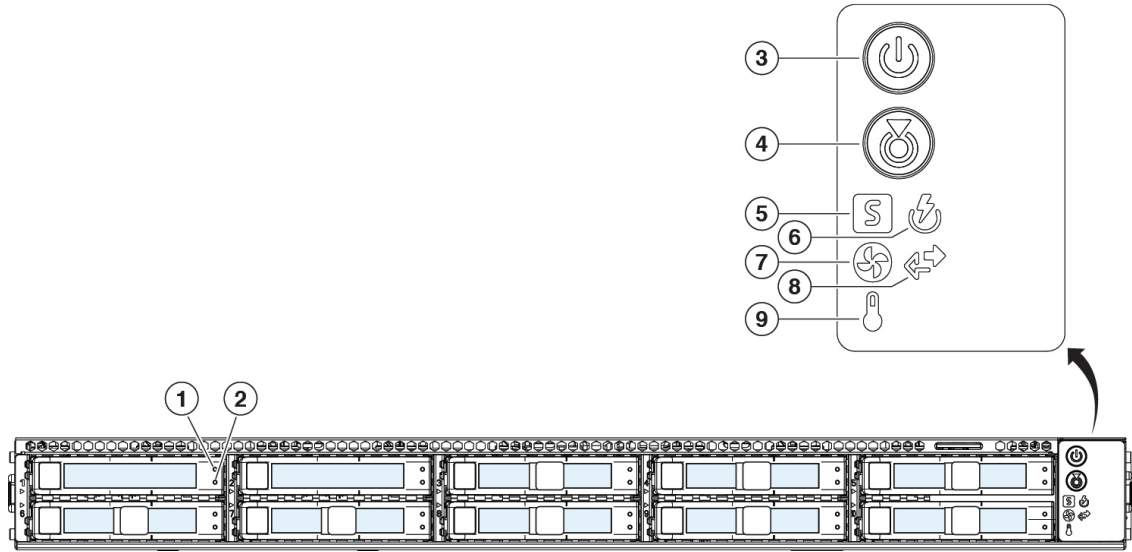


<b>1</b> Drive bays Supports ten 1.2-TB SAS HDDs in slots 1 through 10	<b>2</b> Power button/power status LED
<b>3</b> Unit identification button/LED	<b>4</b> System status LED
<b>5</b> Fan status LED	<b>6</b> Temperature status LED
<b>7</b> Power supply status LED	<b>8</b> Network link activity LED
<b>9</b> Pullout asset card	—

## Front Panel LEDs

The following figure shows the front panel LEDs for the Secure Web Appliance S196, S396, S696, and S696F, and describes their states.

Figure 9: Front Panel LEDs



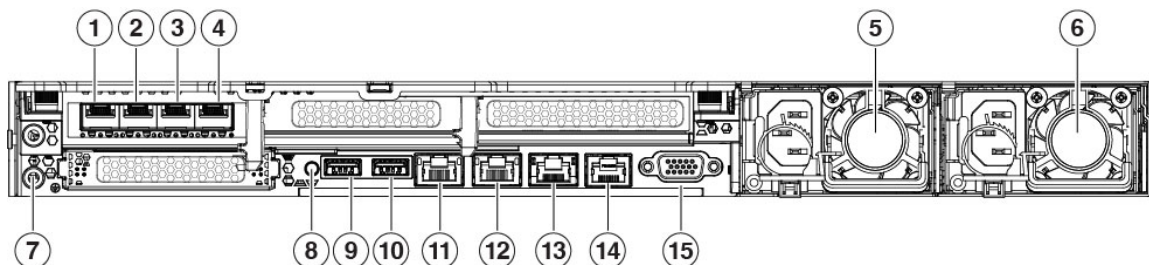
<p><b>1</b> Drive fault LED:</p> <ul style="list-style-type: none"> <li>• Off—The drive is operating properly.</li> <li>• Amber—Drive fault detected.</li> <li>• Amber, flashing—The drive is rebuilding.</li> <li>• Amber, flashing with 1-second interval—Drive locate function activated in the software.</li> </ul>	<p><b>2</b> Drive activity LED:</p> <ul style="list-style-type: none"> <li>• Off—There is no drive in the drive tray (no access, no fault).</li> <li>• Green—The drive is ready.</li> <li>• Green, flashing—The drive is reading or writing data.</li> </ul>
<p><b>3</b> Power LED:</p> <ul style="list-style-type: none"> <li>• Off—There is no AC power to the chassis.</li> <li>• Amber—The chassis is in standby mode.</li> <li>• Green—The chassis is in main power mode. Power is supplied to all components.</li> </ul>	<p><b>4</b> Unit identification LED:</p> <ul style="list-style-type: none"> <li>• Off—The unit identification function is not in use.</li> <li>• Blue, flashing—The unit identification function is activated.</li> </ul>

5	<p>System status LED:</p> <ul style="list-style-type: none"> <li>• Green—The chassis is running in normal operating condition.</li> <li>• Green, flashing—The chassis is performing system initialization and memory check.</li> <li>• Amber—The chassis is in a degraded operational state (minor fault). <ul style="list-style-type: none"> <li>• Power supply redundancy is lost.</li> <li>• CPUs are mismatched.</li> <li>• At least one CPU is faulty.</li> <li>• At least one DIMM is faulty.</li> <li>• At least one drive in a RAID configuration failed.</li> </ul> </li> <li>• Amber, 2 flashes—There is a major fault with the system board.</li> <li>• Amber, 3 flashes—There is a major fault with the DIMMs.</li> <li>• Amber, 4 flashes—There is a major fault with the CPUs.</li> </ul>	6	<p>Power supply status LED:</p> <ul style="list-style-type: none"> <li>• Green—All power supplies are operating normally.</li> <li>• Amber—One or more power supplies are in a degraded operational state.</li> <li>• Amber, flashing—One or more power supplies are in a critical fault state.</li> </ul>
7	<p>Fan status LED:</p> <ul style="list-style-type: none"> <li>• Green—All fans are operating properly.</li> <li>• Amber, flashing—One or more fans breached the nonrecoverable threshold.</li> </ul>	8	<p>Network link activity LED:</p> <ul style="list-style-type: none"> <li>• Off—The Ethernet port link is idle.</li> <li>• Green—One or more Ethernet ports are link-active, but there is no activity.</li> <li>• Green, flashing—One or more Ethernet ports are link-active with activity.</li> </ul>
9	<p>Temperature status LED:</p> <ul style="list-style-type: none"> <li>• Green—The chassis is operating at normal temperature.</li> <li>• Amber—One or more temperature sensors breached the critical threshold.</li> <li>• Amber, flashing—One or more temperature sensors breached the nonrecoverable threshold.</li> </ul>	—	

## Rear Panel

The following figure shows the rear panel of the Secure Web Appliance S196 and S396. See [Rear Panel LEDs, on page 15](#) for a description of the LEDs.

**Figure 10: Secure Web Appliance S196 and S396 Rear Panel**

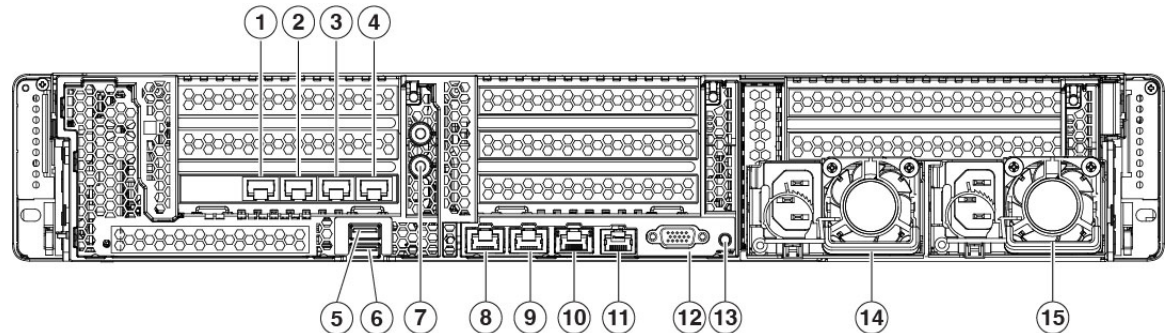


<p><b>1</b> Proxy port 1 (P1) Connects to the network for both incoming and outgoing traffic.</p>	<p><b>2</b> Proxy port 2 (P2) When P1 and P2 are both enabled, you must connect P1 to the internal network and P2 to the internet. <b>Note</b> You can connect P1 and P2 to an L4 switch, WCCP router, or network switch.</p>
<p><b>3</b> Traffic monitor port 1 (T1) Use for Duplex Ethernet tap; one cable for all incoming and outgoing traffic.</p>	<p><b>4</b> Traffic monitor port 2 (T2) Use for Simplex Ethernet tap; one cable connected to T1 for all packets going to the internet. and one cable connected to T2 for all packets coming from the internet.</p>
<p><b>5</b> 1050-W AC power supply (PSU 2)</p>	<p><b>6</b> 1050-W AC power supply (PSU 1)</p>
<p><b>7</b> Threaded holes for dual-hole grounding lug Use is optional. The supported AC power supplies have internal grounding, so no additional chassis grounding is required.</p>	<p><b>8</b> Unit identification button</p>
<p><b>9</b> USB 3.0 Type A (USB 2)</p>	<p><b>10</b> USB 3.0 Type A (USB 1)</p>
<p><b>11</b> Management interface (M1) Restricted to management use only</p>	<p><b>12</b> Management interface (M2) Not in use</p>
<p><b>13</b> RPC port (RPC) Used for remote power cycling</p>	<p><b>14</b> Serial console port (Console) RJ-45 connector that directly connects a management computer to the appliance.</p>
<p><b>15</b> VGA video port (DB-15 connector) Not supported</p>	<p>—</p>



The following figure shows the rear panel of the Secure Web Appliance S696. See [Rear Panel LEDs](#), on page 15 for a description of the LEDs.

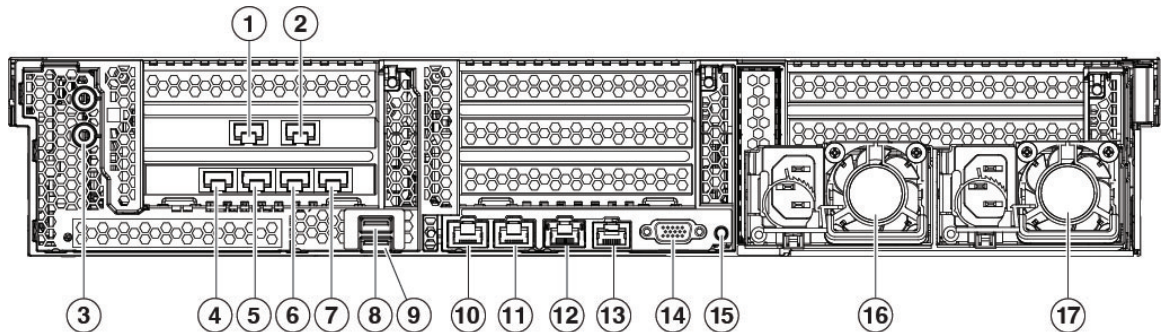
**Figure 11: Secure Web Appliance S696 Rear Panel**



<b>1</b>	Proxy port 1 (P1) Connects to the network for both incoming and outgoing traffic.	<b>2</b>	Proxy port 2 (P2) When P1 and P2 are both enabled, you must connect P1 to the internal network and P2 to the internet. <b>Note</b> You can connect P1 and P2 to an L4 switch, WCCP router, or network switch.
<b>3</b>	Traffic monitor port 1 (T1) Use for Duplex Ethernet tap; one cable for all incoming and outgoing traffic.	<b>4</b>	Traffic monitor port 2 (T2) Use for Simplex Ethernet tap; one cable connected to T1 for all packets going to the internet, and one cable connected to T2 for all packets coming from the internet.
<b>5</b>	USB 3.0 Type A (USB 1)	<b>6</b>	USB 3.0 Type A (USB 2)
<b>7</b>	Threaded holes for dual-hole grounding lug Use is optional. The supported AC power supplies have internal grounding, so no additional chassis grounding is required.	<b>8</b>	Management interface 1 (MGMT 1) Restricted to management use only
<b>9</b>	Management interface 2 (MGMT 2) Not supported	<b>10</b>	RPC port (RPC) Used for remote power cycling
<b>11</b>	Serial console port RJ-45 connector that directly connects a management computer to the appliance.	<b>12</b>	VGA video port (DB-15 connector) Not supported
<b>13</b>	Unit identification button	<b>14</b>	1050-W AC power supply (PSU 1)
<b>15</b>	1050-W AC power supply (PSU 2)		—

The following figure shows the rear panel of the Secure Web Appliance S696F. See [Rear Panel LEDs](#), on page 15 for a description of the LEDs.

Figure 12: Secure Web Appliance S696F Rear Panel



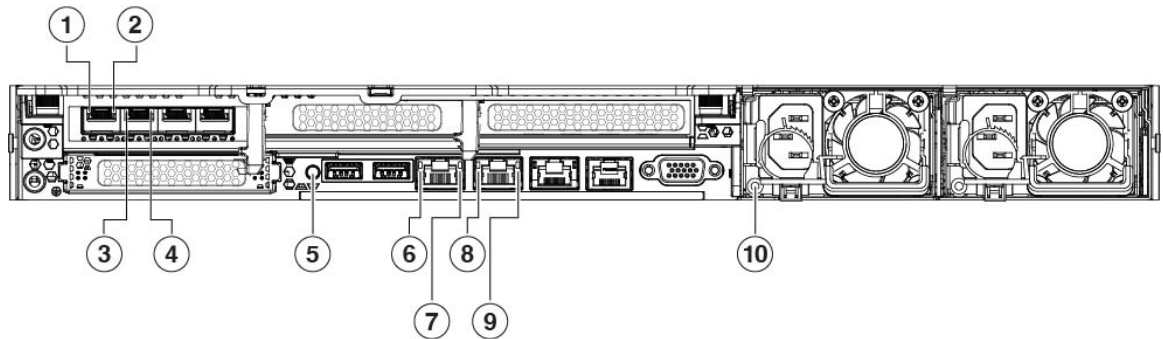
<p><b>1</b> Management interface 1 (MGMT 1) Restricted to management use only 10-Gigabit Ethernet SFP+ support</p> <p><b>Note</b> The SFP-10G-SR (10 Gb) is the only SFP+ transceiver qualified by Cisco. Use only Cisco-qualified SFPs.</p> <p><b>Note</b> Copper SFPs are not supported.</p>	<p><b>2</b> Management interface 2 (MGMT 2) Not in use</p> <p><b>Caution</b> Do not install any SFPs into this interface.</p>
<p><b>3</b> Threaded holes for dual-hole grounding lug Use is optional; the supported AC power supplies have internal grounding, so no additional chassis grounding is required.</p>	<p><b>4</b> Proxy port 1 (P1) Connects to the network for both incoming and outgoing traffic. The SFP-10G-SR (10 Gb) is the only SFP+ transceiver qualified by Cisco. Use only Cisco-qualified SFPs.</p> <p><b>Note</b> Copper SFPs are not supported.</p>
<p><b>5</b> Proxy port 2 (P2) When P1 and P2 are both enabled, you must connect P1 to the internal network and P2 to the internet.</p> <p><b>Note</b> You can connect P1 and P2 to an L4 switch, WCCP router, or network switch.</p> <p>10-Gigabit Ethernet SFP+ support The SFP-10G-SR (10 Gb) is the only SFP+ transceiver qualified by Cisco. Use only Cisco-qualified SFPs.</p> <p><b>Note</b> Copper SFPs are not supported.</p>	<p><b>6</b> Traffic monitor port 1 (T1) Use for Duplex Ethernet tap; one cable for all incoming and outgoing traffic. 10-Gigabit Ethernet SFP+ support</p> <p><b>Note</b> The SFP-10G-SR (10 Gb) is the only SFP+ transceiver qualified by Cisco. Use only Cisco-qualified SFPs.</p> <p><b>Note</b> Copper SFPs are not supported.</p>

7	<p>Traffic monitor port 2 (T2)</p> <p>Use for Simplex Ethernet tap; one cable connected to T1 for all packets going to the internet, and one cable connected to T2 for all packets coming from the internet.</p> <p>10-Gigabit Ethernet SFP+ support</p> <p><b>Note</b> The SFP-10G-SR (10 Gb) is the only SFP+ transceiver qualified by Cisco. Use only Cisco-qualified SFPs.</p> <p><b>Note</b> Copper SFPs are not supported.</p>	8	USB 3.0 Type A (USB 1)
9	USB 3.0 Type A (USB 2)	10	Data interface (DATA 1) Not supported
11	Data interface (DATA 2) Not supported	12	RPC port (RPC) Used for remote power cycling
13	Serial console port (Console) RJ-45 connector that directly connects a management computer to the appliance.	14	VGA video port (DB-15 connector) Not supported
15	Unit identification button	16	1050-W AC power supply (PSU 1)
17	1050-W AC power supply (PSU 2)		—

## Rear Panel LEDs

The following figure shows the rear panel LEDs of the Secure Web Appliance S196 and describes their states. The Secure Web Appliance S396 is the same except it has two power supplies. The Secure Web Appliance S696 and S696F have the same LEDs except that these models have more data interfaces; the speed and status LED descriptions are the same.

**Figure 13: Rear Panel LEDs**



<b>1</b> Data interface link speed: <ul style="list-style-type: none"> <li>• Off—Link speed is 100 Mbps.</li> <li>• Amber—Link speed is 1 Gbps.</li> <li>• Green—Link speed is 10 Gbps.</li> </ul>	<b>2</b> Data interface link status: <ul style="list-style-type: none"> <li>• Off—No link is present.</li> <li>• Green—Link is active.</li> <li>• Green, flashing—Traffic is present on the active link.</li> </ul>
<b>3</b> Data interface link speed: <ul style="list-style-type: none"> <li>• Off—Link speed is 100 Mbps.</li> <li>• Amber—Link speed is 1 Gbps.</li> <li>• Green—Link speed is 10 Gbps.</li> </ul>	<b>4</b> Data interface link status: <ul style="list-style-type: none"> <li>• Off—No link is present.</li> <li>• Green—Link is active.</li> <li>• Green, flashing—Traffic is present on the active link.</li> </ul>
<b>5</b> Rear unit identification: <ul style="list-style-type: none"> <li>• Off—The unit identification function is not in use.</li> <li>• Blue, flashing—The unit identification function is activated.</li> </ul>	<b>6</b> Management interface link speed: <ul style="list-style-type: none"> <li>• Off—Link speed is 100 Mbps.</li> <li>• Amber—Link speed is 1 Gbps.</li> <li>• Green—Link speed is 10 Gbps.</li> </ul>
<b>7</b> Management interface link status: <ul style="list-style-type: none"> <li>• Off—No link is present.</li> <li>• Green—Link is active.</li> <li>• Green, flashing—Traffic is present on the active link.</li> </ul>	<b>4</b> Management interface link speed: <ul style="list-style-type: none"> <li>• Off—Link speed is 100 Mbps.</li> <li>• Amber—Link speed is 1 Gbps.</li> <li>• Green—Link speed is 10 Gbps.</li> </ul>
<b>5</b> Management interface link status: <ul style="list-style-type: none"> <li>• Off—No link is present.</li> <li>• Green—Link is active.</li> <li>• Green, flashing—Traffic is present on the active link.</li> </ul>	<b>6</b> Power supply: <ul style="list-style-type: none"> <li>• Off—No AC input (12-V main power off; 12-V standby power off)</li> <li>• Green, flashing—12-V main power off; 12-V standby power on.</li> <li>• Green—12-V main power on; 12-V standby power on.</li> <li>• Amber, flashing—Warning threshold detected but 12-V main power on.</li> <li>• Amber—Critical error detected; 12-V main power off ( for example, overcurrent, overvoltage, or overtemperature failure).</li> </ul>

# Power Supply

The power supply is hot-swappable. The Secure Web Appliance ships with two power supplies thus providing redundancy.



**Note** Make sure that one power supply is always active.

The following table lists the specifications for the 1050-W AC power supply (Cisco part number 341-0638-03).

**Table 2: 1050-W Power Supply Specifications**

Description	Specification
AC input voltage range	Nominal range: 100 to 120 V AC, 200 to 240 V AC Range: 90–132 V AC, 180–264 V AC
AC input frequency	Nominal range: 50–60 Hz Range: 47–63 Hz
Maximum AC input current	12.5 A peak at 100 V AC 6.0 A peak at 208 V AC
Maximum input volt amperes	1250 VA at 100 V AC
Maximum output power for each power supply	1050 W
Maximum inrush current	15 A (subcycle duration)
Maximum hold-up time	12 ms at 1050 W
Power supply output voltage	12 V DC
Power supply standby voltage	12 V DC
Efficiency rating	Climate Savers Platinum Efficiency (80 Plus Platinum certified)
Form factor	RSP2
Input connector	IEC320 C14

## Hardware Specifications

The following table lists the hardware specifications for the Secure Web Appliance S196, S396, S696, and S696F.

Table 3: S196, S396, S696, and S696F Hardware Specifications

Specification	S196	S396	S696	S696F
Weight	31 lb (14.06 kg)	33.5 lb (15.19 kg)	30.8 lb (13.97 kg)	52.2 lb (23.68 kg)
Dimensions (H x W x D)	1.7 x 16.89 x 29.8 inches (4.32 x 43.0 x 75.6 cm)		3.4 x 16.9 x 29.5 inches (8.64 x 42.92 x 74.93 cm)	
Temperature	Operating: 41 to 95°F (5 to 35°C) Derate the maximum temperature by 1°C for every 1000 ft (305 m) of altitude above sea level. Nonoperating: -40 to 149°F (-40 to 65°C) When stored or transported			
Relative humidity	Operating: 10 to 90% noncondensing Nonoperating: 5 to 93% noncondensing			
Altitude	Operating: 0 to 10,000 ft Nonoperating: 0 to 40,000 ft When stored or transported			
Sound power level	5.5 Bels (measure A-weighted per ISO7779 LWAd) Operation at 73°F (23°C)			
Sound pressure level	40 dBa (measure A-weighted per ISO7779 LpAM) Operation at 73°F (23°C)			

## Product ID (PID) Numbers

The following table lists the PIDs associated with Secure Web Appliance S196, S396, S696, and S696F. The spare components are ones that you can order and replace yourself. If any internal components fail, you must get an RMA for the entire chassis including the SFPs and SFP cables. Remove the drives and power supplies before you send the chassis for RMA. See the [Cisco Returns Portal](#) for more information.

Table 4: S196, S396, S696, and S696F PIDs

PID	Description
WSA-S196-K9	Cisco Secure Web Appliance S196 chassis 1 RU
WSA-S396-K9	Cisco Secure Web Appliance S396 chassis 1 RU
WSA-S696-K9	Cisco Secure Web Appliance S696 chassis 2 RU
WSA-S696F-K9	Cisco Secure Web Appliance S696F chassis 2 RU
UCS-HD12TB10K12N	S196, S396, S696, S696F HDD

PID	Description
UCS-HD12TB10K12N=	S196, S396, S696, S696F HDD (spare)
UCSC-PSU1-1050W	S196, S396, S696, S696F AC power supply
UCSC-PSU1-1050W=	S196, S396, S696, S696F AC power supply (spare)
UCSC-RAIL-M6	S195, S395, S695, S695F rail kit
UCSC-RAIL-M6=	S196, S396, S696, S696F rail kit (spare)
UCSC-BZL-C220M6	S196 and S396 1 RU locking faceplate
UCSC-BZL-C220M6=	S196 and S396 1 RU locking faceplate (spare)
UCSC-BZL-C240M6	S696 and S696F 2 RU locking faceplate
UCSC-BZL-C240M6=	S696 and S696F 2 RU locking faceplate (spare)
SFP-10G-SR	C696F 10-Gb SFP
SFP-10G-SR=	C696F 10-Gb SFP (spare)

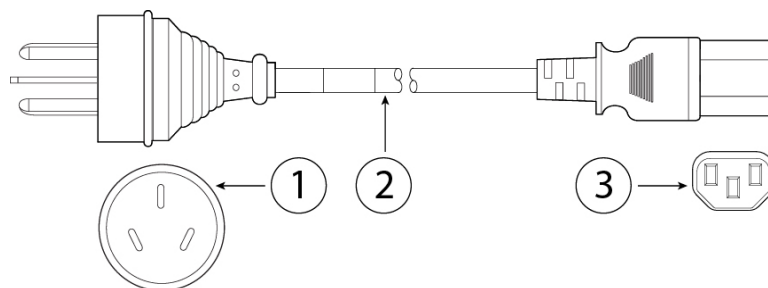
## Power Cord Specifications

Each power supply has a separate power cord. Standard power cords or jumper power cords are available for connection to the Secure Web Appliance. The jumper power cords for use in racks are available as an optional alternative to the standard power cords.

If you do not order the optional power cord with the system, you are responsible for selecting the appropriate power cord for the product. Using an incompatible power cord with this product may result in electrical safety hazard. Orders delivered to Argentina, Brazil, and Japan must have the appropriate power cord ordered with the system.

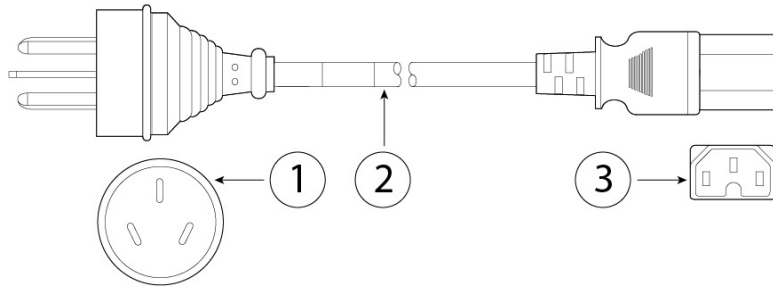
The following power cords and jumper cords are supported.

**Figure 14: Argentina (CAB-250V-10A-AR)**



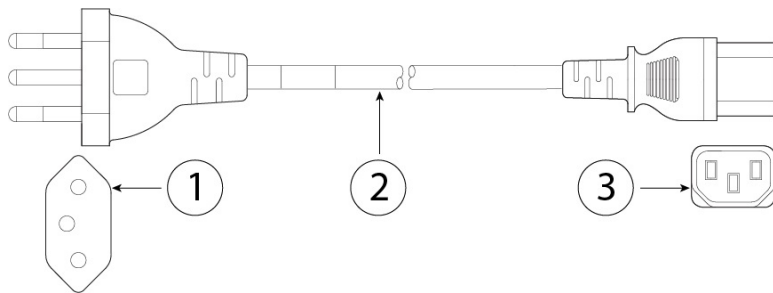
<b>1</b>	Plug: IRAM 2073	<b>2</b>	Cord set rating: 10 A, 250 V
<b>3</b>	Connector: IEC 60320/C13		—

**Figure 15: Australia (CAB-9K10A-AU)**



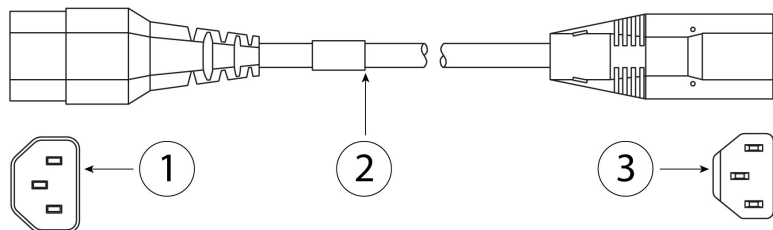
<b>1</b>	Plug: A.S. 3112-2000	<b>2</b>	Cord set rating: 10 A, 250 V
<b>3</b>	Connector: IEC 60320/C15		—

**Figure 16: Brazil (PWR-250V-10A-BZ)**



<b>1</b>	Plug: NBR 14136	<b>2</b>	Cord set rating: 10 A, 250 V
<b>3</b>	Connector: IEC 60320/C13		—

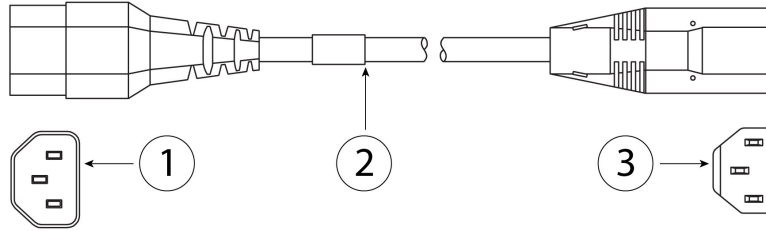
**Figure 17: Cabinet Jumper (CAB-C13-C14-2M)**



<b>1</b>	Plug: SS10A	<b>2</b>	Cord set rating: 10A, 250V
<b>3</b>	Connector: HS10S, C-13 to C-14		—

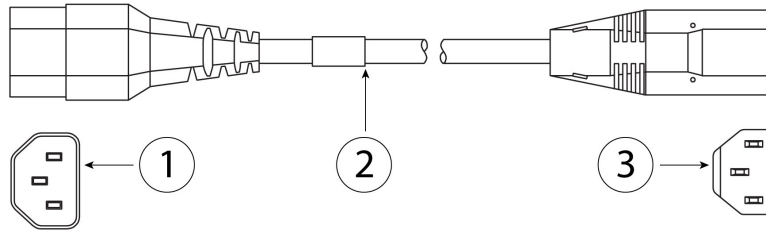


**Figure 18: Cabinet Jumper (CAB-C13-C14-AC)**



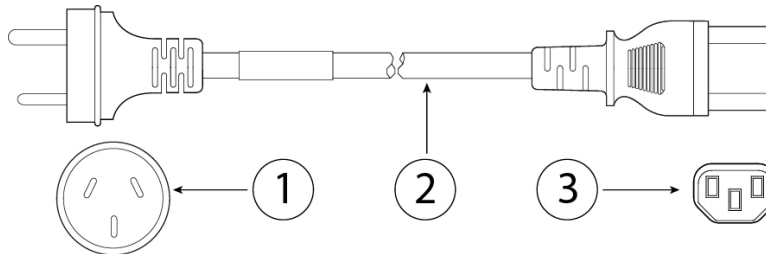
<b>1</b>	Plug: SS10A	<b>2</b>	Cord set rating: 10 A, 250 V
<b>3</b>	Connector: HS10S, C-13 to C-14 (recessed receptacle)		—

**Figure 19: Cabinet Jumper (CAB-C13-CBN)**



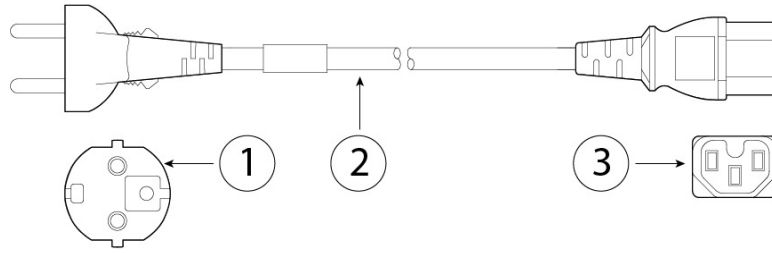
<b>1</b>	Plug: SS10A	<b>2</b>	Cord set rating: 10 A, 250 V
<b>3</b>	Connector: HS10S, C-13 to C-14		—

**Figure 20: China (CAB-250V-10A-CH)**



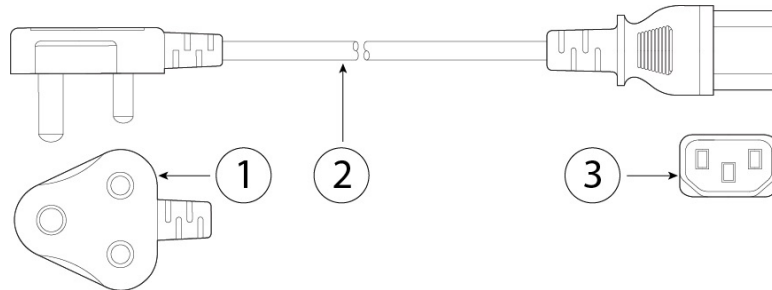
<b>1</b>	Plug: GB2099.1/2008	<b>2</b>	Cord set rating: 10 A, 250 V
<b>3</b>	Connector: IEC 60320/C13		—

**Figure 21: Europe (CAB-9K10A-EU)**



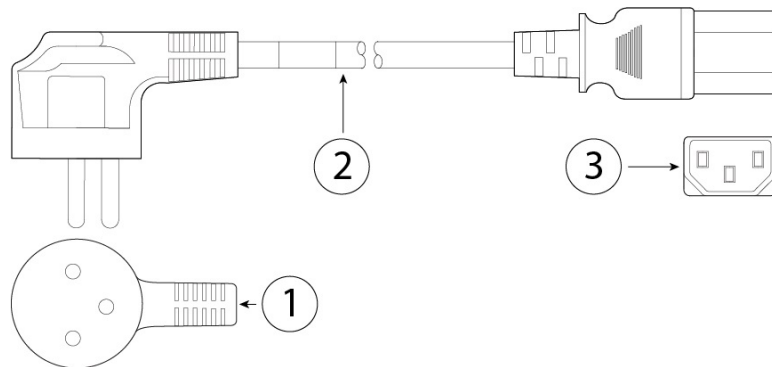
<b>1</b>	Plug: CEE 7/7 (M2511)	<b>2</b>	Cord set rating: 10 A/16 A, 250 V
<b>3</b>	Connector: IEC 60320/C15 (VSCC 15)		—

**Figure 22: India (CAB-250V-10A-ID)**



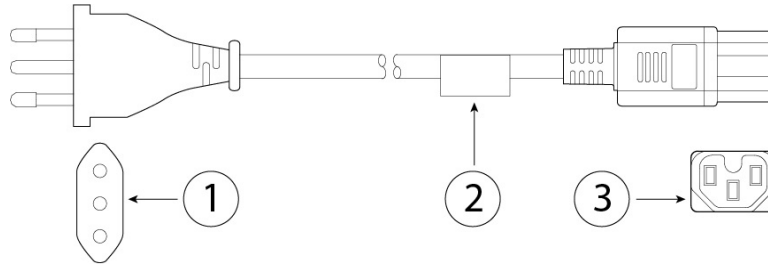
<b>1</b>	Plug: IS 6538-1971	<b>2</b>	Cord set rating: 16 A, 250 V
<b>3</b>	Connector: IEC 60320-C13		—

**Figure 23: Israel (CAB-250V-10A-IS)**



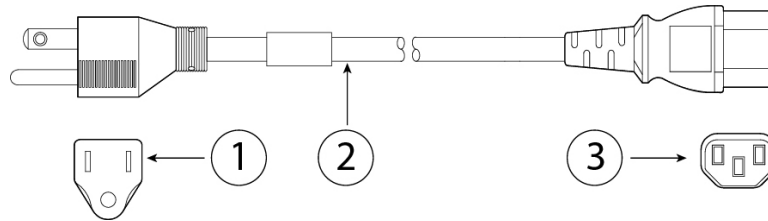
<b>1</b>	Plug: SI-32	<b>2</b>	Cord set rating: 10 A, 250 V
<b>3</b>	Connector: IEC 60320-C13		—

**Figure 24: Italy (CAB-9K10A-IT)**



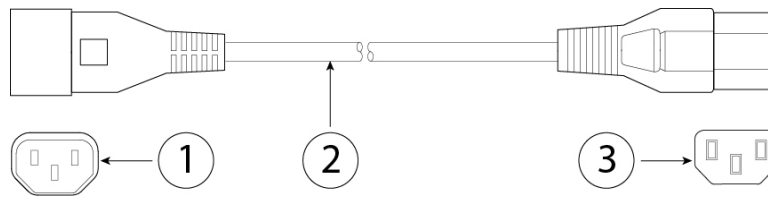
<b>1</b>	Plug: CEI 23-16/VII (I/3G)	<b>2</b>	Cord set rating: 10 A, 250 V
<b>3</b>	Connector: IEC 60320/C15 (EN 60320/C15M)		—

**Figure 25: Japan (CAB-JPN-3PIN)**



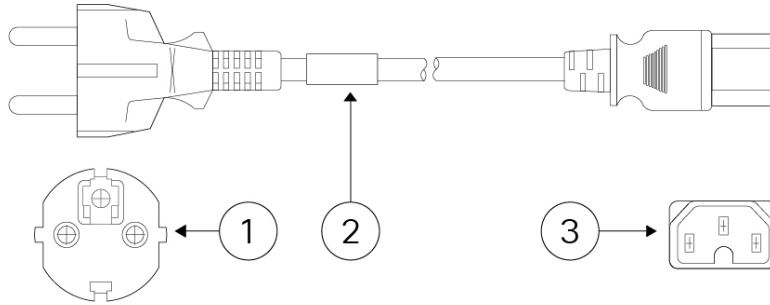
<b>1</b>	Plug: JIS 8303	<b>2</b>	Cord set rating: 12 A, 125 V
<b>3</b>	Connector: IEC 60320/C13		—

**Figure 26: Japan (CAB-C13-C14-2M-JP)**



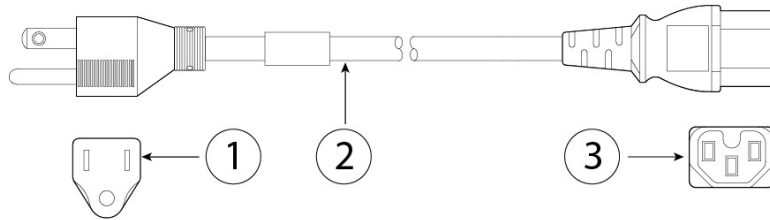
<b>1</b>	Plug: EN 60320-2-2/E	<b>2</b>	Cord set rating: 10 A, 250 V
<b>3</b>	Connector: EN 60320/C13 to C14		—

**Figure 27: Korea (CAB-9K10S-KOR)**



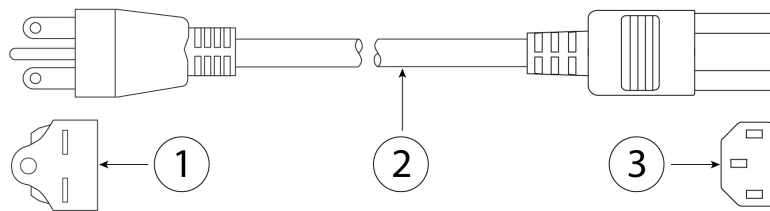
<b>1</b>	Plug: EL211 (KSC 8305)	<b>2</b>	Cord set rating: 10 A, 250 V
<b>3</b>	Connector: IEC 60320/C15		—

**Figure 28: North America (CAB-9K12A-NA)**



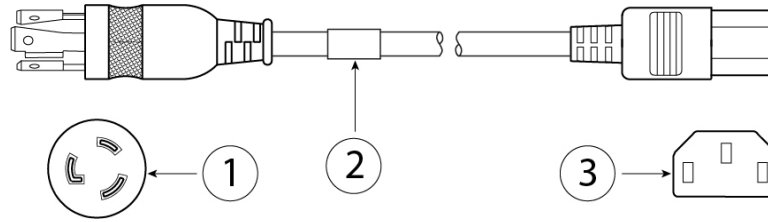
<b>1</b>	Plug: NEMA5-15P	<b>2</b>	Cord set rating: 13 A, 125 V
<b>3</b>	Connector: IEC 60320/C15		—

**Figure 29: North America (CAB-N5K6A-NA)**



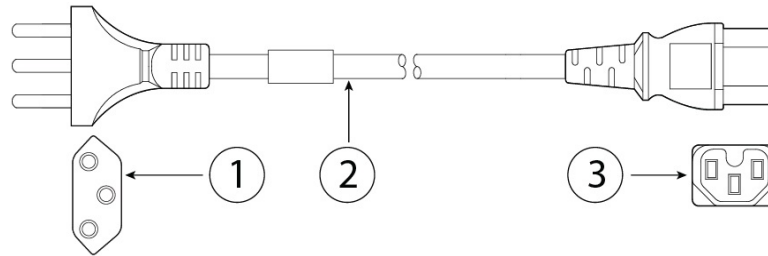
<b>1</b>	Plug: NEMA6-15P	<b>2</b>	Cord set rating: 10 A, 125 V
<b>3</b>	Connector: IEC 60320/C13		—

**Figure 30: North America (CAB-AC-L620-C13)**



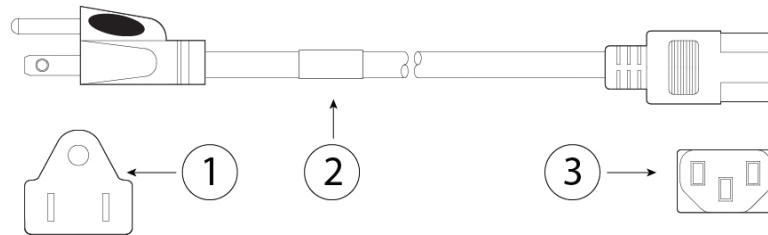
<b>1</b>	Plug: NEMA L6-20 (molded twist lock)	<b>2</b>	Cord set rating: 13 A, 250 V
<b>3</b>	Connector: IEC 60320/C13		—

**Figure 31: Switzerland (CAB-9K10A-SW)**



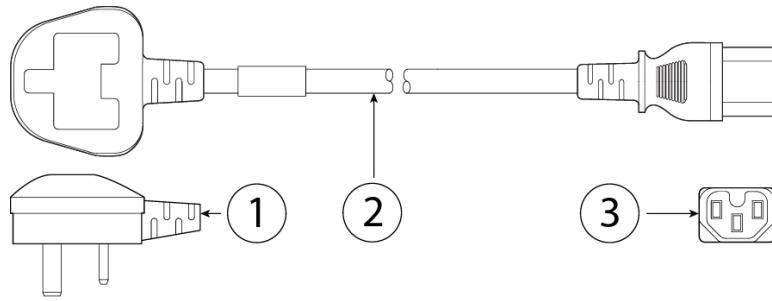
<b>1</b>	Plug: SEV 1011 (MP232-R)	<b>2</b>	Cord set rating: 10 A, 250 V
<b>3</b>	Connector: IEC 60320/C15		—

**Figure 32: Taiwan (CAB-ACTW)**



<b>1</b>	Plug: EL 302 (CNS10917)	<b>2</b>	Cord set rating: 10 A, 125 V
<b>3</b>	Connector: IEC 60320/C13		—

Figure 33: United Kingdom (CAB-9K10A-UK)



1	Plug: BS1363A/SS145	2	Cord set rating: 10 A, 250 V
3	Connector: IEC 60320/C15		—



## CHAPTER 2

# Installation Preparation

---

- [Installation Warnings, on page 27](#)
- [Safety Recommendations, on page 29](#)
- [Maintain Safety with Electricity, on page 30](#)
- [Prevent ESD Damage, on page 30](#)
- [Site Environment, on page 31](#)
- [Site Considerations, on page 31](#)
- [Power Supply Considerations, on page 31](#)
- [Rack Configuration Considerations, on page 32](#)

## Installation Warnings

Read the [Regulatory Compliance and Safety Information](#) document before installing the chassis.

Take note of the following warnings:



---

**Warning** **Statement 1071**—Warning Definition

**IMPORTANT SAFETY INSTRUCTIONS**

Before you work on any equipment, be aware of the hazards involved with electrical circuitry and be familiar with standard practices for preventing accidents. Read the installation instructions before using, installing, or connecting the system to the power source. Use the statement number at the beginning of each warning statement to locate its translation in the translated safety warnings for this device.

SAVE THESE INSTRUCTIONS





---

**Note** **Statement 407**—Japanese Safety Instruction

You are strongly advised to read the safety instruction before using the product.

<https://www.cisco.com/web/JP/techdoc/pldoc/pldoc.html>

When installing the product, use the provided or designated connection cables/power cables/AC adapters.

〈製品仕様における安全上の注意〉  
[www.cisco.com/web/JP/techdoc/index.html](http://www.cisco.com/web/JP/techdoc/index.html)

接続ケーブル、電源コードセット、ACアダプタ、バッテリーなどの部品は、必ず添付品または指定品をご使用ください。添付品・指定品以外をご使用になると故障や動作不良、火災の原因となります。また、電源コードセットは弊社が指定する製品以外の電気機器には使用できないためご注意ください。

---



---

**Warning** **Statement 1015**—Battery Handling

To reduce risk of fire, explosion or leakage of flammable liquid or gas:

- Replace the battery only with the same or equivalent type recommended by the manufacturer.
  - Do not dismantle, crush, puncture, use sharp tool to remove, short external contacts, or dispose of in fire.
  - Do not use if battery is warped or swollen.
  - Do not store or use battery in a temperature > 60° C.
  - Do not store or use battery in low air pressure environment < 69.7 kPa.
- 



---

**Warning** **Statement 1029**—Blank Faceplates and Cover Panels

Blank faceplates and cover panels serve three important functions: they reduce the risk of electric shock and fire, they contain electromagnetic interference (EMI) that might disrupt other equipment, and they direct the flow of cooling air through the chassis. Do not operate the system unless all cards, faceplates, front covers, and rear covers are in place.

---



---

**Warning** **Statement 1073**—No User-Serviceable Parts

There are no serviceable parts inside. To avoid risk of electric shock, do not open.

---



---

**Warning** **Statement 1074**—Comply with Local and National Electrical Codes

To reduce risk of electric shock or fire, installation of the equipment must comply with local and national electrical codes.

---





---

**Warning** **Statement 1089**—Instructed and Skilled Person Definitions

An instructed person is someone who has been instructed and trained by a skilled person and takes the necessary precautions when working with equipment.

A skilled person or qualified personnel is someone who has training or experience in the equipment technology and understands potential hazards when working with equipment.

There are no serviceable parts inside. To avoid risk of electric shock, do not open.

---



---

**Warning** **Statement 1090**—Installation by Skilled Person

Only a skilled person should be allowed to install, replace, or service this equipment. See statement 1089 for the definition of a skilled person.

There are no serviceable parts inside. To avoid risk of electric shock, do not open.

---



---

**Warning** **Statement 1091**—Installation by an Instructed Person

Only an instructed person or skilled person should be allowed to install, replace, or service this equipment. See statement 1089 for the definition of an instructed or skilled person.

There are no serviceable parts inside. To avoid risk of electric shock, do not open.

---



---

**Warning** **Statement 9001**—Product Disposal

Ultimate disposal of this product should be handled according to all national laws and regulations.

---

## Safety Recommendations

Observe these safety guidelines:

- Keep the area clear and dust free before, during, and after installation.
- Keep tools away from walkways, where you and others might trip over them.
- Do not wear loose clothing or jewelry, such as earrings, bracelets, or chains that could get caught in the chassis.
- Wear safety glasses if you are working under any conditions that might be hazardous to your eyes.
- Do not perform any action that creates a potential hazard to people or makes the equipment unsafe.
- Never attempt to lift an object that is too heavy for one person.

# Maintain Safety with Electricity



**Warning** Before working on a chassis, be sure the power cord is unplugged.

Follow these guidelines when working on equipment powered by electricity:

- Before beginning procedures that require access to the interior of the chassis, locate the emergency power-off switch for the room in which you are working. Then, if an electrical accident occurs, you can act quickly to turn off the power.
- Do not work alone if potentially hazardous conditions exist anywhere in your work space.
- Never assume that power is disconnected; always check.
- Look carefully for possible hazards in your work area, such as moist floors, ungrounded power extension cables, frayed power cords, and missing safety grounds.
- If an electrical accident occurs:
  - Use caution; do not become a victim yourself.
  - Disconnect power from the system.
  - If possible, send another person to get medical aid. Otherwise, assess the condition of the victim, and then call for help.
  - Determine whether the person needs rescue breathing or external cardiac compressions; then take appropriate action.
- Use the chassis within its marked electrical ratings and product usage instructions.
- The chassis is equipped with an AC-input power supply, which is shipped with a three-wire electrical cord with a grounding-type plug that fits into a grounding-type power outlet only. Do not circumvent this safety feature. Equipment grounding should comply with local and national electrical codes.

## Prevent ESD Damage

ESD occurs when electronic components are improperly handled, and it can damage equipment and impair electrical circuitry, which can result in intermittent or complete failure of your equipment.

Always follow ESD-prevention procedures when removing and replacing components. Ensure that the chassis is electrically connected to an earth ground. Wear an ESD-preventive wrist strap, ensuring that it makes good skin contact. Connect the grounding clip to an unpainted surface of the chassis frame to safely ground ESD voltages. To properly guard against ESD damage and shocks, the wrist strap and cord must operate effectively. If no wrist strap is available, ground yourself by touching the metal part of the chassis.

For safety, periodically check the resistance value of the antistatic strap, which should be between one and 10 megohms.

## Site Environment

See [Hardware Specifications, on page 17](#) for information about physical specifications.

To avoid equipment failures and reduce the possibility of environmentally caused shutdowns, plan the site layout and equipment locations carefully. If you are currently experiencing shutdowns or unusually high error rates with your existing equipment, these considerations may help you isolate the cause of failures and prevent future problems.

## Site Considerations

Considering the following helps you plan an acceptable operating environment for the chassis, and avoid environmentally-caused equipment failures.

- Electrical equipment generates heat. Ambient air temperature might not be adequate to cool equipment to acceptable operating temperatures without adequate circulation. Make sure that the room in which you operate your system has adequate air circulation.
- Ensure that the chassis cover is secure. The chassis is designed to allow cooling air to flow effectively within it. An open chassis allows air leaks, which may interrupt and redirect the flow of cooling air from the internal components.
- Always follow ESD-prevention procedures to avoid damage to equipment. Damage from static discharge can cause immediate or intermittent equipment failure.

## Power Supply Considerations

When installing the chassis, consider the following:

- Check the power at the site before installing the chassis to ensure that it is free of spikes and noise. Install a power conditioner, if necessary, to ensure proper voltages and power levels in the appliance-input voltage.
- Install proper grounding for the site to avoid damage from lightning and power surges.
- The chassis does not have a user-selectable operating range. Refer to the label on the chassis for the correct appliance input-power requirement.
- Several styles of AC-input power supply cords are available for the chassis; make sure that you have the correct style for your site.
- If you are using dual redundant (1+1) power supplies, we recommend that you use independent electrical circuits for each power supply.
- Install an uninterruptible power source for your site, if possible.

# Rack Configuration Considerations

See [Rack-Mount the Chassis, on page 34](#) for the procedure for rack-mounting the chassis.

Consider the following when planning a rack configuration:

- Standard 19-in. (48.3 cm) 4-post EIA rack with mounting rails that conform to English universal hole spacing according to section 1 of ANSI/EIA-310-D-1992.
- If you are mounting a chassis in an open rack, make sure that the rack frame does not block the intake or exhaust ports.
- If your rack includes closing front and rear doors, the doors must have 65 percent open perforated area evenly distributed from top to bottom to permit adequate airflow.
- Be sure enclosed racks have adequate ventilation. Make sure that the rack is not overly congested as each chassis generates heat. An enclosed rack should have louvered sides and a fan to provide cooling air.
- In an enclosed rack with a ventilation fan in the top, heat generated by equipment near the bottom of the rack can be drawn upward and into the intake ports of the equipment above it in the rack. Ensure that you provide adequate ventilation for equipment at the bottom of the rack.
- Baffles can help to isolate exhaust air from intake air, which also helps to draw cooling air through the chassis. The best placement of the baffles depends on the airflow patterns in the rack. Experiment with different arrangements to position the baffles effectively.



## CHAPTER 3

# Rack-Mount the Chassis

---

- [Unpack and Inspect the Chassis, on page 33](#)
- [Rack-Mount the Chassis, on page 34](#)

## Unpack and Inspect the Chassis



---

**Tip** Keep the shipping container in case the chassis requires shipping in the future. If any internal components fail, you must send your chassis back to us for RMA.

---



---

**Note** The chassis is thoroughly inspected before shipment. If any damage occurred during transportation or any items are missing, contact your customer service representative immediately.

---

See [Package Contents, on page 4](#) for a list of what shipped with the chassis.

- 
- Step 1** Remove the chassis from its cardboard container and save all packaging material.
- Step 2** Compare the shipment to the equipment list provided by your customer service representative. Verify that you have all items.
- Step 3** Check for damage and report any discrepancies or damage to your customer service representative. Have the following information ready:
- Invoice number of shipper (see the packing slip)
  - Model and serial number of the damaged unit. See [Serial Number Locations, on page 5](#) for the location of the serial number.
  - Description of damage
  - Effect of damage on the installation
-

# Rack-Mount the Chassis

## Before you begin

You can install the chassis in a rack using the Cisco rack kit (part number 800-43376-02).

The rack must be of the following type:

- A standard 19-inch (48.3-cm) wide, 4-post EIA rack with mounting posts that conform to English universal hole spacing per section 1 of ANSI/EIA-310-D-1992.
- The rack post holes can be square 0.38-inch (9.6 mm), round 0.28-inch (7.1 mm), #12-24 UNC, or #10-32 UNC when you use the supplied slide rails.
- The minimum vertical rack space per appliance must be 1 RU, equal to 1.75 inches (44.45 mm).
- The slide rails for the chassis have an adjustment range of 24 to 36 inches (610 to 914 mm).



---

**Note** The slide rails that ship with the chassis do not require tools for installation if you install them in a rack that has square 0.38-inch (9.6 mm), round 0.28-inch (7.1 mm), or #12-24 UNC threaded holes.

---

## Safety Warnings

Take note of the following warning:



---

**Warning** **Statement 1006**—Chassis Warning for Rack-Mounting and Servicing

To prevent bodily injury when mounting or servicing this unit in a rack, you must take special precautions to ensure that the system remains stable. The following guidelines are provided to ensure your safety:

- This unit should be mounted at the bottom of the rack if it is the only unit in the rack.
  - When mounting this unit in a partially filled rack, load the rack from the bottom to the top with the heaviest component at the bottom of the rack.
  - If the rack is provided with stabilizing devices, install the stabilizers before mounting or servicing the unit in the rack.
- 



---

**Warning** **Statement 1032**—Lifting the Chassis

To prevent personal injury or damage to the chassis, never attempt to lift or tilt the chassis using the handles on modules, such as power supplies, fans, or cards. These types of handles are not designed to support the weight of the unit.

---



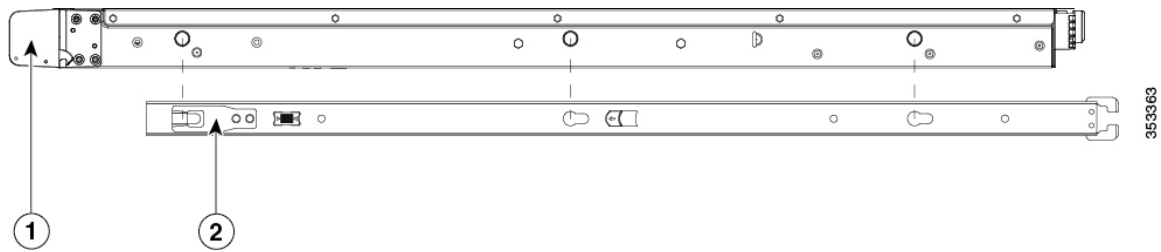
**Warning Statement 1098—Lifting Requirement**

Two people are required to lift the heavy parts of the product. To prevent injury, keep your back straight and lift with your legs, not your back.

**Step 1** Attach the inner rails to the sides of the chassis:

- a) Align an inner rail with one side of the chassis so that the three keyed slots in the rail align with the three pegs on the side of the chassis.
- b) Set the keyed slots over the pegs, and then slide the rail toward the front to lock it in place on the pegs. The front slot has a metal clip that locks over the front peg.
- c) Install the second inner rail to the opposite side of the chassis.

**Figure 34: Attach the Inner Rail to the Side of the Chassis**

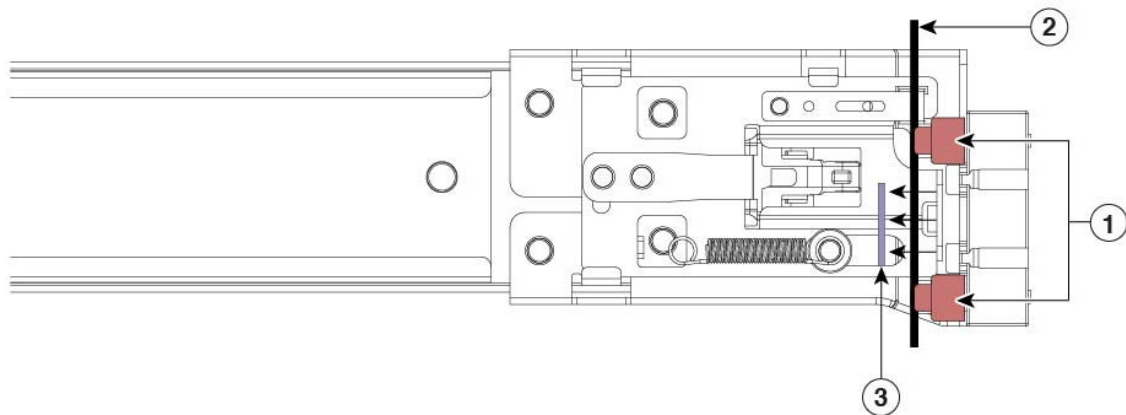


1	Front of chassis	2	Locking clip on inner rail
---	------------------	---	----------------------------

**Step 2** Open the front securing plate on both slide-rail assemblies. The front end of the slide-rail assembly has a spring-loaded securing plate that must be open before you can insert the mounting pegs into the rack-post holes.

On the outside of the assembly, push the green arrow button toward the rear to open the securing plate.

**Figure 35: Front Securing Mechanism on the Inside of Front End**



1	Front mounting pegs	2	Rack post
3	Securing plate shown pulled back to open position		—

**Step 3** Install the slide rails into the rack:

- a) Align one slide-rail assembly front end with the front rack-post holes that you want to use.

The slide rail front end wraps around the outside of the rack post and the mounting pegs enter the rack-post holes from the outside-front.

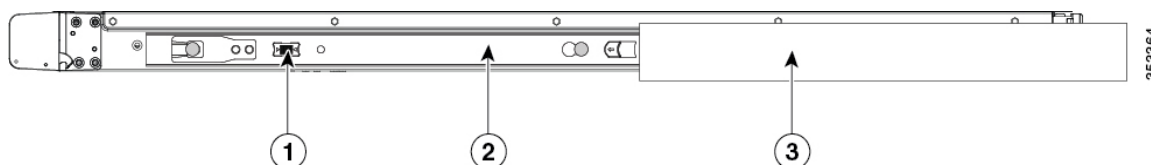
**Note** The rack post must be between the mounting pegs and the open securing plate.

- b) Push the mounting pegs into the rack-post holes from the outside-front.
- c) Press the securing plate release button, marked “PUSH.” The spring-loaded securing plate closes to lock the pegs in place.
- d) Attach the second slide-rail assembly to the opposite side of the rack. Make sure that the two slide-rail assemblies are at the same height with each other and are level front-to-back.
- e) Pull the inner slide rails on each assembly out toward the rack front until they hit the internal stops and lock in place.

**Step 4** Insert the chassis into the slide rails:

- a) Align the rear of the inner rails that are attached to the chassis sides with the front ends of the empty slide rails on the rack.
- b) Push the inner rails into the slide rails on the rack until they stop at the internal stops.
- c) Slide the release clip toward the rear on both inner rails, and then continue pushing the chassis into the rack until its front slam latches engage with the rack posts

**Figure 36: Inner Rail Release Clip**



1	Inner rail release clip	2	Inner rail attached to chassis and inserted into outer rail
3	Outer rail attached to rack post		

- Step 5** (Optional) Secure the chassis in the rack more permanently by using the two screws that are provided with the slide rails. Perform this step if you plan to move the rack with chassis installed. With the chassis fully pushed into the slide rails, open a hinged slam latch lever on the front of the chassis and insert the screw through the hole that is under the lever. The screw threads into the static part of the rail on the rack post and prevents the chassis from being pulled out. Repeat for the opposite slam latch.

**What to do next**

Install the cables according to your default software configuration as described in the [Getting Started Guide](#) for your software version.





## CHAPTER 4

# Maintenance and Upgrades

---

- [Power Button Shut Down, on page 37](#)
- [Enable RPC, on page 38](#)
- [Reset the Chassis Remotely, on page 39](#)
- [Install/Uninstall the Locking Faceplate, on page 39](#)
- [Remove and Replace a Drive, on page 40](#)
- [Remove and Replace a Power Supply, on page 43](#)

## Power Button Shut Down

The chassis runs in two modes:

- Main power mode—Power is supplied to all components and all operating systems can run.
- Standby power mode—Power is supplied only to the service processor and certain components. You can safely remove power cords from the chassis in this mode.



---

**Caution** After you shut down the chassis to standby power, electric current is still present in the chassis. To completely remove power as directed in some maintenance procedures, you must disconnect all power cords from all power supplies in the chassis.

---

You can shut down the chassis using the front panel Power button or software management.

---

**Step 1** Check the Power LED:

- Amber—The chassis is already in standby mode and you can safely remove power.
- Green—The chassis is in main power mode and you must shut it down before you can safely remove power.

**Step 2** Perform a graceful shutdown or a hard shutdown:

**Caution** To avoid data loss or damage to your operating system, perform a graceful shutdown of the operating system.

- Graceful shutdown—Press and release the Power button. The operating system performs a graceful shutdown and the chassis goes into standby mode. The power LED is amber.

- Emergency shutdown—Press and hold the Power button for four seconds to force the main power off and immediately enter standby mode.

**Step 3** If a maintenance procedure instructs you to completely remove power from the chassis, disconnect all power cords from the power supplies.

---

## Enable RPC

You must enable and configure RPC before you can remotely reset chassis power.

### Before you begin

- Cable the RPC port directly to a secure network.
  - Open necessary ports through the firewall to make sure the chassis is accessible remotely.
  - RPC requires a unique IPv4 address for the RPC port. You must use the following procedure to configure the RPC port. You cannot configure it using the **ipconfig** command.
  - To cycle chassis power you must have a third-party tool that supports the Intelligent Platform Management Interface (IPMI) version 2.0.
- 

**Step 1** Use SSH or the serial console port to access the CLI.

**Step 2** Log in using an account with Administrator access.

**Step 3** Enter the following commands:

```
remotepower
setup
```

**Step 4** Follow the prompts to specify the following:

- The dedicated IP address for the RPC port, netmask, and gateway.
- The username and password required to execute the **power-cycle** command.

These credentials are independent of other credentials used to access your appliance. Store this information for administrators who may need to set up RPC in the future.

**Step 5** Enter **commit** to save your changes.

**Step 6** Test your configuration to verify that you can remotely manage chassis power.

---

### What to do next

See [Reset the Chassis Remotely, on page 39](#) for the procedure for configuring remote chassis management.

## Reset the Chassis Remotely

If the chassis requires a hard reset, you can reboot the chassis remotely using a third-party IPMI tool.

### Before you begin

- You must enable RPC in advance. See [Enable RPC, on page 38](#) for the procedure.
- Only the following IPMI commands are supported. Refer to your IPMI tool documentation on how to use them.

**status, on, off, cycle, reset, diag, soft**

- Set up a utility that can manage devices using IPMI version 2.0.

---

**Step 1** Use IPMI to issue a supported power-cycling command to the IP address assign to the RPC port.

**Note** The RPC port must be configured with the required credentials. See [Enable RPC, on page 38](#) for more information.

For example, issue the following command from a UNIX computer with IPMI support:

```
ipmitool -I lan -H ip-address -U remoteresetuser -P password chassis power reset
```

**Step 2** Wait at least 11 minutes for the chassis to reboot.

---

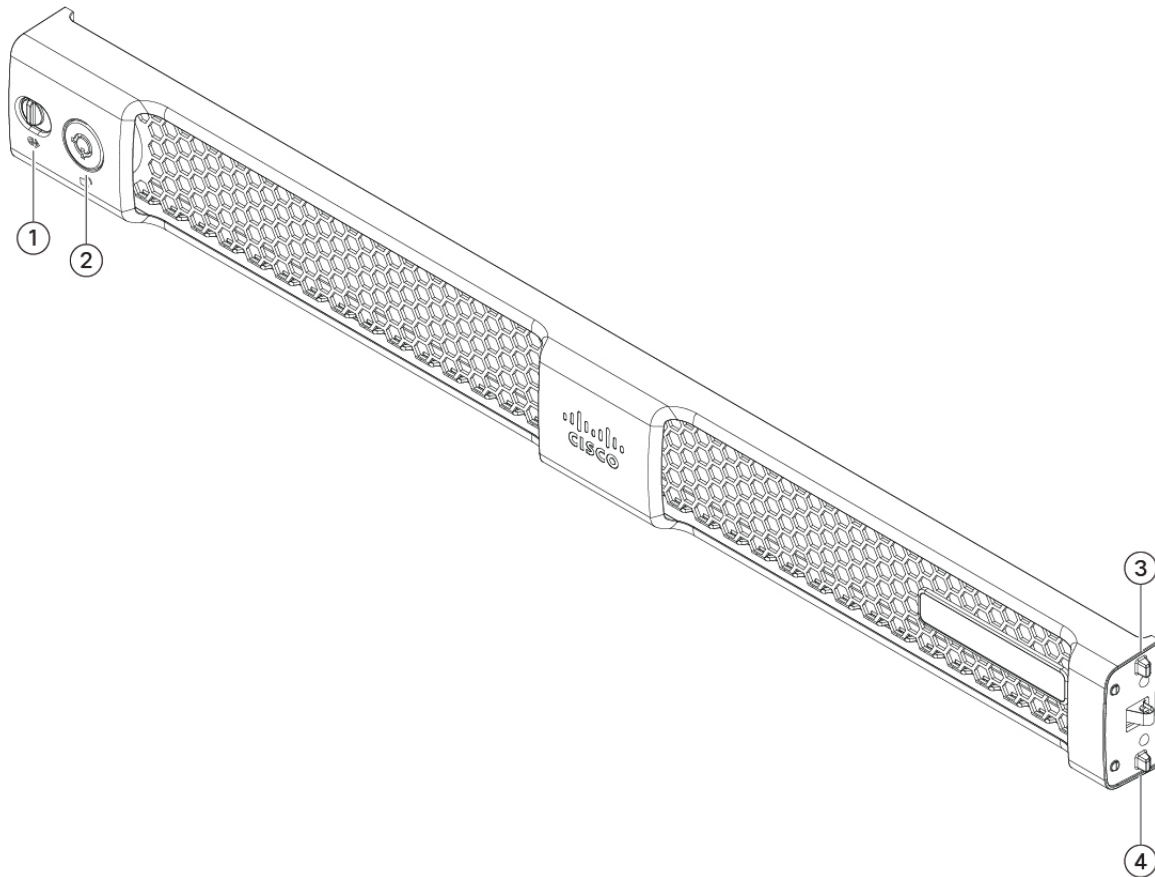
## Install/Uninstall the Locking Faceplate

The locking faceplate (Cisco part number 74-115098-01 for a 1 RU chassis and Cisco part number 74-115099-01 for a 2-RU chassis) ships with the key you need to lock the faceplate to the front panel of the chassis. The locking faceplate clicks in between the two side handles on the front panel.

---

**Step 1** Insert the right side of the locking faceplate by aligning the two plastic tabs with the two cutouts on the right side handle on the front of the chassis.

Figure 37: Locking Faceplate



1	Latch	2	Key hole
3	Spring-mounted tab	4	Spring-mounted tab

- Step 2** Press in the left side of the faceplate into the left side handle on the front panel. The tabs are spring-mounted to the latch, so they push in as the faceplate is installed.
- Step 3** Lock the faceplate using the key that shipped with the faceplate.
- Step 4** To uninstall the faceplate, unlock the faceplate, push the latch to the right, and pull the faceplate out.

## Remove and Replace a Drive

The drives are hot-swappable. You do not have to shut down the chassis to remove or replace drives.

You cannot add more drives to the chassis. You can only replace the drives in the slots that are supported for your model.

### Safety Warnings

Take note of the following warnings:



---

**Warning** **Statement 1073**—No User-Serviceable Parts

There are no serviceable parts inside. To avoid risk of electric shock, do not open.

---



---

**Warning** **Statement 1089**—Instructed and Skilled Person Definitions

An instructed person is someone who has been instructed and trained by a skilled person and takes the necessary precautions when working with equipment.

A skilled person or qualified personnel is someone who has training or experience in the equipment technology and understands potential hazards when working with equipment.

There are no serviceable parts inside. To avoid risk of electric shock, do not open.

---



---

**Warning** **Statement 1090**—Installation by Skilled Person

Only a skilled person should be allowed to install, replace, or service this equipment. See statement 1089 for the definition of a skilled person.

There are no serviceable parts inside. To avoid risk of electric shock, do not open.

---



---

**Warning** **Statement 1091**—Installation by an Instructed Person

Only an instructed person or skilled person should be allowed to install, replace, or service this equipment. See statement 1089 for the definition of an instructed or skilled person.

There are no serviceable parts inside. To avoid risk of electric shock, do not open.

---

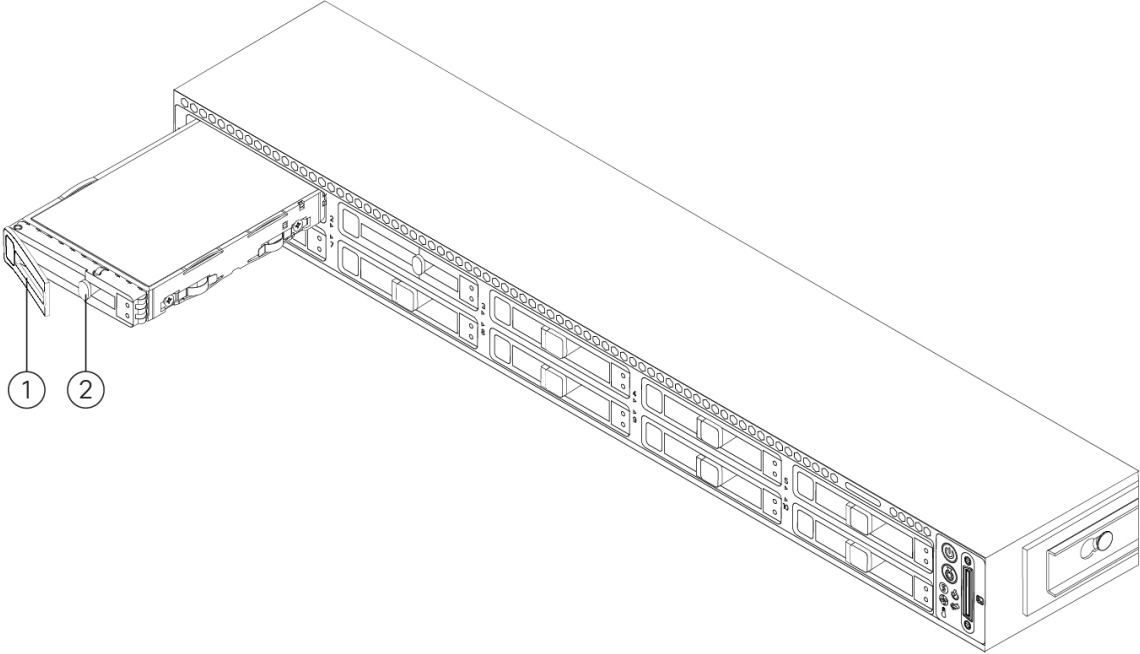
---

**Step 1**

Remove the drive that you are replacing:

- a) Press the release button on the face of the drive tray.
- b) Grasp and open the ejector lever and then pull the drive tray out of the slot.

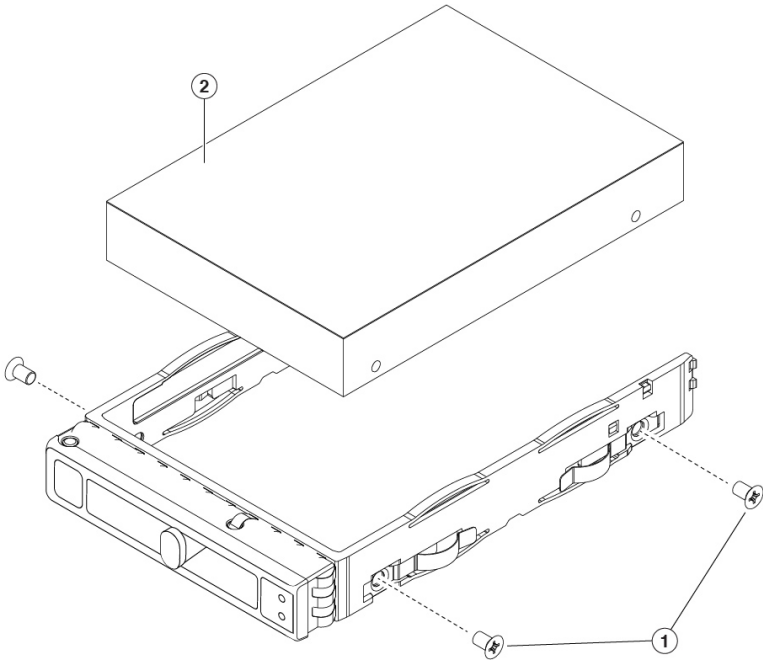
Figure 38: Remove the Drive



1	Ejector handle	2	Release button
---	----------------	---	----------------

**Step 2** Remove the four drive-tray screws that secure the drive to the tray and then lift the drive out of the tray.

Figure 39: Remove the Drive Tray



<b>1</b>	Drive tray screws ( two on each side)	<b>2</b>	Drive removed from drive tray
----------	---------------------------------------	----------	-------------------------------

**Step 3**

Install a new drive:

- a) Place a new drive in the empty drive tray and install the four drive-tray screws.
- b) With the ejector lever on the drive tray open, insert the drive tray into the empty drive bay.
- c) Push the tray into the slot until it touches the backplane, and then close the ejector lever to lock the drive in place.

## Remove and Replace a Power Supply

Two power supplies ship with the chassis; they are redundant and hot-swappable. One is the active power supply and the other is the standby power supply (1+1).



**Note** The Secure Web Appliance S196 ships with one power supply, but you can add another one for redundancy.

The chassis also supports cold redundancy. Depending on the power being drawn by the chassis, one power supply might actively provide all power to the system while the remaining power supply is put into a standby state. For example, if the power consumption can be satisfied by power supply 1, then power supply 2 is put into a standby state.



**Caution** When you replace power supplies, do not mix power supply types in the chassis. Both power supplies must be the same wattage and Cisco PID.



**Trouble** Power supply health monitoring notifies you if the power supply loses power or malfunctions so that redundancy is lost. Check the power supply cables to make sure they are functioning. If they are and errors are still occurring, replace the power supply.

### Safety Warnings

Take note of the following warnings:



**Warning** **Statement 1003**—DC Power Disconnection

To reduce risk of electric shock or personal injury, disconnect DC power before removing or replacing components or performing upgrades.




---

**Warning Statement 1005**—Circuit Breaker

This product relies on the building's installation for short-circuit (overcurrent) protection. Ensure that the protective device is rated not greater than:

AC 20 A

---




---

**Warning Statement 1017**—Restricted Area

This unit is intended for installation in restricted access areas. Only skilled, instructed, or qualified personnel can access a restricted access area.

---




---

**Warning Statement 1022**—Disconnect Device

To reduce the risk of electric shock and fire, a readily accessible disconnect device must be incorporated in the fixed wiring.

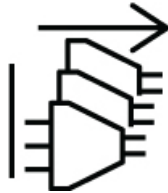
---




---

**Warning Statement 1028**—More Than One Power Supply

This unit might have more than one power supply connection. To reduce risk of electric shock, remove all connections to de-energize the unit.




---

**Warning Statement 1029**—Blank Faceplates and Cover Panels

Blank faceplates and cover panels serve three important functions: they reduce the risk of electric shock and fire, they contain electromagnetic interference (EMI) that might disrupt other equipment, and they direct the flow of cooling air through the chassis. Do not operate the system unless all cards, faceplates, front covers, and rear covers are in place.

---




---

**Warning Statement 1046**—Installing or Replacing the Unit

To reduce risk of electric shock, when installing or replacing the unit, the ground connection must always be made first and disconnected last.

If your unit has modules, secure them with the provided screws.

---

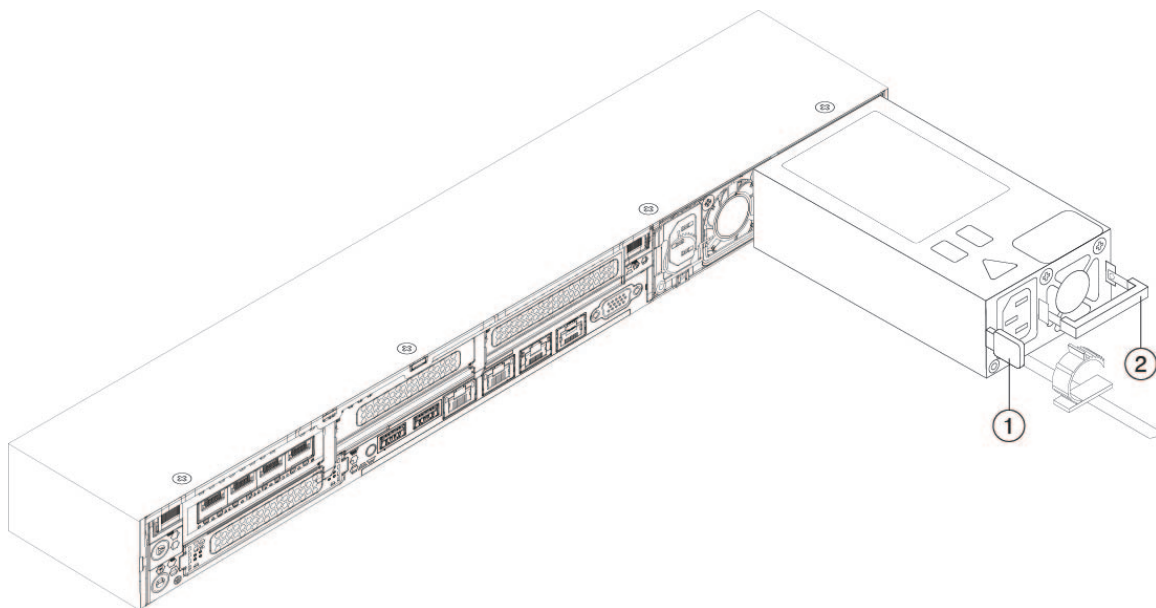


**Step 1**

Remove the power supply that you are replacing or the blank panel from an empty bay:

- a) Do one of the following actions:
  - If the chassis has one power supply, shut down and remove power from the chassis. See [Power Button Shut Down, on page 37](#) for the procedure.
  - If the chassis has two power supplies, you do not have to shut down the chassis.
- b) Remove the power cord from the power supply that you are replacing.
- c) Grasp the power supply handle while pinching the release lever toward the handle.
- d) Pull the power supply out of the bay.

**Figure 40: Remove and Replace the AC Power Supply**



<b>1</b>	Release lever	<b>2</b>	Handle
----------	---------------	----------	--------

**Step 2**

Install a new power supply:

- a) Grasp the power supply handle and insert the new power supply into the empty bay.
- b) Push the power supply into the bay until the release lever locks.
- c) Connect the power cord to the new power supply.
- d) If you shut down the chassis, press the Power button to return it to main power mode.

