



CHAPTER 3

Connecting the ISA 3000

This chapter describes how to connect the Cisco ISA 3000 Industrial Security Appliance to Ethernet devices and a network. The chapter contains the following sections:

- [Preparing to Connect the Cisco ISA 3000, page 3-1](#)
- [Connecting a PC to the ISA 3000 For Configuration., page 3-2](#)
- [Connecting to DC Power, page 3-3](#)
- [Verifying Connections, page 3-7](#)

Preparing to Connect the Cisco ISA 3000

Before you connect the Cisco ISA 3000 to the devices, install the ISA 3000 according to the instructions in [Chapter 2, “Installing the Cisco ISA 3000 Industrial Security Appliance”](#).



Caution

If this product will be installed in a hazardous location, read the Getting Started/Printed Document of Compliance included in the package.



Warning

To avoid electric shock, do not connect safety extra-low voltage (SELV) circuits to telephone-network voltage (TNV) circuits. LAN ports contain SELV circuits, and WAN ports contain TNV circuits. Some LAN and WAN ports both use RJ-45 connectors. Use caution when connecting cables. Statement 1021

Preventing Damage to the Cisco ISA 3000

Before installation, observe these general guidelines:

- Proper ESD protection should be observed
- Ensure the device is properly grounded
- Ensure there is proper airflow around the device

Connecting a PC to the ISA 3000 For Configuration.

There are two methods of connecting to the ISA 3000 and configuring the device:

- Connect a PC to the console connector of the Cisco ISA 3000 and launch a console terminal to use the CLI.
- Connect the PC to the Cisco ISA 3000 management sub-network which will then receive an IP address through DHCP. You can then launch ASDM to manage the device.

To connect a PC to the console port on the Cisco ISA 3000 and access the CLI, follow these steps:

Step 1 Choose which console connection will be used. In [Figure 3-1](#), Item 1 is the RJ-45 console connector, and item 2 is the mini-USB connector.

Figure 3-1 Console Connection Ports

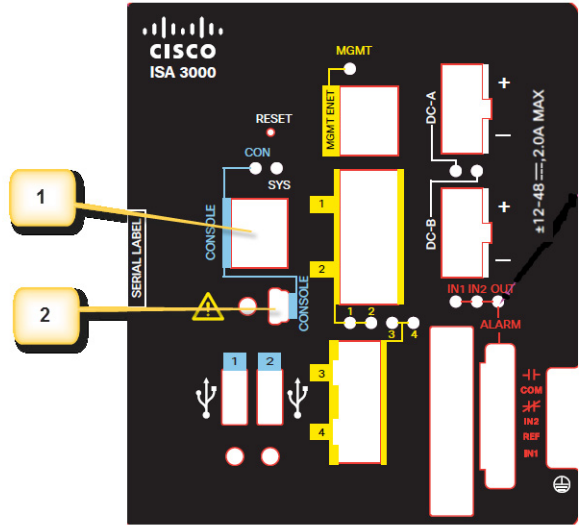

Step 2 If the mini-USB connector is being used, the protective cover will need to be removed first. The red arrow in [Figure 3-2](#) shows the location of the cover. Remove the cover with a Phillips screw driver and set it aside to be reinstalled after completing the configuration.

Figure 3-2 mini-USB Cover

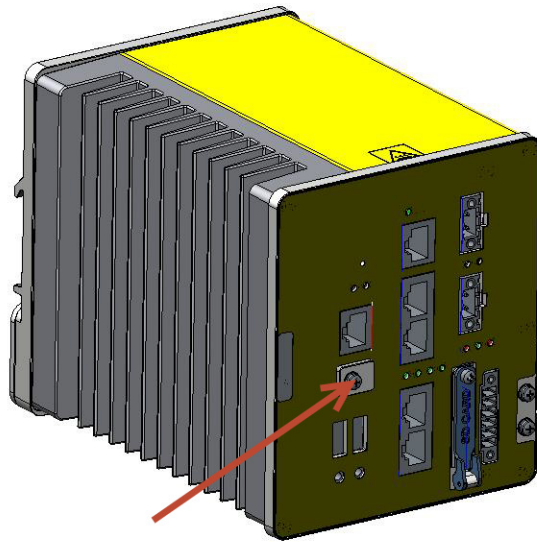

- Step 3** Connect the mini-USB side of a cable to the USB Console port on the Cisco ISA 3000.
- Step 4** Connect the opposite end of the mini-USB cable to the USB port on your PC.
- Step 5** If your PC warns you that you do not have the proper drivers to communicate with the router, you can obtain them from your computers manufacturer, or go here:
<https://www.silabs.com/products/mcu/Pages/USBtoUARTBridgeVCPDrivers.aspx>
- Step 6** Start up a console terminal.
- Step 7** See the initial configuration section for more details.

Connecting to DC Power



Warning

This product relies on the building's installation for short-circuit (overcurrent) protection. Ensure that the protective device is rated not greater than 60 VDC minimum, 5A maximum. Statement 1005



Warning

Installation of the equipment must comply with local and national electrical codes. Statement 1074

 **Warning**

Before performing any of the following procedures, ensure that power is removed from the DC circuit.
Statement 1003

 **Warning**

Only trained and qualified personnel should be allowed to install, replace, or service this equipment.
Statement 1030

 **Warning**

A readily accessible two-poled disconnect device must be incorporated in the fixed wiring.
Statement 1022

You connect DC power to the device through the front panel connectors. The device has a dual-feed DC power supply; two connectors provide primary and secondary DC power (DC-A and DC-B).

Each power connector has an LED status indicator. The device power connectors are attached to the device chassis. Each power connector has screw terminals for terminating the DC power. All connectors are attached to the device front panel with the provided captive screws.

The power connector labeling is on the panel. The positive DC power connection is labeled “+”, and the return connection is labeled “-”.

The device can operate with a single power source or with dual power sources. When both power sources are operational, the device draws power from the DC source with the higher voltage. If one of the two power sources fail, the other continues to power the device.

To connect DC power to your ISA 3000, follow these steps:

Step 1 Locate the two power connectors on the device front panel labeled DC-A and DC-B.

Figure 3-3 Power Connector

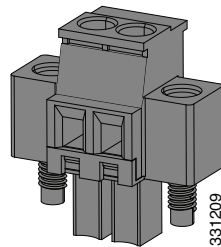

Step 2 Identify the connector positive and return DC power connections.

The labels for power connectors DC-A and DC-B are on the device panel as displayed in [Table 3-1](#).

Table 3-1 DC-A and DC-B Power Connector Labels

Label	Connection
+	Positive DC power connection
-	Return DC power connection

Step 3 Measure two strands of twisted-pair copper wire long enough to connect the power converter to the DC power source. For DC connections from the power converter to the DC source, use 18 to 20 AWG (2.6mm) twisted-pair copper wire.

Step 4 Using a 18-gauge (1.02mm) wire-stripping tool, strip the ground wire and both ends of the twisted pair wires to 0.25 inch (6.3 mm) ± 0.02 inch (0.5 mm). See [Figure 3-4](#), number 1. Do not strip more than 0.27 inch (6.8 mm) of insulation from the wires. Stripping more than the recommended amount of wire can leave exposed wire from the power and relay connector after installation.

Figure 3-4 Stripping the Power Connection Wire

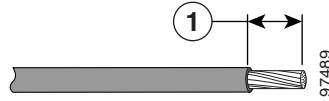

Step 5 Remove the two captive screws that attach the power connector to the device, and remove the power connector. Remove both connectors if you are connecting to two power sources

Step 6 On the power connector, insert the exposed part of the positive wire into the connection labeled “+” and the exposed part of the return wire into the connection labeled “-”. See [Figure 3-5](#).

Figure 3-5 Inserting Wires into the Power Connector

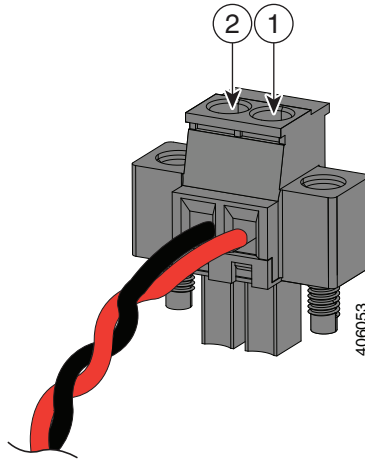

1	Power source positive connection	2	Power source return connection
----------	----------------------------------	----------	--------------------------------



Note Ensure that you cannot see any wire lead. Only wire with insulation should extend from the connector.

Step 7 Use a ratcheting torque flathead screwdriver to torque the power connector captive screws (above the installed wire leads) to 2 in-lb (0.23 N-m). See [Figure 3-6](#).



Note Do not over-torque the power connector’s captive screws. The torque should not exceed 2 inch-lbs (0.23 N-m).

Figure 3-6 Torquing the Power Connector Captive Screws

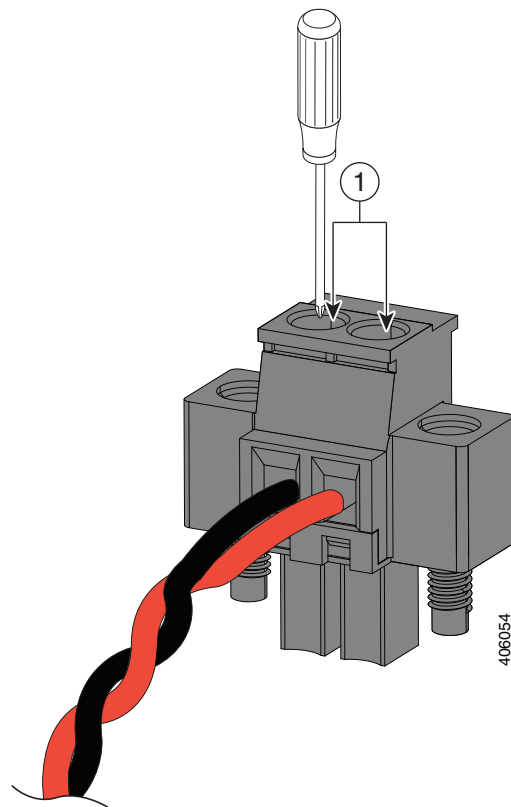

1	Power connector captive screws
----------	--------------------------------



Warning

An exposed wire lead from a DC-input power source can conduct harmful levels of electricity. Be sure that no exposed portion of the DC-input power source wire extends from the power and relay connector. Statement 122

Step 8

Connect the other end of the positive wire to the positive terminal on the DC power source, and connect the other end of the return wire to the return terminal on the DC power source.



Note

When you are testing the device, one power connection is sufficient. If you are installing the device and are using a second power source, repeat steps 4 through 8 using the second power connector.

Attaching the DC Power Connectors to the Device

To attach the power connectors to the front panel of the device, follow these steps:

- Step 1** Insert one power connector into the DC-A receptacle on the device front panel, and the other into the DC-B receptacle.

**Warning**

Failure to securely tighten the captive screws can result in an electrical arc if the connector is accidentally removed. Statement 397

**Warning**

When you connect or disconnect the power and/or alarm connector with power applied, an electrical arc can occur. This could cause an explosion in hazardous area installations. Be sure that all power is removed from the device and any other circuits. Be sure that power cannot be accidentally turned on or verify that the area is nonhazardous before proceeding. Statement 1058

- Step 2** Use a ratcheting torque flathead screwdriver to tighten the captive screws on the sides of the power connectors to 2 in-lb (0.23 N-m).
- Step 3** When you are testing the device, one power source is sufficient. If you are installing the device and are using a second power source, repeat this procedure for the second power connector (DC-B), which installs just below the primary power connector (DC-A).
- Step 4** When you are installing the device, secure the wires coming from the power connector so that they cannot be disturbed by casual contact. For example, use tie wraps to secure the wires to the rack.

Verifying Connections

To verify that all devices are properly connected to the Cisco ISA 3000, first turn on all the connected devices, then check the LEDs. To verify Cisco ISA 3000 operation, refer to the following table:

LED	Activity	Description
System	Power Status	Off — No power Green Steady on — Normal operation Green Flashing — Boot up phase and POST Red Flashing — BIOS Red — System is not functioning properly.
MGMT	Management Port Status	Off — No link (default) Green Steady on — Port link with no activity Green Flashing — Transmitting and Receiving data
DC_A DC_B	DC Power Status	Off — Power is not present Green Steady on — Power is present on the associated circuit. (Hardware controlled) Red Steady on — Power is not present on the associated circuit, and the system is configured for dual-input power.

LED	Activity	Description
Alarm Out	Alarm monitoring	Off — Alarm Out not configured or the system is off (Default) Green Steady on — Alarm Out is configured, no alarm detected. Red Steady on — Minor alarm detected Red Flashing — Major alarm detected
Alarm In 1&2	Alarm monitoring	Off — Alarm In not configured or the system is off (Default) Green Steady on — Alarm In is configured, no alarm detected. Red Steady on — Minor alarm detected Red Flashing — Major alarm detected
Ethernet Ports	Link Status	Off — No link Green Steady on — Link is up Green Flashing — Transmitting and Receiving data Amber — Fault, implies no link Port 1&2 or 3&4 LEDs flashing amber together — Those two ports are in bypass mode and the system is up.
Console	Console connection Status	Off — RJ-45 is being used for console Green — Mini USB is being used for console
BYPASS	Bypass Mode Indicator	The Ethernet LAN Ports pairs 1&2 or 3&4 (copper sku only) will blink amber together every 100ms (fast blink), when there is system power.