



Hardware Installation Guide for the Cisco 8100 Series Secure Routers

Cisco 8100 Secure Router Gen2
Updated April 24, 2026



© 2023–2025 Cisco Systems, Inc. All rights reserved.

Full Cisco Trademarks with Hardware License

THE SPECIFICATIONS AND INFORMATION REGARDING THE PRODUCTS IN THIS MANUAL ARE SUBJECT TO CHANGE WITHOUT NOTICE. ALL STATEMENTS, INFORMATION, AND RECOMMENDATIONS IN THIS MANUAL ARE BELIEVED TO BE ACCURATE BUT ARE PRESENTED WITHOUT WARRANTY OF ANY KIND, EXPRESS OR IMPLIED. USERS MUST TAKE FULL RESPONSIBILITY FOR THEIR APPLICATION OF ANY PRODUCTS.

THE SOFTWARE LICENSE AND LIMITED WARRANTY FOR THE ACCOMPANYING PRODUCT ARE SET FORTH IN THE INFORMATION PACKET THAT SHIPPED WITH THE PRODUCT AND ARE INCORPORATED HEREIN BY THIS REFERENCE. IF YOU ARE UNABLE TO LOCATE THE SOFTWARE LICENSE OR LIMITED WARRANTY, CONTACT YOUR CISCO REPRESENTATIVE FOR A COPY.

The following information is for FCC compliance of Class A devices: This equipment has been tested and found to comply with the limits for a Class A digital device, pursuant to part 15 of the FCC rules. These limits are designed to provide reasonable protection against harmful interference when the equipment is operated in a commercial environment. This equipment generates, uses, and can radiate radio-frequency energy and, if not installed and used in accordance with the instruction manual, may cause harmful interference to radio communications. Operation of this equipment in a residential area is likely to cause harmful interference, in which case users will be required to correct the interference at their own expense.

The following information is for FCC compliance of Class B devices: This equipment has been tested and found to comply with the limits for a Class B digital device, pursuant to part 15 of the FCC rules. These limits are designed to provide reasonable protection against harmful interference in a residential installation. This equipment generates, uses and can radiate radio frequency energy and, if not installed and used in accordance with the instructions, may cause harmful interference to radio communications. However, there is no guarantee that interference will not occur in a particular installation. If the equipment causes interference to radio or television reception, which can be determined by turning the equipment off and on, users are encouraged to try to correct the interference by using one or more of the following measures:

- Reorient or relocate the receiving antenna.
- Increase the separation between the equipment and receiver.
- Connect the equipment into an outlet on a circuit different from that to which the receiver is connected.
- Consult the dealer or an experienced radio/TV technician for help.

Modifications to this product not authorized by Cisco could void the FCC approval and negate your authority to operate the product.

The Cisco implementation of TCP header compression is an adaptation of a program developed by the University of California, Berkeley (UCB) as part of UCB's public domain version of the UNIX operating system. All rights reserved. Copyright © 1981, Regents of the University of California.

NOTWITHSTANDING ANY OTHER WARRANTY HEREIN, ALL DOCUMENT FILES AND SOFTWARE OF THESE SUPPLIERS ARE PROVIDED "AS IS" WITH ALL FAULTS. CISCO AND THE ABOVE-NAMED SUPPLIERS DISCLAIM ALL WARRANTIES, EXPRESSED OR IMPLIED, INCLUDING, WITHOUT LIMITATION, THOSE OF MERCHANTABILITY, FITNESS FOR A PARTICULAR PURPOSE AND NONINFRINGEMENT OR ARISING FROM A COURSE OF DEALING, USAGE, OR TRADE PRACTICE.

IN NO EVENT SHALL CISCO OR ITS SUPPLIERS BE LIABLE FOR ANY INDIRECT, SPECIAL, CONSEQUENTIAL, OR INCIDENTAL DAMAGES, INCLUDING, WITHOUT LIMITATION, LOST PROFITS OR LOSS OR DAMAGE TO DATA ARISING OUT OF THE USE OR INABILITY TO USE THIS MANUAL, EVEN IF CISCO OR ITS SUPPLIERS HAVE BEEN ADVISED OF THE POSSIBILITY OF SUCH DAMAGES.

Any Internet Protocol (IP) addresses and phone numbers used in this document are not intended to be actual addresses and phone numbers. Any examples, command display output, network topology diagrams, and other figures included in the document are shown for illustrative purposes only. Any use of actual IP addresses or phone numbers in illustrative content is unintentional and coincidental.

All printed copies and duplicate soft copies of this document are considered uncontrolled. See the current online version for the latest version.

Cisco has more than 200 offices worldwide. Addresses and phone numbers are listed on the Cisco website at www.cisco.com/go/offices.

Cisco and the Cisco logo are trademarks or registered trademarks of Cisco and/or its affiliates in the U.S. and other countries. To view a list of Cisco trademarks, go to this URL: <https://www.cisco.com/c/en/us/about/legal/trademarks.html>. Third-party trademarks mentioned are the property of their respective owners. The use of the word partner does not imply a partnership relationship between Cisco and any other company. (1721R)

Topics included

Full Cisco Trademarks with Hardware License.....	iii
1 Introduction to Cisco 8100 Series Secure Routers.....	7
Cisco 8100 Series Secure Routers.....	8
Chassis views.....	9
Power supply.....	15
Install the router with a PSU on a rack tray.....	15
LED indicators.....	17
Reset button.....	18
Slots and interfaces.....	18
Periodic inspection and cleaning.....	19
2 Prepare for Installation.....	21
Prepare for router installation.....	22
Safety recommendations.....	22
General site requirements.....	23
Site selection guidelines.....	27
Rack requirements.....	28
Power guidelines and requirements.....	28
Safety with electricity.....	28
Prevent electrostatic discharge damage.....	29
Network cabling specifications.....	29
Console port considerations.....	29
EIA/TIA-232.....	29
Ethernet connections.....	30
Required tools and equipment for installation and maintenance.....	30
3 Install 8100 Series Secure Routers.....	31
Install and connect.....	32
Unpack the router.....	32
Items shipped with your router.....	32
Install the router.....	32
Desktop.....	34
Rack mount.....	34
Under desk or shelf mount.....	42
Wall mount.....	52
Chassis grounding.....	68
Ground connection warnings.....	71

Optical connection SFP warnings.....	71
Connect the power cable.....	72
Connect the router to a console.....	74
Connect to the serial port with Microsoft Windows.....	75
Connect to the console port with Mac OS X.....	75
Connect to the console port with Linux.....	76
Connect WAN and LAN interfaces.....	76

4 Install and Upgrade Field Replaceable Units.....79

Install a Pluggable Interface Module.....	80
Insert antenna into the Pluggable Interface Module.....	84
Antenna connector details for embedded 5G devices.....	86
RF band mapping for antenna ports.....	87
Insert Micro-SIM into a Pluggable Interface Module.....	88
LED behaviors.....	89
Install a Nano-SIM card into the router.....	91
Removal of SFP-10G-ONT20-I XGSPON optical module.....	96

1 Introduction to Cisco 8100 Series Secure Routers

Topics:

- [Cisco 8100 Series Secure Routers](#)
- [Chassis views](#)
- [Power supply](#)
- [LED indicators](#)
- [Reset button](#)
- [Slots and interfaces](#)
- [Periodic inspection and cleaning](#)

Cisco 8100 Series Secure Routers

Describes the main functions, features, and capabilities of Cisco 8100 Series Secure Routers, providing foundational understanding of their role and use cases within secure network infrastructures.

The Cisco 8100 Series Secure Routers offer secure branch connectivity to customers connecting small branch and remote locations to their enterprise networks over a diverse set of interfaces. This allows users and devices at these locations to access enterprise applications hosted at the campus, headquarters, data centers, or the cloud. The Cisco 8100 Series Secure Routers are the next generation, IOS XE based, multi-core, branch routers. These platforms are fixed with some pluggable cellular options.

Table 1: Base Models of the Cisco 8100 Series Secure Routers

Base Models	LAN Ports Only	WAN Ports Only	Flex L2/L3 Ports	Console Ports	Power Supply	DRAM, Flash	Storage	PoE/PoE+	Cellular Connectivity
C8130-G2	2xGE RJ45	1xGE RJ45 1xGE RJ45/SFP combo	2xGE RJ45	1xRJ45 console	30W/66W	4 GB 16 GB	USB Type C 3.0	None	None
C8131-G2	2xGE RJ45	1xGE RJ45 1xGE RJ45/SFP combo	2xGE RJ45	1xRJ45 console	30W/66W	8 GB 16 GB	USB Type C 3.0	None	None
C8140-G2	6xGE RJ45	2xGE RJ45/SFP combo	2xGE RJ45	1xRJ45 console	66W	4 GB 16 GB	USB Type C 3.0	None	None
C8151-G2	6xGE RJ45	2xGE RJ45/SFP combo	2xGE RJ45	1xRJ45 console	66W	8 GB 16 GB	USB Type C 3.0	None	5G Standalone/CAT 7 LTE (Pluggable)
C8161-G2	6xGE RJ45	2xGE RJ45/SFP combo	2xGE RJ45	1xRJ45 console	150W	8 GB 16 GB	USB Type C 3.0	4PoE/2PoE+	5G Standalone/CAT 7 LTE (Pluggable)
C8130-VAI-G2	2xGE RJ45	RJ11 DSL 1xGE RJ45/SFP combo 1xGE RJ45/SFP combo	2xGE RJ45	1xRJ45 console	66W	4GB 16GB	USB Type-C 3.0	None	None
C8130-VAP-G2	2xGE RJ45	RJ11 DSL 1xGE RJ45/SFP combo 1xGE RJ45/SFP combo	2xGE RJ45	1xRJ45 console	66W	4GB 16GB	USB Type-C 3.0	None	None

Base Models	LAN Ports Only	WAN Ports Only	Flex L2/L3 Ports	Console Ports	Power Supply	DRAM, Flash	Storage	PoE/PoE+	Cellular Connectivity
C8151-CVAI-G2	6xGE RJ45	RJ11 DSL 1xGE RJ45/SFP combo	2xGE RJ45	1xRJ45 console	66W	8GB 16GB	USB Type-C 3.0	None	Embedded 5G Release-17
C8151-CVAP-G2	6xGE RJ45	RJ11 DSL 1xGE RJ45/SFP combo	2xGE RJ45	1xRJ45 console	66W	8GB 16GB	USB Type-C 3.0	None	Embedded 5G Release-17

Table 2: Supported RF Bands

Base Models	5G NR Sub-6 Frequency Bands	4G LTE Frequency Bands
C8151-CVAI-G2	1, 2, 3, 5, 7, 8, 12, 13, 14, 18, 20, 25, 26, 28, 30, 38, 40, 41, 48, 66, 70, 71, 77, 78, 79	1, 2, 3, 4, 5, 7, 8, 12, 13, 14, 17, 18, 19, 20, 25, 26, 28, 30, 34, 38, 39, 40, 41, 42, 43, 48, 66, 70, 71, 106
P-5GS6-R16SA-GL	1, 2, 3, 5, 7, 8, 12, 13, 14, 18, 20, 25, 26, 28, 29, 30, 38, 39, 40, 41, 48, 66, 70, 71, 75, 76, 77, 78, 79	1, 2, 3, 4, 5, 7, 8, 12, 13, 14, 18, 19, 20, 21, 25, 26, 28, 29, 30, 32, 34, 38, 39, 40, 41, 42, 43, 46, 48, 66, 71

Table 3: Pluggable Modules of the Cisco 8100 Series Secure Routers

Pluggable Interface Modules (PIM)	Pluggable Interface Modules (PIM) Technology
P-5GS6-R16SA-GL	5G Sub-6 GHz Pluggable Interface Module
P-LTEA7-NA	CAT7 LTE Pluggable for North America
P-LTEA7-JP	CAT7 LTE Advanced PIM for Japan
P-LTEA7-EAL	CAT7 LTE Advanced PIM for EMEA, APAC, LATAM

Chassis views

Details the physical layout and components of the router chassis, highlighting front and rear panels, key visual elements, and overall hardware structure for easier identification and maintenance.

This section contains front and back panel views of the Cisco 8100 Series Secure Routers showing locations of the power and signal interfaces, interface slots, status indicators, and chassis identification labels.

Figure 1: C8130-G2- Rear view



- 1 System status
- 2 VPN

Figure 2: C8130-G2 - Front view

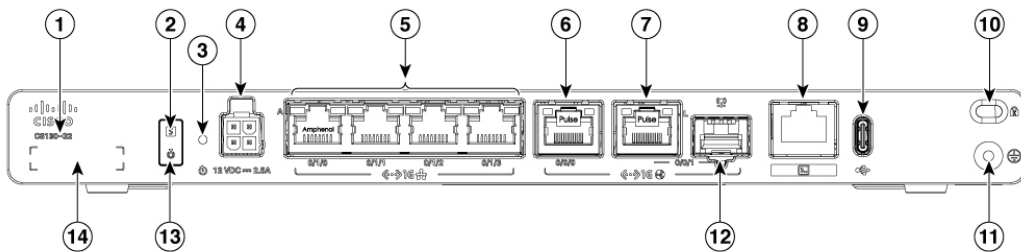

- 1 Product Identification Number (PID)
- 2 System status
- 3 Reset button
- 4 4-Pin power connector
- 5 GE RJ45 0/1/0 to 0/1/3
- 6 GE 0/0/0 - RJ45
- 7 GE 0/0/1 - RJ45
- 8 RJ45 console port
- 9 USB-C 3.0
- 10 Kensington lock slot
- 11 Grounding
- 12 GE 0/0/1 - SFP
- 13 Blue beacon
- 14 Serial number

Figure 3: C8131-G2- Rear view



- 1 System status
- 2 VPN

Figure 4: C8131-G2 - Front view

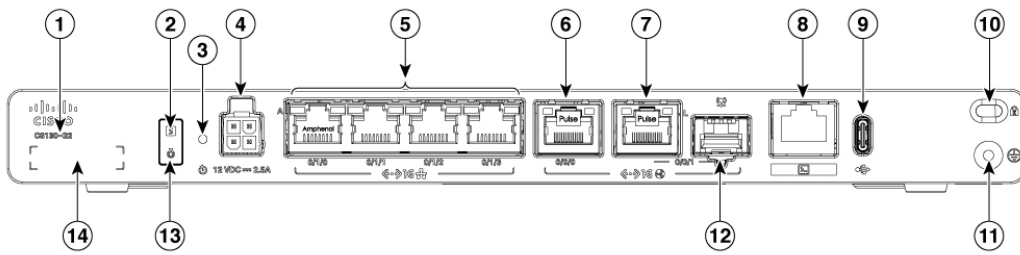

- | | | | |
|----|-------------------------------------|----|-----------------------|
| 1 | Product Identification Number (PID) | 2 | System status |
| 3 | Reset button | 4 | 4-Pin power connector |
| 5 | GE RJ45 0/1/0 to 0/1/3 | 6 | GE 0/0/0 - RJ45 |
| 7 | GE 0/0/1 - RJ45 | 8 | RJ45 console port |
| 9 | USB-C 3.0 | 10 | Kensington lock slot |
| 11 | Grounding | 12 | GE 0/0/1 - SFP |
| 13 | Blue beacon | 14 | Serial number |

Figure 5: C8140-G2- Rear view



- | | | | |
|---|---------------|---|-----|
| 1 | System status | 2 | VPN |
|---|---------------|---|-----|

Figure 6: C8140-G2 - Front view

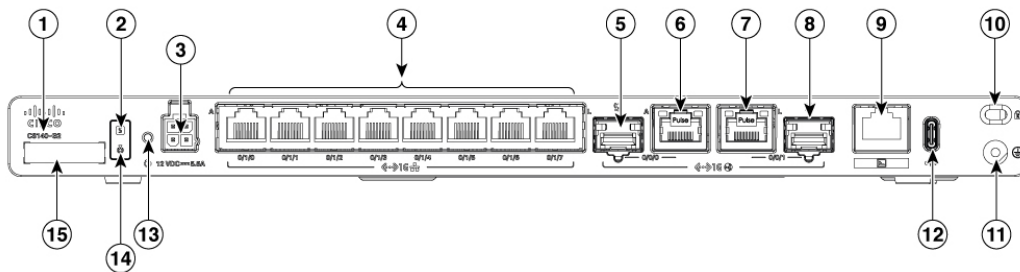

- | | | | |
|---|-------------------------------------|----|------------------------|
| 1 | Product Identification Number (PID) | 2 | System status |
| 3 | 4-Pin power connector | 4 | GE RJ45 0/1/0 to 0/1/7 |
| 5 | GE 0/0/0 - SFP | 6 | GE 0/0/0 - RJ45 |
| 7 | GE 0/0/1 - RJ45 | 8 | GE 0/0/1 - SFP |
| 9 | RJ45 console port | 10 | Kensington lock slot |

- | | | | |
|----|---------------|----|-------------|
| 11 | Grounding | 12 | USB-C 3.0 |
| 13 | Reset button | 14 | Blue beacon |
| 15 | Serial number | | |

Figure 7: C8151-G2 - Rear view



- | | | | |
|---|---------------|---|-----|
| 1 | System status | 2 | VPN |
|---|---------------|---|-----|

Figure 8: C8151-G2 - Front view

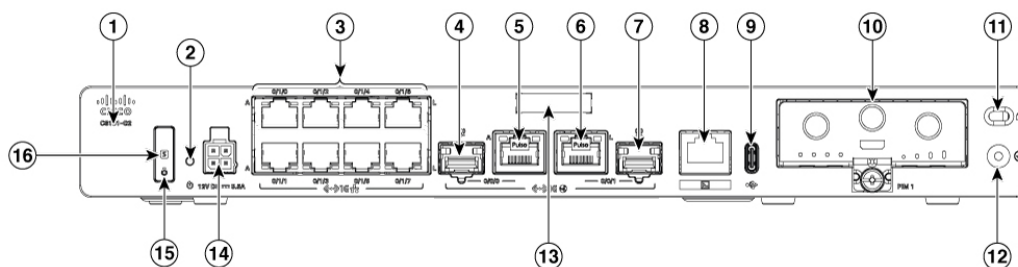

- | | | | |
|----|-------------------------------------|----|-----------------------|
| 1 | Product Identification Number (PID) | 2 | Reset button |
| 3 | GE RJ45 0/1/0 to 0/1/7 | 4 | GE 0/0/0 - SFP |
| 5 | GE 0/0/0 - RJ45 | 6 | GE 0/0/1 - RJ45 |
| 7 | GE 0/0/1 - SFP | 8 | RJ45 console port |
| 9 | USB-C 3.0 | 10 | PIM module |
| 11 | Kensington lock slot | 12 | Grounding |
| 13 | Serial number | 14 | 4-Pin power connector |
| 15 | Blue beacon | 16 | System status |

Figure 9: C8161-G2 - Rear view



- 1 System status
- 2 VPN

Figure 10: C8161-G2 - Front view

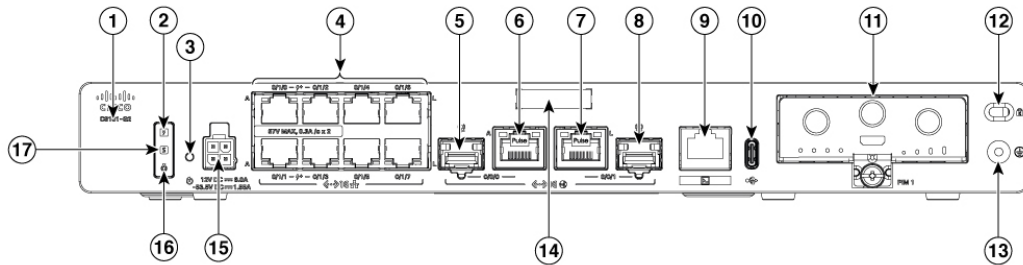

- 1 Product Identification Number (PID)
- 2 POE PSU status LED
- 3 Reset button
- 4 GE RJ45 0/1/0 to 0/1/7
- 5 GE 0/0/0 - SFP
- 6 GE 0/0/0 - RJ45
- 7 GE 0/0/1 - RJ45
- 8 GE 0/0/1 - SFP
- 9 RJ45 console port
- 10 USB-C 3.0
- 11 PIM module
- 12 Kensington lock slot
- 13 Grounding
- 14 Serial number
- 15 4-Pin power connector
- 16 Blue beacon
- 17 System status

Figure 11: C8130-VAI-G2 and C8130-VAP-G2 - Rear view



- 1 System status
- 2 VPN

Figure 12: C8130-VAI-G2 and C8130-VAP-G2 - Front view

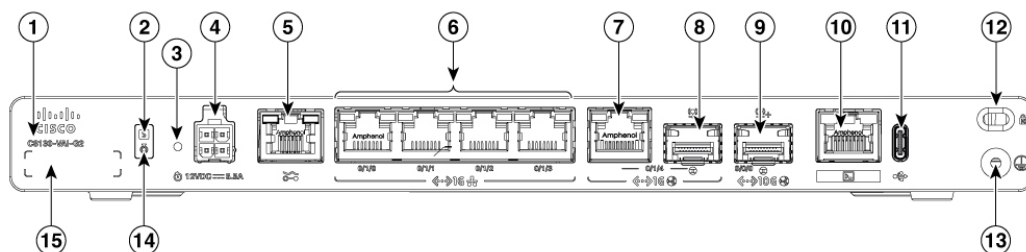

- 1 Product Identification Number (PID)
- 2 System status

- | | | | |
|----|-----------------------------|----|------------------------|
| 3 | Reset button | 4 | 4-Pin power connector |
| 5 | RJ11 DSL Port | 6 | GE RJ45 0/1/0 to 0/1/3 |
| 7 | GE 0/1/4 - RJ45 | 8 | GE 0/1/4 - SFP |
| 9 | TE 0/0/0 - XGSPON/10GBASE-T | 10 | RJ45 console port |
| 11 | USB-C 3.0 | 12 | Kensington lock slot |
| 13 | Grounding | 14 | Blue beacon |
| 15 | Serial number | | |

Figure 13: C8151-CVAI-G2 and C8151-CVAP-G2 - Rear view



- | | | | |
|---|---------------|---|-----|
| 1 | System status | 2 | VPN |
|---|---------------|---|-----|

Figure 14: C8151-CVAI-G2 and C8151-CVAP-G2 - Front view

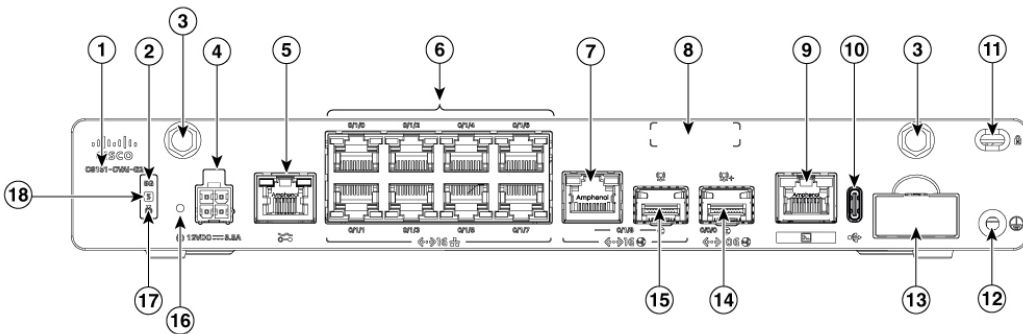

- | | | | |
|----|-------------------------------------|----|-----------------------------|
| 1 | Product Identification Number (PID) | 2 | 5G LED Indicator |
| 3 | Antenna SMA connector | 4 | 4-Pin power connector |
| 5 | RJ11 DSL Port | 6 | GE RJ45 0/1/0 to 0/1/7 |
| 7 | GE 0/1/8 - RJ45 | 8 | Serial number |
| 9 | RJ45 console port | 10 | USB-C 3.0 |
| 11 | Kensington lock slot | 12 | Grounding |
| 13 | Dual nano SIM card slot | 14 | TE 0/0/0 - XGSPON/10GBASE-T |
| 15 | GE 0/1/8 - SFP | 16 | Reset button |

Power supply

Explains the power supply configurations for the routers and provides instructions for installing the router with a PSU on a rack tray, ensuring reliable and safe hardware operation.

The product power specifications are as follows:

- AC input voltage: Universal 100 to 240 VAC
- Frequency: 50 to 60 Hz
- Maximum output power: Up to 30W/66W for non-PoE supply and up to 150W for PoE supply.
- PoE and PoE+ (only for C8161-G2)
- Output voltage: +12V for system power and -53.5V for PoE power.

Table 4: Power requirements for Cisco 8100 Series Secure Routers

Device supported	Power source	Input rated	Output rated
C8130-G2 C8131-G2	30W AC Power Adapter (PWR-CC1-30W)	100-240VAC, 1A	12V, 2.5A
C8130-G2 C8131-G2 C8140-G2 C8151-G2 C8130-VAI-G2 C8130-VAP-G2 C8151-CVAI-G2 C8151-CVAP-G2	66W AC Power Adapter (PWR-CC1-66W)	100-240VAC, 2A	12V, 5.5A
C8161-G2	150W AC Power Adapter (PWR-CC1-150W-AC)	100-240 VAC, 2.5A	12V 6.0A, -53.5V 1.55A

Install the router with a PSU on a rack tray

Use this task to to install the router with a PSU (Power Supply Unit).

This section explains how to install the router with a PSU (Power Supply Unit) on a rack-tray.

1. Obtain the rack-tray.
2. Align the router with the mounting holes on the rack-tray as shown in the figure (after step 6).
3. Secure the router to the tray using the provided screws.
4. Attach the velcro straps to the Power Supply Unit (PSU).
5. Secure the PSU alongside the router using the velcro straps.
6. Connect the PSU to the router using the power cable.

Figure 15: Rack-tray installation with PSU for Cisco 8100 Series Secure Routers

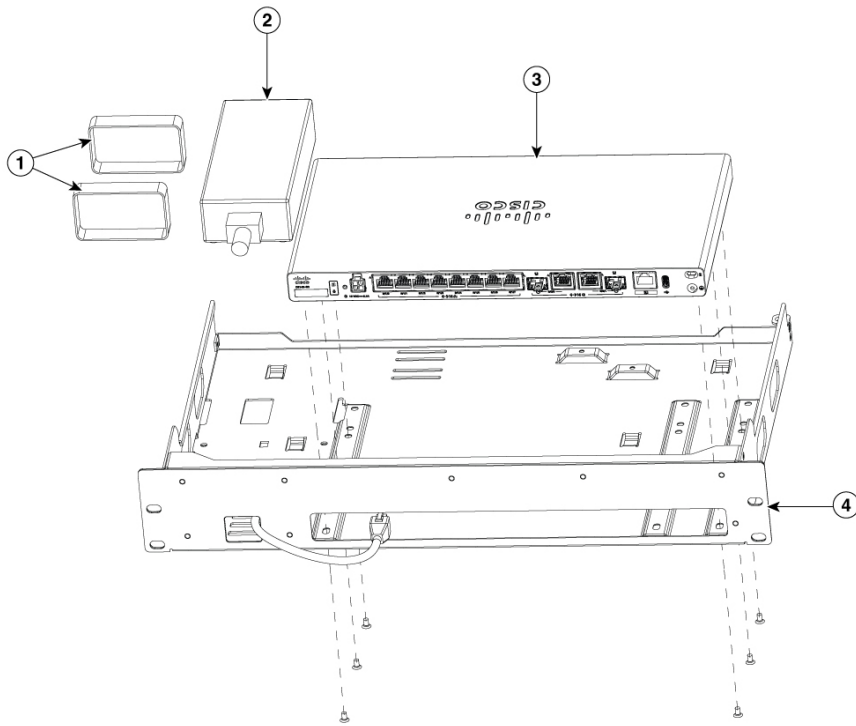

- | | |
|---|---------------|
| 1 | Velcro straps |
| 2 | PSU |
| 3 | Router |
| 4 | Rack-tray |

Figure 16: Rack-tray attached with PSU to Cisco 8100 Series Secure Router

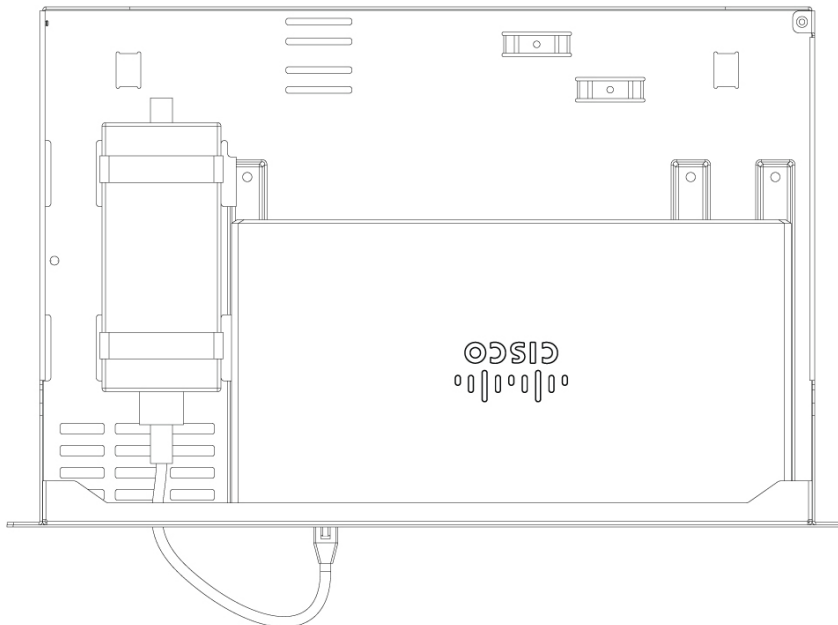

LED indicators

Outlines the meanings and functions of the router's LED indicators, enabling users to monitor status, troubleshoot issues, and verify operational states efficiently.

This table summarizes the LED indicators that are located in the Rear or chassis of the Cisco 8100 Series Secure Routers.

Table 5: LED Indicators for Cisco 8100 Series Secure Routers

Port	LED color	Description
System status (Front and Rear)	Green and Amber	Off—No power. Steady Green - System is operating normally. Blinking Amber – BIOS/ROMmon is booting. Steady Amber – BIOS/ROMmon has completed booting, and the system is at the ROMmon prompt or booting the platform software.
VPN	Green	Off– No tunnel. Steady Green– At least one tunnel is up.
Activity (WAN and LAN ports)	Green	Off– No data transmission. Blinking Green - TXD/RXD data.
Link, non-PoE (WAN and LAN ports)	Green	Off– No link. Steady Green– Link up.
Link, with PoE (WAN and LAN ports, C8161-G2 only)	Green	Off– No link, PoE administratively down. Steady Green– link up; if PoE device, power is enabled.
Power over Ethernet (PoE/PoE+)	Green	Off – No -53.5V PoE power supply connected to router. Steady Green– -53.5V PoE power supply connected and all powered ports operating normally.
Blue beacon	Blue	Off – No attention needed. Blinking Blue– Beacon active.

Table 6: LED Indicators for C8151-CVAI-G2 and C8151-CVAP-G2

Port	Colour and Description
5G LED	Blank - No service Steady Green- 4G Steady Blue- 5G

Reset button

Describes the purpose and operation of the reset button, explaining how to perform reboots and recover system functionality using this hardware feature.

The actuation of the Reset button is only recognized during ROMmon boot, that is, as the router comes to the ROMmon prompt.

The Reset button does not require much force to be pressed. The Reset button should be pressed only with a small implement such as the tip of a pen or a paper clip. When the Reset button is pressed at startup, the system LED turns green.

Slots and interfaces

Details the available interface slots and connectivity options on the routers, guiding users in identifying and utilizing ports for network integration and device expansion.

The Cisco 8100 Series Secure Routers designates its interfaces using a 3-tuple notation that lists the slot, sub-slot, and port in the format slot/sub-slot/port. The slot number is reserved for the motherboard, which is "0". Each interface type is allocated a sub-slot and the port number is a unique port on the interface.

Table 7: Slots and Interfaces

Sub-slot 0/x/x	Interface type
0	Ethernet WAN
1	Ethernet LAN
2	DSL or Cellular
3	Cellular

 **Note**

These interfaces located in Sub-slot 0/1 also functions as WAN Combo ports:

- C8130-VAI-G2, C8130-VAP-G2: Interface Gi0/1/4

Periodic inspection and cleaning

Provides guidelines and best practices for conducting regular inspections and cleaning of Cisco 8100 Series Secure Routers to maintain optimal performance and prolong hardware lifespan.

We recommend that you periodically inspect and clean the external surface of the router. Removing is recommended to minimize the negative impact of environmental dust or debris. The frequency of inspection and cleaning is dependent upon the severity of the environmental conditions, but we recommend cleaning the router once every six months.

 **Note**

Sites with ambient temperatures consistently above 25° C or 77° F and with potentially high levels of dust or debris might require periodic preventative maintenance cleaning.

2 Prepare for Installation

Topics:

- [Prepare for router installation](#)
- [Safety recommendations](#)
- [General site requirements](#)
- [Safety with electricity](#)
- [Network cabling specifications](#)
- [Required tools and equipment for installation and maintenance](#)

Prepare for router installation

Introduces key considerations and preparatory steps required before beginning router installation, ensuring all preliminary requirements and best practices are addressed for a successful deployment.

Before you install the Cisco 8100 Series Secure Routers, you must prepare your site for the installation. This chapter provides the preinstallation steps, such as recommendations and requirements that should be considered before installing your router.

- Ensure that the power and cabling requirements are in place at your installation site.
- Ensure that the equipment required to install the router is available.
- Ensure that your installation site meets the environmental conditions to maintain normal operation.

Before installing the router, you must consider power and cabling requirements that must be in place at your installation site, special equipment for installing the router, and the environmental conditions your installation site must meet to maintain normal operation.

The shipping package for the router is engineered to reduce the chances of product damage associated with routine material handling experienced during shipment.

- Router should always be transported or stored in its shipping package in the upright position.
- Keep the router in the shipping container until you have determined the installation site.

Note

Inspect all items for shipping damage. If an item appears damaged, contact a Cisco customer service representative immediately.

Safety recommendations

Details safety protocols and guidelines to prevent accidents and ensure safe handling during the installation and maintenance of network equipment.

Before you install, configure, or perform maintenance on the router, review the documentation for the procedure you are about to perform, paying special attention to the safety warnings. These guidelines will help to ensure your own safety and protect your Cisco equipment.

- Cisco safety policy mandates that all its routers must conform to the requirements of IEC 62368-1 with appropriate national deviations, as a minimum. In addition, Cisco routers must also meet the requirements of any other normative documents, for example, standards, technical specifications, laws or regulations.
- Never attempt to lift an object that might be too heavy for you to lift by yourself.
- Always unplug the power cable before installing or removing a chassis.
- Keep the chassis area clear and dust free during and after installation.
- Keep tools and chassis components away from walk areas.
- Do not wear loose clothing, jewelry (including rings and chains), or other items that could get caught in the chassis. Fasten your tie or scarf and sleeves.
- The router operates safely when it is used in accordance with its marked electrical ratings and product-usage instructions.

 **Note**

Do not unpack the system until you are ready to install it. Keep the chassis in the shipping container to prevent accidental damage until you determine an installation site. Use the appropriate unpacking documentation included with the system.

 **Warning**
Statement 1071—Warning Definition

IMPORTANT SAFETY INSTRUCTIONS

Before you work on any equipment, be aware of the hazards involved with electrical circuitry and be familiar with standard practices for preventing accidents. Read the installation instructions before using, installing, or connecting the system to the power source. Use the statement number at the beginning of each warning statement to locate its translation in the translated safety warnings for this device.

SAVE THESE INSTRUCTIONS

Read the installation instructions in this document before you connect the system to its power source. Failure to read and follow these guidelines could lead to an unsuccessful installation and possibly damage the system and components.

General site requirements

Explains general site requirements for installation, including site selection guidelines, rack requirements, and power guidelines, enabling users to prepare compliant and optimal installation environments.

Ensure that the site is properly prepared before beginning installation. If you are experiencing shutdowns or unusually high errors with your existing equipment, the guidelines provided in this section can also help you isolate the cause of failures and prevent future problems.

The general safety warnings are as follows:

 **Note****Statement 407**—Japanese Safety Instruction

You are strongly advised to read the safety instruction before using the product.

<https://www.cisco.com/web/JP/techdoc/pldoc/pldoc.html>

When installing the product, use the provided or designated connection cables/power cables/AC adapters.

〈製品使用における安全上の注意〉

www.cisco.com/web/JP/techdoc/index.html

接続ケーブル、電源コードセット、ACアダプタ、バッテリーなどの部品は、必ず添付品または指定品をご使用ください。添付品・指定品以外をご使用になると故障や動作不良、火災の原因となります。また、電源コードセットは弊社が指定する製品以外の電気機器には使用できないためご注意ください。

 **Warning****Statement 445**—Connect the Chassis to Earth Ground

To reduce the risk of electric shock, connect the chassis of this equipment to permanent earth ground during normal use.

 **Warning****Statement 1005**—Circuit Breaker

This product relies on the building's installation for short-circuit (overcurrent) protection. To reduce risk of electric shock or fire, ensure that the protective device is rated not greater than:

 **Warning**

Statement 1015—Battery Handling

To reduce risk of fire, explosion, or leakage of flammable liquid or gas:

- Replace the battery only with the same or equivalent type recommended by the manufacturer.
- Do not dismantle, crush, puncture, use a sharp tool to remove, short the external contacts, or dispose of the battery in fire.
- Do not use if battery is warped or swollen.
- Do not store or use battery in a temperature $> .$
- Do not store or use battery in low air pressure environment $< .$

 **Warning**

Statement 1022—Disconnect Device

To reduce the risk of electric shock and fire, a readily accessible disconnect device must be incorporated in the fixed wiring.

 **Warning**

Statement 1024—Ground Conductor

This equipment must be grounded. To reduce the risk of electric shock, never defeat the ground conductor or operate the equipment in the absence of a suitably installed ground conductor. Contact the appropriate electrical inspection authority or an electrician if you are uncertain that suitable grounding is available.

 **Warning**

Statement 1028—More Than One Power Supply

This unit might have more than one power supply connection. To reduce risk of electric shock, remove all connections to de-energize the unit.

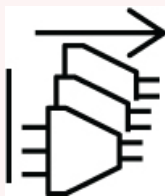

 **Warning****Statement 1029—Blank Faceplates and Cover Panels**

Blank faceplates and cover panels serve three important functions: they reduce the risk of electric shock and fire, they contain electromagnetic interference (EMI) that might disrupt other equipment, and they direct the flow of cooling air through the chassis. Do not operate the system unless all cards, faceplates, front covers, and rear covers are in place.

 **Warning****Statement 1032—Lifting the Chassis**

To prevent personal injury or damage to the chassis, never attempt to lift or tilt the chassis using the handles on modules, such as power supplies, fans, or cards. These types of handles are not designed to support the weight of the unit.

 **Warning****Statement 1046—Installing or Replacing the Unit**

To reduce risk of electric shock, when installing or replacing the unit, the ground connection must always be made first and disconnected last.

If your unit has modules, secure them with the provided screws.

 **Warning****Statement 1055—Class 1/1M Laser**

Invisible laser radiation is present. Do not expose to users of telescopic optics. This applies to Class 1/1M laser products.



 **Warning****Statement 1071**—Warning Definition

IMPORTANT SAFETY INSTRUCTIONS

Before you work on any equipment, be aware of the hazards involved with electrical circuitry and be familiar with standard practices for preventing accidents. Read the installation instructions before using, installing, or connecting the system to the power source. Use the statement number at the beginning of each warning statement to locate its translation in the translated safety warnings for this device.

SAVE THESE INSTRUCTIONS

 **Warning****Statement 1073**—No User-Serviceable Parts

There are no serviceable parts inside. To avoid risk of electric shock, do not open.

 **Warning****Statement 1074**—Comply with Local and National Electrical Codes

To reduce risk of electric shock or fire, installation of the equipment must comply with local and national electrical codes.

 **Warning****Statement 1098**—Lifting Requirement

people are required to lift the heavy parts of the product. To prevent injury, keep your back straight and lift with your legs, not your back.

 **Warning****Statement 9001**—Product Disposal

Ultimate disposal of this product should be handled according to all national laws and regulations.

Site selection guidelines

Explains the environmental and compliance factors required for placing Cisco 8100 Series Secure Routers.

The Cisco 8100 Series Secure Routers require specific environmental operating conditions. Temperature, humidity, altitude, and vibration can affect the performance and reliability of the router. Operating temperature is defined as the local ambient temperature and is not monitored by IOS. The operating temperature range can be found on the product's [data sheet](#). The next section provide specific information to help you plan for the proper operating environment.

The Cisco 8100 Series Secure Routers are designed to meet the industry EMC, safety, and environmental standards described in the Regulatory Compliance and Safety Information for the Cisco 8100 Series Secure Routers document.

Rack requirements

Explains the key requirements for equipment racks used with Cisco 8100 Series Secure Routers.

For the Cisco 8100 Series Secure Routers, use brackets with a 19-inch rack.

This information can help you plan your equipment rack configuration:

- Allow clearance around the rack for maintenance.
- Allow at least one rack unit of vertical space between routers; more clearance is required when stacking multiple Cisco 8100 Series Secure Routers. Provide adequate heat removal mechanism to keep the surrounding air temperature well within the specified operating temperature condition.
- Ensure that the rack is level and stable before extending a component from the rack.
- Ensure that proper airflow is provided to the components in the rack.

Note

More spacing may be required depending on the installation environment.

- Enclosed racks must have adequate ventilation. Ensure that the rack is not congested because each router generates heat. An enclosed rack should have louvered sides and a fan to provide cooling air. The heat generated by the equipment near the bottom of the rack can be drawn upward into the intake ports of the equipment above it.
- When mounting a chassis in an open rack, ensure that the rack frame does not block the intake or exhaust ports. If the chassis is installed on slides, check the position of the chassis when it is seated in the rack.

Power guidelines and requirements

Explains the essential power requirements and site considerations for Cisco 8100 Series Secure Routers.

Check the power at your site to ensure that you are receiving power that is free of spikes and noise. Install a power conditioner, if necessary.

Refer to the [Power supply](#) section that lists the power requirements for the Cisco 8100 Series Secure Routers.

Safety with electricity

Outlines best practices for electrical safety during installation, including procedures to prevent electrostatic discharge damage and protect equipment and personnel.

Follow these basic guidelines when you are working with any electrical equipment:

- Before beginning any procedures requiring access to the chassis interior, locate the emergency power-off switch for the room in which you are working.

- Disconnect all power and external cables before installing or removing a chassis.
- Do not work alone when potentially hazardous conditions exist.
- Never assume that power has been disconnected from a circuit; always check.
- Do not perform any action that creates a potential hazard to people or makes the equipment unsafe. Never install equipment that appears damaged.
- Carefully examine your work area for possible hazards such as moist floors, ungrounded power extension cables, and missing safety grounds.

Prevent electrostatic discharge damage

Outlines best practices and cautionary measures you should follow to prevent electrostatic discharge (ESD) damage when handling circuit cards and modules.

Electrostatic discharge (ESD) can damage equipment and impair electrical circuitry. It can occur if electronic printed circuit cards are improperly handled and can cause complete or intermittent failures. Always follow ESD prevention procedures when removing and replacing modules:

- Ensure that the router chassis is electrically connected to ground.
- Wear an ESD-preventive wrist strap, ensuring that it makes good skin contact. Connect the clip to an unpainted surface of the chassis frame to channel unwanted ESD voltages safely to ground. To guard against ESD damage and shocks, the wrist strap and cord must operate effectively.
- If no wrist strap is available, ground yourself by touching a metal part of the chassis

Caution

For the safety of your equipment, periodically check the resistance value of the anti-static strap. It should be between 1 and 10 megohms (Mohm).

Network cabling specifications

Describes network cabling specifications for installation, detailing console port considerations, EIA/TIA-232 connections, and Ethernet connections to ensure reliable and standards-compliant network connectivity.

The next sections describe the cables, and the specifications required to install Cisco 8100 Series Secure Routers.

Console port considerations

Explains the key considerations and cabling requirements for using console ports to access a router.

The router includes a RJ45 console port. The console ports provide access to the router using a console terminal connected to the console port. This section discusses important cabling information to consider before connecting the router to a console terminal or modem.

Console terminals send data at speeds slower than modems do; therefore, the console port is ideally suited for use with console terminals.

EIA/TIA-232

Depending on the cable and the adapter used, this port appears as a DTE or DCE device at the end of the cable. Only one port can be used at the same time. The default parameters for the console port are 9600 baud, 8 data bits, 1 stop bit, and no parity.

The console port does not support hardware flow control. For detailed information about installing a console terminal, see the Connecting to a Console Terminal or Modem section.

For cable and port pinouts, see the Cisco Modular Access Router Cable Specifications document located on Cisco.com.

Ethernet connections

Explains the types and specifications of Ethernet connections supported by Cisco routers.

The IEEE has established Ethernet as standard IEEE 802.3. This table shows the key specifications for Ethernet connections supported by Cisco routers.

Table 8: Ethernet Transmission Standards and Distance Specifications

Ethernet Standard & Specifications	Maximum Distance
1000BASE-T—1000 Mb/s full duplex transmission over a Category 5 or better unshielded twisted-pair (UTP) cable.	Supports the Ethernet maximum length of 328 feet (100 meters).
100BASE-T—100 Mb/s full duplex transmission over a Category 5 or better unshielded twisted-pair (UTP) cable.	Supports the Ethernet maximum length of 328 feet (100 meters).
10BASE-T—10 Mb/s full duplex transmission over a Category 5 or better unshielded twisted-pair (UTP) cable.	Supports the Ethernet maximum length of 328 feet (100 meters).

Refer the [Cisco Modular Access Router Cable Specifications](#) document for information about Ethernet cables, connectors, and pinouts.

Required tools and equipment for installation and maintenance

Lists the required tools and equipment essential for performing installation and maintenance tasks efficiently and safely.

The tools and equipments required to install and upgrade the router and its components are as follows:

- An ESD-preventive cord and a wrist strap.
- A number 2 Phillips screwdriver.
- Phillips screwdrivers: small, 3/16-in. (4 to 5 mm) and medium 1/4-in. (6 to 7 mm). You might need these when you install or remove modules.
- Screws that fit the rack.
- A wire crimper.
- A wire for connecting the chassis to an earth ground: AWG 14 (2 mm²) or larger wire.
- An appropriate user-supplied UL or a CSA-certified ring terminal with an inner diameter of 1/4 in. (5 to 7 mm).

3 Install 8100 Series Secure Routers

Topics:

- [Install and connect](#)
- [Install the router](#)
- [Connect the power cable](#)

Install and connect

Introduces the initial installation process by describing hardware unpacking steps and identifying all items included with your router to ensure readiness for subsequent installation tasks.

This chapter describes how to install and connect Cisco 8100 Series Secure Routers to LAN and WAN networks.

Unpack the router

This chapter describes how to install and connect Cisco 8100 Series Secure Routers to LAN and WAN networks. Unpack the router only when you are ready to install it. If the installation site is not ready, to prevent accidental damage, keep the chassis in its shipping container until you are ready to install. The router, accessory kit, publications, and any optional equipment you order may be shipped in more than one container. When you unpack the containers, check the packing list to ensure that you have received all the listed items.

Items shipped with your router

Unpack the box and verify that all items listed on the invoice were shipped with the Cisco 8100 Series Secure Routers.

These items are shipped with your router:

- Getting Started/Product Document of Compliance
- Grounding Lug Kit
- Power Supply
- AC Power Cord

Install the router

Details mounting and installation procedures for desktop, rack, under-desk, shelf, and wall setups, including guidance on bracket attachment, chassis grounding, safety warnings for ground and optical connections, and required installation tasks.

After unpacking, based on your requirements, you can set up the Cisco 8100 Series Secure Router under-desk, on a desktop, a rack, or the wall.

 **Note**

You can install external modules before or after mounting a router. However, if you choose to install the external modules after mounting the router on the rack or wall, ensure that you have optimal access to the back/front panel of the router.

 **Note**

To prevent the system from overheating, do not operate the device in an area that exceeds a local ambient of 40° C. For altitudes above sea-level, de-rate the ambient operating temperature by 1° C per 1000-feet of elevation.

 **Note**

When mounting a Cisco 8100 Series Secure Router, the local ambient should be measured 2-inches below the fully mounted product when possible. When this is not possible the local ambient should be measured 2-inches from the I/O side of the product.

 **Note**

The product's surface temperature may be elevated at higher throughputs; however, the product is operating as expected.

Module	Mounting Options
C8130-G2	Desktop , Rack mount , Under Desk/Shelf Mount , Wall mount using Key-hole slots , Wall mount DIN-rail brackets
C8131-G2	
C8140-G2	
C8151-G2	
C8161-G2	
C8130-CVAI-G2	
C8130-VAP-G2	
C8151-CVAI-G2	
C8151-CVAP-G2	

Desktop

Configure the Cisco 8100 Series Secure Router by mounting it under-desk, on a desktop, a rack, or the wall, based on your requirements.

If you choose to setup the router on a desktop, you can place the router on a desktop, bench top, or shelf.

Caution

Do not place anything on top of the device and do not stack devices on a desktop, else, this causes the product to overheat.

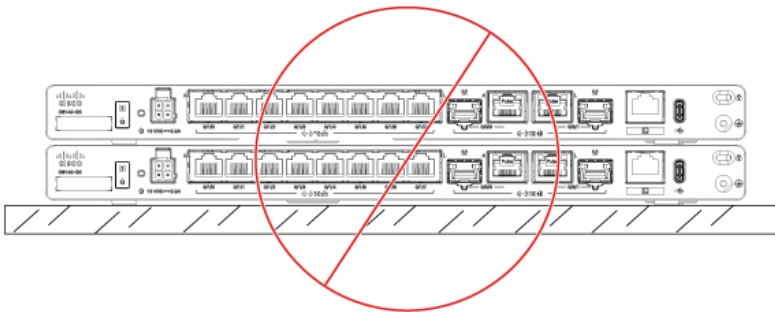

Rack mount

Explains the purpose, installation requirements, and environmental considerations for rack mounting brackets on Cisco 8100 Series Secure Routers.

Secure rack mounting brackets on the chassis before you set up the chassis on the rack.

Caution

Do not stack multiple Cisco 8100 Series Secure Routers when mounting the routers on a tabletop.

Do not put any object on the sides or on top of the routers ensuring that there is ample space for air circulation and heat removal. Your chassis installation must allow unrestricted airflow for chassis cooling.

Important

Periodic Inspection and Cleaning:

We recommend that you periodically inspect and clean the external surface of the router. Removing is recommended to minimize the negative impact of environmental dust, debris, and liquid contamination. The frequency of inspection and cleaning is dependent upon the severity of the environmental conditions, but we recommend cleaning the router once every six months.

 **Note**

Sites with ambient temperatures consistently above 25° C or 77° F and with potentially high levels of dust or debris might require periodic preventative maintenance cleaning.

 **Note**

When mounting Cisco 8100 Series Secure Routers on a rack, ensure at least one rack unit (1RU) of vertical space between routers. This ensures more heat removal, which in turn helps the surrounding air temperature to stay within the specified operating conditions.

Figure 17: Rack-tray assembly

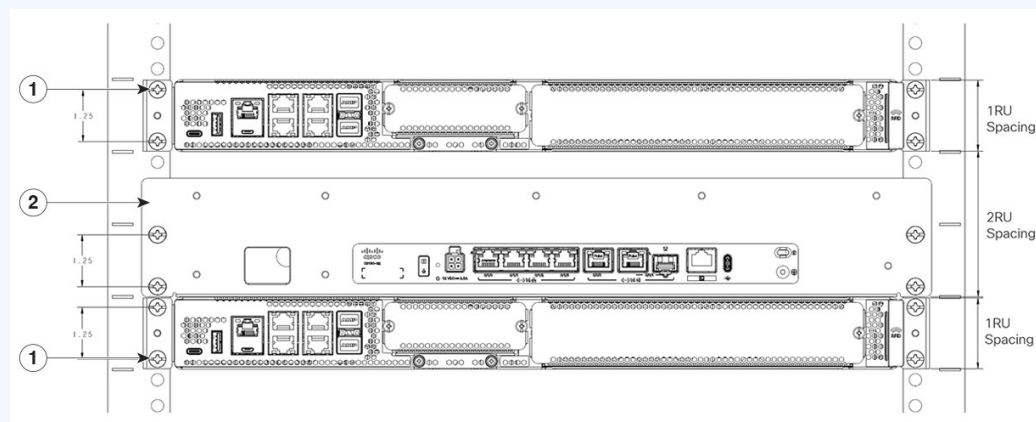

- | | |
|---|--------------------------------------|
| 1 | Typical 1RU Product (reference only) |
| 2 | Rack-tray installed |

Attach the rack mount brackets

This procedure describes how to attach the brackets on the router chassis:

1. Remove the screws from the bottom of the chassis as per shown in these figures.

Figure 18: Removing screws from C8130-G2 and C8131-G2

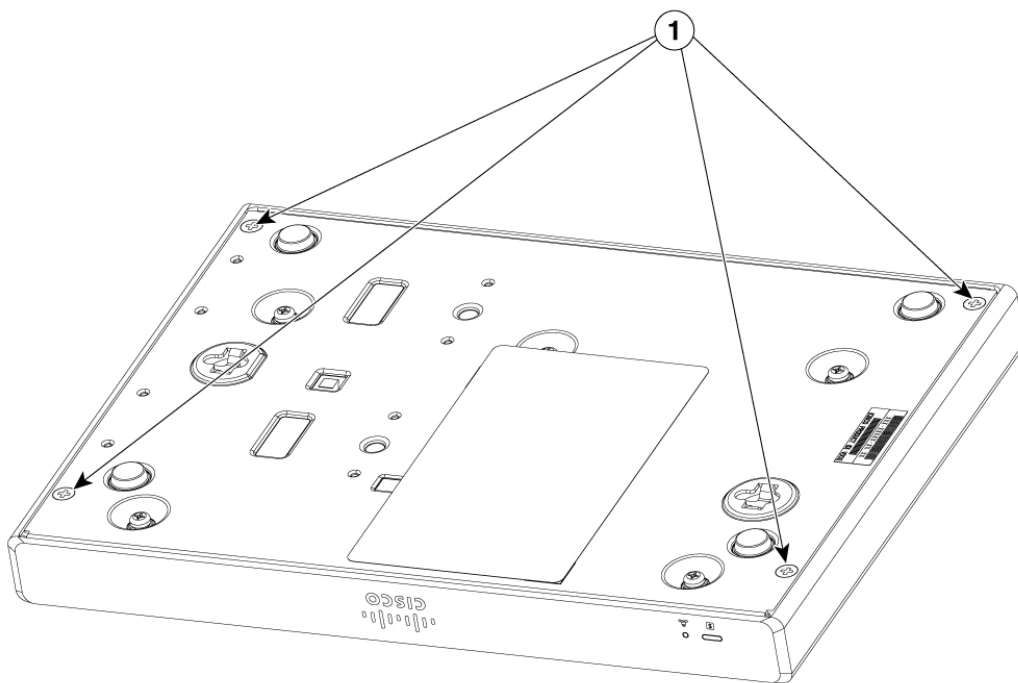

1

Screws

Figure 19: Removing screws from C8140-G2

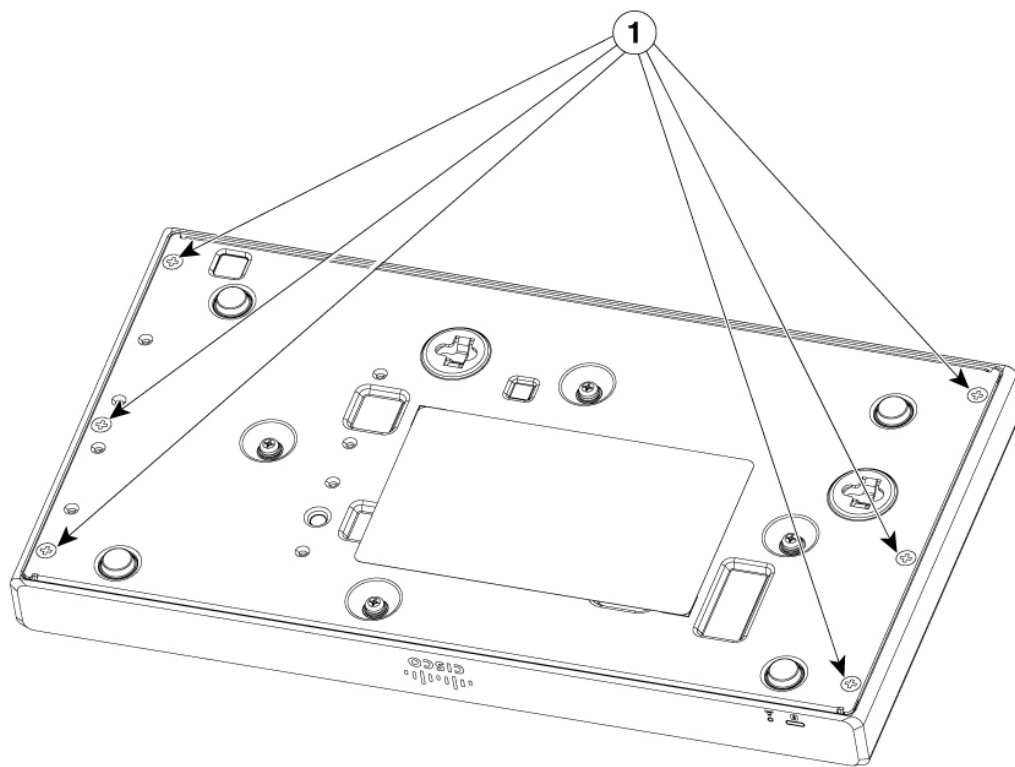

1

Screws

Figure 20: Removing screws from C8151-G2 and C8161-G2

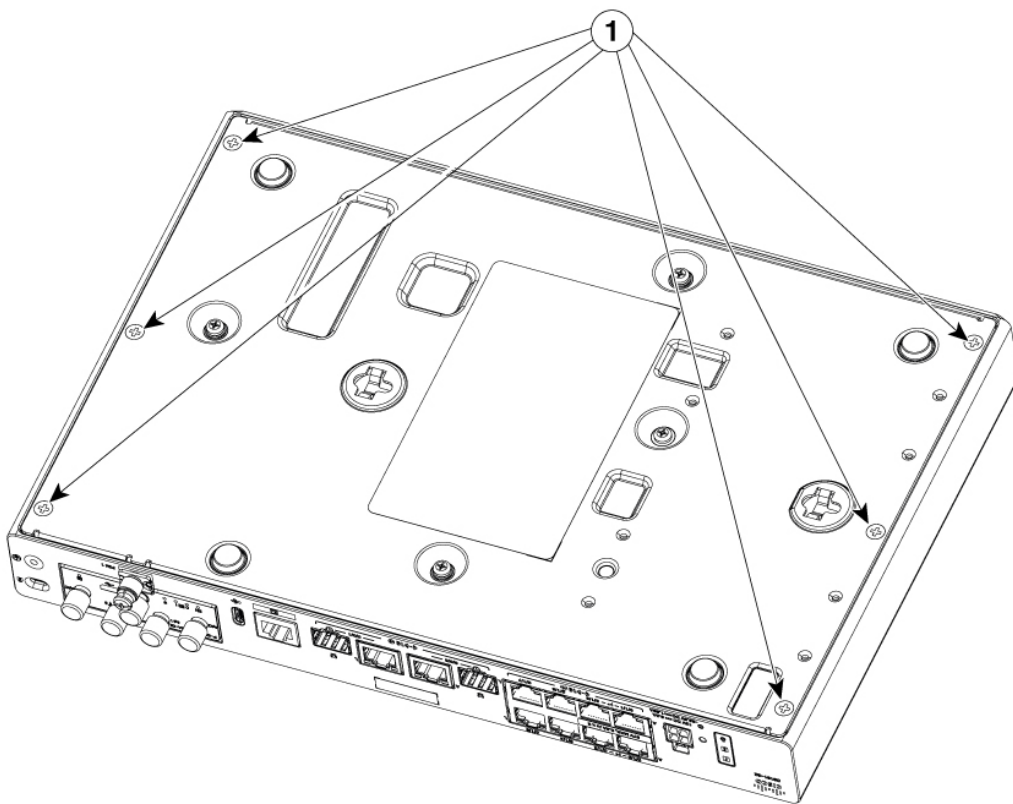

1

Screws

Figure 21: Removing screws from C8130-VAI-G2 and C8130-VAP-G2

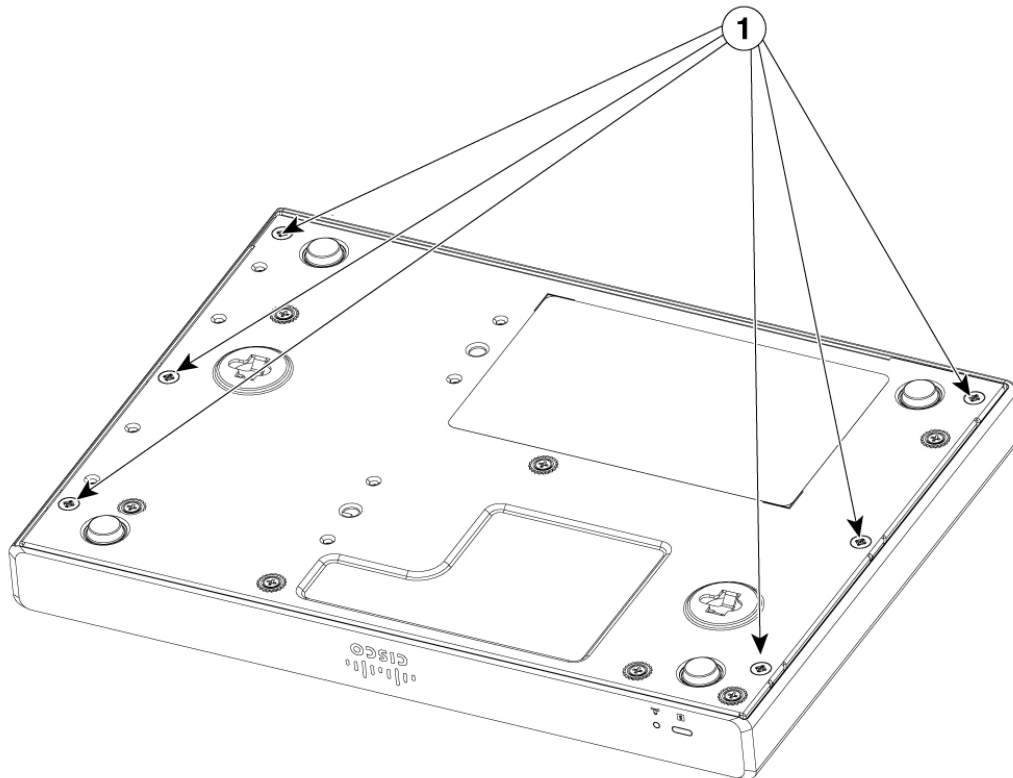

1 Screws

Figure 22: Removing screws from C8151-CVAI-G2 and C8151-CVAP-G2

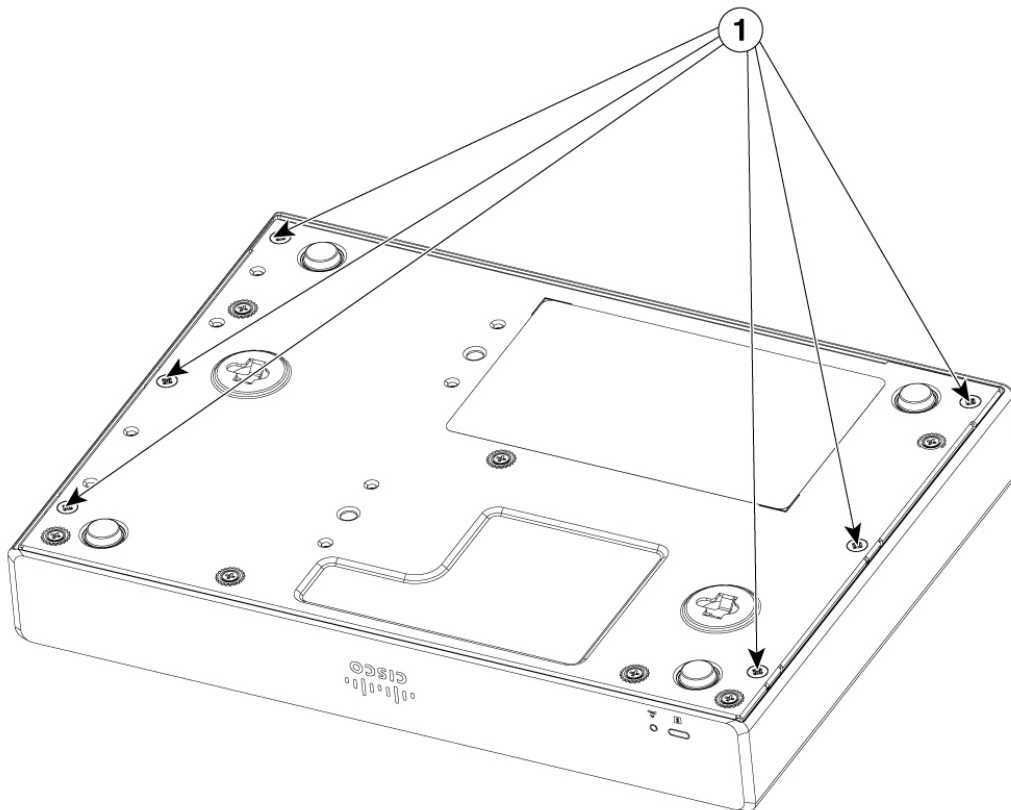

1 Screws

2. Align the bracket to the indicated holes of the chassis.
3. Secure the bracket to the router using the screws that were removed.

Figure 23: Rack mounting bracket installation for C8130-G2 and C8131-G2

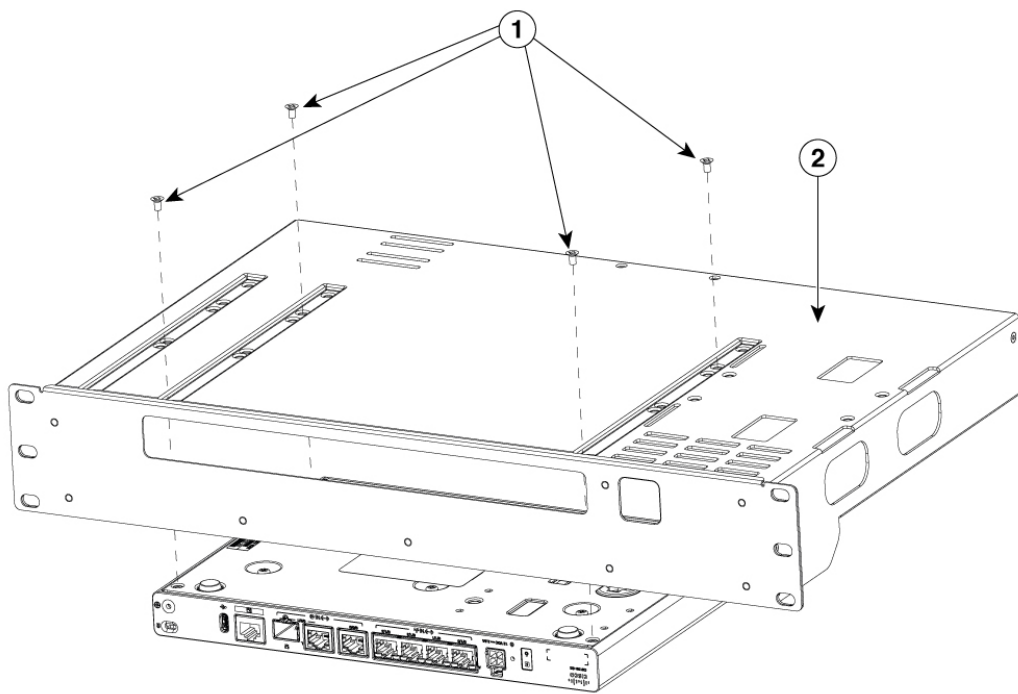

- 1 Screws
- 2 Brackets

Figure 24: Rack mounting bracket installation for C8140-G2

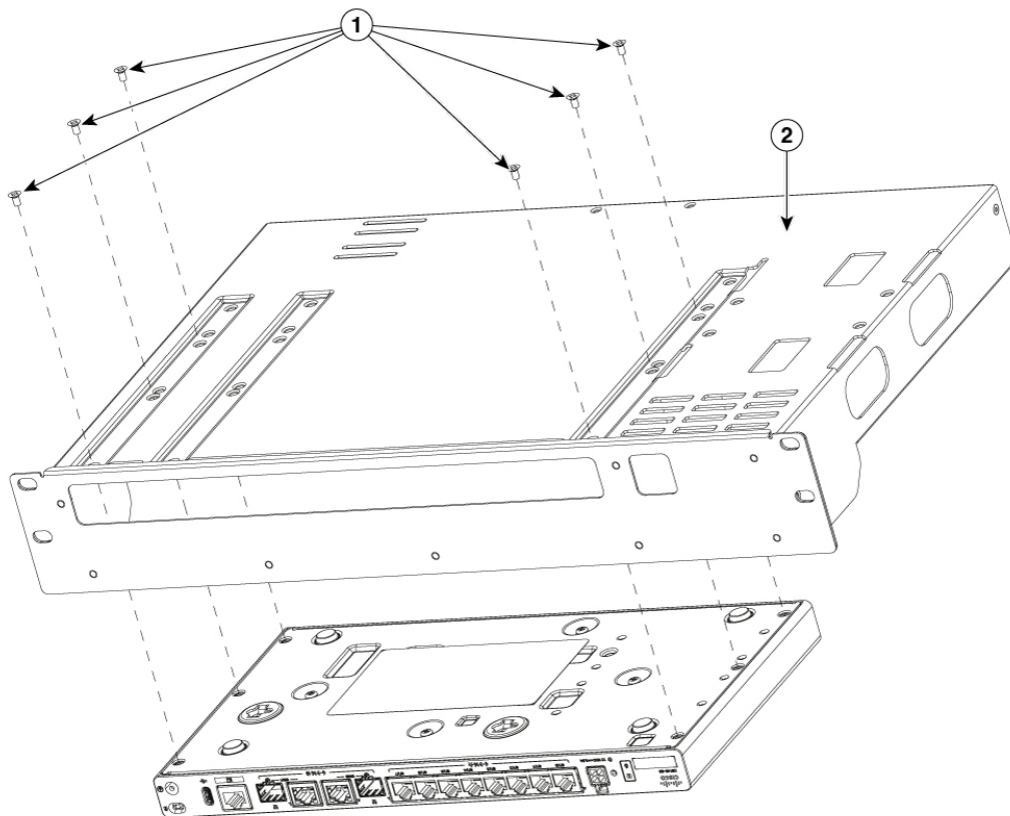

- 1 Screws
- 2 Brackets

Figure 25: Rack mounting bracket installation for C8151-G2 and C8161-G2

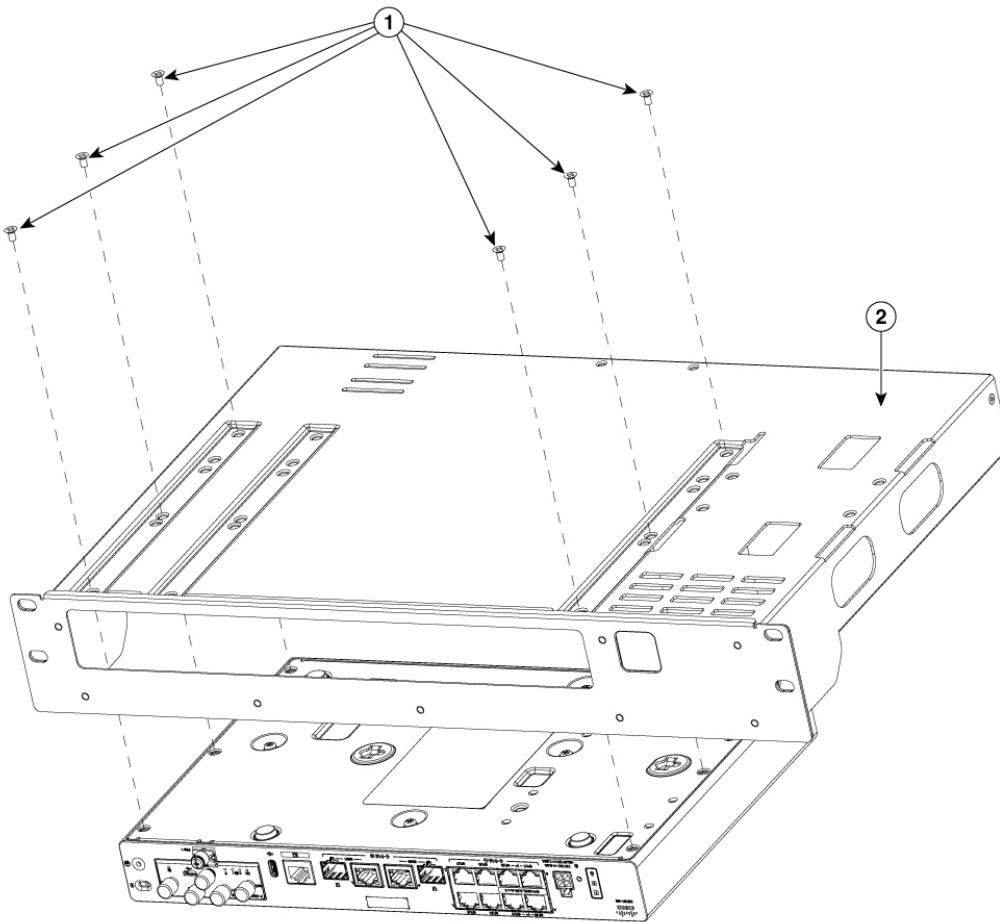

- 1 Screws
- 2 Brackets

Figure 26: Rack mounting bracket installation for C8130-VAI-G2 and C8130-VAP-G2

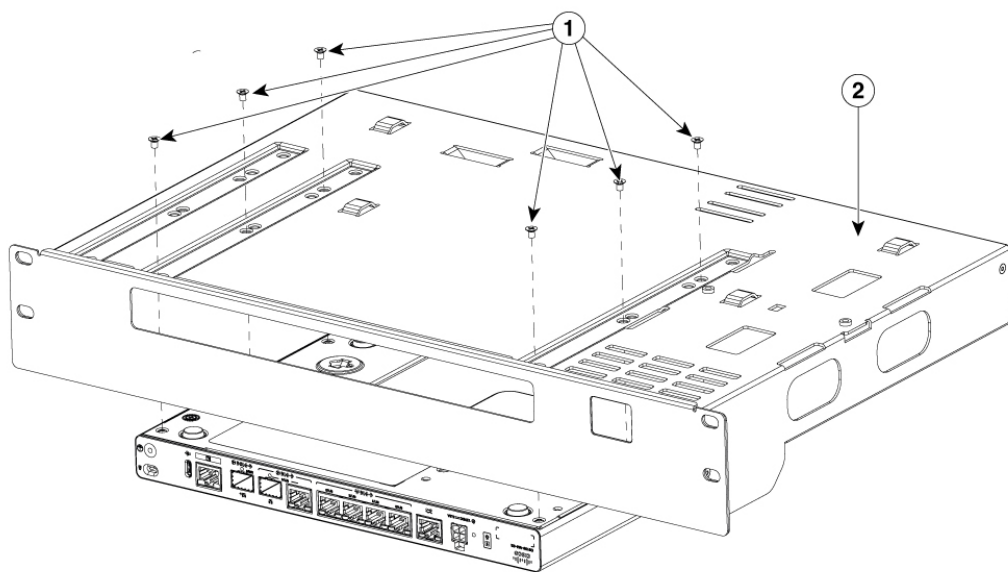

- 1 Screws
- 2 Brackets

Figure 27: Rack mounting bracket installation for C8151-CVAI-G2 and C8151-CVAP-G2

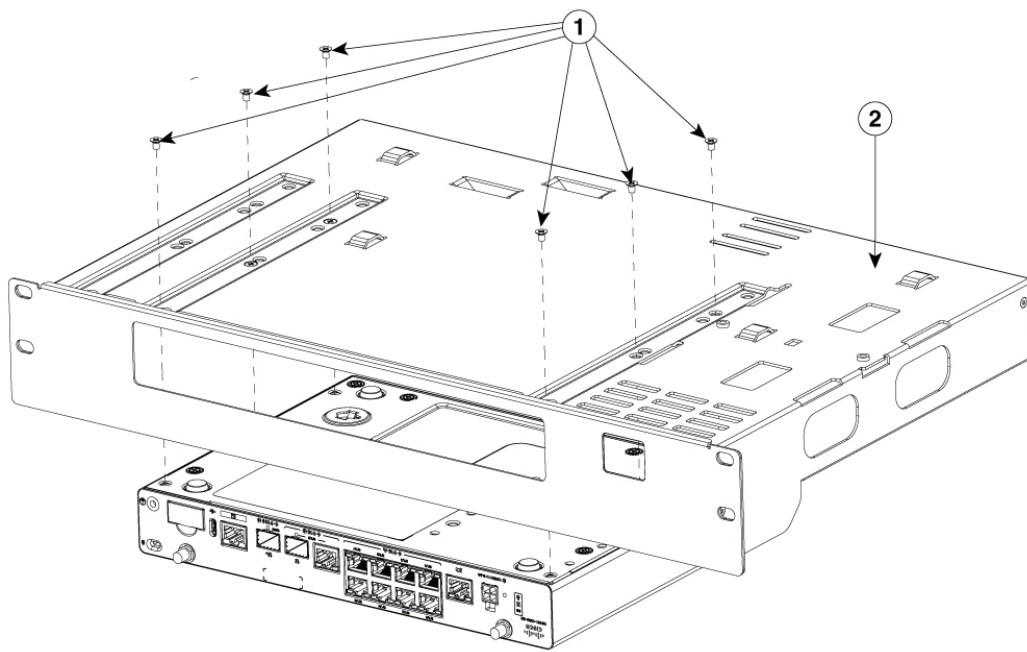

- 1 Screws
- 2 Brackets

Mount the router

Before mounting the router on to the rack, refer to these safety warning statements:

Warning

Statement 1006—Chassis Warning for Rack-Mounting and Servicing

To prevent bodily injury when mounting or servicing this unit in a rack, you must take special precautions to ensure that the system remains stable. The following guidelines are provided to ensure your safety:

- This unit should be mounted at the bottom of the rack if it is the only unit in the rack.
- When mounting this unit in a partially filled rack, load the rack from the bottom to the top with the heaviest component at the bottom of the rack.
- If the rack is provided with stabilizing devices, install the stabilizers before mounting or servicing the unit in the rack.

To install the router, use the screws provided with the accessory kit to secure the router when you mount it over the rack.

Under desk or shelf mount

Explains the characteristics, functions, and usage considerations of screws as fastening hardware.

Installing the router under a desk requires an optional bracket kit that is not included with the router. The kit contains the under-desk brackets and screws to secure the brackets to the bottom of the desk. You can order these kits from your Cisco representative. This procedure describes how to mount a router under a desk or a shelf.

1. Remove the screws from the bottom of the chassis.

Figure 28: Removing screws from C8130-G2 and C8131-G2

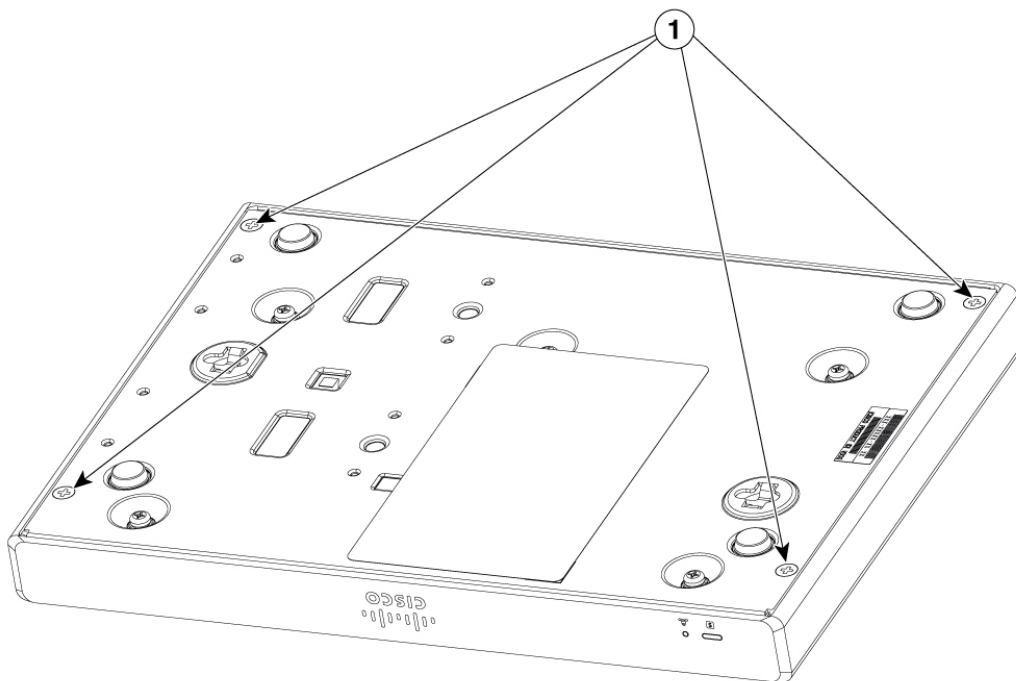

1

Screws

Figure 29: Removing screws from C8140-G2

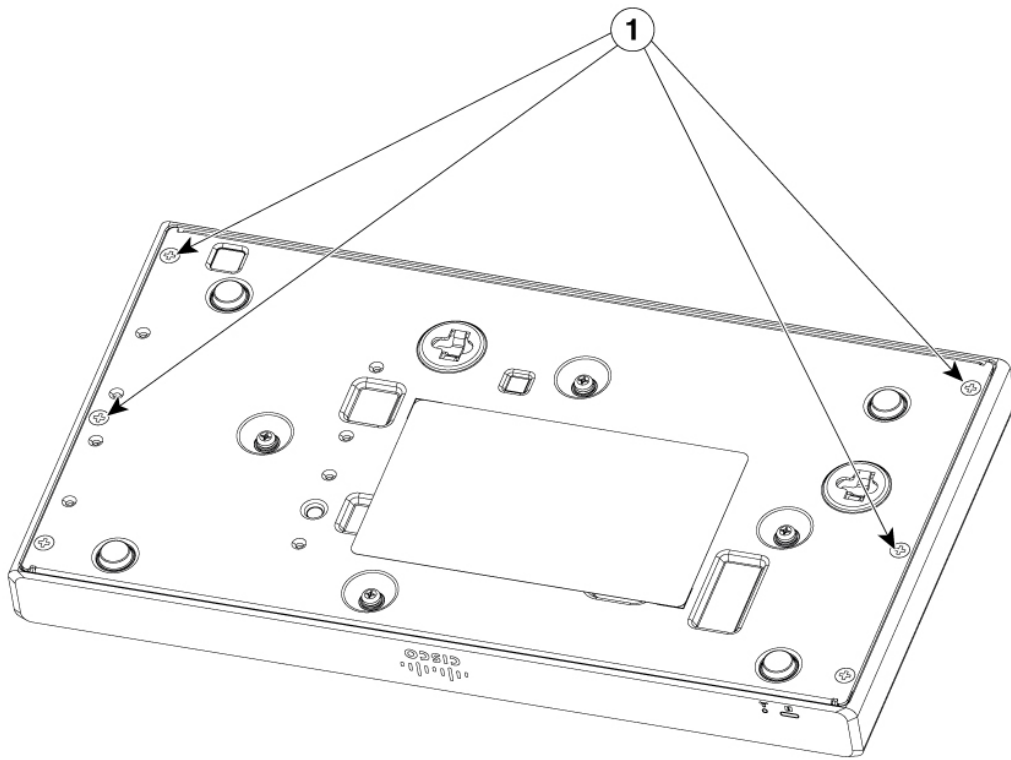

1

Screws

Figure 30: Removing screws from C8151-G2 and C8161-G2

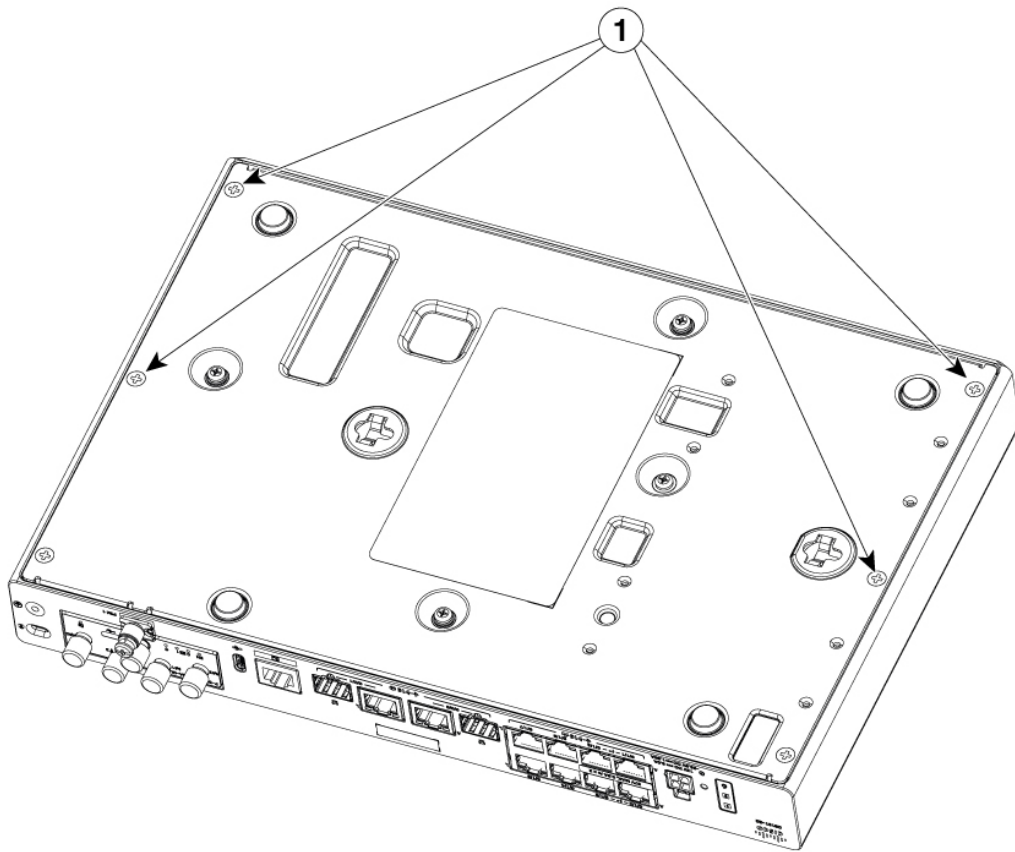

1

Screws

Figure 31: Removing screws from C8130-VAI-G2 and C8130-VAP-G2

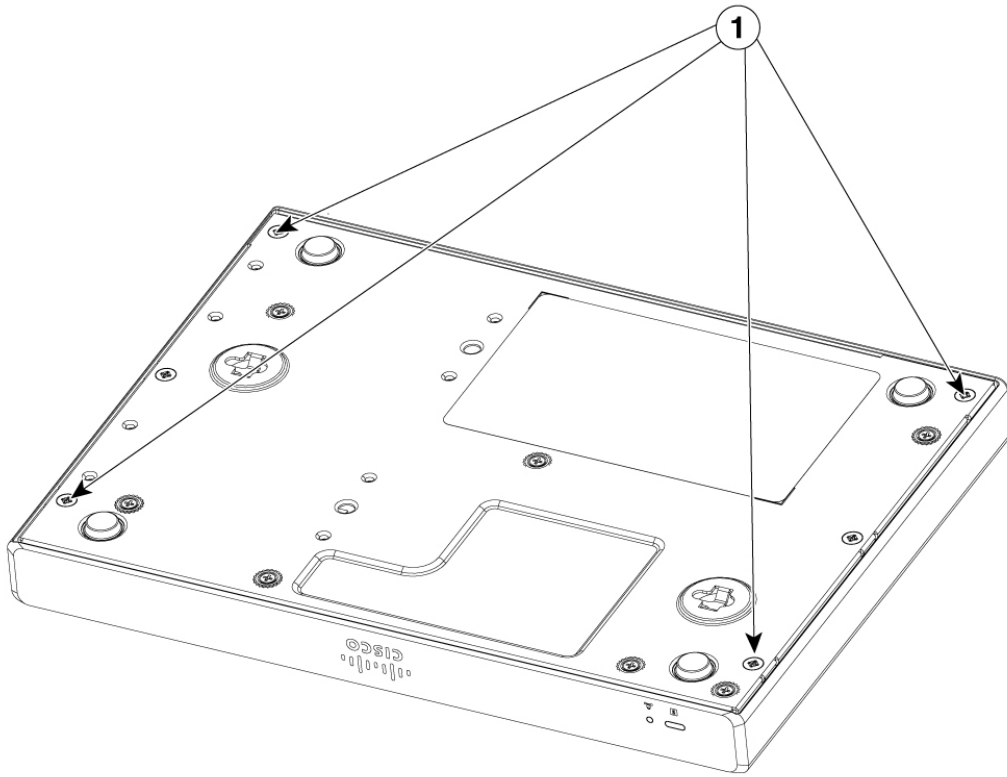

1

Screws

Figure 32: Removing screws from C8151-CVAI-G2 and C8151-CVAP-G2

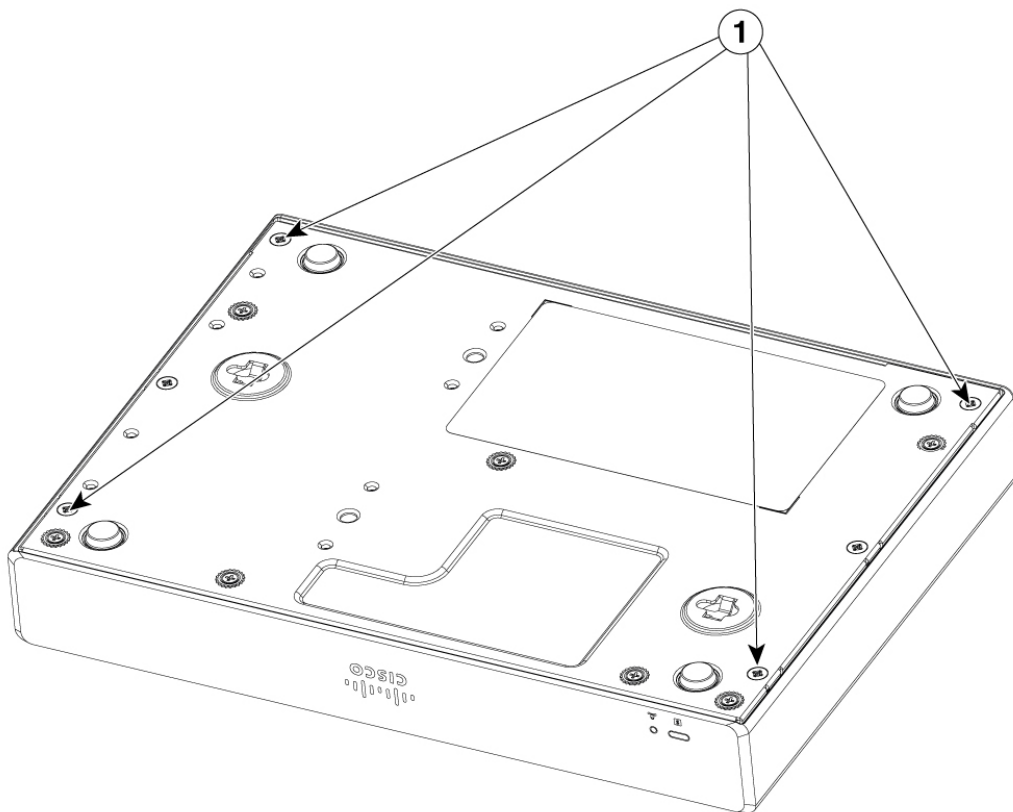

1 Screws

2. Align the brackets to the indicated screw holes of the chassis.

Figure 33: Under desk mounting brackets installation for C8130-G2 and C8131-G2

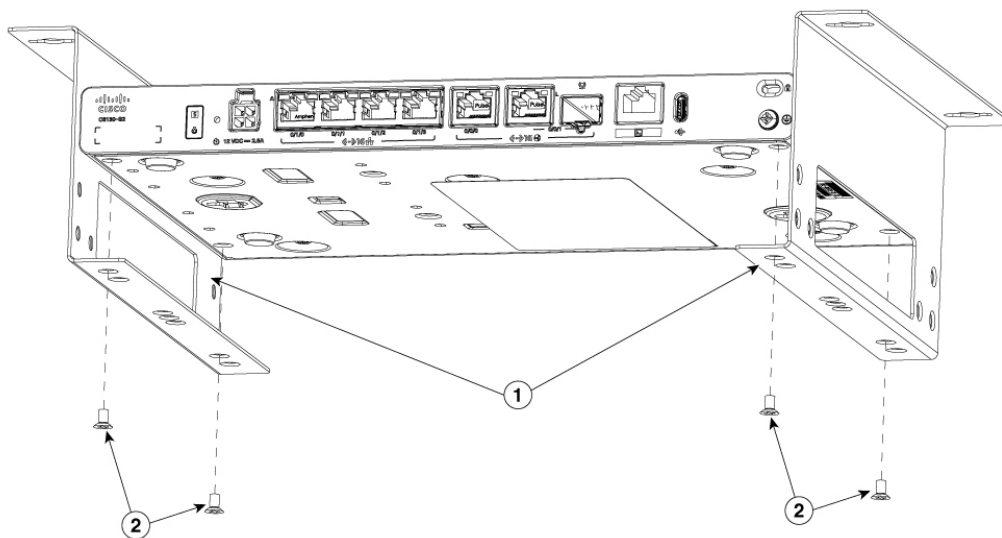

1 Under desk mounting brackets

2

Screws

Figure 34: Under desk mounting brackets installation for C8140-G2

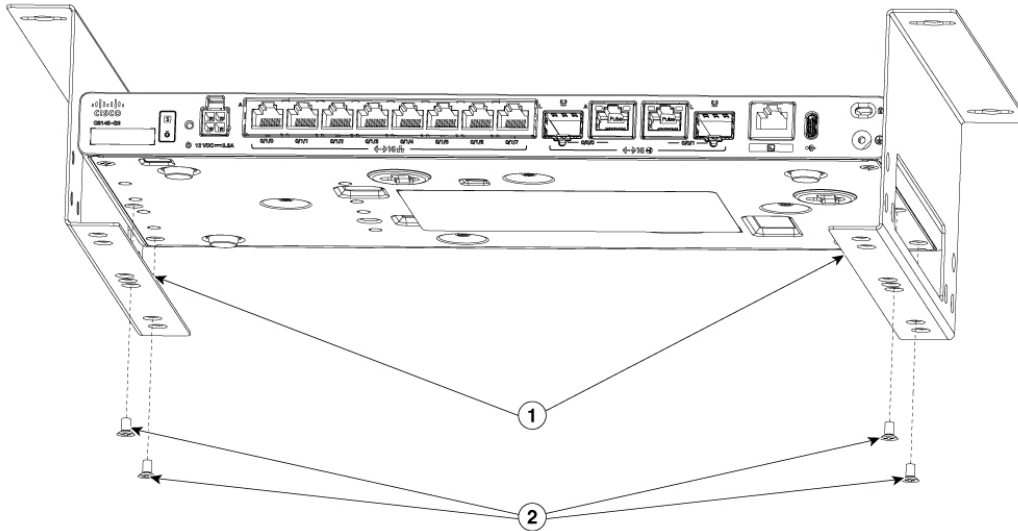

1

Under desk mounting brackets

2

Screws

Figure 35: Under desk mounting brackets installation for C8151-G2 and C8161-G2

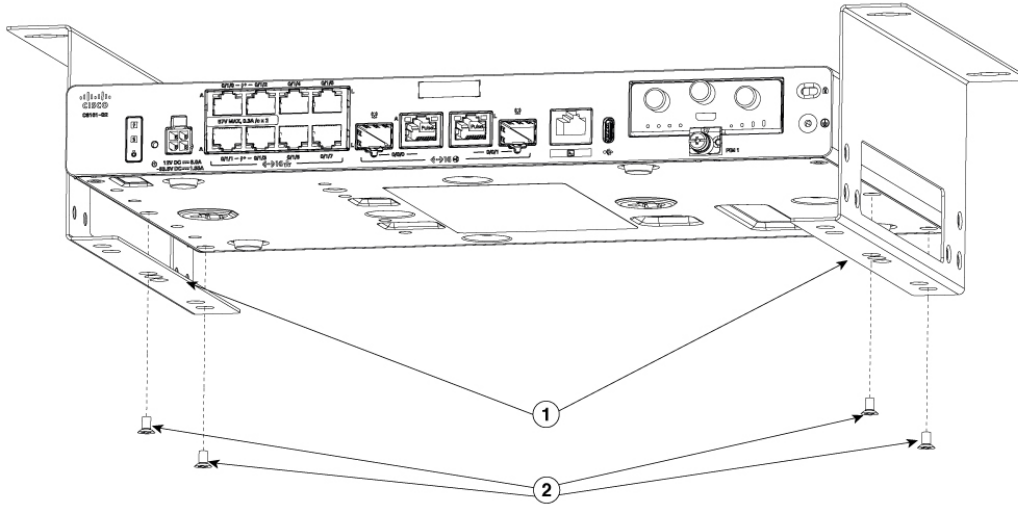

1

Under desk mounting brackets

2

Screws

Figure 36: Under desk mounting brackets installation for C8130-VAI-G2 and C8130-VAP-G2

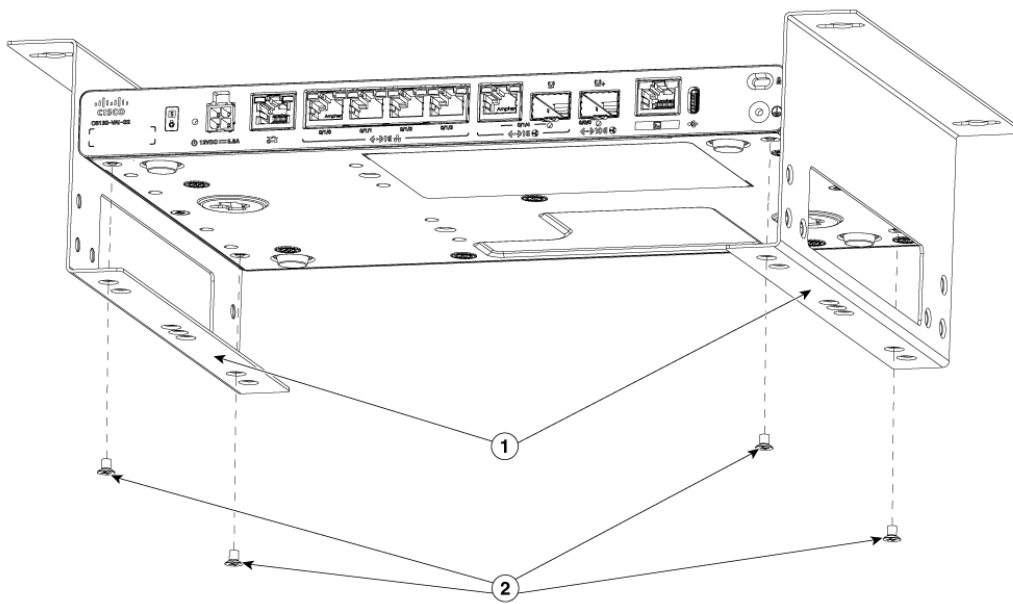

- 1 Under desk mounting brackets
- 2 Screws

Figure 37: Under desk mounting brackets installation for C8151-CVAI-G2 and C8151-CVAP-G2

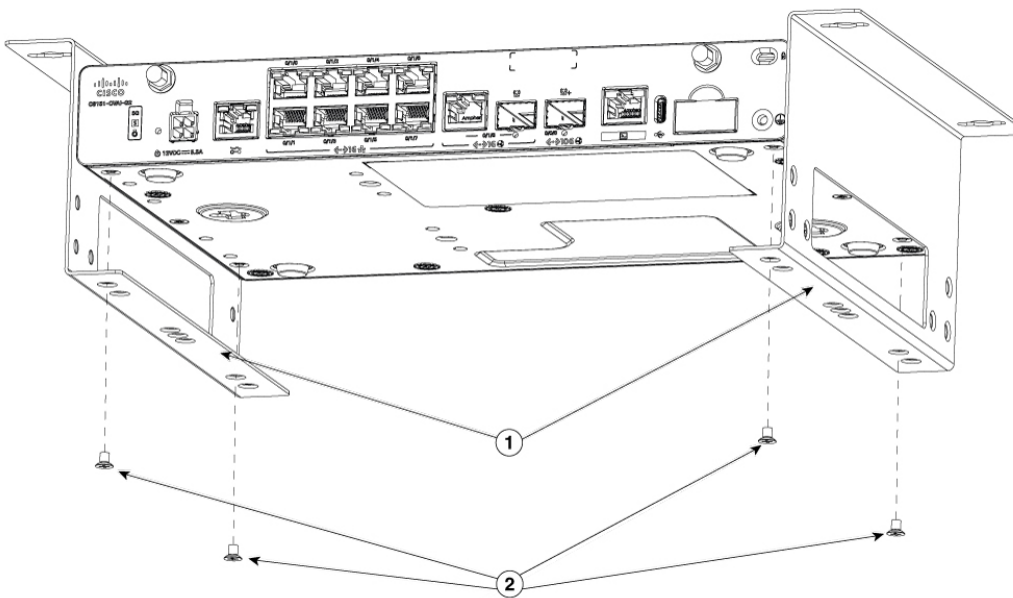

- 1 Under desk mounting brackets
- 2 Screws

3. Secure the under desk mounting brackets to the router using the screws. Ensure that all the screw fasteners on the installed components are securely tightened.

Figure 38: C8130-G2 and C8131-G2 with attached under desk mounting brackets

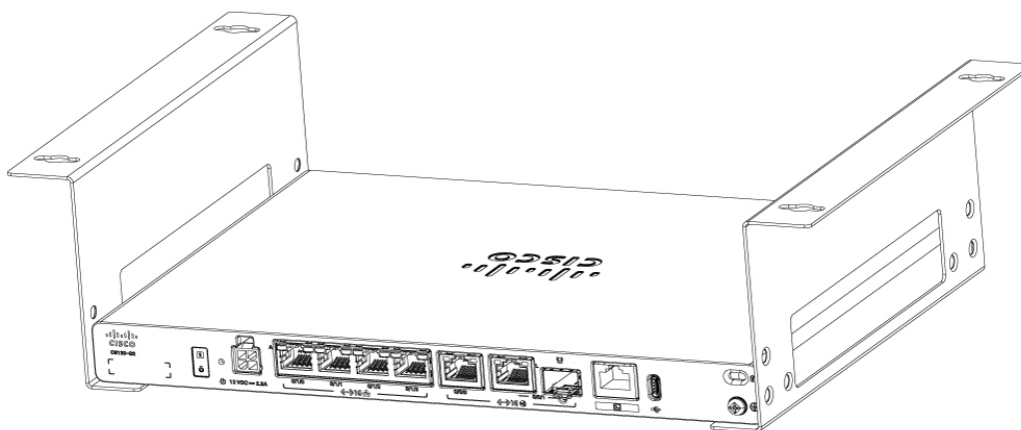

Figure 39: C8140-G2 with attached under desk mounting brackets

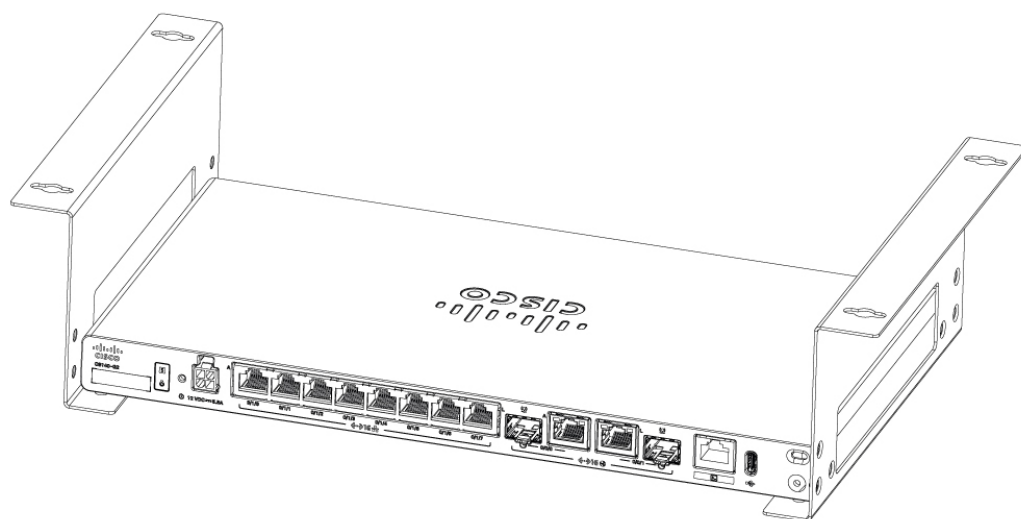

Figure 40: C8151-G2 and C8161-G2 with attached under desk mounting brackets

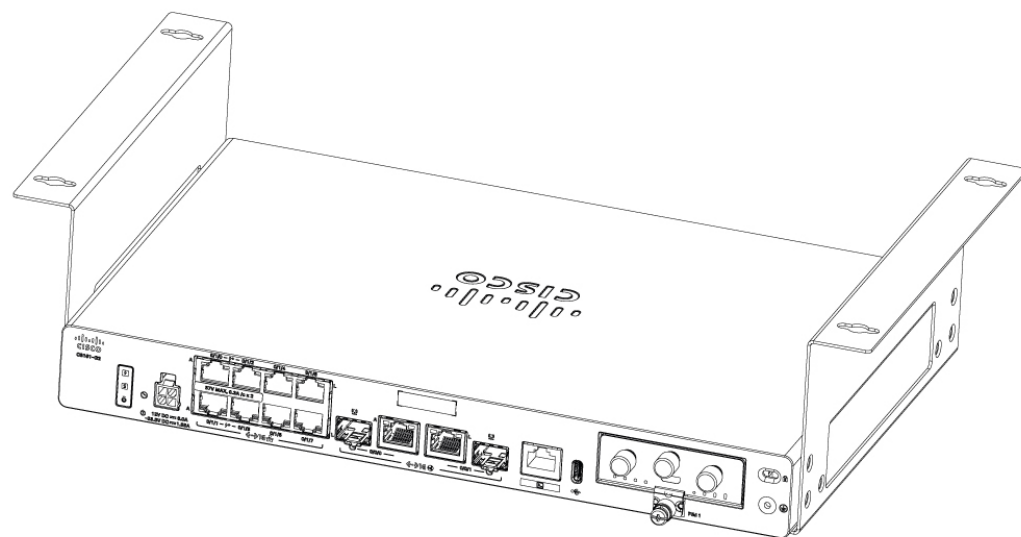

Figure 41: C8130-VAI-G2 and C8130-VAP-G2 with attached under desk mounting brackets

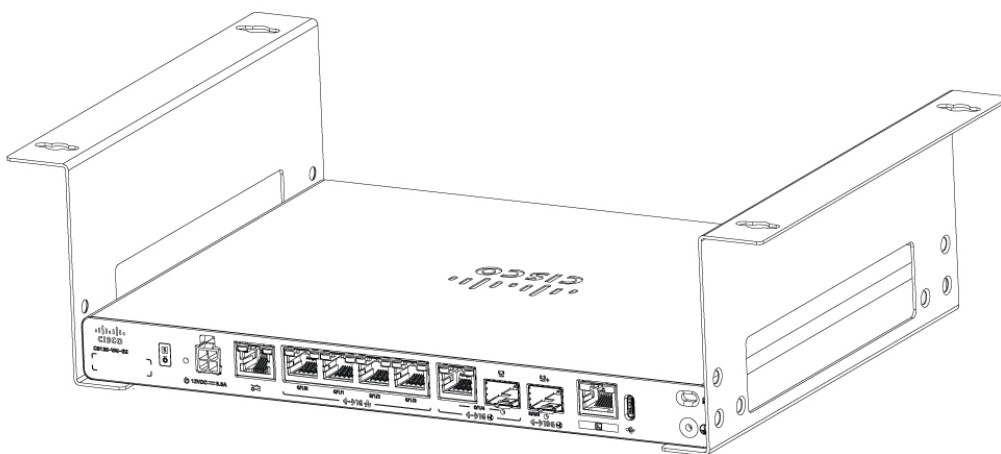
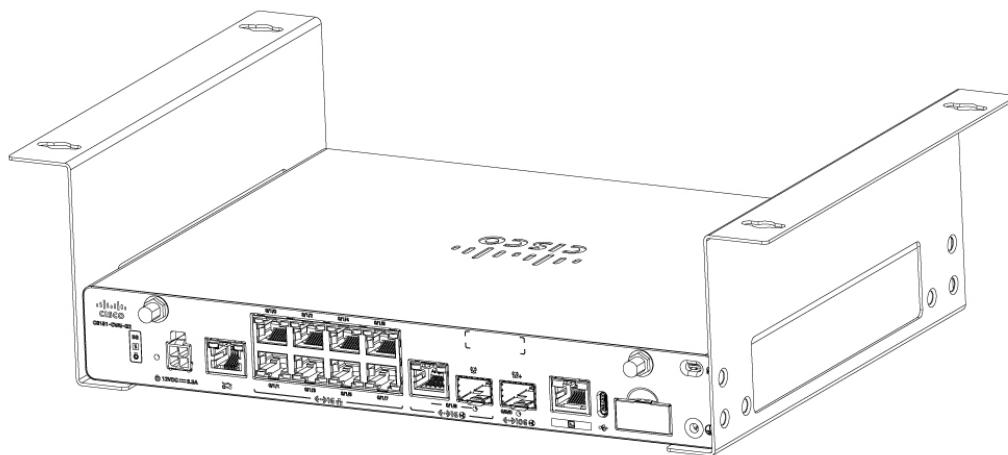

Figure 42: C8151-CVAI-G2 and C8151-CVAP-G2 with attached under desk mounting brackets



4. After the bracket is attached, drill a 2mm hole under the desk and insert the wooden screws. Mount the router under the desk or shelf using the pan-head wood screws.

Figure 43: Mounting C8130-G2 and C8131-G2 under a shelf

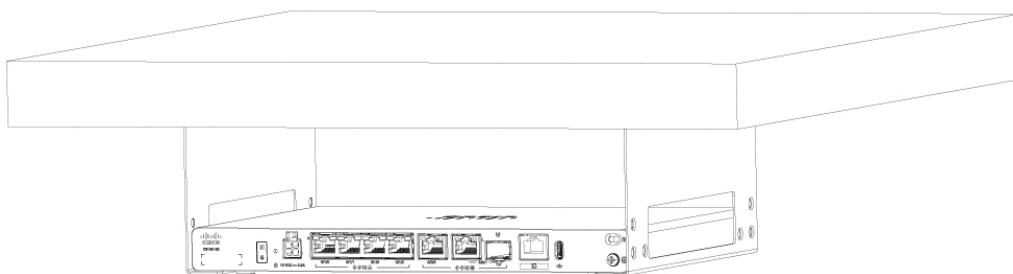

Figure 44: Mounting C8140-G2 under a shelf



Wall mount

Explains the primary methods for mounting a router to a wall and outlines the required clearance for each.

There are two ways to mount a router on the wall, using **Keyhole slots** and **DIN rail brackets**.

Warning

Statement 1094—Read Wall-Mounting Instructions Before Installation

Read the wall-mounting instructions carefully before beginning installation. Failure to use the correct hardware or to follow the correct procedures could result in a hazardous situation to people and damage to the system.

Note

The recommended clearance when a router is horizontally mounted is 1.5 inches on both sides for clearance and 1.75 inches on top. I/O side clearance is needed as it is required to access the cable connections. Clearance is not required on the backside (opposite side from I/O face) unless mounting on a DIN rail. Clearance is required to attach and mount the DIN rail bracket.

Wall mount using Keyhole Slots

The Cisco 8100 Series Secure Routers have keyhole slots at the bottom of the chassis for mounting on a wall or any vertical surface.

Note

When choosing a location for wall mounting the router, consider cable limitations and wall structure.

Note

Route the cables so that they do not put a strain on the connectors or mounting hardware.

1. Measure the distance between both the keyhole slots and mark them onto the wall.
2. Drill holes into the wall as per the markings you took in **Step 1**, and insert the screws in it.

To attach a router to the wall stud, each bracket should have one number 10 wood screw (pan-head) with number 10 washers, or two number 10 washer-head screws. The screws must be long enough to penetrate at least 1.5 inches (38.1 mm) into the supporting wood or metal wall stud.

For hollow-wall mounting, each bracket requires two wall anchors with washers. Wall anchors and washers must be size number 6 (pan-head).

- Place the router onto the screws and slide the router to lock it into place.

Figure 49: Wall mount using keyhole slots for C8130-G2 and C8131-G2

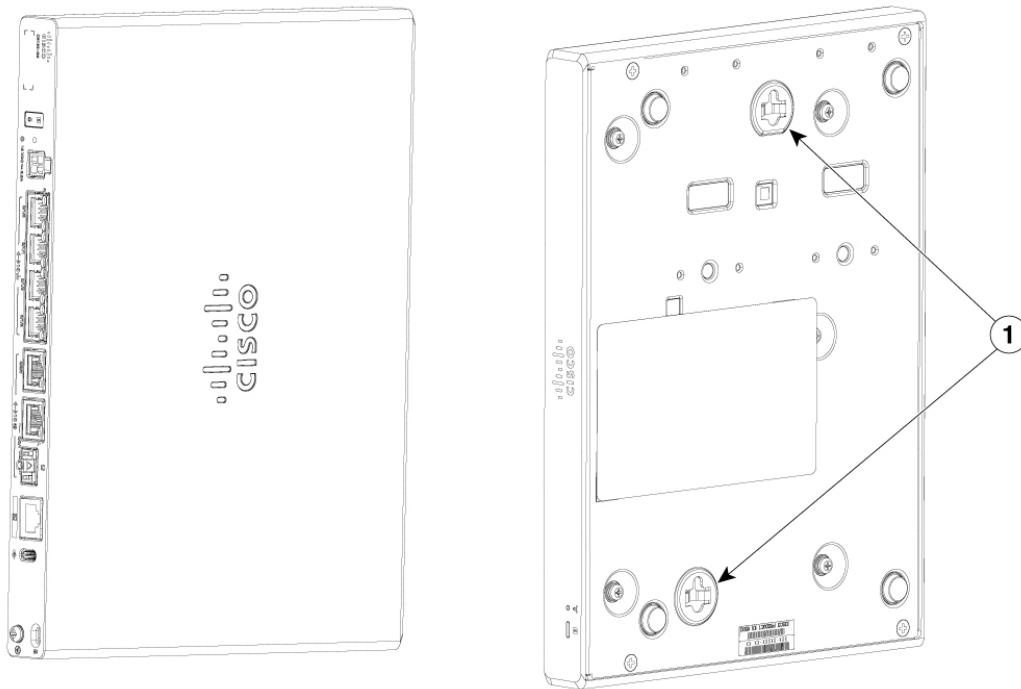

1

Keyhole slots

Horizontal spacing: 1.693 in(43.00 mm)

Vertical spacing: 8.113 in(206.07 mm)

Figure 50: Wall mount using keyhole slots for C8140-G2

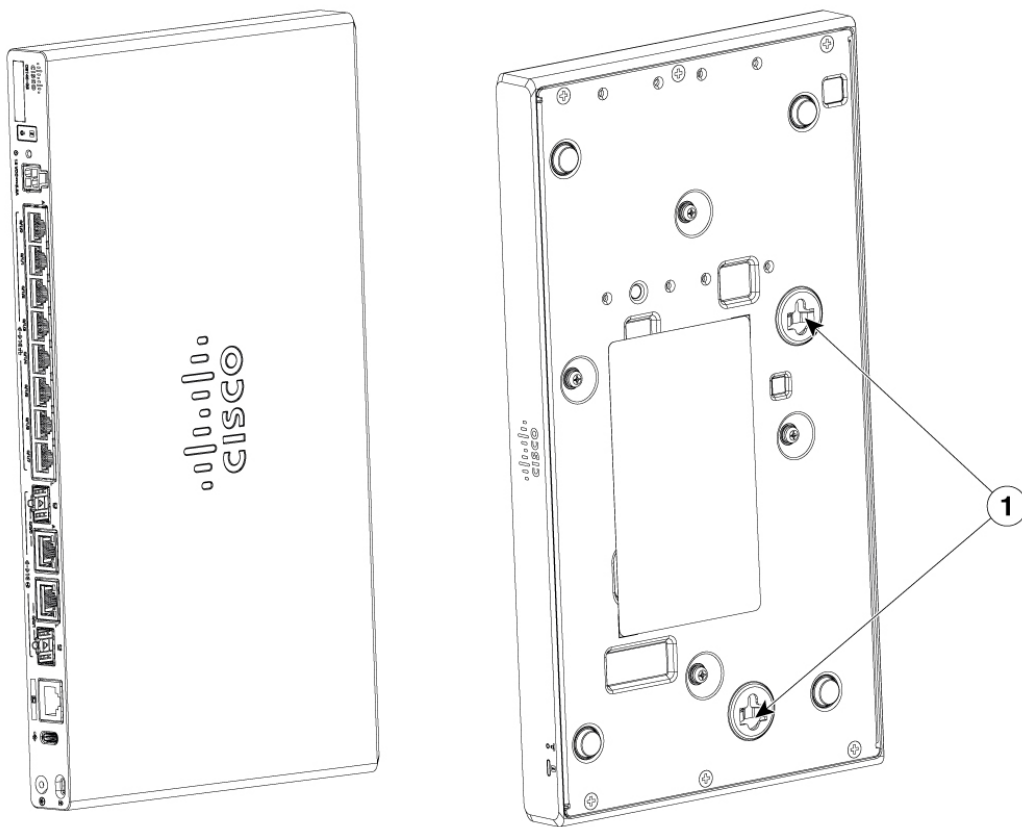

1

Keyhole slots

Horizontal spacing: 1.330 in(33.78 mm)

Vertical spacing: 6.500 in(165.10 mm)

Figure 51: Wall mount using keyhole slots for C8151-G2 and C8161-G2

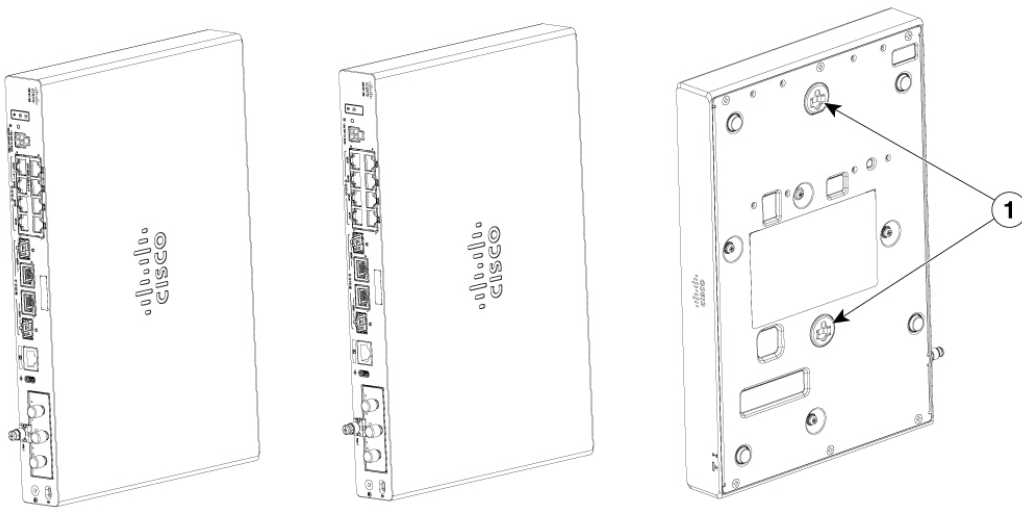

1

Keyhole slots

Key-hole slots spacing: 7.250 in(184.15 mm)

Figure 52: Wall mount using keyhole slots for C8130-VAI-G2 and C8130-VAP-G2

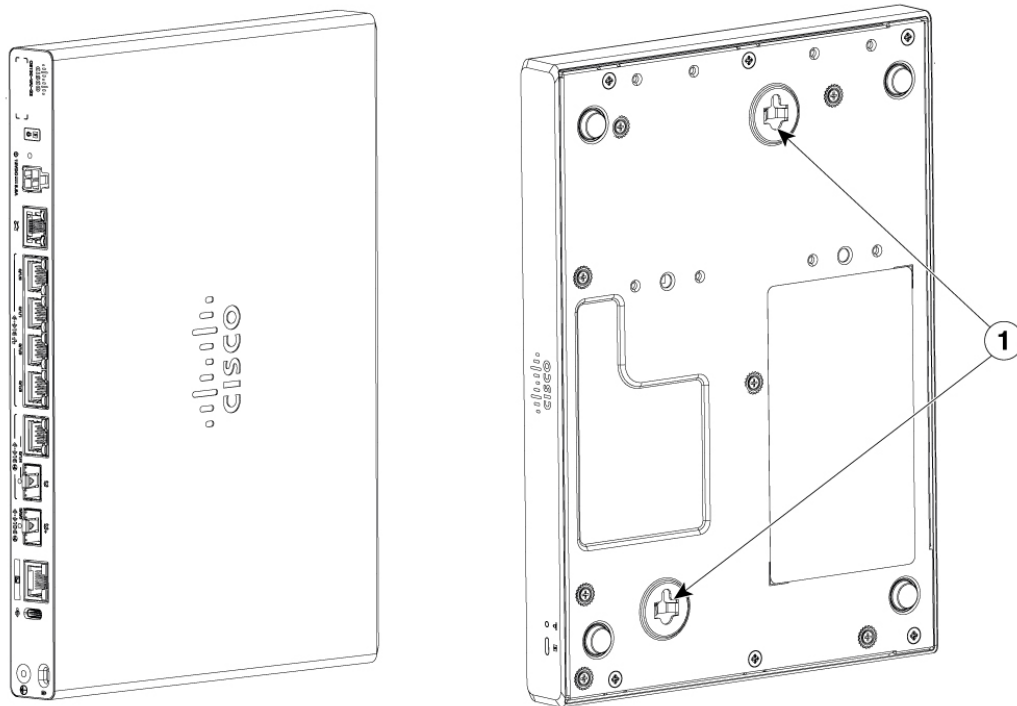

1

Keyhole slots

Horizontal spacing: 2.38 in(60.37 mm)

Vertical spacing: 8.035 in(204.08 mm)

Figure 53: Wall mount using keyhole slots for C8151-CVAI-G2 and C8151-CVAP-G2

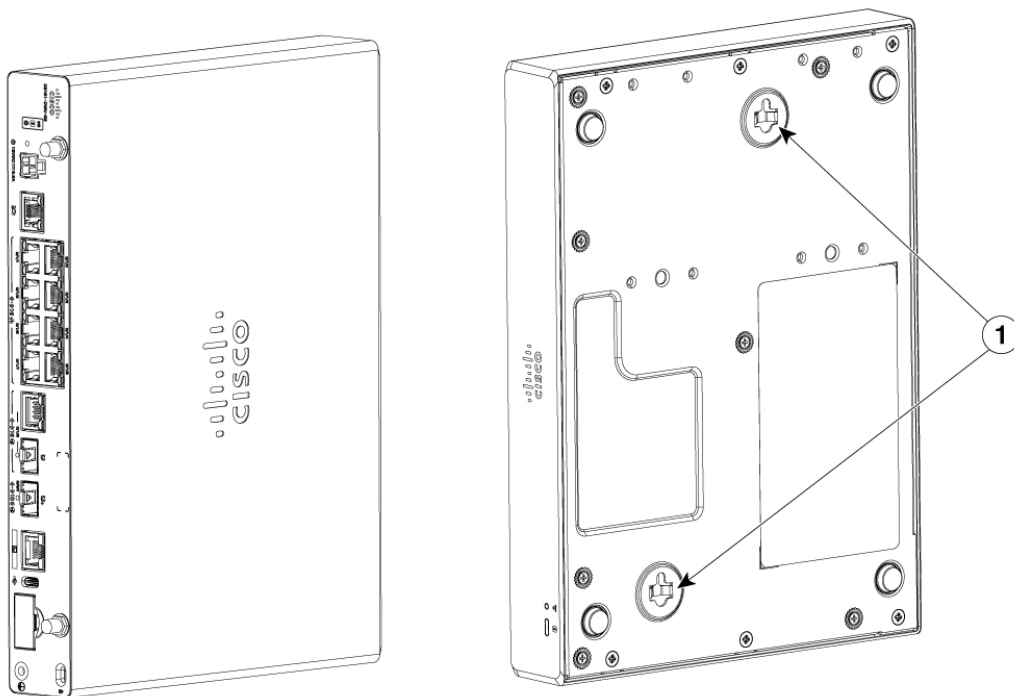

1

Keyhole slots

Horizontal spacing: 2.38 in(60.37 mm)

Vertical spacing: 8.035 in(204.08 mm)

Wall mount using DIN rail brackets

The router is shipped with DIN rail brackets that are to be secured on the bottom side of the chassis. Your chassis installation must allow unrestricted airflow for chassis cooling.

1. Align the din rail brackets to the holes indicated in the listed figure. To attach the DIN rail brackets to the router chassis, use the PHMS screws and the plastic spacers provided for each bracket.

Figure 54: DIN rail bracket installation for C8130-G2 and C8131-G2

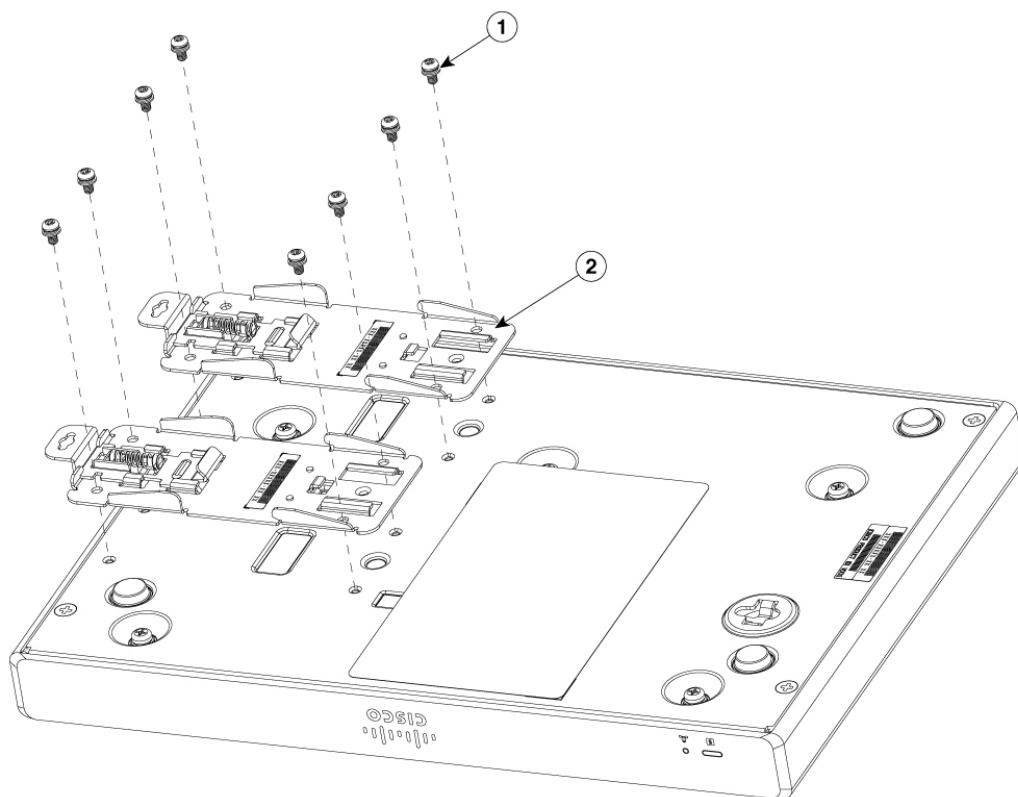

1

PHMS screws

2

DIN rail brackets

Figure 55: DIN rail bracket installation for C8140-G2

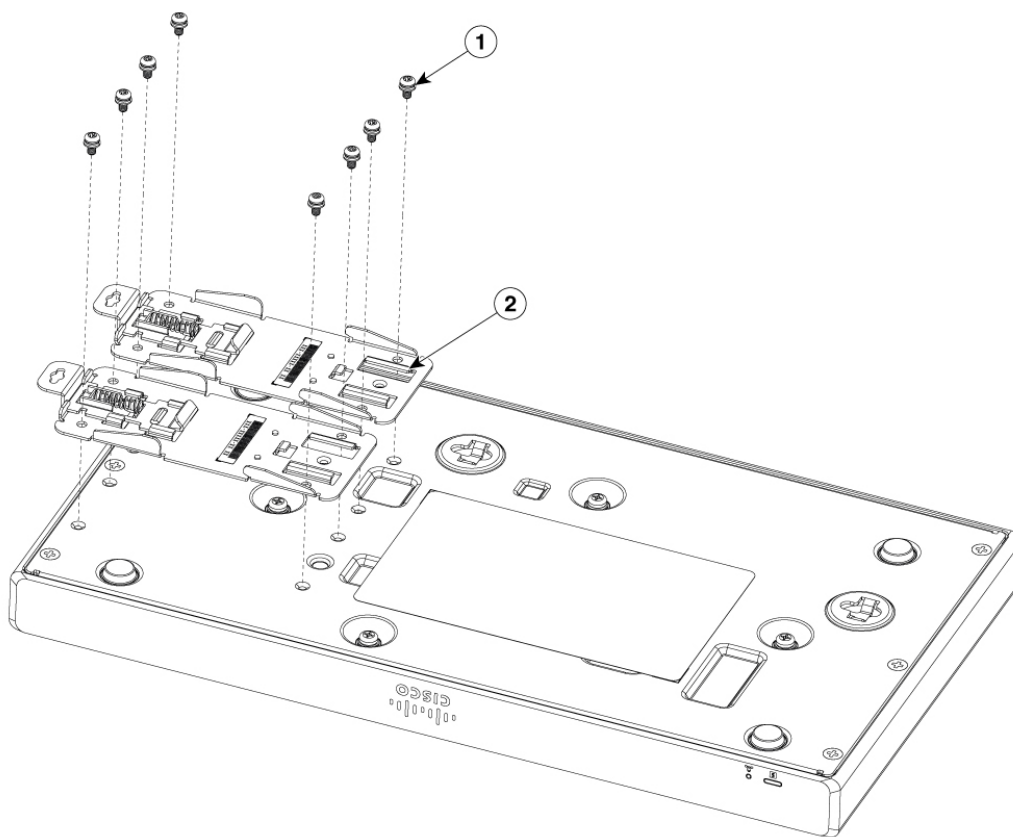

- 1 PHMS screws
- 2 DIN rail brackets

Figure 56: DIN rail bracket installation for C8151-G2 and C8161-G2

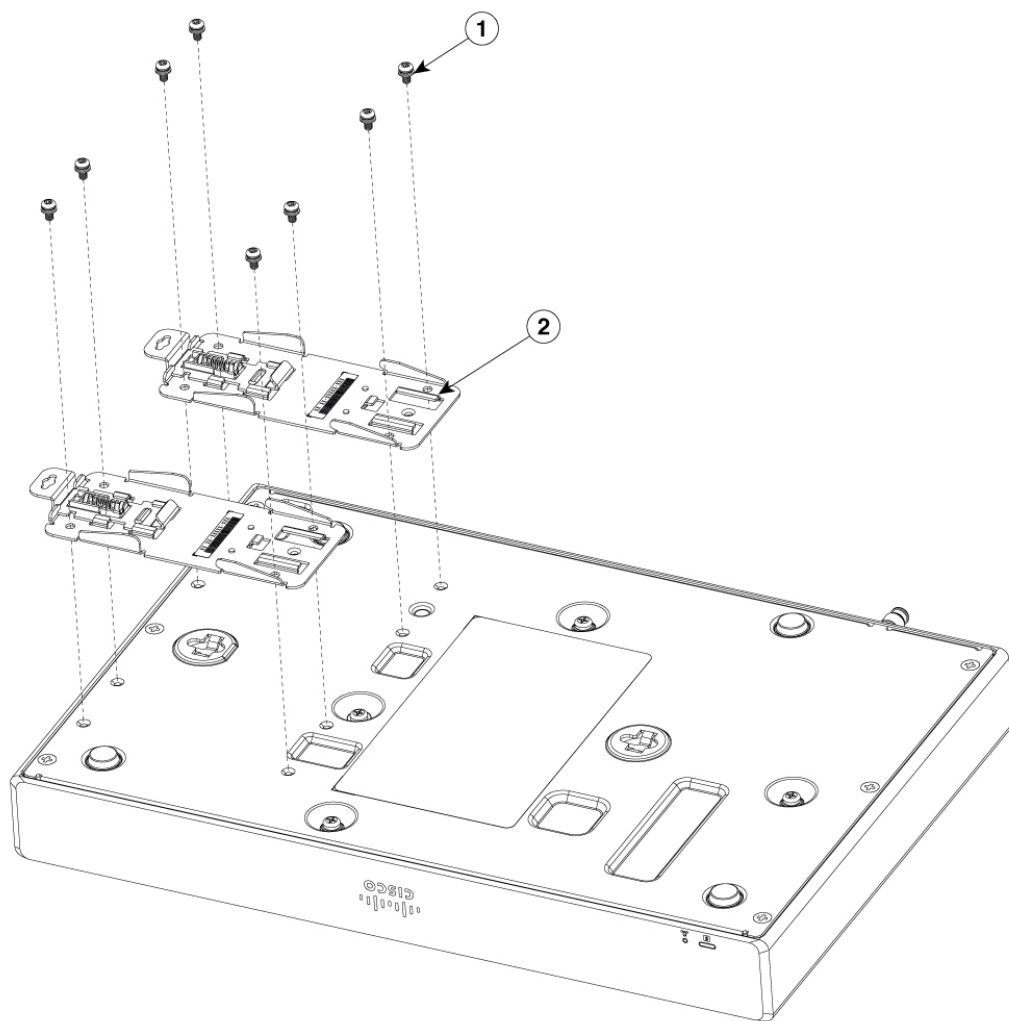

- 1 PHMS screws
- 2 DIN rail brackets

Figure 57: DIN rail bracket installation for C8130-VAI-G2 and C8130-VAP-G2

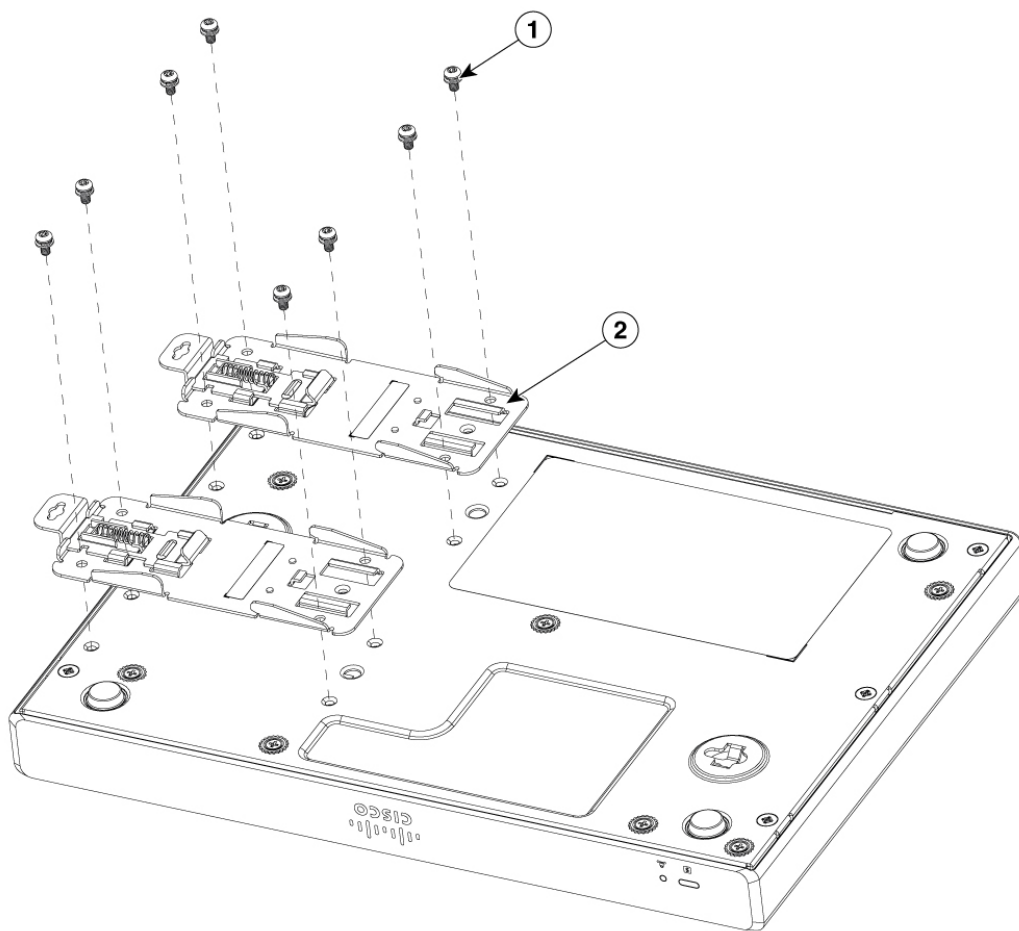

- 1 PHMS screws
- 2 DIN rail brackets

Figure 58: DIN rail bracket installation for C8151-CVAI-G2 and C8151-CVAP-G2

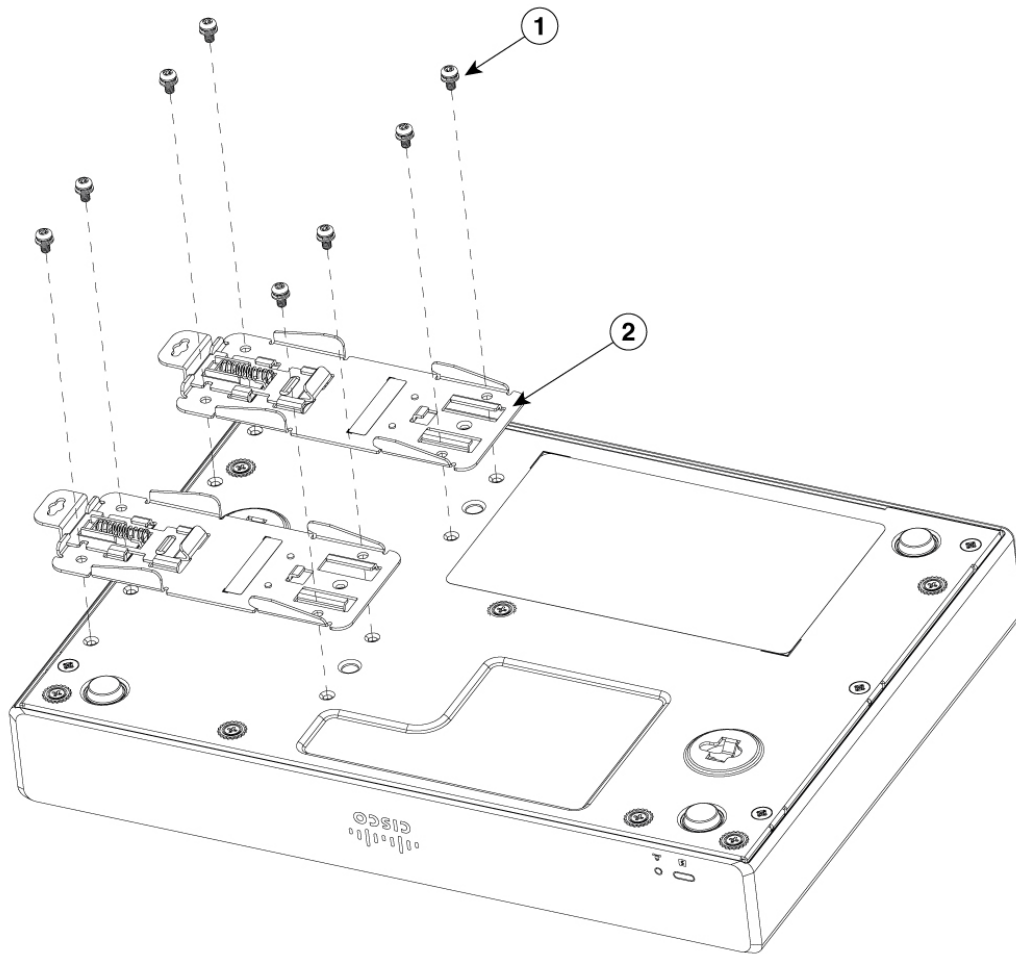

- 1 PHMS screws
- 2 DIN rail brackets

2. Secure the din rail brackets to the router using the PHMS screws and the plastic spacers provided for each bracket.

Figure 59: C8130-G2 and C8131-G2 with attached DIN rail brackets

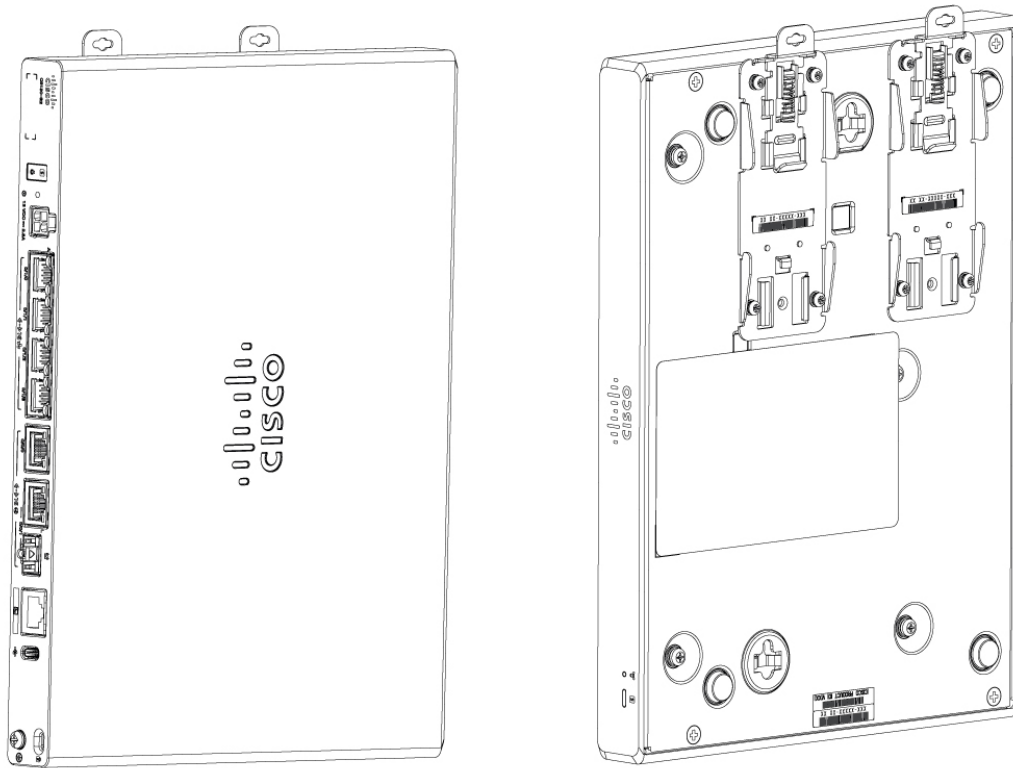

Figure 60: C8140-G2 with attached DIN rail brackets

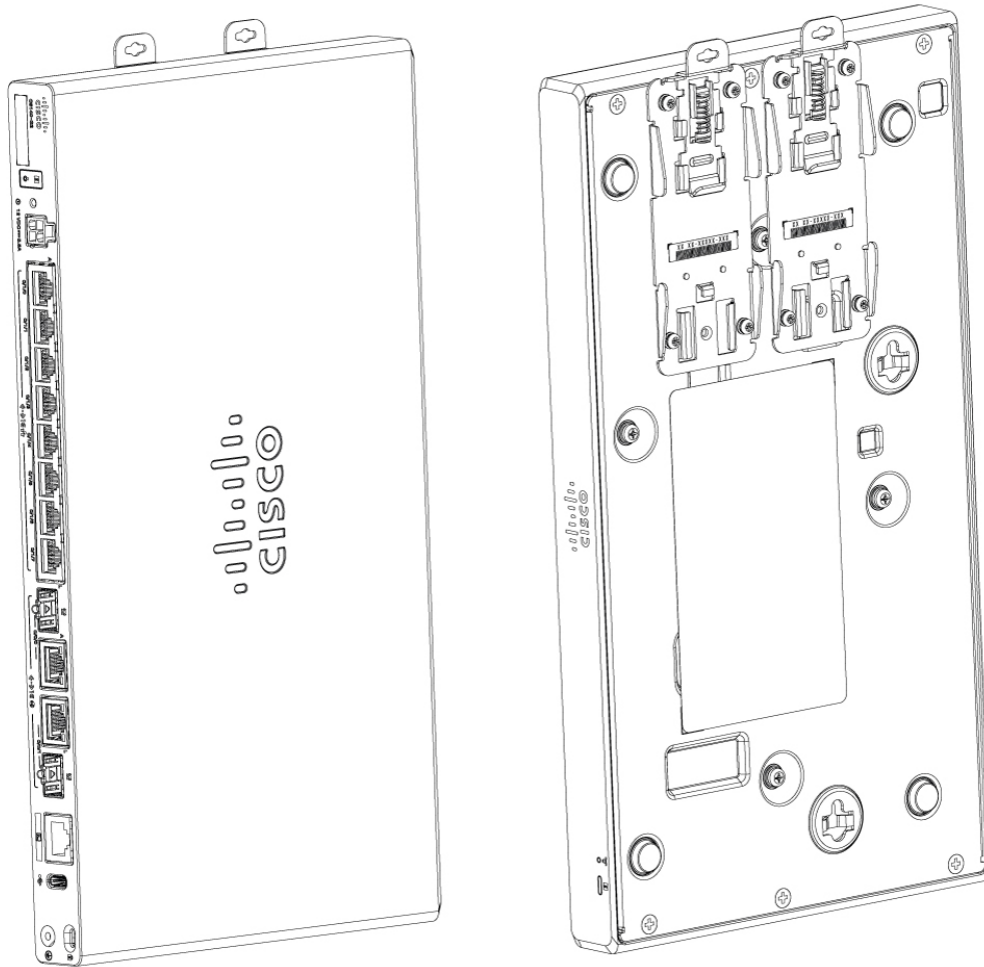

Figure 61: C8151-G2 and C8161-G2 with attached DIN rail brackets

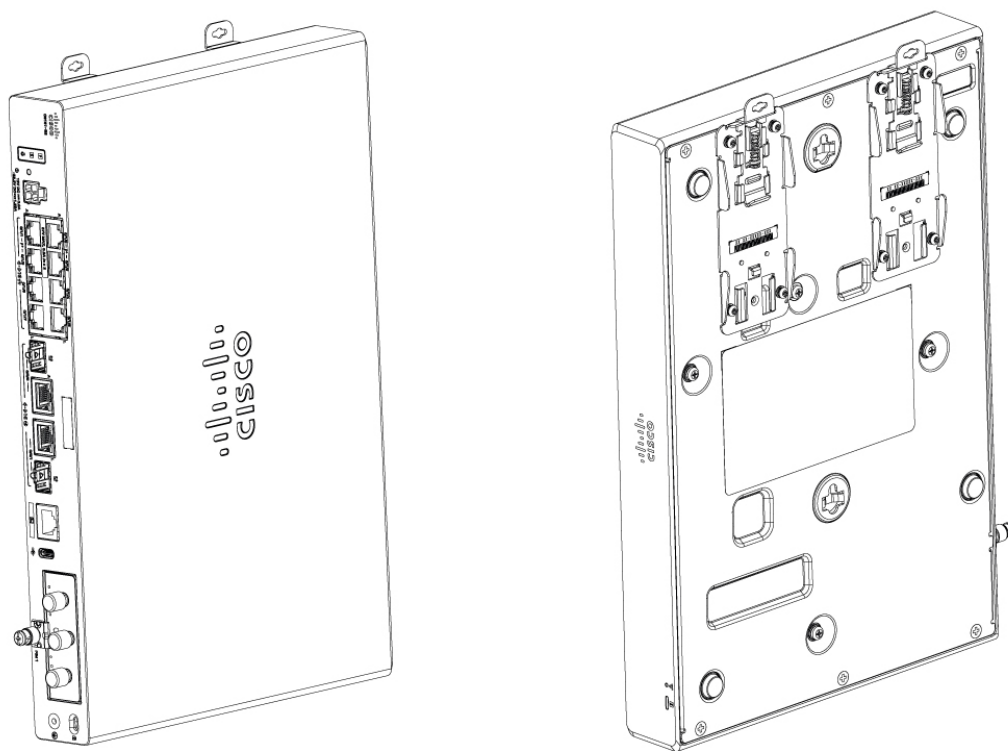

Figure 62: C8130-VAI-G2 and C8130-VAP-G2 with attached DIN rail brackets

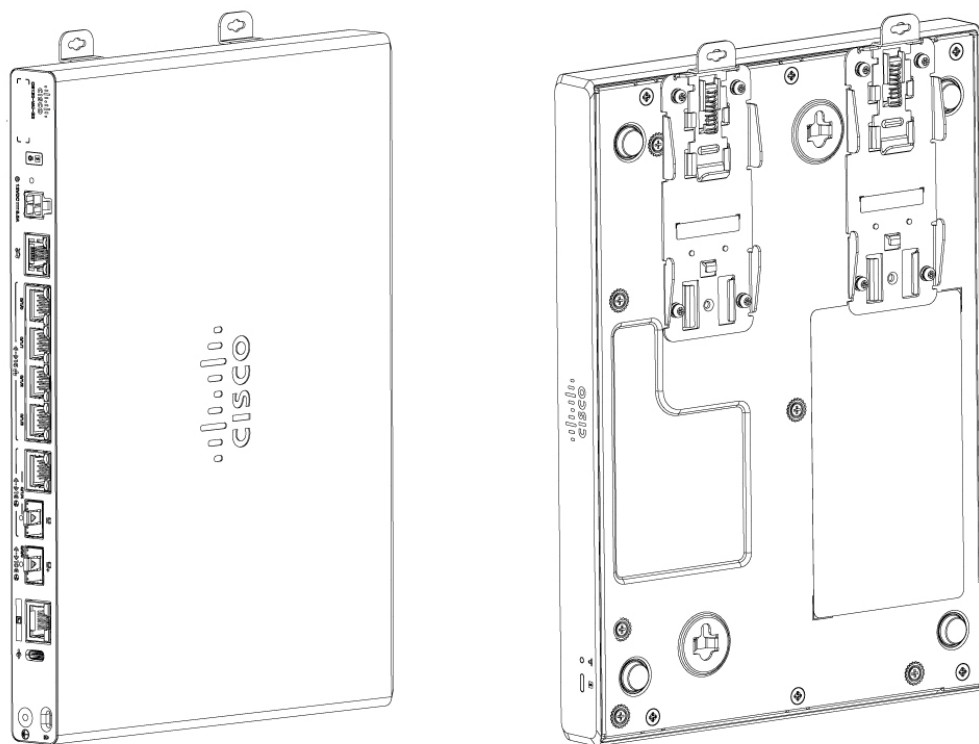
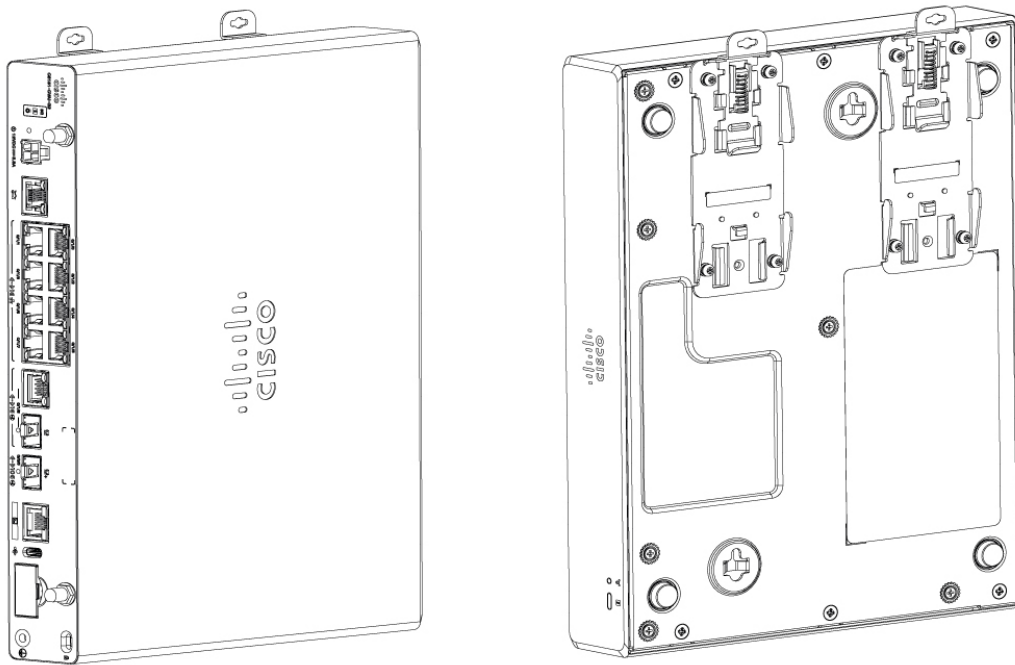

Figure 63: C8151-CVAI-G2 and C8151-CVAP-G2 with attached DIN rail brackets



 **Note**

Do not over-torque the screws. The recommended torque is 8 to 10 inch-lbf (0.9 to 1.1 N-m).

3. Attach the brackets onto the DIN rail to clamp it together.

Figure 64: Mounting C8130-G2 and C8131-G2 using DIN rail brackets

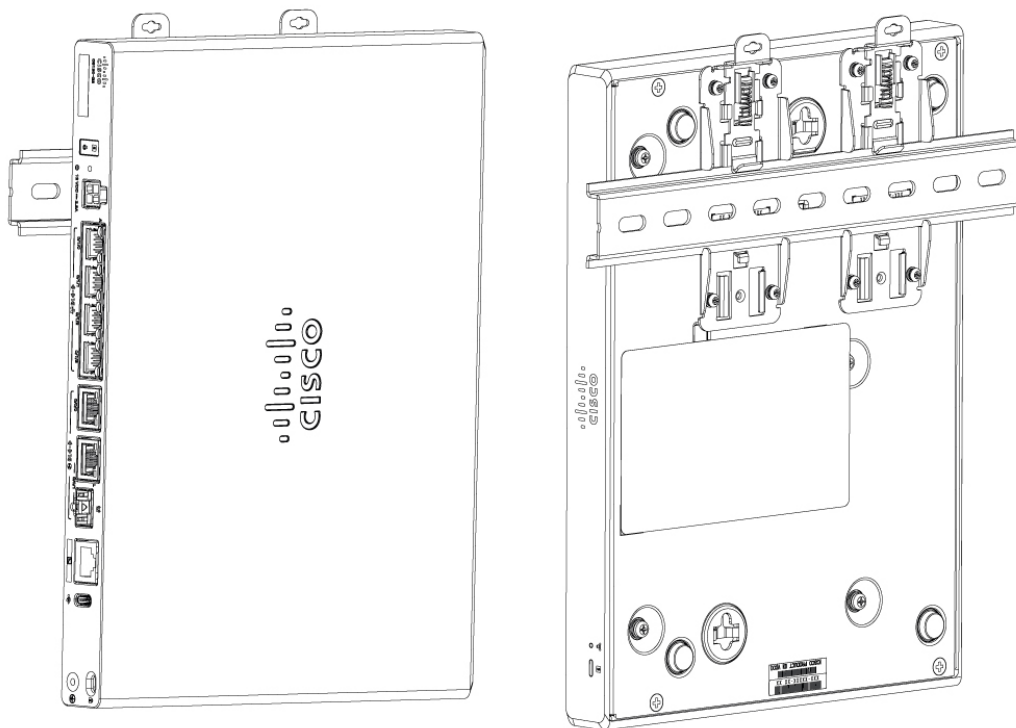

Figure 65: Mounting C8140-G2 using DIN rail brackets

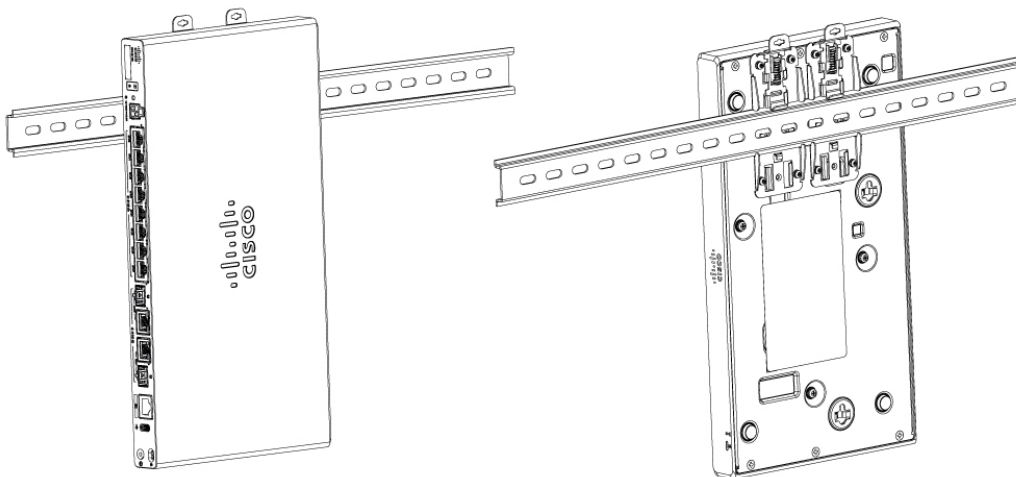

Figure 66: Mounting C8151-G2 and C8161-G2 using DIN rail brackets

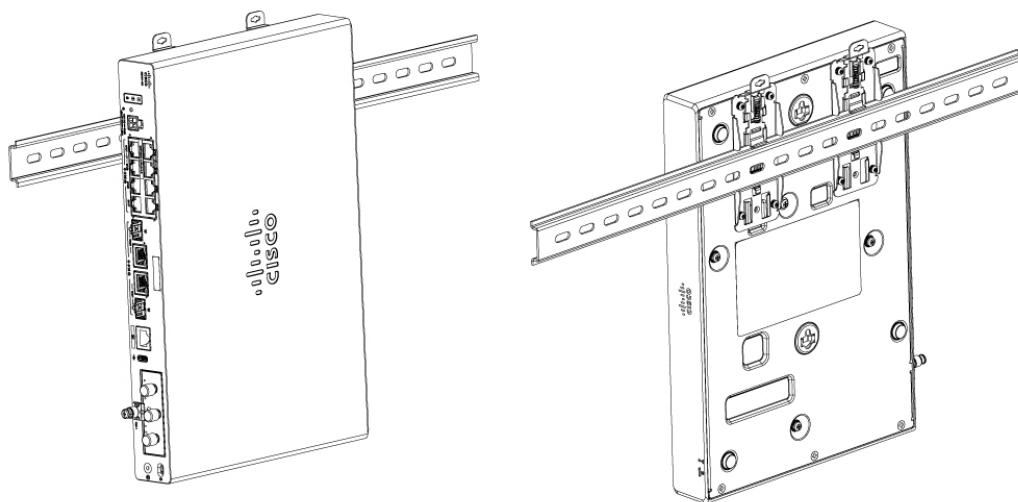

Figure 67: Mounting C8130-VAI-G2 and C8130-VAP-G2 using DIN rail brackets

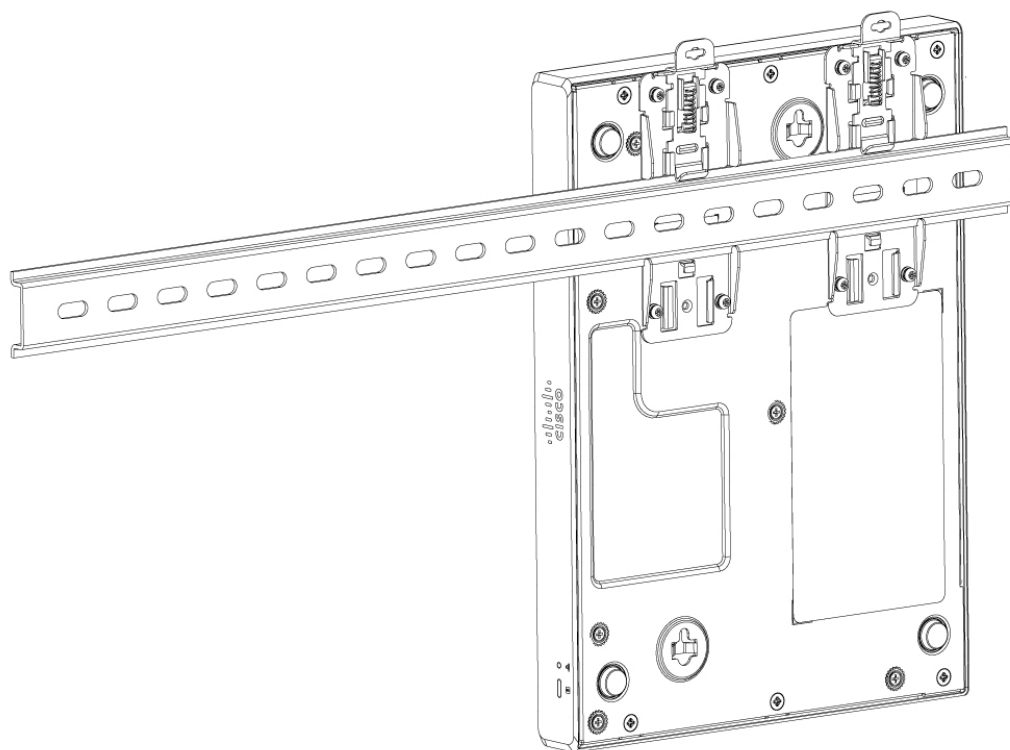
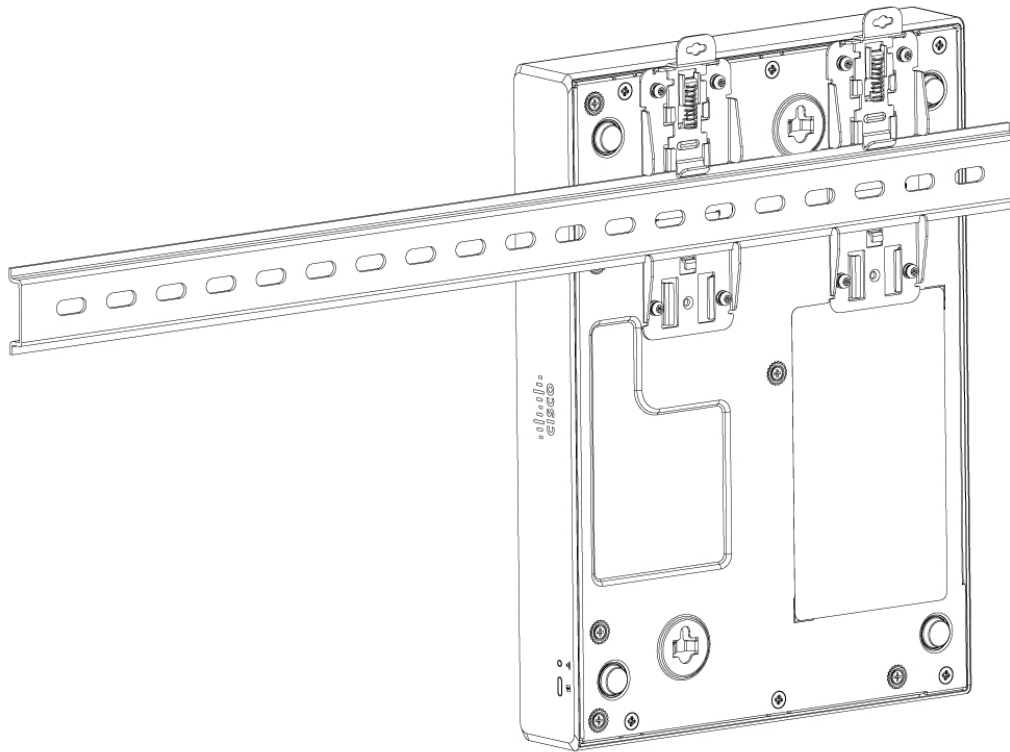

Figure 68: Mounting C8151-CVAI-G2 and C8151-CVAP-G2 using DIN rail brackets



Chassis grounding

After you set up the router, connect the chassis to a reliable earth ground. The ground wire must be installed in accordance with local electrical safety standards. For grounding the chassis, use a copper wire of size of 14 AWG (2 mm²). These components are provided along with the router:

1. Ground Lug
2. UNC 6-32 screws which have a length of about 0.25 inches.

To install the ground connection for your router, perform these steps:

1. Strip one end of the ground wire to the length approximately 0.75 inch (20 mm) for the ground lug.
2. Crimp the ground wire to the ground lug using a crimp tool of the appropriate size.
3. Attach the ground lug to the chassis as shown in the below figures. Tighten the screw; the recommended torque is 8 to 10 inch-lbf (0.9 to 1.1 N-m).

Figure 69: Chassis ground connection - C8130-G2 and C8131-G2

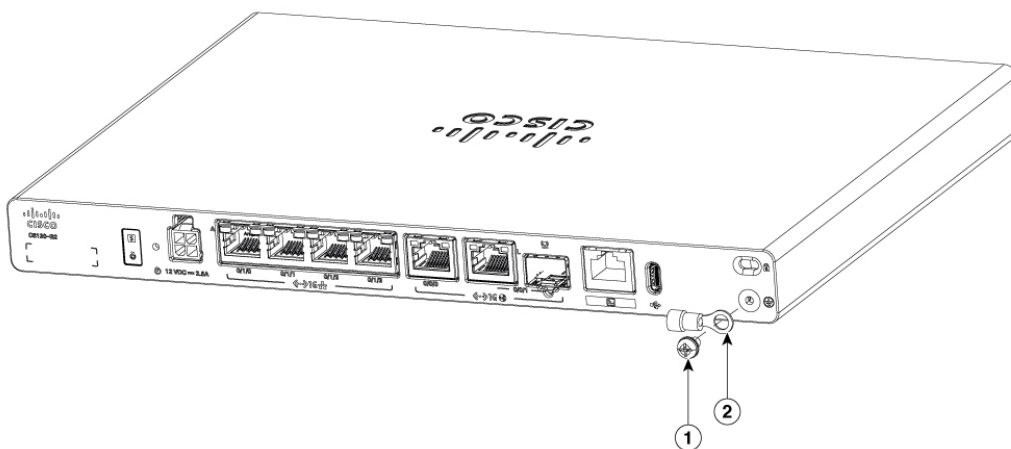

- 1 Screw (UNC 6-32)
- 2 Ground lug

Figure 70: Chassis ground connection - C8140-G2

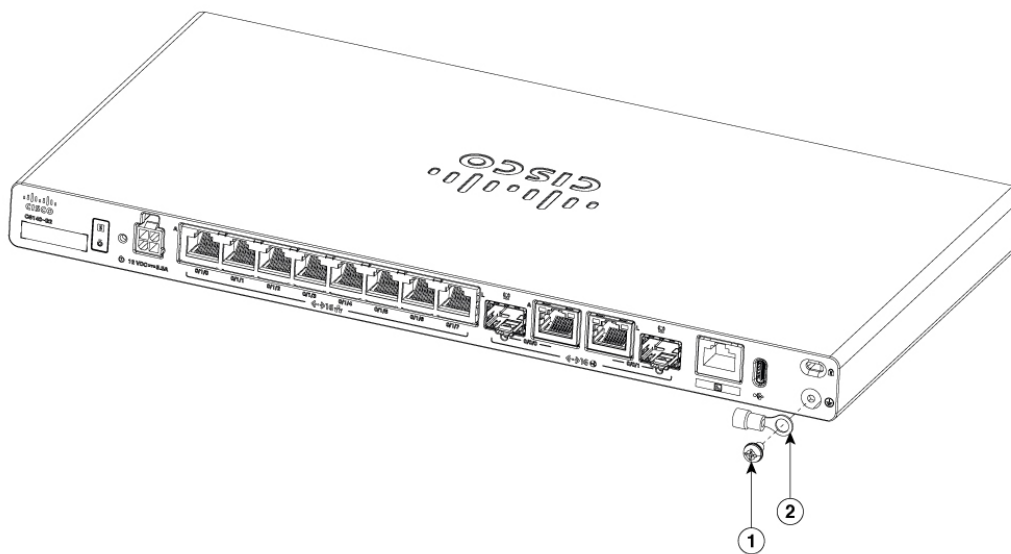

- 1 Screw (UNC 6-32)
- 2 Ground lug

Figure 71: Chassis ground connection - C8151-G2 and C8161-G2

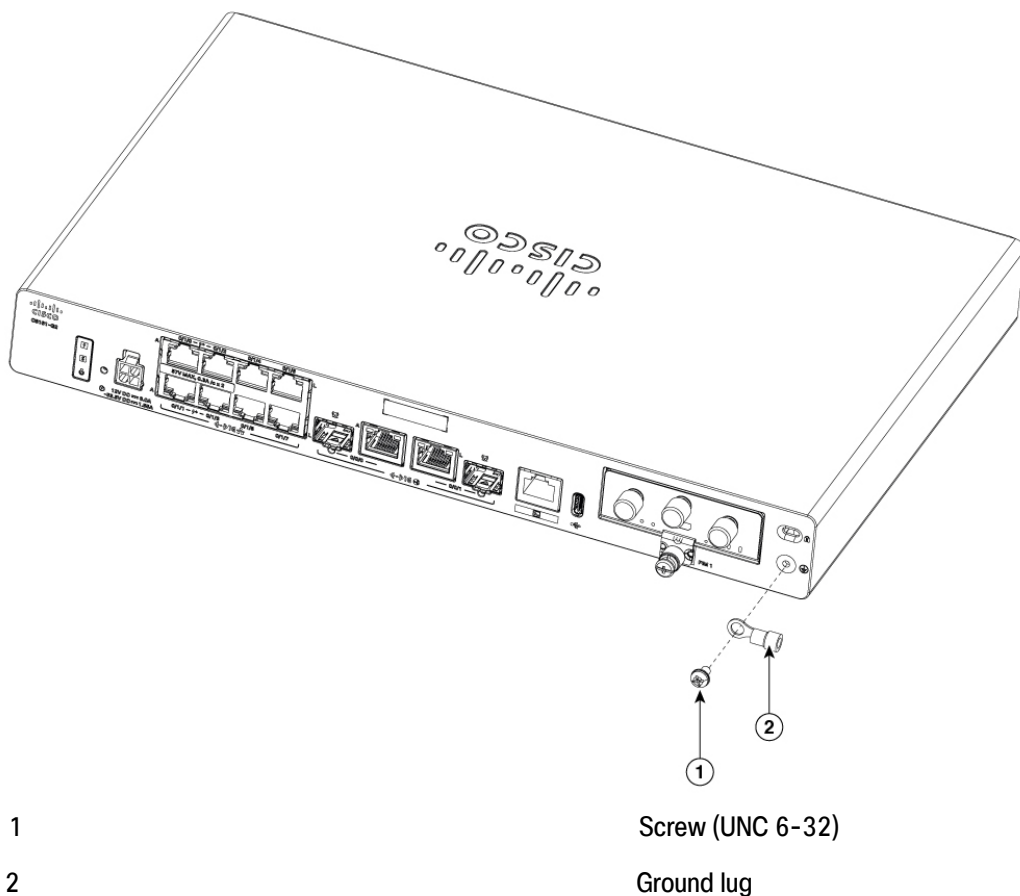

Figure 72: Chassis ground connection - C8130-VAI-G2 and C8130-VAP-G2

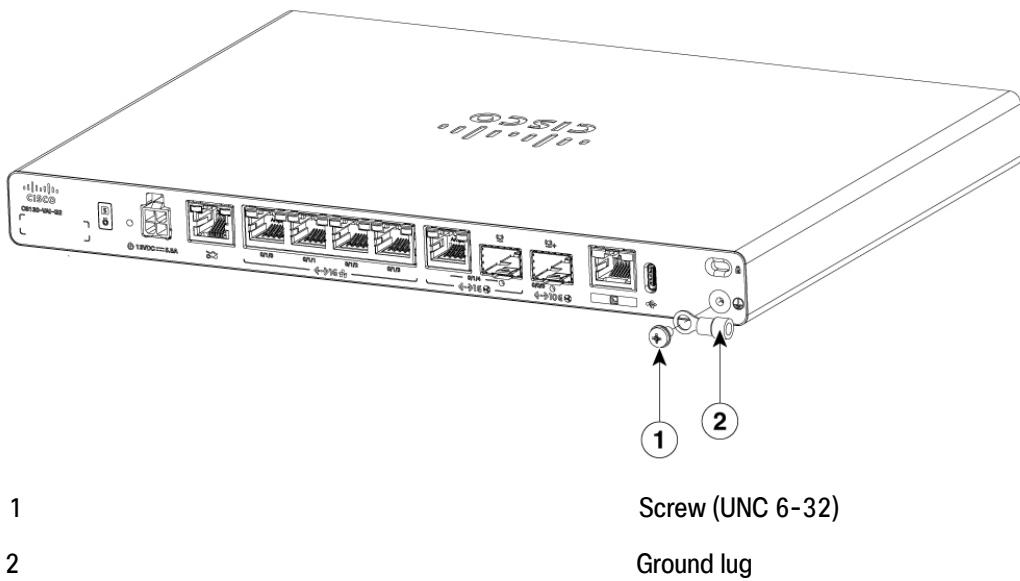
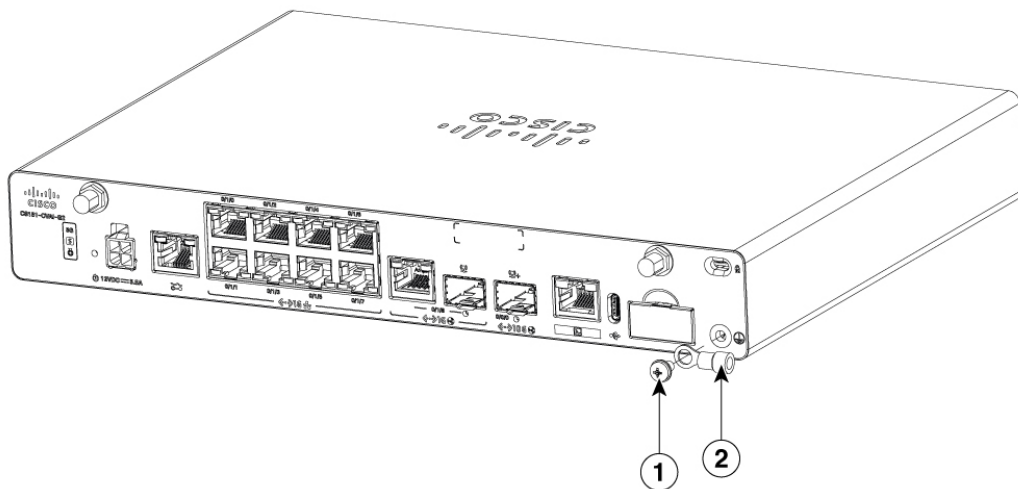

Figure 73: Chassis ground connection - C8151-CVAI-G2 and C8151-CVAP-G2



- 1 Screw (UNC 6-32)
- 2 Ground lug

Ground connection warnings

Details of ground connection warnings:

Warning

Statement 1101—Connected To Grounded Outlet

In the Scandinavian countries (Denmark, Finland, Iceland, Norway, and Sweden) the appliance must be connected to a grounded outlet.

Optical connection SFP warnings

Details of optical connection warnings:

Warning

Statement 1051—Laser Radiation

Invisible laser radiation may be emitted from disconnected fibers or connectors. Do not stare into beams or view directly with optical instruments.

Connect the power cable

Explains power and data connection procedures, outlining how to connect the power cable, set up console access across major operating systems, connect WAN and LAN interfaces, and follow comprehensive cabling guidelines and precautionary measures.

Power supply of the Cisco 8100 Series Secure Routers is an external AC to DC power adapter. The external DC power connector plugs into the router's 4 points power connector.

The router does not have a power button. Refer to the below listed details to power on/off the router:

- To power on the router - you can locate the power cable and connect it to a power source.
- To power off the router - unplug the power cord from the back of the router or gently pull the power cable from the router or the wall outlet.

Figure 74: Power cable - C8130-G2 and C8131-G2

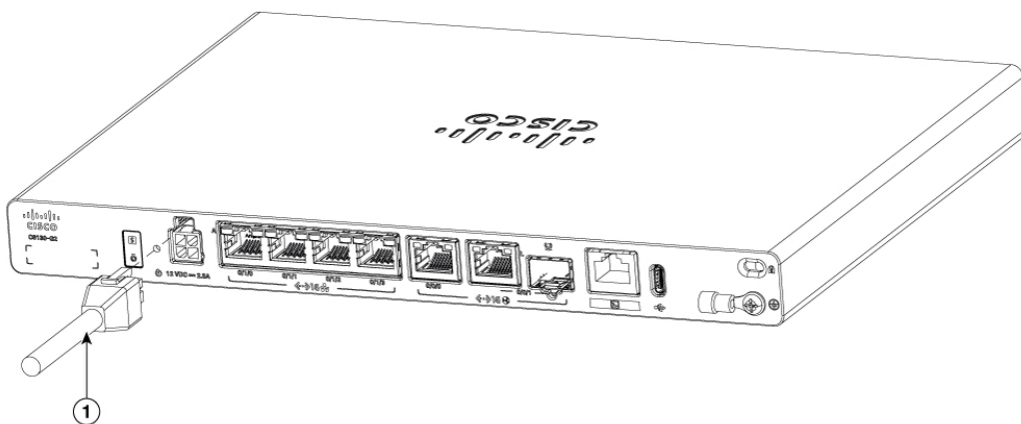

1

Power cable

Figure 75: Power cable - C8140-G2

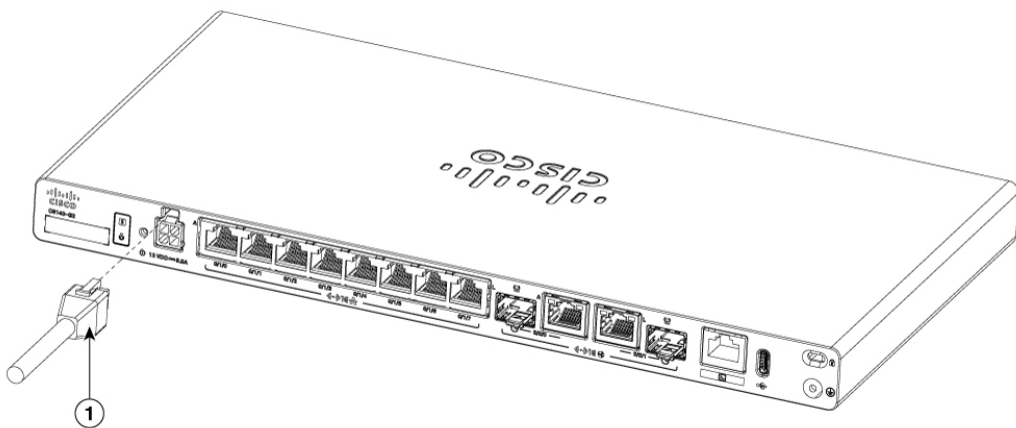

1 Power cable

Figure 76: Power cable - C8151-G2 and C8161-G2

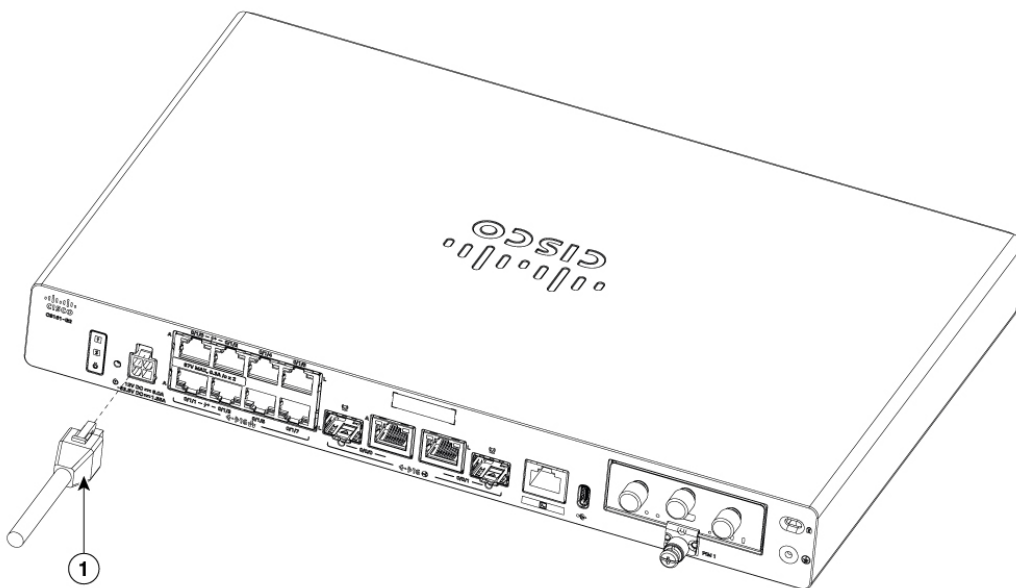

1 Power cable

Figure 77: Power cable - C8130-VAI-G2 and C8130-VAP-G2

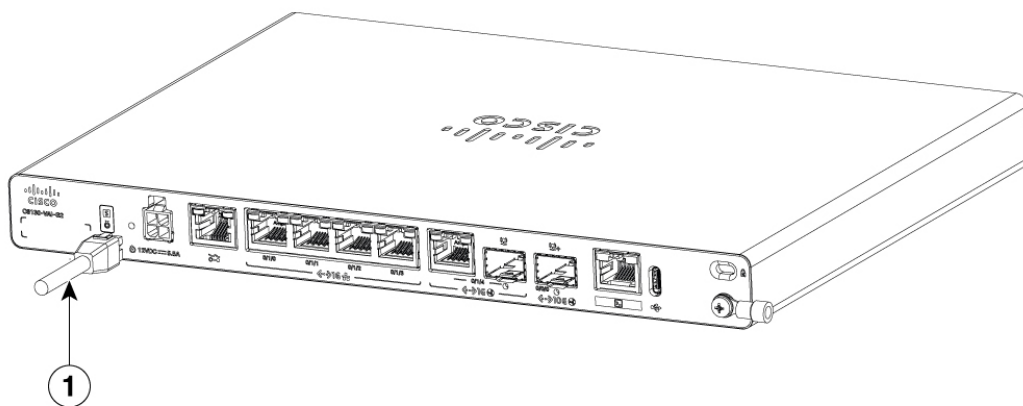

1

Power cable

Figure 78: Power cable - C8151-CVAI-G2 and C8151-CVAP-G2

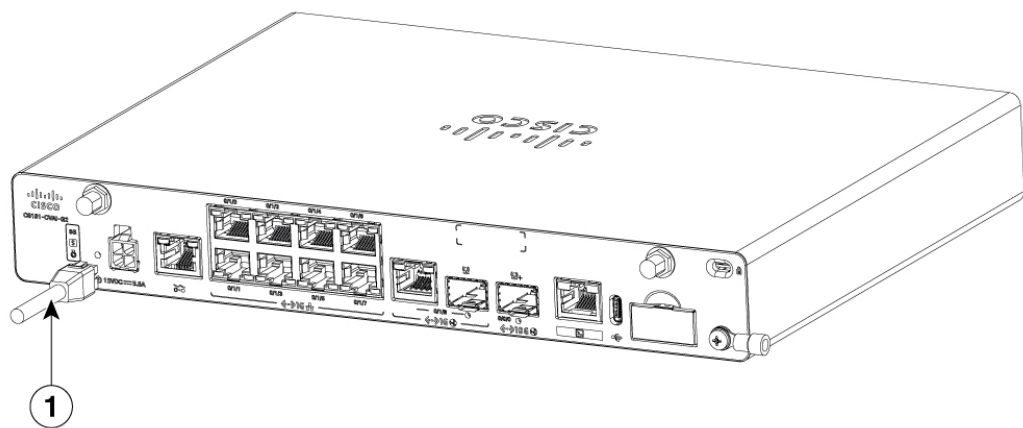

1

Power cable

Connect the router to a console

The Cisco 8100 Series Secure Routers contains a RJ45 console port. This port provides administrative access to the router through a console terminal or a PC.

Use the RJ45 console port on the router to access the Cisco Internetwork Operating System (IOS XE) command line interface (CLI) on the router and perform configuration tasks. A terminal emulation program is required to establish communication between the router and a PC.

To configure the router through the CLI, you must establish a connection between the router console port and either a PC or a terminal.

Use the cables and adapters as listed in this table to establish a local or remote connection.

Table 9: Local and remote connections

Port type	Cable	Action
Serial (RJ45)	RJ45 serial console cable	Connecting to the serial port with terminal emulation program.

Connect to the serial port with Microsoft Windows

Configure your Microsoft Windows PC to access a router console port using a USB or serial connection and a terminal emulator.

To establish a physical connectivity between the router and a PC, you need to install a Microsoft Windows USB.

This procedure describes how to connect a Microsoft Window USB port to a console port.

1. Connect the end of the console cable with the RJ45 connector to the light blue console port on the router.
2. Connect the end of the cable with the DB-9 connector (or USB Type-A) to the terminal or PC. If your terminal or PC has a console port that does not accommodate a DB-9 connector, you must provide an appropriate adapter for that port.
3. Start a terminal emulator application to communicate with the router. Configure the software with these parameters:
 - 9600 baud
 - 8 data bits
 - no parity
 - 1 stop bit
 - no flow control

Connect to the console port with Mac OS X

This procedure describes how to connect a Mac OS X system USB port to the console using the built in OS X Terminal utility.

1. Use the Finder to go to Applications > Utilities > Terminal.
2. Connect the OS X USB port to the router.
3. Enter the commands to find the OS X USB port number.

```
macbook:user$ cd /dev
macbook:user$ ls -ltr /dev/*usb*
crw-rw-rw-  1 root  wheel      9,  66 Apr  1 16:46 tty.usbmodem1a21
DT-macbook:dev user$
```

4. Connect to the USB port with the listed command followed by the router USB port speed.

```
macbook:user$ screen /dev/tty.usbmodem1a21 9600
```

To disconnect the OS X USB console from the Terminal window

Enter Ctrl-a followed by Ctrl-\

Connect to the console port with Linux

This procedure shows how to connect a Linux system USB port to the console using the built in Linux terminal utility.

1. Open the Linux terminal window.
2. Connect the Linux USB port to the router.
3. Enter the following commands to find the Linux USB port number.

```
root@usb-suse# cd /dev
root@usb-suse /dev# ls -ltr *ACM*
crw-r--r--  1 root    root      188,   0 Jan 14 18:02 ttyACM0
root@usb-suse /dev#
```

4. Connect to the USB port with the following command followed by the router USB port speed.

```
root@usb-suse /dev# screen /dev/ttyACM0 9600
```

Note

To disconnect the Linux USB console from the terminal window:

Enter Ctrl-a followed by : then quit.

Connect WAN and LAN interfaces

This section describes how to connect WAN and LAN interface cables.

Ports and cabling

This section summarizes typical WAN and LAN connections for Cisco 8100 Series Secure Routers. The connections summarized here are described in detail in the Cisco Modular Access Router Cable Specifications document on cisco.com.

Table 10: WAN and LAN connections

Port	Port Type	Connection	Cable
Ethernet	RJ45	Ethernet hub or Ethernet switch	Category 5 or higher Ethernet
Gigabit Ethernet SFP, optical	LC	1000BASE-SX, -LX, -LH, -ZX, -CWDM	Optical fiber as specified on applicable data sheet
Gigabit Ethernet SFP, copper	RJ45	1000BASE-T	Category 5, 5e, 6 UTP
XGSPON/10GBASE-T	LC	SFP-10G-ONT20-I, SFP-10G-T-X	Optical fiber as specified on applicable data sheet

 **Note**

The SFP slot supports pluggables compliant with 400KHz I2C clock speed (Fast Mode). Pluggables that operate only at 100KHz I2C clock speed (Standard Mode), such as certain v1 GLC-EX-SMD and GLC-ZX-SMD models, are not supported.

Connection procedures and precautions

After you have installed the router chassis, perform these steps to connect the WAN and LAN interfaces:

1. Connect each WAN and LAN cable to the appropriate ports on the chassis.
2. Position the cables carefully so that you do not strain the connectors.
3. Organize cables in bundles so that cables do not intertwine.
4. Inspect the cables to make sure that the routing and bend radius is satisfactory. If necessary, reposition the cables.
5. Install cable ties in accordance with site requirements.

4 Install and Upgrade Field Replaceable Units

Topics:

- [Install a Pluggable Interface Module](#)
- [LED behaviors](#)
- [Install a Nano-SIM card into the router](#)
- [Removal of SFP-10G-ONT20-I XGSPON optical module](#)

Install a Pluggable Interface Module

Details installing a pluggable interface module, including antenna insertion, connector specifications for embedded 5G devices, RF band mapping, and micro SIM integration, ensuring comprehensive module setup and connectivity.

Warning

Statement 1255—Laser Compliance Statement

Pluggable optical modules comply with IEC 60825-1 Ed. 3 and 21 CFR 1040.10 and 1040.11 with or without exception for conformance with IEC 60825-1 Ed. 3 as described in Laser Notice No. 56, dated May 8, 2019.

1. Insert and then gently push the Cellular pluggable into the pluggable slot of C8151-G2 or C8161-G2 until firmly fixed.

Figure 79: Pluggable Interface Module installation for C8151-G2 and C8161-G2

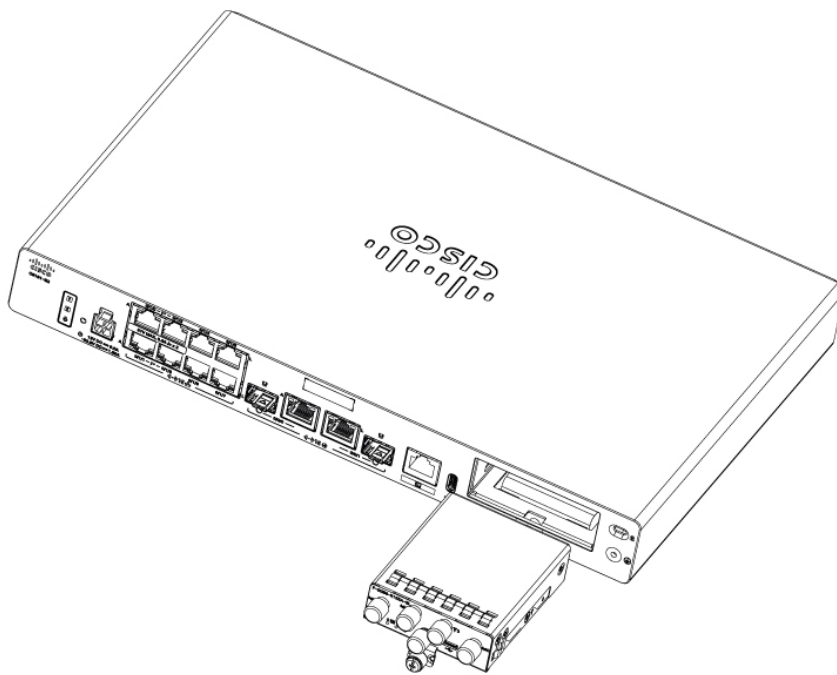

2. Tighten the screw, the recommended torque is 10-12 in-lb.

Figure 80: C8151-G2 and C8161-G2 with attached Pluggable Interface Module

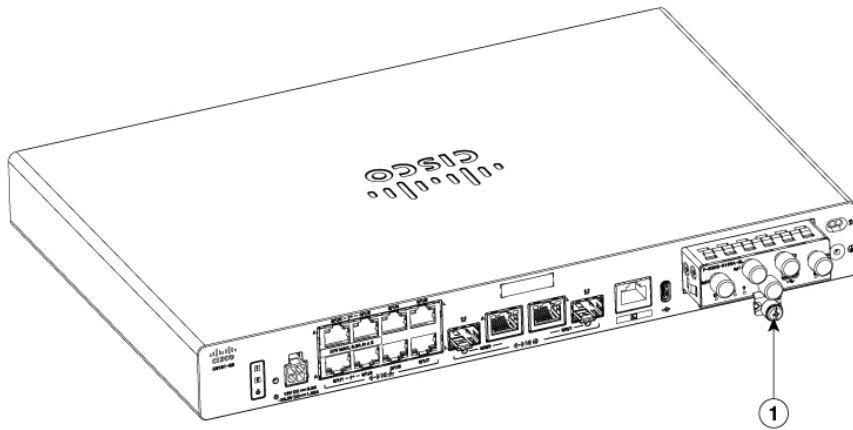

1 Screw

Figure 81: LTE Pluggable Interface Module - P-LTEA7-EAL

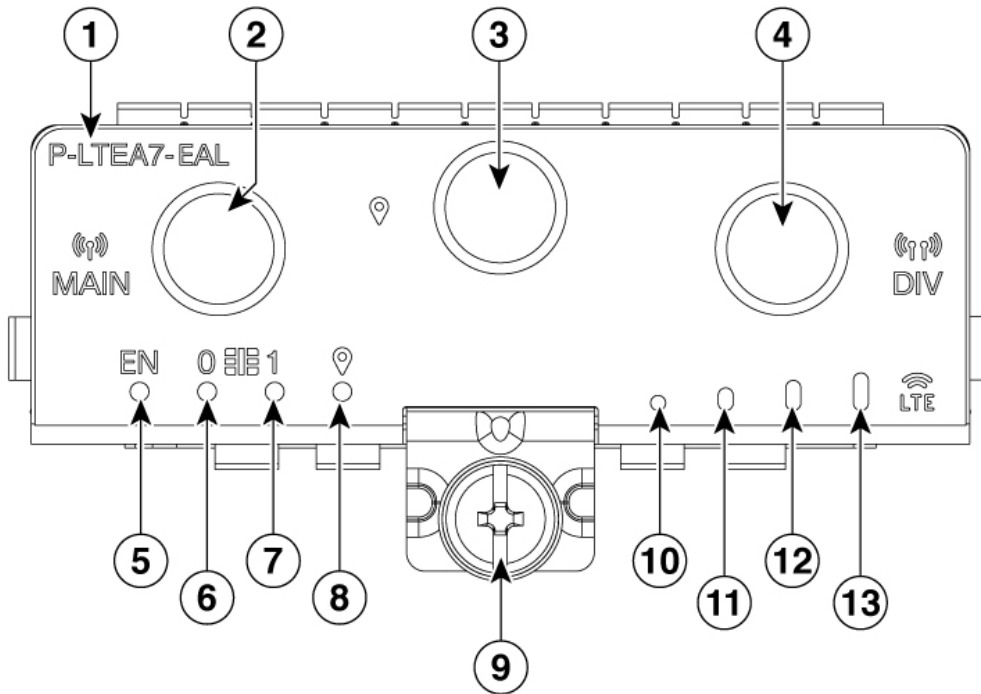

- 1 Product Identification Number (PID)
- 2 Main antenna connector (SMA)
- 3 GPS connector (SMA)
- 4 Diversity antenna connector (SMA)
- 5 Enable LED
- 6 SIM 0 LED
- 7 SIM 1 LED

- 8 GPS LED
- 9 M3.5 thumbscrew
- 10 RSSI 0
- 11 RSSI 1
- 12 RSSI 2
- 13 RSSI 3

Figure 82: LTE Pluggable Interface Module - P-LTEA7-JP

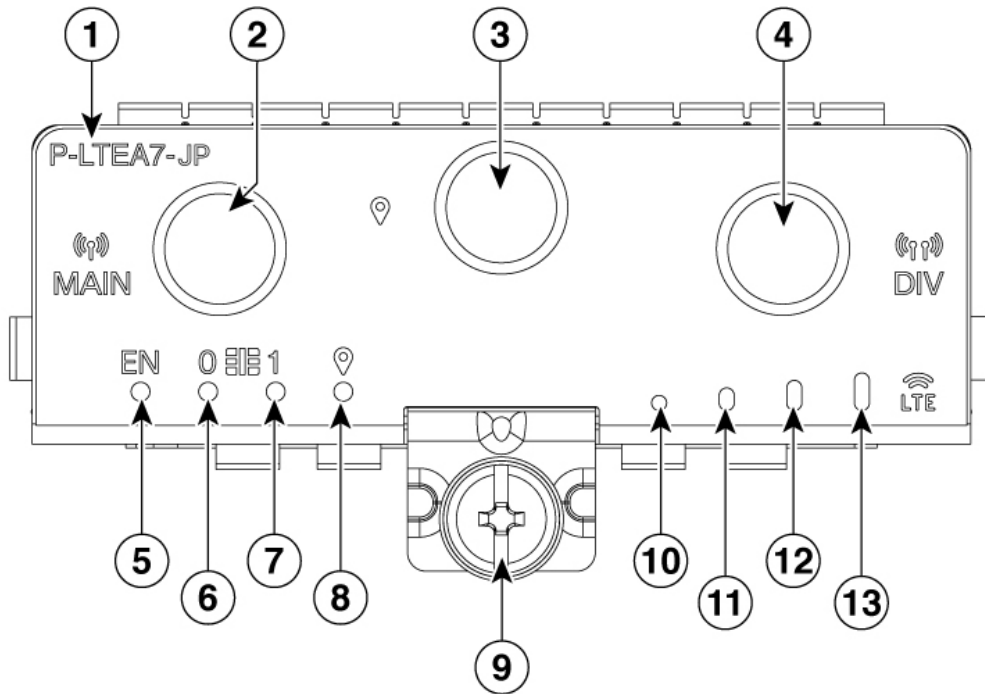

- 1 Product Identification Number (PID)
- 2 Main antenna connector (SMA)
- 3 GPS connector (SMA)
- 4 Diversity antenna connector (SMA)
- 5 Enable LED
- 6 SIM 0 LED
- 7 SIM 1 LED
- 8 GPS LED
- 9 M3.5 thumbscrew
- 10 RSSI 0
- 11 RSSI 1

- 12 RSSI 2
- 13 RSSI 3

Figure 83: LTE Pluggable Interface Module - P-LTEA7-NA

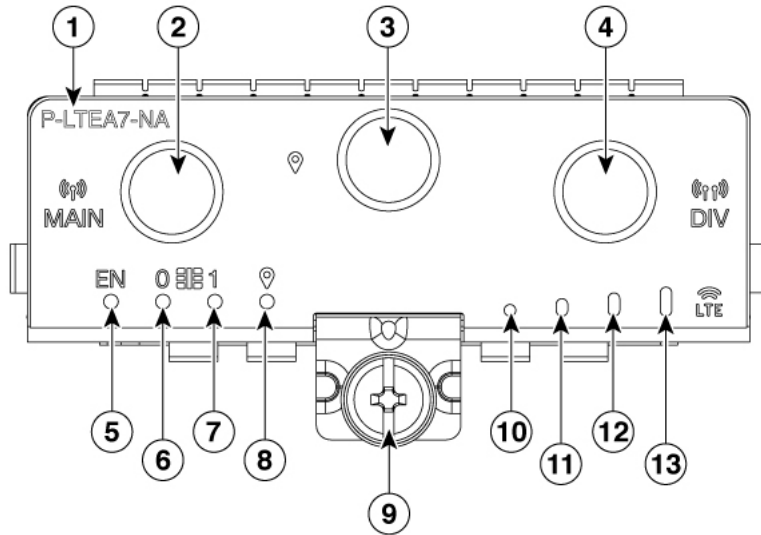

- 1 PID
- 2 Main antenna slot (SMA)
- 3 GPS (SMA)
- 4 Diversity antenna slot (SMA)
- 5 Enable LED
- 6 SIM 0 LED
- 7 SIM 1 LED
- 8 GPS LED
- 9 M3.5 thumbscrew
- 10 RSSI 0
- 11 RSSI 1
- 12 RSSI 2
- 13 RSSI 3

Figure 84: 5G Pluggable Interface Module - P-5GS6-R16SA-GL

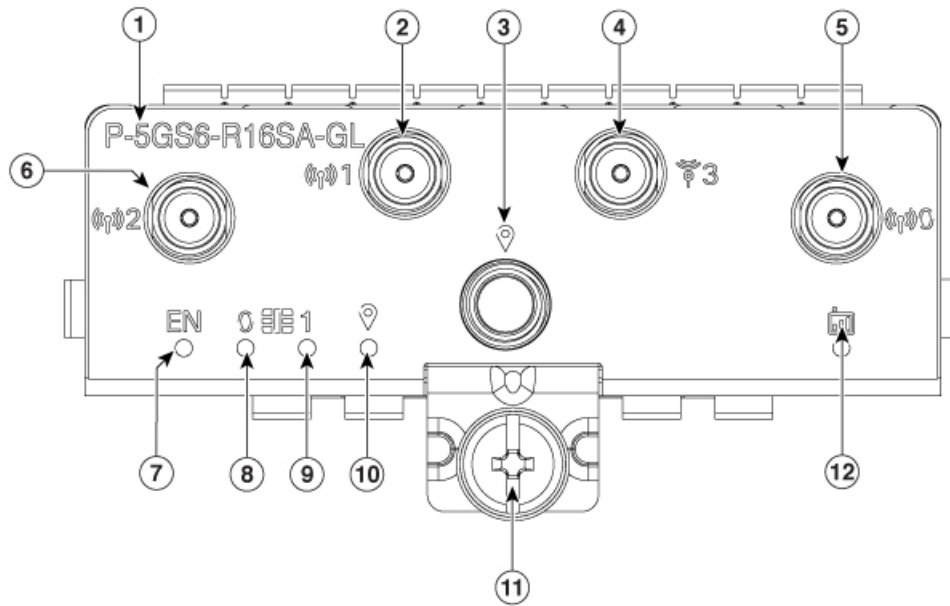

- | | |
|----|--------------------------------------|
| 1 | PID |
| 2 | Main antenna slot 1 (SMA) |
| 3 | GPS (SMA) |
| 4 | Antenna slot 3 (SMA, reception only) |
| 5 | Antenna slot 0 (SMA) |
| 6 | Antenna slot 2 (SMA) |
| 7 | Enable LED |
| 8 | SIM 0 LED |
| 9 | SIM 1 LED |
| 10 | GPS LED |
| 11 | M3.5 thumbscrew |
| 12 | Service LED |

Insert antenna into the Pluggable Interface Module

To insert the antenna in the Pluggable Interface Module, perform these steps:

1. Insert and tighten antennas in the antenna slots as per the sequence mentioned in the figure.

Figure 85: Attaching the antennas

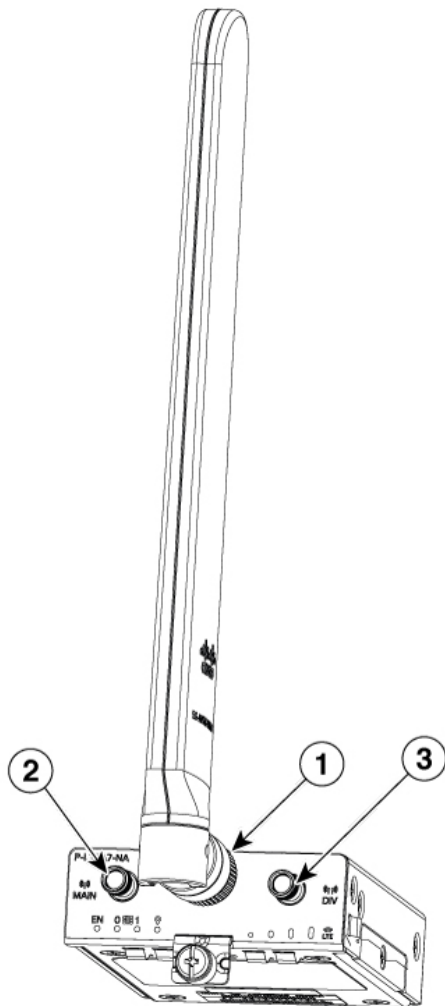

 **Note**

You need to install antennas as per the sequence to get enough space to tighten antennas in all the antenna slots.

2. After installing the antennas, adjust the antenna orientation by spacing out each of them equally until they are spread out. This is significant as it helps in getting higher RF performance.

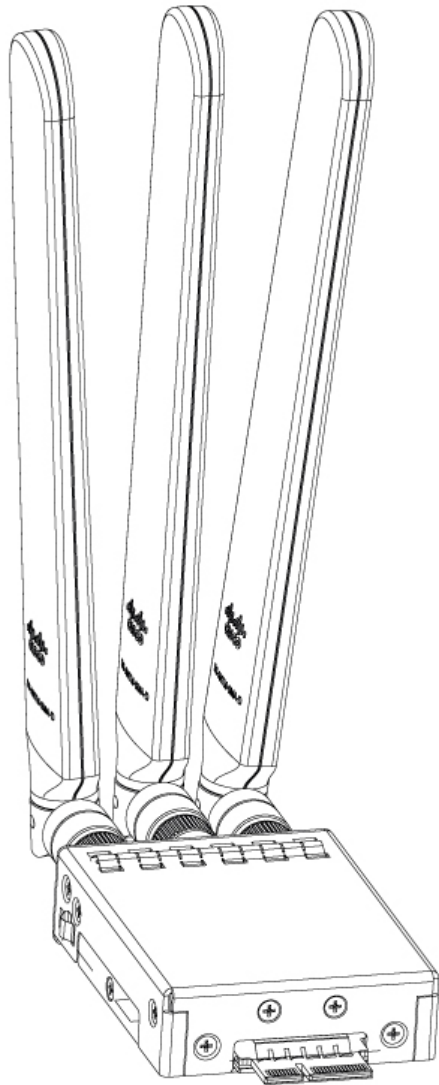

Antenna connector details for embedded 5G devices

This section lists the antenna SMA connector locations for devices with embedded 5G.

The antenna SMA connector (labeled as #3) enables connection to an external antenna, optimizing 5G performance on the C8151-CVAI-G2 and C8151-CVAP-G2 devices, as shown in the image.

Figure 86: C8151-CVAI-G2 and C8151-CVAP-G2 - Front view

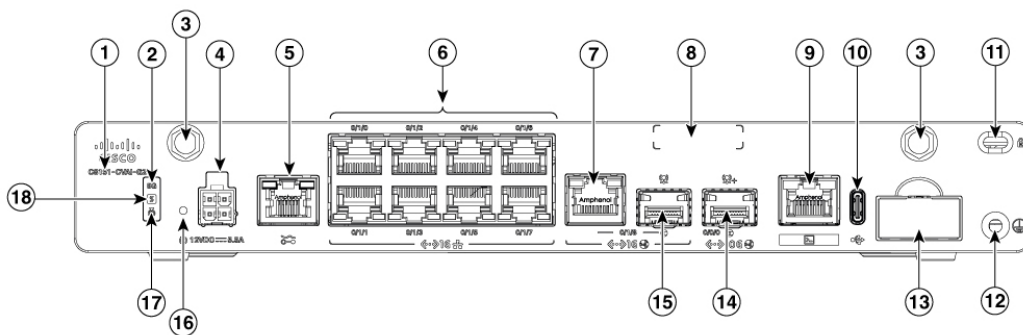

RF band mapping for antenna ports

This table lists the RF band mapping for antenna ports.

Table 11: RF band mapping for antenna ports for P-5GS6-R16SA-GL

Radio Access Technology (RAT)	Bands	Tx antennas		Rx antennas				GNSS antenna
		Default	Alternate Path	ANT0	ANT1	ANT2	ANT3	
-	-	Default	Alternate Path	ANT0	ANT1	ANT2	ANT3	GPS
5G NR Sub-6G	29	-	-	Y	-	Y	-	-
	38, 41	ANT2	ANT0	Y	Y	Y	Y	-
	48	ANT3	ANT1	Y	Y	Y	Y	-
	75, 76	-	-	Y	Y	Y	Y	-
	77, 78	ANT3	ANT1	Y	Y	Y	Y	-
	79	ANT3	ANT1	Y	Y	Y	Y	-
LB LTE/ 5G NR Sub-6G	5, 8, 12, 13, 14, 17, 18, 19, 20, 26, 28, 71	ANT0	-	Y	-	Y	-	-
MB/HB LTE/ 5G NR Sub-6G	1, 2, 3, 4, 7, 25, 30, 39, 40, 66, 70	ANT0	-	Y	Y	Y	Y	-
LTE	29	-	-	Y	-	-	Y	-
	34	ANT0	-	Y	-	Y	-	-
	46	-	-	Y	-	-	Y	-
	32	-	-	Y	Y	Y	Y	-
	38	ANT0	-	Y	Y	Y	Y	-
	41	ANT0	ANT2	Y	Y	Y	Y	-
	42, 43, 48	ANT3	ANT1	Y	Y	Y	Y	-
WCDMA	1, 2, 4, 5, 8, 19	ANT0	-	Y	-	Y	-	-
GNSS	-	-	-	-	-	-	-	L1

Insert Micro-SIM into a Pluggable Interface Module

This section describes how to insert a Micro-SIM card into a Cellular Pluggable Module. To insert the Micro-SIM cards into a Cellular Pluggable Module, follow these instructions:

1. Place the pluggable module on its bottom side, remove the SIM door screw, use a #1 Philips screwdriver for removing the screws, and then carefully remove the Micro-SIM cover from the pluggable module.

 **Note**

Ensure to use the correct tool for removing the Micro-SIM door.

2. Slot 1 and slot 0 are the Micro-SIM slots.

 **Caution**

Do not touch any part of the exposed PCB circuit area when the Micro-SIM cover is removed.

3. Install SIM 0 and SIM 1 in their respective slots. SIM 0 or SIM 1 is marked on the pluggable interface module above the Micro-SIM cover. The SIM icons show the correct orientation required to install the SIM into each respective connector (SIM connectors are a push-push type). To install, insert the SIM card in the connector until you feel it click, then let go and the SIM is locked to the connector. To remove the SIM card, depress the SIM in the connector slot again until you feel the same click and let it go; the SIM connector should eject part way out of the connector. The SIM card can then be grabbed and removed. Secure the Micro-SIM cover with a screw, use a number 1 Philips screwdriver to secure the screw on the Micro-SIM cover. The recommended torque is 2.8 - 3.8 inch LBF.

 **Note**

We recommend using industrial-grade SIM cards.

4. You have now successfully inserted the Micro-SIM cards into the Cellular pluggable module. The marking on the Micro-SIM door should align with Micro-SIM 0 on the pluggable module with the arrow pointing upward.

Figure 87: Insert the Micro-SIM cards

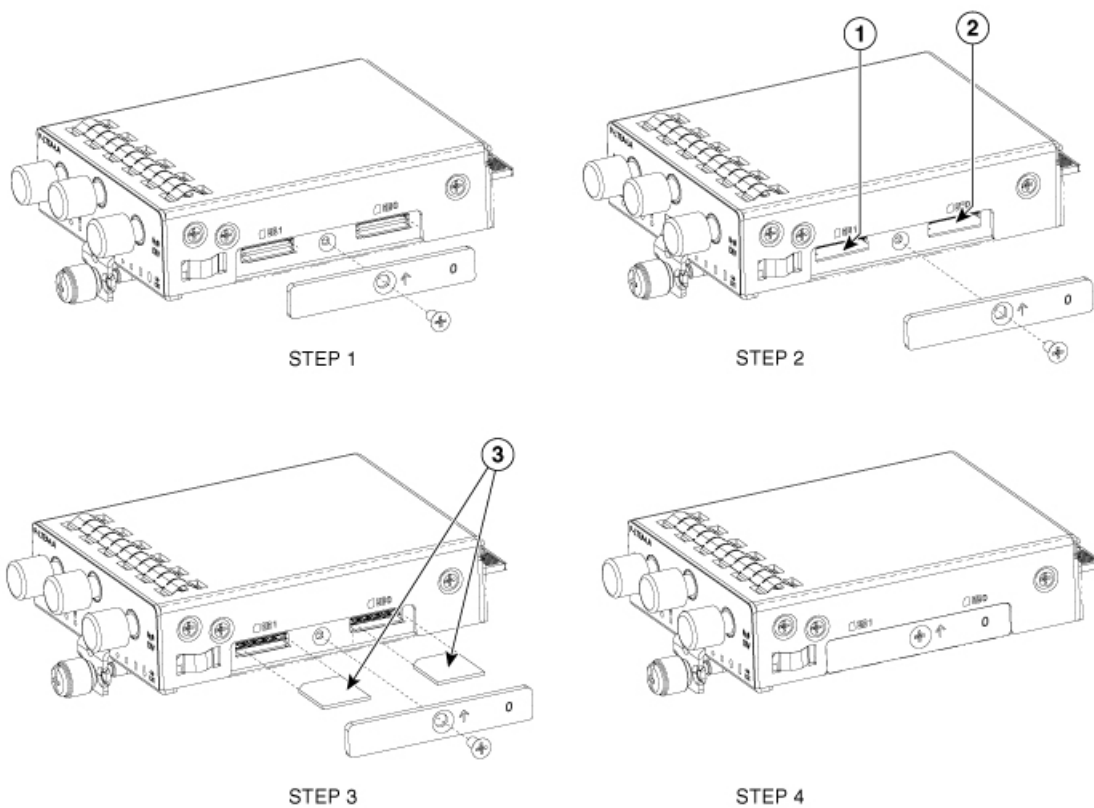

355577

LED behaviors

Explains LED behavior patterns for devices, describing indicators for operational status, troubleshooting, and activity, enabling effective visual monitoring and issue identification.

This table lists the LED indicators and their behavior. The LEDs provide a visual indication of the status and the currently selected services.

LED indicators

LED	Color	Function
EN	Green, Yellow	Enable LED <ul style="list-style-type: none"> Off: Cellular module power is off Yellow: Module power is not functioning correctly Green: Module power is on
SIM0	Green, Yellow	SIM0 LED <ul style="list-style-type: none"> Off: SIM0 is not installed Yellow: SIM0 is installed, but not active Green: SIM0 installed and active Green Blink: Cellular data activity

LED	Color	Function
SIM1	Green, Yellow	<p>SIM1 LED</p> <ul style="list-style-type: none"> • Off: SIM1 is not installed • Yellow: SIM1 is installed, but not active • Green: SIM1 installed and active • Green Blink: Cellular data activity
GPS	Green, Yellow	<p>GPS LED</p> <ul style="list-style-type: none"> • Off: GPS is not configured • Yellow: Software is defined • Green: GPS is configured • Green Blink: GPS is functional
Service	Green, Yellow, Blue	<p>Service indication LED (applicable for P-5GS6-R16SA-GL)</p> <ul style="list-style-type: none"> • Yellow: 3G • Green: 4G LTE • Blue: 5G

LED	Color	Function
RSSI	Green, Yellow	<p>RSSI LED (applicable for P-LTEA7-NA, P-LTEA7-JP, P-LTEA7-EAL)</p> <ul style="list-style-type: none"> Green: 4G, LTE Yellow: 3G <p>RSSI 0</p> <ul style="list-style-type: none"> Yellow: Very bad signal, 3G Green: Very bad signal, 4G <p>RSSI 1</p> <ul style="list-style-type: none"> Yellow: Bad signal, 3G Green: Bad signal, 4G <p>RSSI 2</p> <ul style="list-style-type: none"> Yellow: Good signal, 3G Green: Good signal, 4G <p>RSSI 3</p> <ul style="list-style-type: none"> Yellow: Best signal, 3G Green: Best signal, 4G

Install a Nano-SIM card into the router

Provides instructions for installing a Nano-SIM card into the router, covering proper placement and integration to enable device connectivity and functionality.

This section describes how to install a nano-SIM card into embedded cellular systems. Install a nano-SIM card into the router using these instructions:

1. Press down on the top of the SIM slot cover and pull it away from the router until the top of the cover is free from the chassis.

Figure 88: Removing the SIM Slot Cover

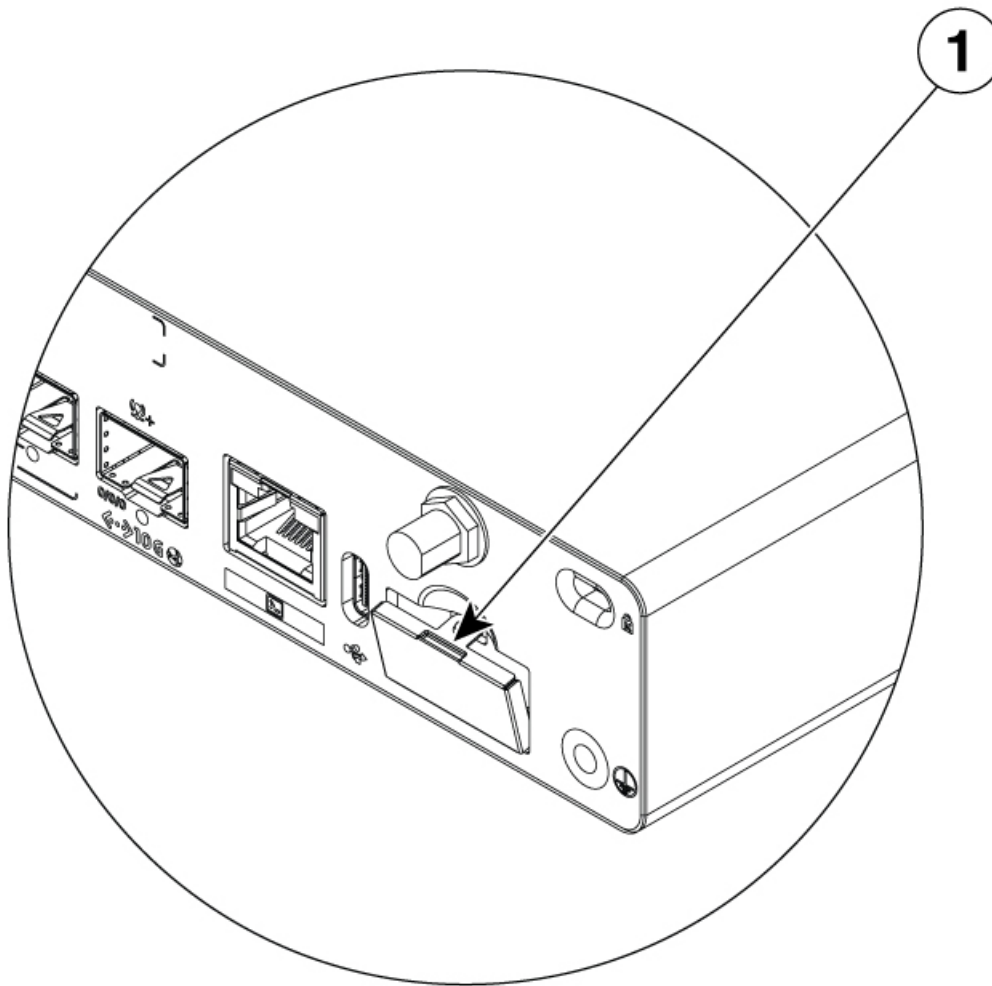

1 SIM Slot Cover

 **Note**

You may use a flat-head screwdriver to press down on the cover; however, ensure the screwdriver does not protrude into the router.

2. Remove the SIM slot cover from the chassis.

Figure 89: Nano-SIM Slot and Component Identification

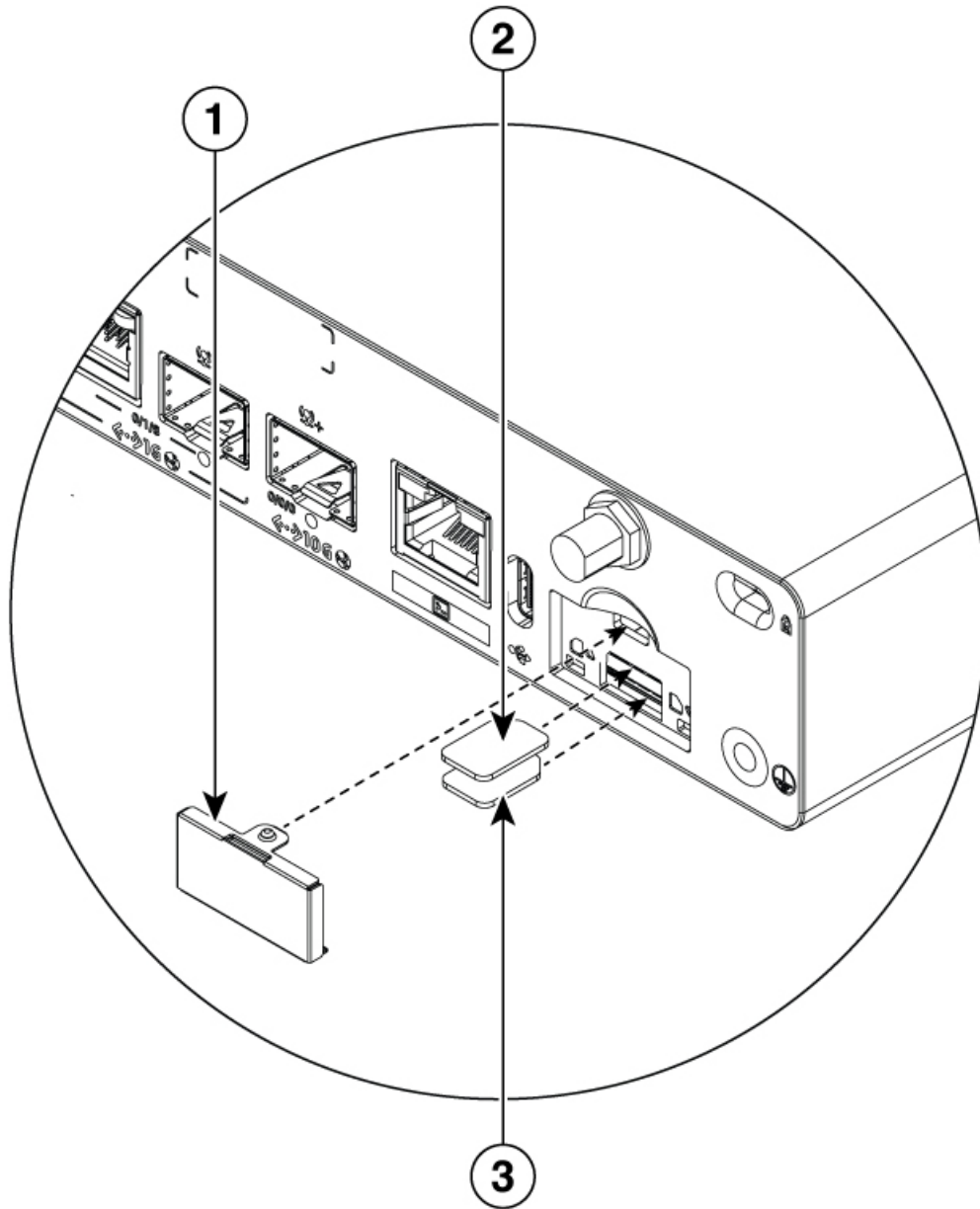

- 1 SIM Slot Cover
- 2 Nano SIM 1
- 3 Nano SIM 0

 **Caution**

Do not touch any part of the exposed printed circuit board (PCB) area while the nano-SIM cover is removed.

 **Note**

Ensure the nano-SIM cards are inserted properly into the slot connector and are not wedged between the slot connector and the chassis opening, where they could be inserted incorrectly. Incorrect insertion may cause damage to the board and/or the nano-SIM card.

3. Insert the nano-SIM cards into their respective slots as indicated by the orientation indicators on the chassis. To install a card, insert the nano-SIM card into the slot until it clicks and locks into the push-push connector. To remove the card, press the SIM card further into the slot until it clicks, then release it. The card will partially eject from the slot.
 - a. SIM 0: Bottom slot
 - b. SIM 1: Top slot

Figure 90: SIM Slot and Orientation Indicators

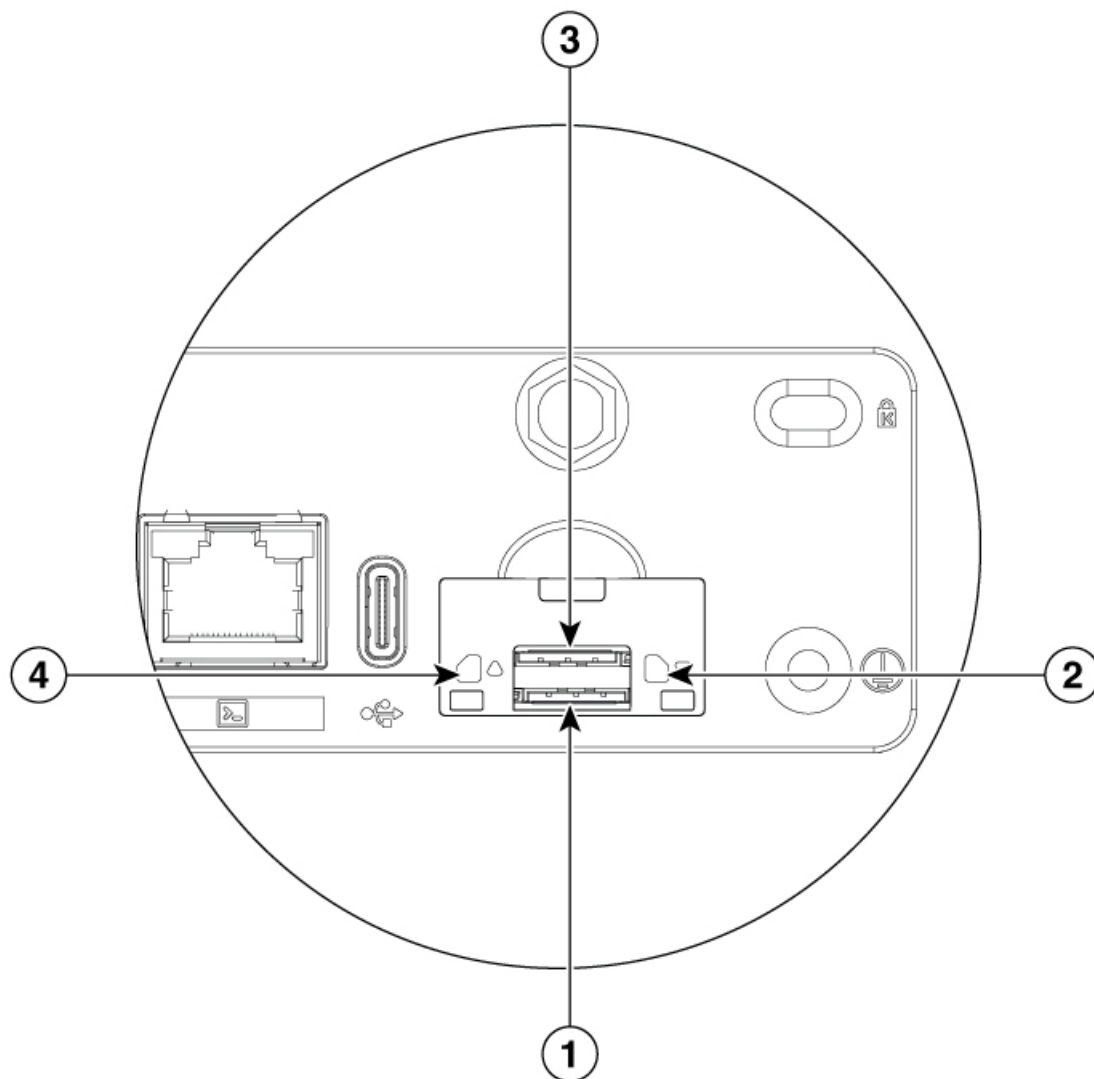

- | | |
|---|----------------------------------|
| 1 | Nano SIM slot 0 |
| 2 | Nano SIM 0 orientation indicator |
| 3 | Nano SIM slot 1 |
| 4 | Nano SIM 1 orientation indicator |

It is recommended to use industrial-grade SIM cards for these routers.

4. Install the SIM slot cover by aligning the bottom securing tabs with the holes in the chassis. Then, press the top of the cover into the snap feature in the chassis.

The nano-SIM card is installed, and the router is ready for operation.

Removal of SFP-10G-ONT20-I XGSPON optical module

Outlines the process for removing the SFP-10G-ONT20-I XGSPON optical module, detailing safe extraction steps to facilitate maintenance and replacement of optical components.

This section explains how to remove the SFP-10G-ONT20-I XGSPON optical module. Removing the module properly prevents damage to the module or the router.

The instructions apply to these models:

- C8130-VAI-G2
- C8130-VAP-G2
- C8151-CVAI-G2
- C8151-CVAP-G2

Follow these steps to remove the SFP-10G-ONT20-I XGSPON optical module from the supported routers:

1. Support the module from the bottom. Release the bail downward using your thumb and index finger.

Figure 91: Hand Position for SFP-10G-ONT20-I Optical Removal

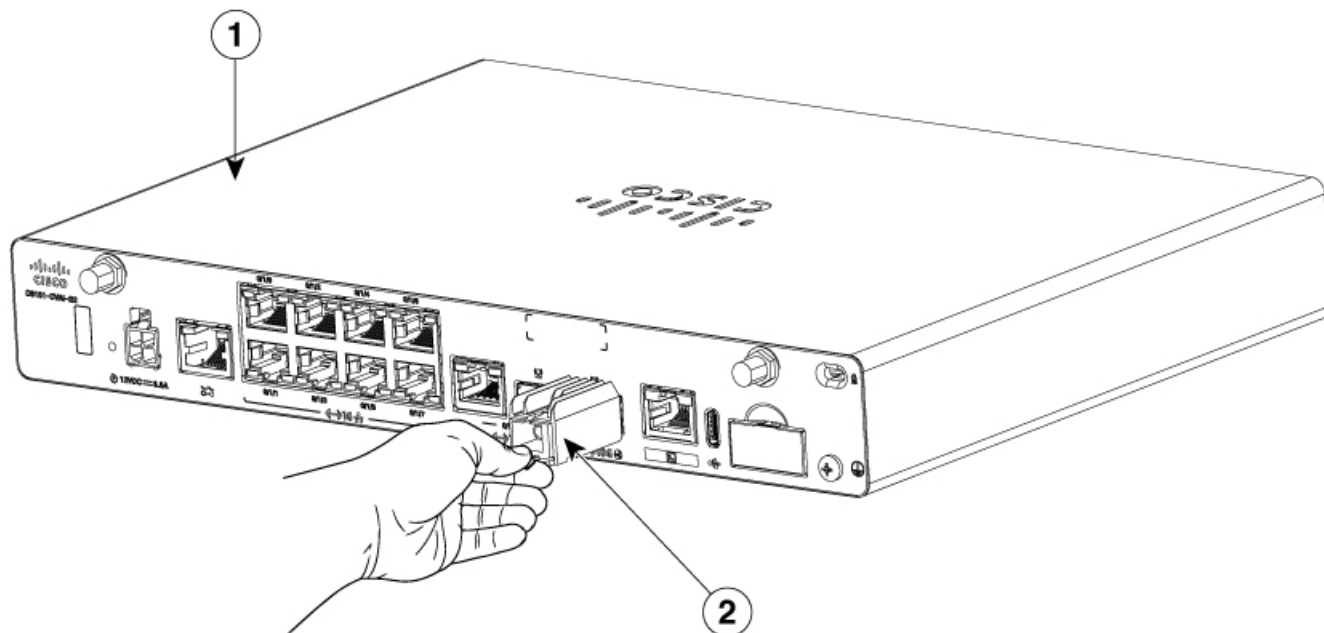

- | | |
|---|----------------|
| 1 | Router |
| 2 | Optical Module |

2. When the module is released from the cage, slide it straight out of the router.

Figure 92: Removal Position of SFP-10G-ONT20-I

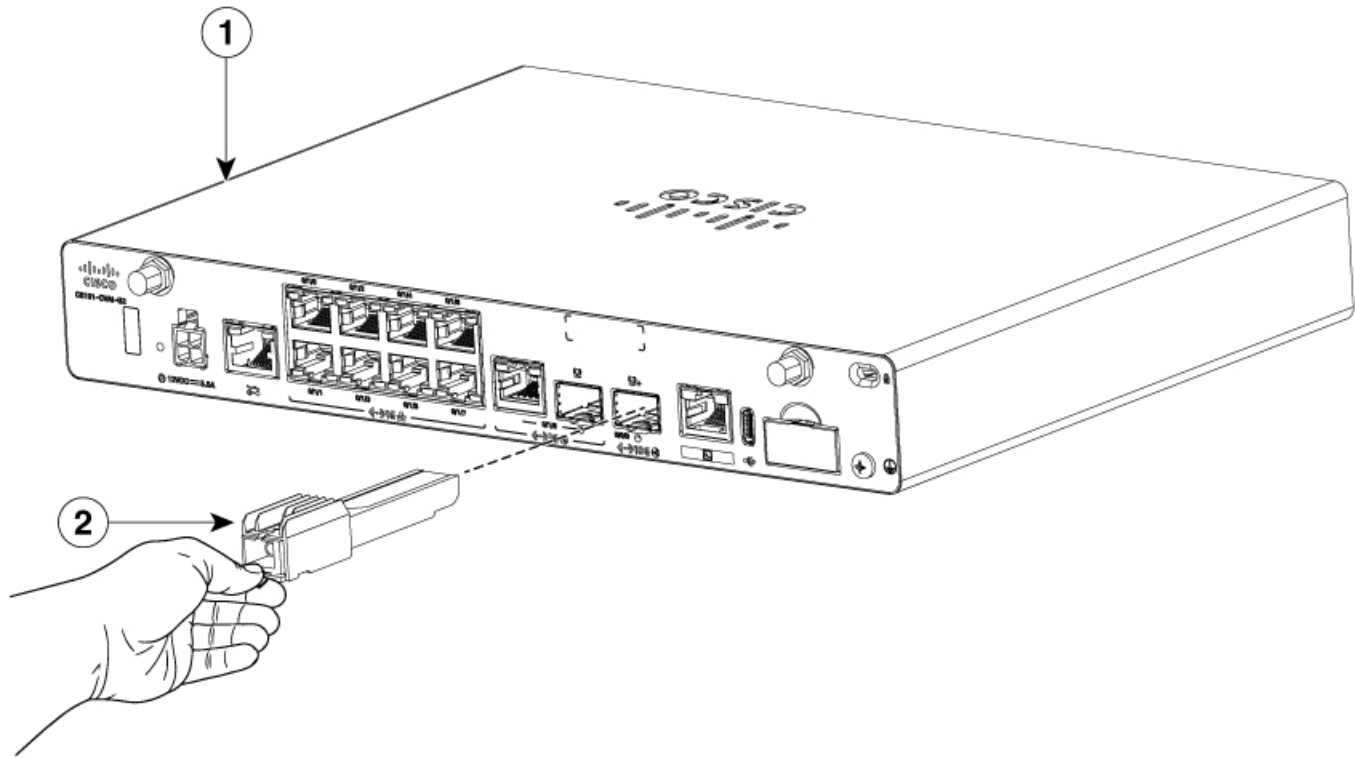

1

Router

2

Optical Module

The optical module is removed from the router.

