



Secure Overlay and Single IP Configuration

- [Secure Overlay, on page 1](#)
- [Single Public IP Address and Secure Overlay, on page 11](#)
- [Single IP Address Without Secure Overlay, on page 16](#)

Secure Overlay



Note The Secure Overlay feature will be deprecated and its last supported release is Cisco NFVIS Release 4.18.1. For future releases, this feature will no longer be supported.

An overlay is a virtualized network layer on top of the physical network with the support of its infrastructure to provide additional security to the network. IPSec is a framework with protocols and algorithms to provide secured data transmission over unprotected or untrusted networks. IPSec secure tunnel is created between two networks to ensure virtual private network communication.

Secure overlay in NFVIS allows IPSec tunnel establishment between NFVIS supporting the vBranch platform and a VPN server and allows the orchestrator to manage NFVIS over the IPSec tunnel.

Supported Features on Secure Overlay

The following features are supported on NFVIS 3.10.x and later releases:

- IPSec IKEv2
- IPv4
- Authentication:
 - Pre-shared-key authentication
 - Introduced in NFVIS 3.12.3 release - EAP authentication
- IKE cipher:
 - aes128-sha1-mopd1536
 - Introduced in NFVIS 3.12.3 release - aes256-sha512-modp2048
 - Introduced in NFVIS 3.12.3 release - aes256-sha512-modp4096

- ESP cipher:
 - aes128-sha1
 - Introduced in NFVIS 3.12.3 release - aes256-sha512
 - Introduced in NFVIS 4.2.1 release - aes256-sha512-modp2048
 - Introduced in NFVIS 4.2.1 release - aes256-sha512-modp4096
 - Introduced in NFVIS 4.4.1 release - aes128-sha1-modp1536, aes256-sha1-modp2048, and aes256-sha256-modp2048
- Local system IP address:
 - Unique tunnel IP address for each NFVIS system.
 - Introduced in NFVIS 3.11.1 release - Internal management network bridge (int-mgmt-net-br) gateway IP address is allowed to be used as local system IP address. In this case, the local system IP bridge must be set to internal management network (int-mgmt-net).
 - Introduced in NFVIS 4.4.1 release - local system IP address can be learnt through IPSec negotiation when local system IP address is not configured.
- Local system IP subnet:
 - local system IP subnet prefix.
 - Introduced in NFVIS 4.4.1 release - local system IP address and subnet can be learnt through IPSec negotiation. In this case local system IP subnet should not be configured.
- Local bridge for NFVIS reaching out to remote VPN server:
 - wan-br by default
 - wan2-br
- Local bridge and Dual local bridge:

Introduced in NFVIS 3.12.1 release - Secure overlay is support on NFVIS Dual WAN feature. DHCP client toggles between wan and wan2 to request for an IP address. When IP address and default gateway are obtained from an interface with DHCP configuration, the toggling stops. If dual-local-bridge is configured, to start overlay, NFVIS selects the interface between local-bridge and dual-local-bridge, in the following order:

 - Interface with DHCP configuration.
 - Interface having static IP address.
 - If both interfaces have static IP address, local-bridge interface.
- Local identity:
 - IP address or FQDN
 - Introduced in NFVIS 3.12.3 release - email domain
- Remote identity:

- IP address or FQDN
- Introduced in NFVIS 3.12.3 release - Distinguish Name
- Introduced in NFVIS 3.12.3 release - email domain
- Introduced in NFVIS 4.4.1 release - Active-Standby headend VPN responder scenario is supported. You can configure a list of Remote IDs, each of which is corresponding to one remote VPN responder.
- Introduced in NFVIS 4.5.1 release - Remote ID configuration using EAP authentication is simplified. If the added security using a distinguished name is not required when using EAP authentication, then an FQDN can be configured on NFVIS to simplify the remote ID configuration and reduce authentication complexity.

- Remote Interface IP address:
 - IP address
 - Introduced in NFVIS 4.4.1 release - FQDN
 - For the FQDN, DNS server has to be configured in system settings or learned through DHCP.

- Remote system IP address:
 - IP address
 - Introduced in NFVIS 4.4.1 release - Active-Standby headend VPN responder scenarios is supported. You can configure a list of Remote system IP addresses, each of which is corresponding to a tunnel IP address on a remote VPN responder.
 - Introduced in NFVIS 4.5.1 release - Remote system IP address can be learned from the remote VPN responder. To do so, leave the **remote-system-ip-addr** field out of the secure overlay configuration entirely

- Remote system IP Subnet:
 - User can specify IP subnet prefix.
 - Introduced in NFVIS 4.1.1 release - User can specify 0.0.0.0/0.
 - Default route is set to Secure Overlay tunnel
 - Following routes bypass the tunnel:
 - If PNP server IP address is discovered before Secure Overlay is configured
 - If DNS server IP address is set before Secure Overlay is configured.
 - Any NFVIS local static route
 - Any route added by user using **system routes route** command
 - Introduced in NFVIS 4.4.1 release - Active-Standby headend VPN responder scenario is supported. You can configure a list of Remote system IP subnets, each of which corresponds to a tunnel IP address on a remote VPN responder.

- BGP Neighbor Name:

```

local-system-ip-addr 192.0.2.1
local-system-ip-bridge int-mgmt-net
local-id mail@gmail.com
remote-interface-ip-addr nfvisoverlay.example.com
remote-system-ip-addr [ 192.0.2.111 192.0.2.112 ]
psk local-psk Cisco1234Admin
psk remote-psk Cisco1234Admin
!
```

```

configure terminal
secure-overlay myconn
local-system-ip-addr 192.0.2.2
local-system-ip-subnet 192.0.2.0/24
local-system-ip-bridge int-mgmt-net
local-id AxxxY@example.com
remote-interface-ip-addr C****d.example.com
remote-system-ip-addr [ 192.0.2.113 166.34.121.112 ]
remote-system-ip-subnet [ 192.0.2.112/32 192.0.2.112/32 ]
remote-id [
CN=vbranch,unstructuredAddress=10.30.1.114,unstructuredName=csr-vpn-srvr-02.example.com
CN=vbranch,unstructuredAddress=10.30.1.153,unstructuredName=csr-vpn-srvr-03.example.com ]
ike-cipher [ aes256-sha512-modp2048 ]
esp-cipher [ aes256-sha512-modp2048 ]
eap username admin
eap password Cisco123#
eap cacert intdatastore:uploads/ca.pem
!
```

To get the secure overlay state:

```

nfvis# show secure-overlay

ACTIVE          ACTIVE

ACTIVE          SELECTED LOCAL      REMOTE      ACTIVE REMOTE

LOCAL  STATE  LOCAL  SYSTEM IP  INTERFACE  SYSTEM IP  ACTIVE
REMOTE

NAME  STATE  BRIDGE  DETAILS  BRIDGE  ADDR      IP ADDR  ADDR      SYSTEM
IP SUBNET  ACTIVE  REMOTE  ID

-----
myconn up    wan-br -    wan-br  192.0.2.2  10.30.1.153  192.0.2.112  192.0.2.112/32
"CN=vbranch,unstructuredAddress=10.30.1.153,unstructuredName=csr-vpn-srvr-03.example.com"

nfvis#
```

Examples for Configuring Secure Overlay



Note Secure overlay configuration on NFVIS must match with VPN configuration on the VPN server. The secure overlay tunnel will not be established successfully if the configurations do not match.

Secure Overlay over WAN with pre-shared-key and FQDN remote-id

```
<config xmlns="http://tail-f.com/ns/config/1.0">
```

```

<secure-overlays xmlns="http://www.cisco.com/nfvis/secure-overlay">
  <secure-overlay>
    <name>myconn</name>
    <local-system-ip-addr>192.0.2.2</local-system-ip-addr>
    <local-system-ip-subnet>192.0.2.0/24</local-system-ip-subnet>
    <local-system-ip-bridge>int-mgmt-net</local-system-ip-bridge>
    <local-id>branch1@vpntest.com</local-id>
    <remote-interface-ip-addr>csrhead.cisco.com</remote-interface-ip-addr>
    <remote-system-ip-addr>192.0.2.112</remote-system-ip-addr>
    <remote-system-ip-addr>192.0.2.112/32</remote-system-ip-addr>
    <remote-system-ip-subnet>192.0.2.112/32</remote-system-ip-subnet>
    <remote-system-ip-subnet>192.0.2.112/32</remote-system-ip-subnet>

    <remote-id>CN=vbranch,unstructuredAddress=10.30.1.114,unstructuredName=csr-vpn-srvr-02.cisco.com</remote-id>

    <remote-id>CN=vbranch,unstructuredAddress=10.30.1.153,unstructuredName=csr-vpn-srvr-03.cisco.com</remote-id>

    <ike-cipher>aes256-sha512-modp2048</ike-cipher>
    <esp-cipher>aes256-sha512-modp2048</esp-cipher>
    <eap>
      <username>admin</username>
      <password>$7$2Eh54XQvwwTicwX+lEuMWjuA7q+sfaa</password>
      <cacert>intdatastore:uploads/ca.pem</cacert>
    </eap>
  </secure-overlay>
</secure-overlays>
</config>

```

VPN configuration on VPN server:

```

aaa new-model

!

aaa group server radius radius-group

  server-private 10.30.1.234 auth-port 1812 acct-port 1813 key Cisco123#

  ip vrf forwarding public-vrf

  ip radius source-interface GigabitEthernet2

!

aaa authentication login default group radius-group local

aaa authentication login ucpe-authen group radius-group

aaa authorization console

aaa authorization exec default local

aaa authorization network default local

!

aaa session-id common

!

crypto pki trustpoint TP-self-signed-2641177237
  enrollment selfsigned

```

```
subject-name cn=IOS-Self-Signed-Certificate-2641177237
revocation-check none
rsa-keypair TP-self-signed-2641177237
crypto pki trustpoint SLA-TrustPoint
  revocation-check crl
crypto pki trustpoint router
  enrollment url http://10.30.1.153:80
  ip-address 10.30.1.114
  subject-name CN=vbranch
  vrf public-vrf
  revocation-check crl
  rsa-keypair router
  auto-enroll regenerate
  hash sha512

crypto ikev2 authorization policy uCPE-author-pol
  pool uCPE-pool1
  dns 192.0.2.103 192.0.2.90
  pfs
  route set interface Loopback1001
no crypto ikev2 authorization policy default

crypto ikev2 proposal uCPE-proposal
  encryption aes-cbc-256
  integrity sha512
  group 16 14
no crypto ikev2 policy default

crypto ikev2 policy uCPE-policy
  match fvrfr public-vrf
  proposal uCPE-proposal

crypto ikev2 profile uCPE-profile
  description uCPE profile
  match fvrfr public-vrf
  match identity remote email domain vpntest.com
  identity local dn
  authentication local rsa-sig
  authentication remote eap query-identity
  pki trustpoint router
  dpd 60 2 on-demand
  aaa authentication eap ucpe-authen
  aaa authorization group eap list default uCPE-author-pol
  virtual-template 1 mode auto

crypto ipsec transform-set tset_aes_256_sha512 esp-aes 256 esp-sha512-hmac
  mode tunnel
crypto ipsec df-bit clear
no crypto ipsec profile default
crypto ipsec profile uCPE-ips-prof
  set security-association lifetime seconds 28800
  set security-association idle-time 1800
  set transform-set tset_aes_256_sha512
  set pfs group14
  set ikev2-profile uCPE-profile
crypto call admission limit ike in-negotiation-sa 30

ip radius source-interface GigabitEthernet2
```

```
route set interface Loopback1001
interface Loopback1
  ip vrf forwarding private-vrf
  ip address 10.90.90.1 255.255.255.255
interface Loopback2
  ip vrf forwarding private-vrf
  ip address 10.91.91.1 255.255.255.0
interface Loopback3
  ip vrf forwarding private-vrf
  ip address 10.90.90.201 255.255.255.128
interface Loopback1001
  description MNSO Interface and Tunnel Loopback
  ip vrf forwarding private-vrf
  ip address 192.0.2.114 255.255.255.255
interface GigabitEthernet1
  ip vrf forwarding private-vrf
  ip address 10.92.92.1 255.255.255.0
  negotiation auto
  no mop enabled
  no mop sysid
interface GigabitEthernet2
  ip vrf forwarding public-vrf
  ip address 10.30.1.114 255.255.255.0
  negotiation auto
  no mop enabled
  no mop sysid
interface GigabitEthernet3
  ip vrf forwarding private-vrf
  ip address 10.91.91.1 255.255.255.0
  shutdown
  negotiation auto
  no mop enabled
```

```

no mop sysid

interface Virtual-Templatel type tunnel

ip vrf forwarding private-vrf

ip unnumbered Loopback1001

ip mtu 1400

ip tcp adjust-mss 1380

tunnel vrf public-vrf

tunnel protection ipsec profile uCPE-ips-prof

ip radius source-interface GigabitEthernet2

```

Internal management network bridge IP address as local system IP address



Note NFVIS internal management network has gateway IP address 10.12.12.1.

```

<secure-overlay>
  <name>mgmthub</name>
  <local-bridge>wan-br</local-bridge>
  <local-system-ip-addr>10.12.12.1</local-system-ip-addr>
  <local-system-ip-bridge>int-mgmt-net</local-system-ip-bridge>
  <remote-interface-ip-addr>10.85.189.36</remote-interface-ip-addr>
  <remote-system-ip-addr>10.19.18.251</remote-system-ip-addr>
  <remote-id>mgmt-hub.cloudvpn.com</remote-id>
  <psk>
    <local-psk>Cisco1234Admin</local-psk>
    <remote-psk>Cisco1234Admin</remote-psk>
  </psk>
</secure-overlay>

```

dual-local-bridge and int-mgmt-net-br IP as local system IP

```

<secure-overlay>
  <name>mgmthub</name>
  <local-bridge>wan-br</local-bridge>
  <dual-local-bridge>wan2-br</dual-local-bridge>
  <local-system-ip-addr>10.12.12.1</local-system-ip-addr>
  <local-system-ip-bridge>int-mgmt-net</local-system-ip-bridge>
  <remote-interface-ip-addr>10.85.189.36</remote-interface-ip-addr>
  <remote-system-ip-addr>10.19.18.251</remote-system-ip-addr>
  <remote-id>mgmt-hub.cloudvpn.com</remote-id>
  <psk>
    <local-psk>Cisco1234Admin</local-psk>
    <remote-psk>Cisco1234Admin</remote-psk>
  </psk>
</secure-overlay>

```

EAP authentication

```

<secure-overlay>
  <name>mgmthub</name>
  <local-bridge>wan-br</local-bridge>

```

```

<local-system-ip-addr>10.12.12.1</local-system-ip-addr>
<local-system-ip-bridge>int-mgmt-net</local-system-ip-bridge>
<local-id>branch101@example.com</local-id>
<remote-interface-ip-addr> 192.0.2.75</remote-interface-ip-addr>
<remote-system-ip-addr> 192.168.1.90</remote-system-ip-addr>
<remote-id>CN=vbranch, unstructuredAddress=192.0.2.75,
unstructuredName=Headend.headendvpn</remote-id>
<ike-cipher>aes256-sha512-modp2048</ike-cipher>
<esp-cipher>aes256-sha51</esp-cipher>
<eap>
  <username>admin</username>
  <password>Cisco123#</password>
  <cacert>https://cert/csr.pem</cacert>
</eap>
</secure-overlay>

```

The following is an example of the VPN configuration on VPN server:

```

aaa group server radius radius-group
  server-private 172.19.160.190 auth-port 1812 acct-port 1813 key Cisco123#
  ip radius source-interface GigabitEthernet

aaa authentication login default group radius-group
aaa authentication login ucpe-authen group radius-group

ip domain name headendvpn

crypto pki server ca-server
  database level names
  no database archive
  hash sha512
  lifetime certificate 3650
  lifetime ca-certificate 7305 23 59
  auto-rollover 365
  eku server-auth client-auth
  database url flash:ca

crypto pki trustpoint ca-server
  revocation-check crl
  rsakeypair ca-server

crypto pki trustpoint router
  enrollment url http://192.0.2.75:80
  ip-address 192.0.2.75
  subject-name CN=vbranch
  revocation-check crl
  rsakeypair router
  auto-enroll regenerate
  hash sha512

crypto ikev2 authorization policy uCPE-athor-pol
  pfs
  route set interface

no crypto ikev2 authorization policy default

crypto ikev2 proposal uCPE-proposal
  encryption aes-cbc-256
  integrity sha512
  group 16 14

no crypto ikev2 policy default

```

```

crypto ikev2 policy uCPE-policy
 match address local 192.0.2.75
 proposal uCPE-proposal
crypto ikev2 profile uCPE-profile
 description uCPE profile
 match identity remote email domain cisco.com
 identity local dn
 authentication local rsa-sig
 authentication remote eap query-identity
 pki trustpoint router
 dpd 60 2 on-demand
 aaa authentication eap ucpe-authen
 aaa authorization group eap list default uCPE-athor-pol
 virtual-template 1 mode auto

crypto ipsec transform-set tset_aes_256_sha512 esp-aes 256 esp-sha512-hmac
 mode tunnel

crypto ipsec profile uCPE-ips-prof
 set security-association lifetime seconds 28800
 set security-association idle-time 1800
 set transform-set tset_aes_256_sha512
 set pfs group16
 set ikev2-profile uCPE-profile

interface Loopback1
 ip address 192.168.254.1 255.255.255.0

interface GigabitEthernet1
 ip address 192.0.2.75 255.255.255.0
 negotiation auto
 no mop enabled
 no mop sysid

interface GigabitEthernet2
 ip address 192.168.1.90 255.255.255.0
 negotiation auto
 no mop enabled
 no mop sysid

interface Virtual-Template1 type tunnel
 description uCPE virt template
 ip unnumbered Loopback1
 ip mtu 1400
 ip tcp adjust-mss 1360
 tunnel source GigabitEthernet1
 tunnel mode ipsec ipv4
 tunnel protection ipsec profile uCPE-ips-prof

```

Single Public IP Address and Secure Overlay

Single Public IP Address

In a virtual branch deployment, two public IP addresses are needed for each branch site, one for the NFVIS hypervisor and the other one for the WAN router. In Single Public IP Address feature on NFVIS, one public IP address assigned to a branch site, is seamlessly shared between the NFVIS hypervisor and the guest VM deployed on NFVIS. This feature ensures that the branch site is reachable even if the guest router is in failure state.

NFVIS reclaims the WAN IP address if the guest router has:

- Deployment failure.
- Error state.
- Stopped.
- Undeployed.

NFVIS releases the WAN IP address if the guest router has:

- Deployed.
- Started.

To create a single-ip-mode:

```
configure terminal
single-ip-mode vm-name <vm_deploy_name>.<vm_group_name>
commit
```

Use the **show vm_lifecycle deployments all | include Name** command to find out the Deployment Name and VM Group Name.

To get the state of single-ip-mode use the **show single-ip-mode** command.

Single Public IP Address with Secure Overlay

Secure overlay tunnel is established automatically when IP address is moves back and forth between NFVIS and the guest VM. The orchestrator can always reach NFVIS through the system IP address which does not change during the transitioning of the single public IP address.

Figure 1: Example of Setting IPSec Tunnel in Single IP mode

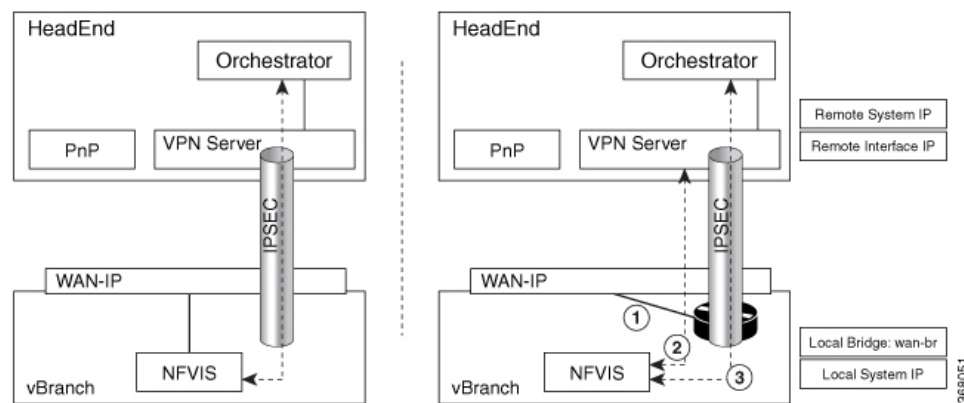

After secure overlay over WAN is established, the orchestrator sends requests to configure single IP mode and deploy the guest router that takes the public IP address.

1. NFVIS deploys the VM with specified bootstrap and Day-0 configuration. NFVIS takes down the current IPSec tunnel and releases the public IP address.
2. The VM takes the public IP address when it is in active state. NFVIS sets up the IPSec tunnel again with the remote management hub.

- After the IPsec tunnel is up, the orchestrator can connect to NFVIS through its system IP address and manage NFVIS over the IPsec tunnel.

In single IP mode, NFVIS monitors the guest VM taking the public IP address. NFVIS takes WAN IP address back when the guest VM is:

- In error state.
- Stopped through vmAction.
- Undeployed.

Figure 2: Example of NFVIS Handling Failure

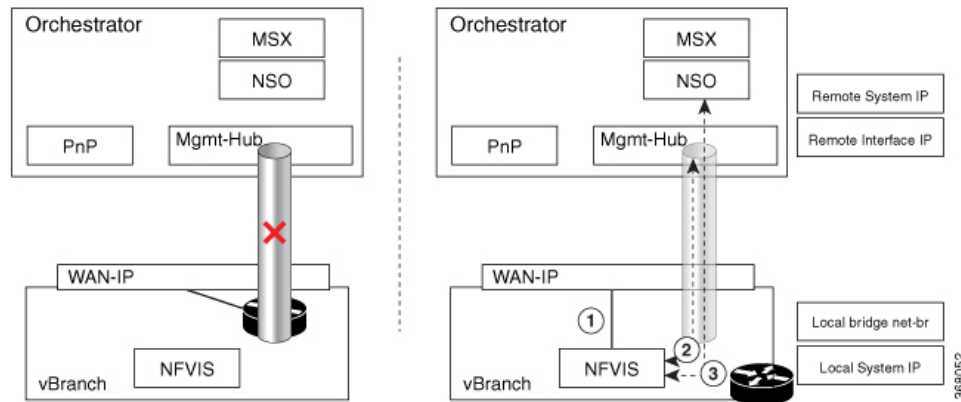

- NFVIS takes WAN IP address.
- NFVIS sets up IPsec tunnel to the management hub.
- When IPsec tunnel is up, the VPN server can connect to NFVIS through its system IP address and manage NFVIS over the IPsec tunnel.

Each NFVIS has its int-mgmt-net and subnet associated to the IP address pool. The following is an example to setup the IP address pool before deploying VM:

```
no vm_lifecycle networks network int-mgmt-net
commit
vm_lifecycle networks network int-mgmt-net
subnet int-mgmt-net-subnet address 10.12.12.0
netmask 255.255.255.0
gateway 10.12.12.1
dhcp false
ipversion ipv4
commit
```

Single IP Monitoring External Gateway

Before NFVIS 4.8, single IP monitors the external gateway using a ping, every 2 minutes, by default. Starting from NFVIS 4.8, single IP monitors the external gateway only if you configure the `wan-monitor-interval` command. The monitor interval can range from 2 minutes to 60 minutes. If the `wan-monitor-interval` command is deleted, single IP stops monitoring the external gateway.

To configure the external gateway monitor interval:

```

nfvis(config)# single-ip-mode wan-monitor-interval ?
Description: Monitor interval in minute, value range from 2-60.
Possible completions:
  <short, 2 .. 60>

```

Guest VM Taking Public IP Address

Guest VM must be deployed as a monitored VM which has two interfaces:

- Interface facing public with the public IP address.
- Interface on int-mgmt-net-br for traffic flow with NFVIS.

The guest VM has routing function to route traffic between the two interfaces and Network address translation (NAT) enabled. NFVIS reaches remote through int-mgmt-net-br to the guest VM.

The int-mgmt-net-br address pool and gateway IP address must be unique on each NFVIS. If secure overlay is configured, single IP mode is setup when VM is active and int-mgmt-net-br is used as a local-bridge.

Single IP Address and DHCP

NFVIS single-ip-mode supports the public IP address acquired through DHCP by leveraging on the lease timer configuration on DHCP server. The guest VM with Day-0 configuration gets the IP address through DHCP when NFVIS client sends release message to DHCP server.

To handle failure, NFVIS:

- stops the VM, to ensure the VM dhclient does not send DHCP renew to DHCP server
- switches back to WAN and its dhclient sends DHCP renew message to DHCP server
- gets the same IP address from DHCP server when VM's lease time expires.

ISRV Bootstrap and Day-0 Configuration

In single-ip-mode, NFVIS reaches to the guest router and takes its IP address. Traffic must be allowed between ISRV gigabit ethernet interface 1 connected to NFVIS int-mgmt-net-br and gigabit ethernet interface 2 connected to public side having the public IP address.

The following is an example based on ISRV 16.09.01a that shows how to configure the guest router to route the traffic:

```

<?xml version="1.0" encoding="UTF-8"?>
<Environment
xmlns:oe="http://schemas.dmtf.org/ovf/environment/1">
  <PropertySection>
    <Property oe:key="com.cisco.csr1000v.config-version.1" oe:value="1.0"/>
    <Property oe:key="com.cisco.csr1000v.enable-ssh-server.1" oe:value="True"/>
    <Property oe:key="com.cisco.csr1000v.login-username.1" oe:value="${SSH_USERNAME}"/>
    <Property oe:key="com.cisco.csr1000v.login-password.1" oe:value="${SSH_PASSWORD}"/>
    <Property oe:key="com.cisco.csr1000v.mgmt-interface.1" oe:value="GigabitEthernet1"/>
    !!!GigabitEthernet1-nicid(0)-int-mgmt-interface-don't change ip address or don't shutdown
    <Property oe:key="com.cisco.csr1000v.mgmt-ipv4-addr.1"
oe:value="${NICID_0_IP_ADDRESS}/24"/>
    <Property oe:key="com.cisco.csr1000v.mgmt-ipv4-network.1" oe:value=""/>
    <Property oe:key="com.cisco.csr1000v.license.1" oe:value="${TECH_PACKAGE}"/>
    <Property oe:key="com.cisco.csr1000v.ios-config-0001" oe:value="vrf definition
Mgmt-intf"/>

```

```

    <Property oe:key="com.cisco.csr1000v.ios-config-0002" oe:value="address-family ipv4"/>
    <Property oe:key="com.cisco.csr1000v.ios-config-0003" oe:value="exit-address-family"/>
    <Property oe:key="com.cisco.csr1000v.ios-config-0004" oe:value="address-family ipv6"/>
    <Property oe:key="com.cisco.csr1000v.ios-config-0005" oe:value="exit-address-family"/>
    <Property oe:key="com.cisco.csr1000v.ios-config-0006" oe:value="exit"/>
    <Property oe:key="com.cisco.csr1000v.ios-config-0007" oe:value="interface
GigabitEthernet1"/>
    <Property oe:key="com.cisco.csr1000v.ios-config-0008" oe:value="ip address
${NICID_0_IP_ADDRESS} ${NICID_0_NETMASK}"/>
    <Property oe:key="com.cisco.csr1000v.ios-config-0009" oe:value="no shut"/>
    <Property oe:key="com.cisco.csr1000v.ios-config-0010" oe:value="exit"/>
  </PropertySection>
</Environment>

```

The following is an example of ISRv day-0 configuration with a static public IP address:

```

interface GigabitEthernet1
ip nat inside
negotiation auto
!
interface GigabitEthernet2
ip address 192.0.2.17 255.255.255.0
ip nat outside
negotiation auto
!
ip nat inside source list NAT interface GigabitEthernet2 overload
ip route 0.0.0.0 0.0.0.0 192.0.2.1
ip route 10.19.18.0 255.255.255.0 10.12.12.1
!
ip access-list standard NAT
permit 10.12.12.0.0.0.0.25

```

The following is an example of ISRv day-0 configuration with DHCP IP address:

```

interface GigabitEthernet1
ip nat inside
negotiation auto
!
interface GigabitEthernet2
ip address dhcp
ip nat outside
negotiation auto
!
ip nat inside source list NAT interface GigabitEthernet2 overload
ip route 10.19.18.0 255.255.255.0 10.12.12.1
!
ip access-list standard NAT
permit 10.12.12.0.0.0.0.25

```

To verify single IP address mode status us the **show single-ip-mode** and **show secure-overlay** command:

```

nfvis#

single-ip-mode state start
single-ip-mode state-details "waiting for VM ROUTER.ROUTER deployment"

nfvis#

single-ip-mode state start
single-ip-mode state-details "VM deployed"
nfvis#

```

```

nfvis# show secure-overlay

NAME      STATE      ACTIVE LOCAL      STATE
          STATE      BRIDGE      DETAILS
-----
mgmthub  up          int-mgmt-net-br  VM alive

```

Single IP and Secure Overlay APIs

Secure Overlay APIs	Secure Overlay Commands
/api/config/single-ip-mode	single-ip-mode
/api/operational/single-ip-mode	

Single IP Address Without Secure Overlay



Note This feature is only supported for WAN bridge in NFVIS 3.10.1 release, and Single-IP works only on the GE0-0 port.

To reach NFVIS when secure overlay is not configured, you must first configure the guest device and manage IP addressing. The rest of the functionality, switching IP address between NFVIS and the guest device is the same as IP address with secure overlay.

Typically you need two IP addresses in each site, one for NFVIS and one for the VM. You can enable the single IP feature to reduce one public IP address. The single public IP address is used by NFVIS after deploying the VM with the single IP feature. After the VM comes up, NFVIS releases the public IP address for the VM to use. NFVIS and the VM have an internal network to communicate with each other. The traffic between NFVIS and an external network will need to go through the new VM and NAT by the new VM.

For single IP without secure overlay feature to work:

- From the **Deploy** page on NFVIS portal select single IP or configure the single IP mode by using the **single-ip-mode router.router** command.
- Provide a bootstrap file for the VM.
- Enable **Monitor** for the VM and the internal network int-mgmt-net between NFVIS and VM is created automatically.

The following example is a sample bootstrapping configuration:

192.0.2.7/24 is the single public IP address that is originally used by NFVIS and later by the VM. 192.0.2.1 is the gateway to the external network and 10.20.0.x is the internal network between NFVIS and the VM. IP address in 10.20.0.x network is used to NAT by the VM: -

```

-----
interface GigabitEthernet1
ip nat inside
negotiation auto
!
interface GigabitEthernet2

```

```
ip address 192.0.2.17 255.255.255.0
ip nat outside
negotiation auto
!
ip nat inside source list NAT interface GigabitEthernet2 overload
ip route 0.0.0.0 0.0.0.0 192.0.2.1
!
ip access-list standard NAT
permit 10.20.0.0 0.0.0.25
-----
```

When the VM is down, NFVIS takes back the single IP address and the external server can communicate with NFVIS directly.

