



## Platform Specific Configurations

**Table 1: Feature History**

Feature Name	Release Information	Description
Datapath Over LTE Cellular Interface on Cisco Catalyst 8200 UCPE	Cisco NFVIS Release 4.16.1	The Datapath Over LTE Cellular Interface feature on the Cisco Catalyst 8200 UCPE facilitates traffic routing through an LTE cellular interface. This feature allows both control connection and virtual machine data traffic to be routed via the cellular interface, providing redundancy and an alternative path for wired connections.
C8300-UCPE Virtual RAID and Supported NIMs Specifications	Cisco NFVIS Release 4.18.1	The C8300-UCPE platform has new functionalities: <ul style="list-style-type: none"> <li>• It introduces C-NIM-8T and C-NIM-4X network interface modules (NIMs).</li> <li>• It supports a software Redundant Array of Independent Disks (RAID) controller, which allows you to create a RAID array using two identical E-SSD-U2N disks (U.2 NVMe drives), configured as either RAID1 or RAID0.</li> </ul>

- [ENCS Switch Configuration, on page 2](#)
- [Configure Additional WAN Transport Connectivity On ENCS Switch Ports, on page 12](#)
- [Configuring vBranch High Availability, on page 17](#)
- [CIMC Secure Overlay Support, on page 29](#)
- [CIMC TACACS Support, on page 30](#)

- [LTE PIM Module on Cisco Catalyst 8200 UCPE, on page 31](#)
- [Datapath Over LTE Cellular Interface on Cisco Catalyst 8200 UCPE, on page 50](#)
- [External Storage for Cisco ENCS 5400 and Cisco Cloud Services Platforms, on page 53](#)
- [Support for 40G Dual Port and Quad-Split NICs on Cisco Cloud Services Platforms, on page 55](#)
- [C8300-UCPE Virtual RAID and Supported NIMs Specifications, on page 58](#)

## ENCS Switch Configuration

Access to the ENCS switch is restricted through Consent Token. Consent Token is a security feature that is used to authenticate the network administrator of an organization to access system shell with mutual consent from the network administrator and Cisco Technical Assistance Centre (Cisco TAC).



### Note

- From the switch console, there is access to debug mode and an advanced debug mode. Credentials of the local user are synchronized to access debug mode. Advanced debug uses unique credentials for each device that allows for additional debugging options for Cisco engineering. To enter either debug mode permission must be granted through Consent Token.
- To configure any parameter on the ENCS switch portal, ensure that you add or remove parameters using separate transactions on the CLI. For example, adding and removing multiple VLANs from the ENCS switch portal is not supported in the same CLI transaction. Add a VLAN first and then remove the VLAN in a separate transaction.

## ENCS Switch Commands

See, [Cisco Enterprise Network Compute System Switch Command Reference](#) for switch commands.

## ENCS Switch APIs

See, [API Reference for Cisco Enterprise Network Function Virtualization Infrastructure Software](#) for switch related APIs.

## ENCS Switch Portal Configuration

### Switch Settings

The **Switch** option from the Cisco Enterprise NFVIS portal allows you to configure STP/RSTP, VLAN on specified ranges, RADIUS based authentication, and port channel load balancing for various switch ports. This section describes how to configure settings on the ENCS switch portal.

SwitchPort	Description	Status	MAC Address	PortType	VLAN	Speed	RXBytes	PktDrop
GigabitEthernet1/0		down	00 a6 ca d6 32 d9	access	1	1000	0	0
GigabitEthernet1/1		down	00 a6 ca d6 32 da	access	1	1000	0	0
GigabitEthernet1/2		down	00 a6 ca d6 32 db	access	1	1000	0	0
GigabitEthernet1/3		down	00 a6 ca d6 32 dc	access	1	1000	0	0
GigabitEthernet1/4		down	00 a6 ca d6 32 dd	access	1	1000	0	0
GigabitEthernet1/5		down	00 a6 ca d6 32 de	access	1	1000	0	0
GigabitEthernet1/6		down	00 a6 ca d6 32 df	access	1	1000	0	0
GigabitEthernet1/7		down	00 a6 ca d6 32 e0	access	1	1000	0	0

366822

POR	IN-UCAS	OUT-UCAS	IN-MCAS	OUT-MCAS	IN-BCAS	OUT-BCAST
T	T	T	T	T	T	
1/0	0	0	0	0	0	0
1/1	0	0	0	0	0	0
1/2	0	0	0	0	0	0
1/3	0	0	0	0	0	0
1/4	0	0	0	0	0	0
1/5	0	0	0	0	0	0
1/6	0	0	0	0	0	0
1/7	0	0	0	0	0	0

366823

You can view the Switch Interface operational data and the statistics parameters in the following table:

**Table 2: Switch Settings Interface**

Parameter	Description	Values
SwitchPort	Specifies the switch interface name.	
Description	Specifies the description of the interface.	
Status	Specifies the status of the interface.	up or down
MAC Address	Specifies the MAC address of the interface.	
PortType	Specifies the mode of the port interface.	Supported types are: <ul style="list-style-type: none"> <li>• access</li> <li>• dot1q-tunnel</li> <li>• private-vlan</li> <li>• trunk</li> </ul>
VLAN	Specifies the VLAN ID.	Range: 1-2349 and 2450-4093

Speed	Specifies the speed of the interface.	Speed: <ul style="list-style-type: none"> <li>• 10 MBPS</li> <li>• 100 MBPS</li> <li>• 1000 MBPS</li> </ul>
RxBytes	Specifies the received data on interface in bytes.	
PktDrop	Specifies the number of packet drops.	
PORT	Specifies the port number.	
IN-UCAST	Specifies the number of incoming unicast packets at the interface.	
OUT-UCAST	Specifies the number of outgoing unicast packets at the interface.	
IN-MCAST	Specifies the number of incoming multicast packets at the interface.	
OUT-MCAST	Specifies the number of outgoing multicast packets at the interface.	
IN-BCAST	Specifies the number of incoming broadcast packets at the interface.	
OUT-BCAST	Specifies the number of outgoing broadcast packets at the interface.	

## Configuring Spanning Tree

Spanning Tree Protocol (STP) is a Layer 2 protocol that runs on bridges and switches. The main purpose of STP is to ensure that you do not create loops when you have redundant paths in your network.

The Spanning Tree option is enabled by default. You can click on **edit** and make the necessary settings or disable Spanning Tree if required.

The screenshot shows a configuration page for Spanning Tree. On the left, there is a sidebar with 'Spanning Tree' selected, and other options like 'dot1x', 'LACP', and 'Vlan'. The main content area displays the following configuration parameters:

- Spanning Tree:** A toggle switch set to 'Enable'.
- Mode:** A dropdown menu set to 'rstp'.
- Forward Time:** A numeric input field set to '15'.
- Hello Time:** A numeric input field set to '2'.
- Max Age:** A numeric input field set to '20'.
- Loopback Guard:** A toggle switch set to 'Disable'.
- Path Cost Method:** A dropdown menu set to 'long'.
- Priority:** A numeric input field set to '32768'.

At the bottom of the configuration area, there is a blue 'Edit' button. On the right side of the page, there is a vertical ID '366824'.

The configuration of spanning tree has the following parameters when it is enabled:

**Table 3: Spanning Tree Parameters**

Parameter	Description	Values
Spanning Tree	Specifies the state of the Spanning Tree.	Enable or Disable The default value is Enable.
Mode	Specifies the mode of the Spanning Tree.	stp or rstp
Forward Time	Specifies the Spanning Tree forward time in seconds.	Range: 4-30 seconds
Hello Time	Specifies the Hello time in seconds.	Range: 1 to10 seconds
Max Age	Specifies the spanning-tree bridge maximum age in seconds.	Range: 6 to 40 seconds
Loopback Guard	Specifies the loopback guard status.	Enable or Disable

Path Cost Method	Specifies the speed of the interface.	Method: <ul style="list-style-type: none"> <li>• long - for 32 bit based values for default port path costs.</li> <li>• short - 16 bit based values for default port path costs.</li> </ul> The default method is long.
Priority	Specifies the port priority.	Range: 0 to 61440 in steps of 4096 The default value is 32768.
BPDU Filtering	Specifies that BPDU packets are filtered when the spanning tree is disabled on an interface.	
BPDU Flooding	Specifies that BPDU packets are flooded unconditionally when the spanning tree is disabled on an interface.	

## Configuring Dot1x

This chapter describes how to configure dot1x port-based authentication on the Cisco Enterprise NFWIS portal. dot1x prevents unauthorized devices (clients) from gaining access to the network. It is a standard for media-level (Layer 2) access control, offering the capability to permit or deny network connectivity based on the identity of the end user or device. The dot1x is disabled by default. You can click on **edit** to enable dot1x.

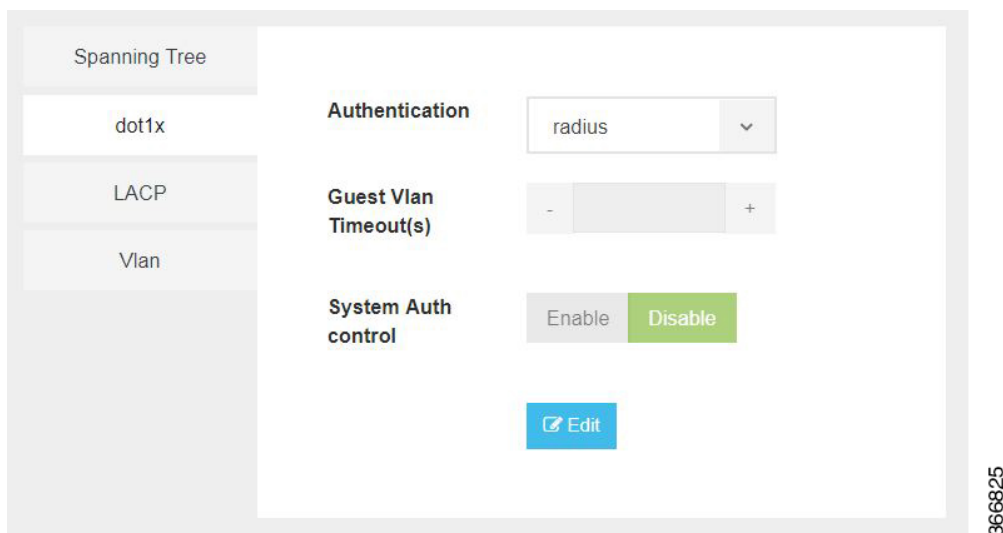

The configuration of dot1x has the following parameters:

**Table 4: Dot1x Parameters**

Parameter	Description	Values
-----------	-------------	--------

Authentication	Specifies the authentication type for the port.	radius or none The default value is radius.
Guest VLAN Timeout(s)	Specifies the time delay in seconds between enabling Dot1X (or port up) and adding the port to the guest VLAN.	Range: 30 to 180 seconds
System Auth control	Specifies the authentication control.	Enable or Disable

## Configuring LACP

The Link Aggregation Control Protocol (LACP) enables you to bundle several physical ports together to form a single logical channel. LACP enables you to form a single Layer 2 link automatically from two or more Ethernet links. This protocol ensures that both ends of the Ethernet link are functional and are part of the aggregation group.

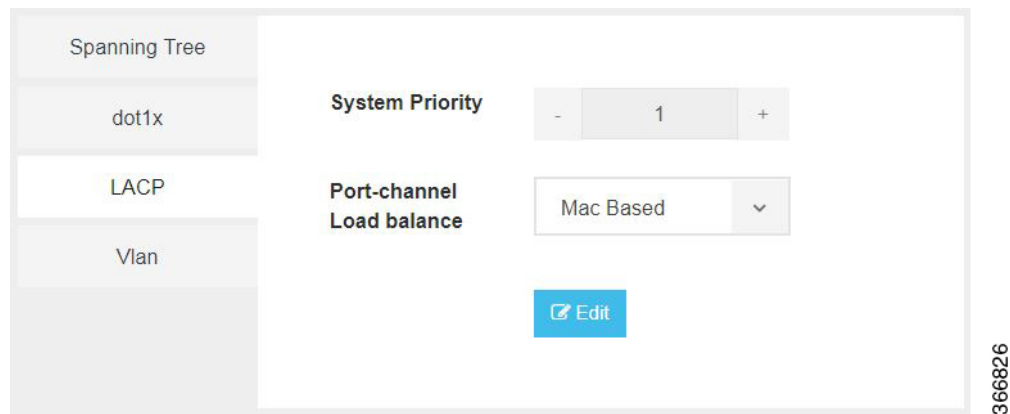

LACP uses the following parameters to control aggregation:

**Table 5: LACP Parameters**

Parameter	Description	Values
System Priority	Specifies the port priority.	Range: 1 to 65535
Port-channel load balance	Specifies the load balance of the port channel.	Mac Based or IP Based

## Configuring VLAN

You can use virtual LANs (VLANs) to divide the network into separate logical areas. VLANs can also be considered as broadcast domains. Any switch port can belong to a VLAN, and unicast, broadcast, and multicast packets are forwarded and flooded only to end stations in that VLAN. Each VLAN is considered a logical network, and packets destined for stations that do not belong to the VLAN must be forwarded through a router.

You can configure VLANs in the range <1-2349>|<2450-4093> for a specified switch port.

**Note**

- When you use multiple Virtual Network Interface Cards (VNICs) in your VLAN, ensure that each of the VNICs are configured within the VLAN network.
- The Cisco ENCS hardware switch is typically connected to the Open vSwitch (OVS) using physical connections (like Ethernet cables) which are then represented as ports within the Open vSwitch configuration. When a VLAN is set up on the Cisco ENCS switch, perform the corresponding configuration on the OVS as well. Assign a VLAN tag to the OVS port that corresponds to the hardware switch port.
- Use native VLANs for untagged traffic. If a hardware switch port is configured to use a certain VLAN as native, corresponding OVS port should also be configured to tag the untagged incoming traffic with the same VLAN. Allowed VLAN lists define which VLANs are allowed on a port.
- While a hardware switch and OVS are logically connected, configurations do not automatically propagate between the two. Manually configure the both to ensure consistency and correct networking behavior.

## Configuring General Settings

You can configure general settings using the following parameters for each switch interface:

- Interface—Name of the interface

- Description—Set the description per interface
- Speed—10/100/1000 MBPS
- Dot1x Auth—802.1x, mac or both
- PoE Method—auto, never or four-pair
- PoE Limit—0-60000mW
- Admin Status—enable or disable

## Configuring Advanced Settings

You can make the advanced settings using the following parameters for each switch interface:

- Mode—access, dot1q-tunnel, private-vlan, or trunk
- Access Vlan—Specifies the number of VLANs.
- Allowed Vlan—All or VLAN IDs
- Native Vlan—Specifies the VLAN ID. You can enter a value from one of the following ranges:
  - 1 to 2349
  - 2450 to 4093
- Dot1q Tunnel Vlan—Specifies the Layer 2 tunnel port.
- Community—Specifies the community number. Range: 1 to 29
- Protected Port—Yes or No



**Note** The VLAN configuration takes effect only if the global VLANs are also configured with the same values in [Configuring VLAN, on page 7](#).

## Configuring Spanning Tree per Interface

The image displays two screenshots of a network configuration interface, specifically the 'Spanning Tree' configuration page for an interface. The interface is divided into three tabs: 'General Settings', 'Advanced Settings', and 'Spanning Tree'. The 'Spanning Tree' tab is active in both screenshots.

**Top Screenshot (ID: 366830):** This screenshot shows the following configuration options:

- Spanning Tree:** A toggle switch set to 'Enable'.
- Cost:** A dropdown menu with the text 'Choose from 1-200000000'.
- Priority:** A dropdown menu set to '128'.
- Link Type:** A dropdown menu.
- BPDU Guard:** A toggle switch set to 'Disable'.
- Root Guard:** A toggle switch set to 'Disable'.
- Port Fast:** A dropdown menu set to 'auto'.

**Bottom Screenshot (ID: 366831):** This screenshot shows the following configuration options:

- Spanning Tree:** A toggle switch set to 'Disable'.
- BPDU Filtering:** A toggle switch set to 'Enable'.
- BPDU Flooding:** A toggle switch set to 'Disable'.

Both screenshots include 'Apply' and 'Cancel' buttons at the bottom.

You can configure spanning tree for each switch interface using the following parameters:

- Spanning Tree—Enable or Disable
- Cost—Specifies the cost. Range: 1 to 200000000
- Priority—Specifies the port priority. Range: 0 to 240, default value is 128
- Link Type—point-to-point or shared
- BPDU Guard—Enable or Disable
- Root Guard—Enable or Disable

- Port Fast—auto or enable
- BPDU Filtering—Specifies that BPDU packets are filtered when the spanning tree is disabled
- BPDU Flooding—Specifies that BPDU packets are flooded when the spanning tree is disabled

## Configure Storm Control

Storm control is used to monitor incoming traffic levels and limit excessive flow of packets on any user facing switch port that could cause a traffic storm. Traffic storms can lead to device instability and unintended behavior.

You can configure storm control from Cisco NFVIS Portal, from **Storm Control** tab.

The screenshot shows the Storm Control configuration page with the following settings:

Category	Option	Value / State
Multicast	Enable/Disable	Enable
Storm Control Suppression	Level	57 (Slider)
Broadcast	Enable/Disable	Enable
Storm Control Suppression	Level	7000 (Text Input)
Unicast	Enable/Disable	Disable

Storm control can be configured for specific type of traffic - unicast or multicast or broadcast. The suppression range can be in terms of a percentage level (1-100) or Kbps value (1-1000000).

# Configure Additional WAN Transport Connectivity On ENCS Switch Ports

Table 6: Feature History

Feature Name	Release Information	Description
Configure Additional WAN Transport Connectivity On ENCS Switch Ports	NFVIS Release 4.10	This feature enables configuring additional Transport Locator (TLOC) an attachment point. The attachment point is where a Cisco WAN Edge device connects to a WAN transport using ENCS LAN ports as WAN ports. This is in addition to the currently available WAN connectivity options that is restricted to just two WAN ports.

Starting from NFVIS Release 4.10, map LAN SR-IOV (Single Root Input or Output Virtualization) with Cisco ISRV or Cisco Catalyst 8000V to configure additional WAN transport connectivity on ENCS switch ports. The following are the changes to ENCS LAN and WAN ports connectivity:

- The WAN circuit TLOC terminates on layer 3 ports (GE0-0 or GE0-1).
- The WAN circuit TLOC physically connects to any switch port (GE1/0 - GE1/7).
- The LAN traffic flows through the switchports (GE1/0 - GE1/7).



**Note** Cisco Security Group Tag (SGT) is added to the LAN interfaces which are propagated to all the TLOCs that are handled by VNFs such as Cisco ISRV or Cisco Catalyst 8000V. For more information see, [Cisco TrustSec Integration](#).

## Prerequisites to Configure Additional WAN Transport Connectivity On ENCS Switch Ports

Setup Cisco ISRV or Cisco Catalyst 8000V devices using Cisco NFVIS.

## Configure Additional WAN Transport Connectivity Using MPLS

This section provides an example configuration to configure additional WAN ports on ENCS switch ports with ISRV and Catalyst 8000V using MPLS:

1. Enter the configuration mode:

```
config-transaction
```

2. Enter the sdwan mode:

```
sdwan
```

3. Configure the interface into a tunnel interface:

```
tunnel interface
```

4. Configure an interface type and enter the interface configuration mode:

```
interface GigabitEthernet2
```

5. Configure an encapsulation for a tunnel interface:

```
encapsulation ipsec
```

6. Assign a color to a WAN transport tunnel:

```
color mpls
```

7. Configure the services that are allowed on a tunnel interface:

```
allow-service all
no allow-service bgp
allow-service dhcp
allow-service dns
allow-service icmp
no allow-service sshd
no allow-service netconf
allow-service ntp
no allow-service ospf
no allow-service stun
allow-service https
no allow-service snmp
no allow-service bfd
```

Here's the complete configuration example for configuring additional WAN ports on ENCS switch ports with ISRV and Catalyst 8000V using MPLS:

```
sdwan
interface GigabitEthernet2
tunnel-interface
encapsulation ipsec
color mpls
max-control-connections 0
allow-service all
no allow-service bgp
allow-service dhcp
allow-service dns
allow-service icmp
no allow-service sshd
no allow-service netconf
allow-service ntp
no allow-service ospf
no allow-service stun
allow-service https
no allow-service snmp
no allow-service bfd
!
```

## Configure Additional WAN Transport Connectivity Using Biz Internet

This section provides an example configuration to configure additional WAN ports on ENCS switch ports with ISRV and Catalyst 8000V using biz internet:

1. Enter the configuration mode:

```
config-transaction
```

2. Enter the sdwan mode:

```
sdwan
```

3. Configure the interface into a tunnel interface:

```
tunnel interface
```

4. Configure an interface type and enter the interface configuration mode:

```
interface GigabitEthernet5.101
```

5. Configure an encapsulation for a tunnel interface:

```
encapsulation ipsec
```

6. Restrict the biz internet colors:

```
color biz internet restrict
```

7. Configure the services that are allowed on a tunnel interface:

```
no allow-service bgp
allow-service dhcp
allow-service dns
allow-service icmp
no allow-service sshd
no allow-service netconf
no allow-service ntp
no allow-service ospf
no allow-service stun
allow-service https
no allow-service snmp
no allow-service bfd
```

Here's the complete configuration example for configuring additional WAN ports on ENCS switch ports with ISRV and Catalyst 8000V using biz internet:

```
sdwan
interface GigabitEthernet5.101
tunnel-interface
encapsulation ipsec
color biz-internet restrict
no allow-service bgp
allow-service dhcp
allow-service dns
allow-service icmp
no allow-service sshd
no allow-service netconf
no allow-service ntp
no allow-service ospf
no allow-service stun
allow-service https
no allow-service snmp
no allow-service bfd
!
```

## Configure Additional WAN Transport Connectivity Using Public Internet

This section provides an example configuration to configure additional WAN ports on ENCS switch ports with ISRV and using public internet:

1. Enter the configuration mode:

```
config-transaction
```

2. Enter the sdwan mode:

```
sdwan
```

3. Configure the interface into a tunnel interface:

```
tunnel interface
```

4. Configure an interface type and enter the interface configuration mode:

```
interface GigabitEthernet6
```

5. Configure an encapsulation for a tunnel interface:

```
encapsulation ipsec
```

6. Restrict the public internet colors:

```
color public internet restrict
```

7. Configure the services that are allowed on a tunnel interface:

```
no allow-service bgp
allow-service dhcp
allow-service dns
allow-service icmp
no allow-service sshd
no allow-service netconf
allow-service ntp
no allow-service ospf
no allow-service stun
allow-service https
no allow-service snmp
no allow-service bfd
```

Here's the complete configuration example for configuring additional WAN ports on ENCS switch ports with ISRV and Catalyst 8000V using public internet:

```
sdwan
interface GigabitEthernet6
tunnel-interface
encapsulation ipsec
color public-internet restrict
no allow-service bgp
allow-service dhcp
allow-service dns
allow-service icmp
no allow-service sshd
no allow-service netconf
allow-service ntp
no allow-service ospf
no allow-service stun
allow-service https
no allow-service snmp
```

```
no allow-service bfd
!
```

## Configuration Example of Additional WAN Transport Connectivity to Cisco ISRv or Catalyst 8000V

The following example shows the interfaces mapped to Cisco ISRv or Cisco Catalyst 8000V VM:

```
Name: S200-CE1
Deployment Name : S200-CE1
VM Group Name : S200-CE1
State: ALIVE
Internal State: VM_ALIVE_STATE
Bootup Time: 600
Image: isrv-universalk9.17.03.03.tar.gz
Flavor: ISRv-medium

VCPU# Memory(MB) Disk(MB)
-----
4 4096 8192

Low Latency: true
VCPU CPU CORE SOCKET
-----
0 2 2 0
1 3 3 0
2 4 4 0
3 5 5 0

NICID VNIC NETWORK IP MAC-ADDRESS MODEL PORT-FORWARD
-----
0 vnic0 int-mgmt-net 10.20.0.2 52:54:00:cf:41:cc virtio <----- Internal Monitoring
1 vnic1 LAN-SRIOV-20 - 52:54:00:90:3b:8c None <---- connects to GE1/0 for TLOC MPLS
2 vnic2 LAN-SRIOV-21 - 52:54:00:8a:c1:a1 None <---- host on LAN (service VPN/VRF)
3 vnic3 LAN-SRIOV-22 - 52:54:00:9c:17:db None <---- host on LAN (service VPN/VRF)
4 vnic4 LAN-SRIOV-23 - 52:54:00:f6:12:eb None <---- connects to GE1/6 for TLOC Biz-Internet
5 vnic5 GE0-0-SRIOV-1 - 52:54:00:e8:19:74 None <----- connects to GE0-0 for TLOC
Public-Internet
6 vnic6 GE0-1-SRIOV-1 - 52:54:00:53:d4:d7 None <----- unused
```

## Verify Mapping of LAN SR-IOV with Cisco ISRv or Cisco Catalyst 8000V Using Cisco ISRv or Cisco Catalyst 8000V CLI

The following is a sample output from the **show sdwan control connections** command:

```
router# show sdwan control connections
PEER PEER CONTROLLER
PEER PEER PEER SITE DOMAIN PEER PRIV PEER PUB GROUP
TYPE PROT SYSTEM IP ID ID PRIVATE IP PORT PUBLIC IP PORT LOCAL COLOR PROXY STATE UPTIME ID
-----
vsmart dtls 10.0.0.201 10000 1 192.10.10.200 12446 192.10.10.200 12446 public-internet No
up 19:00:27:09 0
vbond dtls 0.0.0.0 0 0 10.10.0.3 12346 10.10.0.3 12346 biz-internet - connect 0
vbond dtls 0.0.0.0 0 0 10.10.0.3 12346 10.10.0.3 12346 public-internet - up 19:00:27:09 0
vmanage dtls 10.0.0.101 10000 0 192.10.10.100 12446 192.10.10.100 12446 public-internet No
up 19:00:27:09 0
```

# Configuring vBranch High Availability

High availability design provides redundancy for WAN, LAN, ENCS device, vRouter, vFirewall VNF level redundancy.

A branch site can have two routers for redundancy. If vEdge-cloud router is chosen, Each of the vedge-cloud router maintains:

- A secure control plane connection, via a DTLS connection, with each vSmart controller in its domain
- A secure data plane connection with the other vEdge routers at the site

Because both vEdge routers receive the same routing information from the vSmart controllers, each one is able to continue to route traffic if one should fail, even if they are connected to different transport providers.

Two firewalls are placed in a group and their configuration is synchronized to prevent a single point of failure on your network. A heartbeat connection between the firewall peers ensures seamless failover in the event that a peer goes down. Setting up two firewalls in an HA pair provides redundancy and allows you to ensure business continuity.

## Prerequisites for vBranch HA

The WAN links are active on both Cisco ENCS1 and Cisco ENCS2. Each of the ENCS WAN link is connected to the WAN network (most cases with two SPs), with two ENCSs in an active-active mode.

The LAN facing links of both Cisco ENCS devices are connected to an external switch (as an uplink), and all the devices on the LAN segment are also connected to the external switch. There should be no LAN device connecting directly to the Cisco ENCS internal switch.

Two vRouters and the Two vFirewalls have full mesh L3 connectivity.

VMs and VNFs on both ENCS devices must be configured identical.

## SD-Branch HA Design and Topology

In HA design, there are two sets of VLANs. Traffic path is between the VNFs and traffic from or towards LAN.

To protect against cable connection issue and box failure, there is back-to-back cable between ENCS and connection from each ENCS to the external switch.

When using Cisco ENCS and Cisco switches, common expectation is to use PVST+, detect loops and switch specific ports to BLOCKING mode. ENCS switch does not support PVST (Per VLAN spanning tree). By Default, RSTP could end up blocking ENCS port back-to-back connection, this will result in blocking traffic path between the VNFs.

The recommended solution is to use MSTP in ENCS and the external switches. The following topology and configuration provides a step-by-step procedure with reasoning for specific configuration use. There are two instances of MSTP created. One for handling traffic path between VNFs and the second for handling traffic from or towards LAN.



---

**Note** In cases where external switch cannot be configured for MSTP, RSTP is used and the two links back-2-back between ENCS is not in port-channel.

- One of the links carries traffic between VNFs by configuring disable spanning tree. The second back-to-back link between ENCS processes RSTP and forward or block for the traffic from or towards LAN.
  - From each of the ENCS, a third physical link connects to the external switch. This also forwards or blocks the traffic from or towards LAN depending on the RSTP decisions.
-

### Physical Device Connections

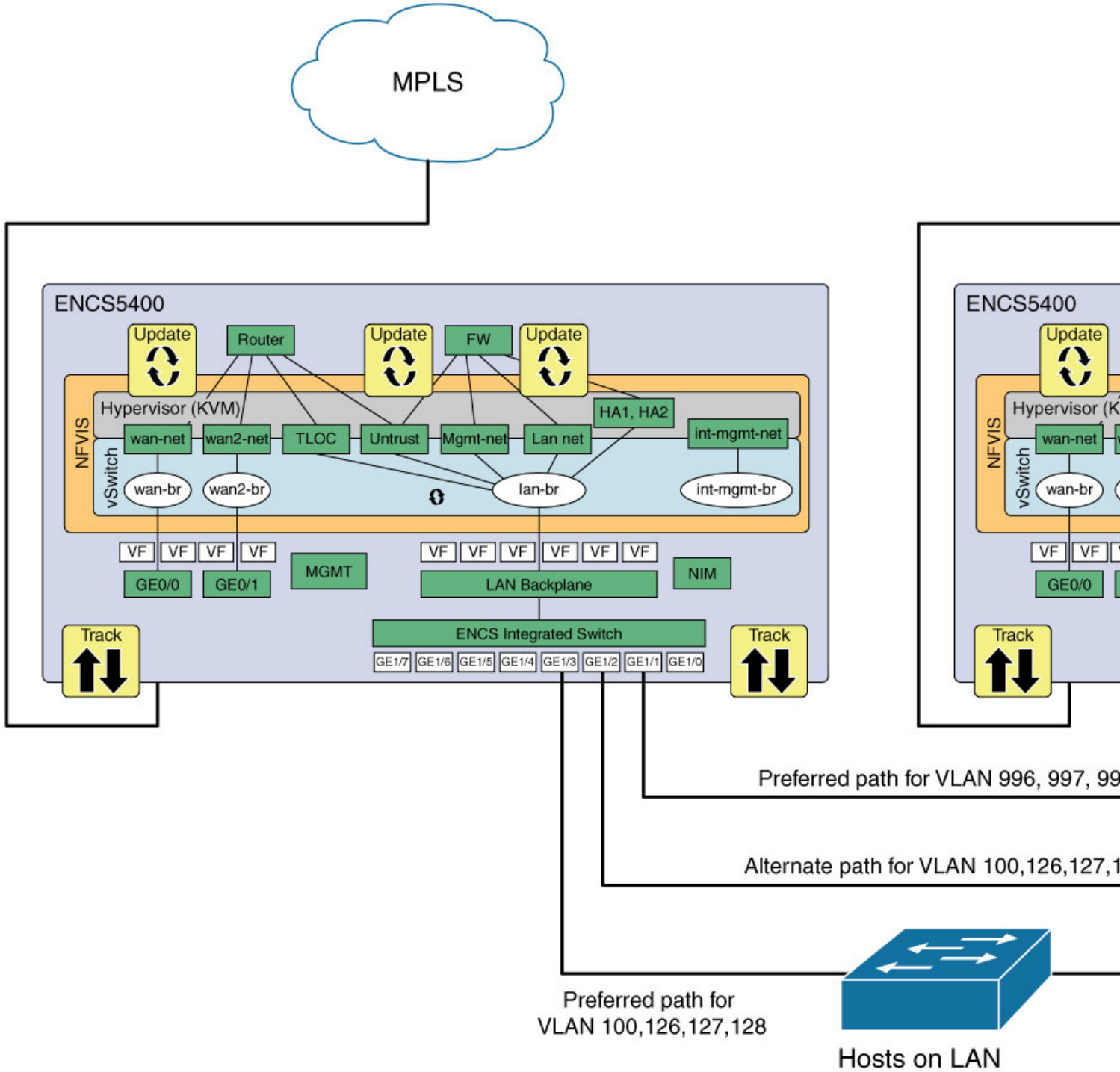

## VM and Service Chain Network Connection

Figure 1: ENCS-Left

Name	Status	Profile	Port Forwarding	vnic										Management IP	Actions		
				0	1	2	3	4	5	6	7	8	9				
FIREWALL	Active	VMS-100		mgmt-net	Utrust	HA1	HA2	Trust								10.20.0.2	
ROUTER	Active	svs-small	2001 => 22	internal	wan-net2	pt-2-pt	Utrust	mgmt-net								10.20.0.2	

Figure 2: ENCS-Right

Name	Status	Profile	Port Forwarding	vnic										Management IP	Actions		
				0	1	2	3	4	5	6	7	8	9				
FIREWALL	Active	VMS-100		mgmt-net	Utrust	HA1	HA2	Trust								10.20.0.2	
ROUTER	Active	svs-small	2001 => 22	internal	wan-net2	pt-2-pt	Utrust	mgmt-net								10.20.0.2	



**Note** In the absence of firewall in the design, the router is directly connected to the LAN side. Pt-to-Pt network extends the TLOC connection across the ENCS devices and VRRP is enabled in the router LAN facing connection.

## Isolating LAN and Transit Link Traffic for vBranch HA

Traffic from or towards LAN and traffic between the VNFs are isolated by configuring different VLANs for each traffic since both links are connected to the same ENCS internal switch. If you do not isolate the traffic, both LAN traffic and transit link will flow through the same internal switch on the Cisco ENCS.

## Enable Port Tracking and Virtual NIC Update

The configured VNICs tracks the state of the ports based on the PNICs notifications. To verify the state of the port, use **show interface** or **ethtool** commands. You can also use commands specific to the VM, that displays the interface link state.

To configure track state on GE0-0 & GE0-1:

```
configure terminal
pnic GE0-0 track-state ROUTER 1
end
```

ENCS-Left# **support show ifconfig GE0-0**

```
GE0-0: flags=4611<UP,BROADCAST,ALLMULTI,MULTICAST> mtu 9216
ether 70:db:98:c3:df:28 txqueuelen 1000 (Ethernet)
```

To configure track state on switch port:

```
configure terminal
switch interface gigabitEthernet 1/3 track-state FIREWALL 4
end
```

```
ENCS-Left# show vm_lifecycle deployments FIREWALL
```

```
Name: FIREWALL
Deployment Name : FIREWALL
VM Group Name : FIREWALL
State: ALIVE
Internal State: VM_INERT_STATE
Bootup Time: -1
Image: Palo-Alto-8.1.3.tar.gz
Flavor: VM-100
```

```
VCPU#   Memory (MB)   Disk (MB)
-----
2       7168            61440
```

```
Low Latency: true
VCPU CPU CORE SOCKET
-----
0     3     3     0
1     2     2     0
```

```
NICID  VNIC    NETWORK IP    MAC-ADDRESS          MODEL    PORT-FORWARD
-----
0      vnic6  mgmt-net -    52:54:00:2b:72:d2   virtio
1      vnic7  Untrust -    52:54:00:eb:a3:e7   virtio
2      vnic8  HA1    -    52:54:00:f4:de:e5   virtio
3      vnic9  HA2    -    52:54:00:12:f8:21   virtio
4      vnic10 Trust  -    52:54:00:7a:6b:e9   virtio
```

```
ENCS-Left# support show ifconfig vnic10
```

```
vnic10: flags=4163<UP,BROADCAST,RUNNING,MULTICAST> mtu 9216
        inet6 fe80::fc54:ff:fe7a:6be9 prefixlen 64 scopeid 0x20<link>
        ether fe:54:00:7a:6b:e9 txqueuelen 4000 (Ethernet)
```

## Packet Flow for SD-Branch HA

This section explains high-level packet flow in non-failure and failure cases.

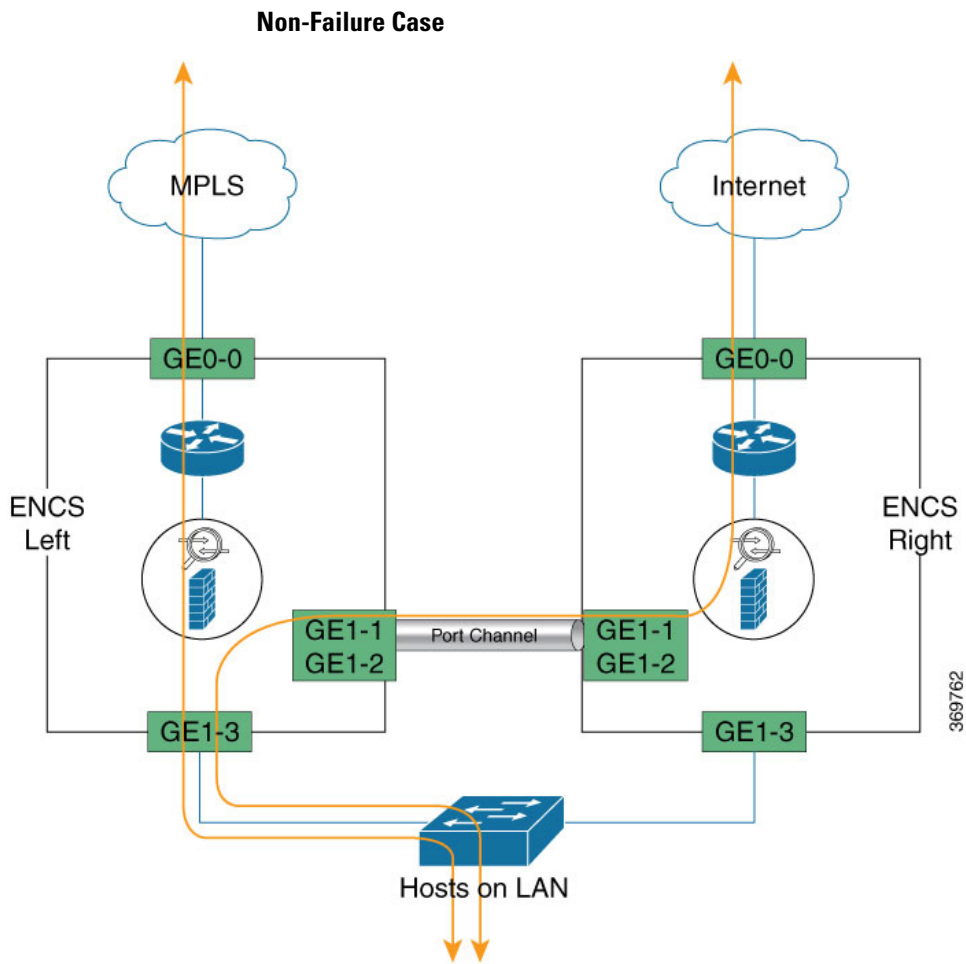

In the non-failure case, both ENCS devices are Active, up and running

- LAN to WAN through the ENCS1 Firewall and ENCS1 Router
- LAN to WAN through the ENCS1 Firewall and ENCS2 Router
- WAN to LAN through ENCS1 Router and ENCS1 Firewall
- WAN to LAN through ENCS2 Router and ENCS1 Firewall

**Failure Case**

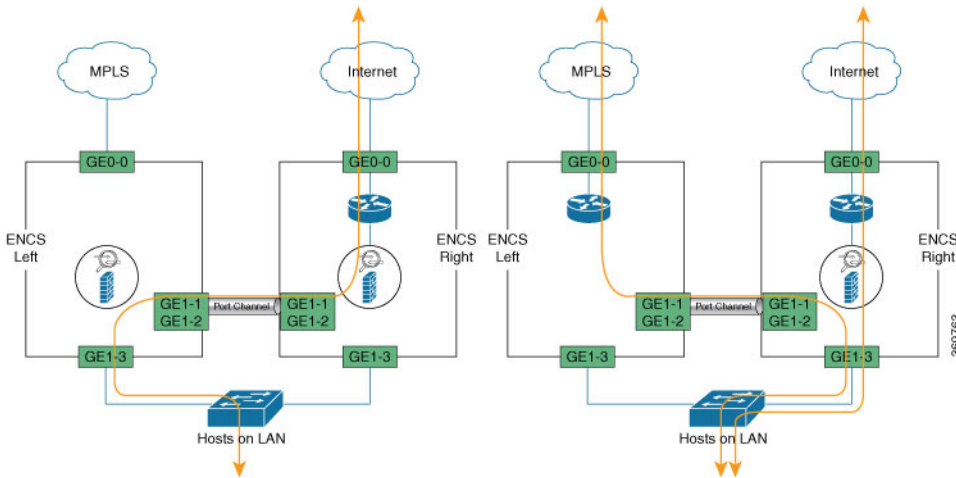

Following are failures that a router must be designed and configured to adapt

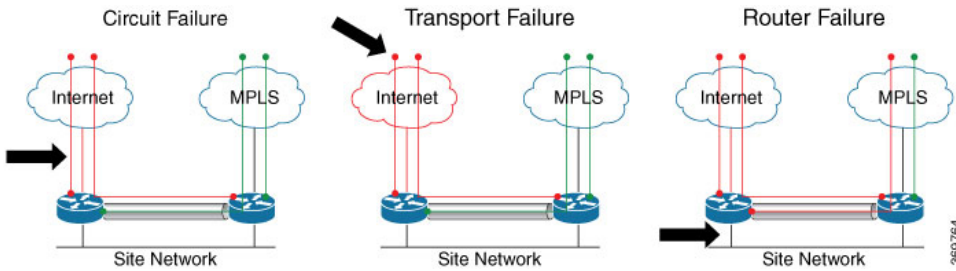

The conditions that trigger a firewall failover are:

- One or more of the monitored interfaces fail. (Link Monitoring)
- One or more of the destinations specified on the firewall cannot be reached. (Path Monitoring)
- The firewall does not respond to heartbeat polls. (Heartbeat Polling and Hello messages)

## Configuration Examples and Usage Description

ENCS-Left and ENCS-Right with Same Config	Description or Reasons for configuration
<pre>networks network wan-net   bridge wan-br   ! networks network HA1   vlan [ 126 ]   trunk false   bridge lan-br   ! networks network HA2   vlan [ 127 ]   trunk false   bridge lan-br   ! networks network Trust   vlan [ 128 ]   bridge lan-br   ! networks network Untrust   vlan [ 998 ]   bridge lan-br   ! networks network mgmt-net   vlan [ 100 ]   trunk false   bridge lan-br   ! networks network pt-2-pt   vlan [ 996 997 ]   bridge lan-br</pre>	<p>In a HA design involving a router or Firewall, there are 3 to 6 paths required. ENCS platform has 2 WAN facing ports and 8 LAN facing ports.</p> <ul style="list-style-type: none"> <li>• WAN facing ports are reserved for connection to WAN circuits.</li> <li>• LAN facing ports are the only set of available ports for creating the 3 to 6 path required.</li> </ul> <p>Between VNFs and LAN, OVS or SR-IOV VFs and physical switch ports are the two Layer2 entities to traverse.</p>
<pre>! vlan 1 ! vlan 100 ! vlan 126 ! vlan 127 ! vlan 128 ! vlan 996 ! vlan 997 ! vlan 998 ! spanning-tree enable spanning-tree mode mst spanning-tree mst 2 priority 61440 spanning-tree mst configuration   name mst_LAN   instance 1 vlan 996-998   instance 2 vlan 100,126-128 !</pre>	<p>VLAN must be explicitly created before they are used in the interfaces.</p> <p>Enable MSTP. For MST group 2 carrying “Traffic towards/from LAN”, force the External Switch to become the ROOT using the “mst &lt;group&gt; priority &lt;value&gt;” CLI. The Higher the value, lower the chance of becoming spanning-tree ROOT.</p> <p>“priority” configuration is NOT required for the MST group 1 carrying “Traffic between VNFs”. There is NO loop possibility for MST group 1 VLANs.</p>

ENCS-Left and ENCS-Right with Same Config	Description or Reasons for configuration
<pre> nfvis# show running-config switch switch interface gigabitEthernet1/1   no shutdown   channel-group 1 mode auto ! interface gigabitEthernet1/2   no shutdown   channel-group 1 mode auto ! switch interface port-channel1   negotiation auto   no shutdown   spanning-tree mst 1 cost 200000000   spanning-tree mst 2 cost 200000000   switchport mode trunk   switchport trunk native vlan 1   switchport trunk allowed vlan 100,126-128,996-998 ! </pre>	<p>For the back-to-back ENCS connection, link redundancy is achieved using port-channel configuration. Interfaces that are belong to a port-channel group use configuration from “interface port-channel x”</p> <p>Goal is to prefer the direct links from ENCS to the External Switch for “Traffic towards/from LAN”. In ENCS back-to-back connection, Spanning tree cost is HIGH for MST group carrying “Traffic towards/from LAN”. This config will block one of the ENCS back-to-back interfaces for breaking the loop for MST group carrying “Traffic towards/from LAN”.</p>

#### Status of MST instances.

For MST instance 1, “Traffic between the VNFs”, back-to-back portchannel link is root and forwarding state.

For MST instance 2, “Traffic from/towards the LAN”, links connected to External Switch are in forwarding state, path via back-to-back portchannel link is “Blocking state”. If one of the Links fail between ENCS and External switch, portchannel path for MST instance 2 will be unblocked.

ENCS-Left# show switch vlan detailed					ENCS-Right# show switch vlan detail						
VLAN ID	VLAN NAME	TAGGED PORTS	UNTAGGED PORTS	CREATED BY	VLAN ID	VLAN NAME	TAGGED PORTS	UNTAGGED PORTS	CREATED BY		
1	1	1	None		1	1	1	None			
gi0,gi4-6,te2,po2-4	DefaultVoiceVLAN				gi0,gi4-6,te2,po2-4	DefaultVoiceVLAN					
100	100	100	gi3,te2,po1	gi7	100	100	100	gi3,te2,po1	gi7		
	Manual					Manual					
126	126	126	gi3,te2,po1	None	126	126	126	gi3,te2,po1	None		
	Manual					Manual					
127	127	127	gi3,te2,po1	None	127	127	127	gi3,te2,po1	None		
	Manual					Manual					
128	128	128	gi3,te2,po1	None	128	128	128	gi3,te2,po1	None		
	Manual					Manual					
996	996	996	te2,po1	None	996	996	996	te2,po1	None		
	Manual					Manual					
997	997	997	te2,po1	None	997	997	997	te2,po1	None		
	Manual					Manual					
998	998	998	te2,po1	None	998	998	998	te2,po1	None		
	Manual					Manual					
ENCS-Left# show switch spanning-tree mstp summary					ENCS-Right# show switch spanning-tree mstp summary						
spanning-tree mstp summary ist-info summary					spanning-tree mstp summary ist-info summary						
admin-status enabled					admin-status enabled						
spanning-tree mstp summary ist-info summary					spanning-tree mstp summary ist-info summary						
Operation-mode MSTP					Operation-mode MSTP						
spanning-tree mstp summary ist-info summary					spanning-tree mstp summary ist-info summary						
Port-Cost-Method long					Port-Cost-Method long						
spanning-tree mstp summary ist-info summary					spanning-tree mstp summary ist-info summary						
Loopback-guard disabled					Loopback-guard disabled						
spanning-tree mstp summary ist-info root					spanning-tree mstp summary ist-info root						
Priority 32768					Priority 32768						
spanning-tree mstp summary ist-info root					spanning-tree mstp summary ist-info root						
Address 70:db:98:c3:df:14					Address 70:db:98:c3:df:14						
spanning-tree mstp summary ist-info root Cost					spanning-tree mstp summary ist-info root Cost						
0					0						
spanning-tree mstp summary ist-info root Port					spanning-tree mstp summary ist-info root Port						
LAG1					0						
spanning-tree mstp summary ist-info root					spanning-tree mstp summary ist-info root						
Hello-Time 2					Hello-Time 2						
spanning-tree mstp summary ist-info root					spanning-tree mstp summary ist-info root						
Max-Age 20					Max-Age 20						
spanning-tree mstp summary ist-info root					spanning-tree mstp summary ist-info root						
Forward-Delay 15					Forward-Delay 15						
spanning-tree mstp summary ist-info bridge					spanning-tree mstp summary ist-info bridge						
Priority 32768					Priority 32768						
spanning-tree mstp summary ist-info bridge					spanning-tree mstp summary ist-info bridge						
Address 70:db:98:c3:df:a0					Address 70:db:98:c3:df:14						
spanning-tree mstp summary ist-info bridge					spanning-tree mstp summary ist-info bridge						
Hello-Time 2					Hello-Time 2						
spanning-tree mstp summary ist-info bridge					spanning-tree mstp summary ist-info bridge						
Max-Age 20					Max-Age 20						
spanning-tree mstp summary ist-info bridge					spanning-tree mstp summary ist-info bridge						
Forward-Delay 15					Forward-Delay 15						
spanning-tree mstp summary ist-info					spanning-tree mstp summary ist-info						
.....					.....						
.....					.....						
INSTANCE	PRIORITY	DSG	ROOT	ADDRESS	BRIDGE	INSTANCE	PRIORITY	DSG	ROOT	ADDRESS	BRIDGE

ADDRESS						ADDRESS					
1	32768		70:db:98:c3:df:14			1	32768		70:db:98:c3:df:14		
			70:db:98:c3:df:a0						70:db:98:c3:df:14		
2	61440		f0:b2:e5:56:e4:80			2	61440		f0:b2:e5:56:e4:80		
			70:db:98:c3:df:a0						70:db:98:c3:df:14		
INST ID	PORT ROLE	STATE	PRIO. NBR	COST	STS	INST ID	PORT ROLE	STATE	PRIO. NBR	COST	STS
1	gil/0	enabled	128.1	2000000	disabled	1	gil/0	enabled	128.1	2000000	disabled
	disabled						disabled				
1	gil/3	enabled	128.4	20000		1	gil/3	enabled	128.4	20000	
	forwarding	designated					forwarding	designated			
1	gil/4	enabled	128.5	2000000	disabled	1	gil/4	enabled	128.5	2000000	disabled
	disabled						disabled				
1	gil/5	enabled	128.6	2000000	disabled	1	gil/5	enabled	128.6	2000000	disabled
	disabled						disabled				
1	gil/6	enabled	128.7	2000000	disabled	1	gil/6	enabled	128.7	2000000	disabled
	disabled						disabled				
1	gil/7	enabled	128.8	2000000	disabled	1	gil/7	enabled	128.8	2000000	disabled
	disabled						disabled				
2	gil/0	enabled	128.1	2000000	disabled	2	gil/0	enabled	128.1	2000000	disabled
	disabled						disabled				
2	gil/3	enabled	128.4	20000		2	gil/3	enabled	128.4	20000	
	forwarding	root					forwarding	root			
2	gil/4	enabled	128.5	2000000	disabled	2	gil/4	enabled	128.5	2000000	disabled
	disabled						disabled				
2	gil/5	enabled	128.6	2000000	disabled	2	gil/5	enabled	128.6	2000000	disabled
	disabled						disabled				
2	gil/6	enabled	128.7	2000000	disabled	2	gil/6	enabled	128.7	2000000	disabled
	disabled						disabled				
2	gil/7	enabled	128.8	2000000	disabled	2	gil/7	enabled	128.8	2000000	disabled
	disabled						disabled				
INST ID	PORT ROLE	STATE	PRIO. NBR	COST	STS	INST ID	PORT ROLE	STATE	PRIO. NBR	COST	STS
1	po1	enabled	128.1000	10000		1	po1	enabled	128.1000	10000	
	forwarding	root					forwarding	designated			
1	po2	enabled	128.1001	2000000		1	po2	enabled	128.1001	2000000	
	disabled	disabled					disabled	disabled			
1	po3	enabled	128.1002	2000000		1	po3	enabled	128.1002	2000000	
	disabled	disabled					disabled	disabled			
1	po4	enabled	128.1003	2000000		1	po4	enabled	128.1003	2000000	
	disabled	disabled					disabled	disabled			
2	po1	enabled	128.1000	200000000		2	po1	enabled	128.1000	200000000	
	blocking	alternate					forwarding	designated			
2	po2	enabled	128.1001	2000000		2	po2	enabled	128.1001	2000000	
	disabled	disabled					disabled	disabled			
2	po3	enabled	128.1002	2000000		2	po3	enabled	128.1002	2000000	
	disabled	disabled					disabled	disabled			
2	po4	enabled	128.1003	2000000		2	po4	enabled	128.1003	2000000	
	disabled	disabled					disabled	disabled			
ENCs-Left#						ENCs-Right#					

From the above summary output, MST instances indicates ID and associated VLAN, and then displays all interfaces as part of VLAN instances. This behaviour differs from the way MST instances are displayed on other Cisco switching platforms.

## External Switch MST Configuration



**Note** It is recommended that VLAN 996-998 is not allowed through the interfaces connecting to ENCS-Left and ENCS-Right. As a result, the external switch MSTP does not participate for VLAN 996-998.

**Table 7:**

<pre> vlan 100,126-128 ! spanning-tree mode mst spanning-tree extend system-id spanning-tree uplinkfast ! spanning-tree mst configuration name mst_LAN instance 1 vlan 996-998 instance 2 vlan 100, 126-128 ! interface GigabitEthernet1/0/1 switchport trunk allowed vlan 100,126-128 switchport mode trunk ! interface GigabitEthernet1/0/2 switchport trunk allowed vlan 100,126-128 switchport mode trunk </pre>	<p>VLANs carrying “Traffic between the VNFs” are NOT sent to the External Switch.</p> <p>MST instance priority and MST link COST are kept default in the External Switch.</p> <p>MST Priority and COST Configuration in ENCS ensure the External switch is the root and the Interfaces in the External switch connecting to ENCS are in Forwarding state.</p>
--	---



**Note** VLANs carrying traffic between VNFs are not used in external switch and not configured in any interface.

Switch#**show spanning-tree mst detail**

```

##### MST0    vlans mapped:    1-99,101-125,129-995,999-4094
Bridge         address f0b2.e556.e480  priority    32768 (32768 sysid 0)
Root           address 70db.98c3.df14  priority    32768 (32768 sysid 0)
                port      Gi1/0/2                path cost   0
Regional Root  address 70db.98c3.df14  priority    32768 (32768 sysid 0)
                internal cost 20000        rem hops 19
Operational    hello time 2 , forward delay 15, max age 20, txholdcount 6
Configured     hello time 2 , forward delay 15, max age 20, max hops 20

GigabitEthernet1/0/1 of MST0 is alternate blocking
Port info      port id      128.1      priority    128      cost        20000
Designated root  address 70db.98c3.df14  priority    32768      cost         0
Design. regional root  address 70db.98c3.df14  priority    32768      cost        10000
Designated bridge  address 70db.98c3.dfa0  priority    32768      port id     128.4
Timers: message expires in 5 sec, forward delay 0, forward transitions 0
Bpdus sent 27905, received 31061

GigabitEthernet1/0/2 of MST0 is root forwarding
Port info      port id      128.2      priority    128      cost        20000
Designated root  address 70db.98c3.df14  priority    32768      cost         0
Design. regional root  address 70db.98c3.df14  priority    32768      cost         0
Designated bridge  address 70db.98c3.df14  priority    32768      port id     128.4
Timers: message expires in 5 sec, forward delay 0, forward transitions 1
Bpdus sent 27904, received 31070

```

```
##### MST2      vlans mapped:   100,126-128
Bridge          address f0b2.e556.e480  priority   32770 (32768 sysid 2)
Root            this switch for MST2

GigabitEthernet1/0/1 of MST2 is designated forwarding
Port info      port id      128.1  priority   128  cost      20000
Designated root      address f0b2.e556.e480  priority 32770  cost      0
Designated bridge    address f0b2.e556.e480  priority 32770  port id   128.1
Timers: message expires in 0 sec, forward delay 0, forward transitions 1
Bpdus (MRecords) sent 27905, received 31061

GigabitEthernet1/0/2 of MST2 is designated forwarding
Port info      port id      128.2  priority   128  cost      20000
Designated root      address f0b2.e556.e480  priority 32770  cost      0
Designated bridge    address f0b2.e556.e480  priority 32770  port id   128.2
Timers: message expires in 0 sec, forward delay 0, forward transitions 1
Bpdus (MRecords) sent 27904, received 31070

Switch#
```

## CIMC Secure Overlay Support

**Table 8: Feature History**

Feature Name	Release Information	Description
CIMC Secure Overlay Support	NFVIS 4.4.1	This feature enables you to recover NFVIS when it becomes unresponsive. CIMC periodically monitors NFVIS health and when NFVIS health check fails, CIMC establishes a secure tunnel to the remote location. You can then log in to CIMC from the remote site to troubleshoot and recover NFVIS.

The CIMC secure overlay feature is a disaster recovery feature to recover an unresponsive NFVIS. NFVIS is managed from a remote location using a secure (IPsec) tunnel. If NFVIS hangs and does not recover by itself, you must reboot or reinstall NFVIS. With this feature, CIMC periodically monitors NFVIS health. CIMC gets NFVIS secure tunnel details when a secure tunnel is set up from NFVIS to the remote location. When NFVIS health check fails, CIMC waits for an hour by default for NFVIS to recover by itself. If NFVIS does not recover, CIMC establishes a secure tunnel to the remote site.

CIMC can access the remote site at the same NFVIS external IP address. At the remote site, you can log in to CIMC and do the necessary troubleshooting to recover NFVIS. After NFVIS is back up, the CIMC secure tunnel is broken and secure tunnel is established between NFVIS and the remote site again.



**Note** For this feature to work:

- Secure IPsec tunnel should be configured on NFVIS.
- The feature should be enabled in CIMC during deployment.

The following example shows how to enable secure overlay feature on CIMC:

```

ENCS# scope ipsec-tunnel
ENCS/ipsec-tunnel# show detail
  Enable Failover: no
  NFVIS Down Timeout: 3600
  Tunnel Status: NO_TUNNEL
  Seconds to Failover: 0
ENCS/ipsec-tunnel# set ?
cli                CLI options
nfvis-down-timeout Number of seconds CIMC waits before starting ipsec tunnel to
remote
tunnel-failover-enable Enables failover of ipsec tunnel when NFVIS is down

ENCS/ipsec-tunnel# set tunnel-failover-enable yes
ENCS/ipsec-tunnel# set nfvis-down-timeout 3600
ENCS/ipsec-tunnel# commit
ENCS/# show detail
  Enable Failover: yes
  NFVIS Down Timeout: 3600
  Tunnel Status: NO_TUNNEL
  Seconds to Failover: 0
ENCS/ipsec-tunnel# show
Enable Failover NFVIS Down Timeout Tunnel Status   Seconds to Failover
-----
yes              3600                TUNNEL_ESTABLISHED    0

```

The CIMC tunnel status can be one of the following:

- TUNNEL\_ESTABLISHED = all ok and remote can login to CIMC
- TUNNEL\_CONFIG\_MISSING = IPsec config was not transferred to CIMC
- TUNNEL\_ERROR = Runtime error
- UNKNOWN\_ERROR

## CIMC TACACS Support

**Table 9: Feature History**

Feature Name	Release Information	Description
CIMC TACACS Support	NFVIS 4.2.1	CIMC TACACS configuration support enabled on NFVIS.

TACACS+ is a security protocol that provides centralized validation of users attempting to gain access to a router or network access server. TACACS+ services are maintained in a database on a TACACS+ server running, typically, on a UNIX or Windows NT workstation. You must configure a TACACS+ server before you configure the TACACS+ features on your network access server and make them available.

On the TACACS+ server, ensure you configure Cisco attribute-value (AV) pair privilege level (priv-lvl) for Cisco Integrated Management Controller (CIMC) service for the minimum privilege level of administrators and operators.

In CIMC TACACS configuration, privilege level 14 is assigned to the administrator role, and privilege level 9 is assigned to the operator role. This means a user with privilege level 14 or higher has admin privileges when the user logs into the system, and a user with privilege level 9 or higher has all privileges of an operator at the time of login.

Privilege level below 9 has the read-only privileges.

These two are optional arguments. By default admin-priv is 15 and oper-priv is 11.

To configure a TACACS server on CIMC:

```
Server /# scope tacacs
Server /tacacs# set tacacs-server ip-address
Server /tacacs*# set tacacs-key <keystring>
Server /tacacs*# set tacacs-enable yes
Server /tacacs*# set admin-priv 12
Server /tacacs*# set oper-priv 5
Server /tacacs*# commit
Server /tacacs# show detail
```

To verify the TACACS+ server configuration:

```
Server/tacacs# show detail

tacacs Settings:
  Server domain name or IP address:
  Enable tacacs: yes
  shared-secret key: *****
  admin-priv: 14
  oper-priv: 10
```

For more information about this feature, see [TACACS+ Server](#).

## LTE PIM Module on Cisco Catalyst 8200 UCPE

The LTE PIM modules provide 4G LTE cellular connectivity on the Cisco Catalyst 8200 UCPE platform. The following LTE PIM modules are supported on the Cisco Catalyst 8200 UCPE platform:

- P-LTE-GB
- P-LTE-IN
- P-LTE-US
- P-LTE-VZ
- P-LTEA-EA
- P-LTEA-LA

### Limitations

The following are the limitations when you use LTE PIM modules on Cisco Catalyst 8200 UCPE platform:

- Only one SIM card is supported at a time. If both SIMs are present, SIM in slot 0 is used. To use SIM in slot 1, slot 0 should be empty.
- IPv6 is not supported.

- Only 4G LTE cellular features mentioned in this section are supported on the LTE PIM module on the Cisco Catalyst 8200 UCPE platform.

### Remote Access to Cisco Catalyst 8200 UCPE through LTE PIM Module

Remote access to Cisco Catalyst 8200 UCPE platform through LTE PIM module is supported. This requires users to obtain cellular SIM with static IP address from service providers. After the cellular SIM with static IP address is obtained, you can use remote protocol like SSH to remotely access the Cisco Catalyst 8200 UCPE platform.

```
MacBook:~ $ ssh admin@192.168.100.101
admin@192.168.100.101's password:
```

```
Cisco Network Function Virtualization Infrastructure Software (NFVIS)
```

```
NFVIS Version: 4.4.1-FC2
```

```
Copyright (c) 2015-2020 by Cisco Systems, Inc.
Cisco, Cisco Systems, and Cisco Systems logo are registered trademarks of Cisco
Systems, Inc. and/or its affiliates in the U.S. and certain other countries.
```

```
The copyrights to certain works contained in this software are owned by other
third parties and used and distributed under third party license agreements.
Certain components of this software are licensed under the GNU GPL 2.0, GPL 3.0,
LGPL 2.1, LGPL 3.0 and AGPL 3.0.
```

```
admin connected from 128.168.241.172 using ssh on C8200-NFVIS
C8200-NFVIS#
```

You can also access Cisco Catalyst 8200 UCPE through a portal.

### Show Commands

The following commands are used to display LTE PIM module's information.

The following example shows all cellular information using the **show cellular** command:

```
C8200-NFVIS# show cellular
cellular 1/0
  details IPv4 address =      192.168.100.101
  details Default Gateway Address = 192.168.100.102
  details Interface subnet mask = 255.255.255.252
  details Interface name =   int-CELL-1-0
  details Interface Status = up
  details DNS IP Address =   198.224.173.135
  details Modem Status =    Call_Connected
  hardware Modem Firmware Version =
SWI9X30C_02.33.03.00
  hardware Device Model ID =                               EM7455
  hardware International Mobile Subscriber Identity (IMSI) = 311480148702353
  hardware International Mobile Equipment Identity (IMEI) = 356129070591075
  hardware Integrated Circuit Card ID (ICCID) =
89148000001470156497
  hardware Mobile Subscriber Intergrated Services Digital Network Number (MSISDN) = 4085550087

  hardware Factory Serial Number (FSN) =                   LF911203620410
  hardware Current Modem Temperature =                      37 deg C
```

```

hardware PRI SKU ID = 1102526
hardware PRI Version = 002.079_001
hardware Carrier = VERIZON
hardware OEM PRI Version = 000.016
hardware Modem Status = Modem Online
network Current System Time = 2020/11/15/23/35/12
network Network Selection Mode = AUTO
network Current Service Status = Packet switched
network Mobile Country Code(MCC) = 311
network Mobile Network Code(MNC) = 480
network Current Roaming Status = HOME
network Network = Verizon
network Packet Switch domain(PS) state = Attached
network EMM State = Registered
network EMM Sub state = Normal-Service
network EMM Connection State = 2
network Tracking Area Code (TAC) = 7936
network Cell ID = 7962134
network Network MTU = 1428
radio-details Radio Power Mode = online
radio-details Radio Access Technology(RAT) Preference = AUTO
radio-details Radio Access Technology(RAT) Selected = LTE
radio-details LTE RX Channel Number = 2075
radio-details LTE TX Channel Number = 20075
radio-details LTE Band = 4
radio-details LTE Bandwidth = 15 MHz
radio-details Current RSSI = -73 dBm
radio-details Current RSRP = -103 dBm
radio-details Current RSRQ = -10 dB
radio-details Current SNR = 5 dB
radio-details PCI = 169
Profile 3, Packet Session Status = ACTIVE
Call end mode = None
Session disconnect reason type = None(0)
Session disconnect reason = None(0)
PDN 0
Back off timer is NOT running
Back off error count = 0
Back off timer index = 0
Back off timer array (in minutes) = 0 1 1 1 5 10 15 30 60
Cellular interface back-off is not enforced
Period of back-off = 0 minute(s)
profile-details 1
  PDP-Type IPv4v6
  APN-Name ims
  state INACTIVE
  PDP-Address 0.0.0.0
  Authentication None
  Username
  Password
profile-details 2
  PDP-Type IPv4v6
  APN-Name vzwadmin
  state INACTIVE
  PDP-Address 0.0.0.0
  Authentication None
  Username
  Password
profile-details 3
  PDP-Type IPv4v6
  APN-Name we01.VZWSTATIC
  state ACTIVE
  PDP-Address 192.168.100.101
  Authentication None

```

```

Username
Password
profile-details 4
PDP-Type      IPv4v6
APN-Name      vzwapp
state         INACTIVE
PDP-Address   0.0.0.0
Authentication None
Username
Password
profile-details 5
PDP-Type      IPv4v6
APN-Name      vzw800
state         INACTIVE
PDP-Address   0.0.0.0
Authentication None
Username
Password
profile-details 6
PDP-Type      IPv4v6
APN-Name      vzwclass6
state         INACTIVE
PDP-Address   0.0.0.0
Authentication None
Username
Password
status Firmware Upgrade Status = "Not Initiated"
status DM Logging Status = Stopped
SIM
ID   SIM STATUS
-----
0    OK
1    Not inserted

```

C8200-NFVIS#

The following examples shows the individual cellular information using the **show cellular 1/0 [connection | details | hardware | network | profile-details | radio-details | status]** command:

**connection** : Cellular connection information

```

C8200-NFVIS# show cellular 1/0 connection
Profile 3, Packet Session Status = ACTIVE
Call end mode = None
Session disconnect reason type = None(0)
Session disconnect reason = None(0)
PDN 0
Back off timer is NOT running
Back off error count = 0
Back off timer index = 0
Back off timer array (in minutes) = 0 1 1 1 5 10 15 30 60
Cellular interface back-off is not enforced
Period of back-off = 0 minute(s)
C8200-NFVIS#

```

**details** : Cellular basic information

```

C8200-NFVIS# show cellular 1/0 details
details IPv4 address = 192.168.100.101
details Default Gateway Address = 192.168.100.102
details Interface subnet mask = 255.255.255.252
details Interface name = int-CELL-1-0
details Interface Status = up

```

```

details DNS IP Address = 198.224.173.135
details Modem Status = Call_Connected
C8200-NFVIS#

```

### hardware : Cellular hardware information

```

C8200-NFVIS# show cellular 1/0 hardware
hardware Modem Firmware Version = SWI9X30C_02.33.03.00
hardware Device Model ID = EM7455
hardware International Mobile Subscriber Identity(IMSI) = 311480148702353
hardware International Mobile Equipment Identity (IMEI) = 356129070591075
hardware Integrated Circuit Card ID (ICCID) = 8914800001470156497
hardware Mobile Subscriber Intergrated Services Digital Network Number (MSISDN) = 4085550087
hardware Factory Serial Number (FSN) = LF911203620410
hardware Current Modem Temperature = 37 deg C
hardware PRI SKU ID = 1102526
hardware PRI Version = 002.079_001
hardware Carrier = VERIZON
hardware OEM PRI Version = 000.016
hardware Modem Status = Modem Online
C8200-NFVIS#

```

### network : Cellular network information

```

C8200-NFVIS#
C8200-NFVIS# show cellular 1/0 network
network Current System Time = 2020/11/15/23/39/52
network Network Selection Mode = AUTO
network Current Service Status = Packet switched
network Mobile Country Code(MCC) = 311
network Mobile Network Code(MNC) = 480
network Current Roaming Status = HOME
network Network = Verizon
network Packet Switch domain(PS) state = Attached
network EMM State = Registered
network EMM Sub state = Normal-Service
network EMM Connection State = 2
network Tracking Area Code (TAC) = 7936
network Cell ID = 7962134
network Network MTU = 1428
C8200-NFVIS#

```

### profile-details : Cellular profile details

```

C8200-NFVIS# show cellular 1/0 profile-details
profile-details 1
PDP-Type IPv4v6
APN-Name ims
state INACTIVE
PDP-Address 0.0.0.0
Authentication None
Username
Password
profile-details 2
PDP-Type IPv4v6
APN-Name vzwadmin
state INACTIVE
PDP-Address 0.0.0.0
Authentication None
Username

```

```

Password
profile-details 3
PDP-Type      IPv4v6
APN-Name      we01.VZWSTATIC
state         ACTIVE
PDP-Address   192.168.100.101
Authentication None
Username
Password
profile-details 4
PDP-Type      IPv4v6
APN-Name      vzwapp
state         INACTIVE
PDP-Address   0.0.0.0
Authentication None
Username
Password
profile-details 5
PDP-Type      IPv4v6
APN-Name      vzw800
state         INACTIVE
PDP-Address   0.0.0.0
Authentication None
Username
Password
profile-details 6
PDP-Type      IPv4v6
APN-Name      vzwclass6
state         INACTIVE
PDP-Address   0.0.0.0
Authentication None
Username
Password
C8200-NFVIS#

```

#### **radio-details** : Cellular radio details

```

C8200-NFVIS# show cellular 1/0 radio-details
radio-details Radio Power Mode =          online
radio-details Radio Access Technology(RAT) Preference =  AUTO
radio-details Radio Access Technology(RAT) Selected =  LTE
radio-details LTE RX Channel Number =     2075
radio-details LTE TX Channel Number =     20075
radio-details LTE Band =                  4
radio-details LTE Bandwidth =              15 MHz
radio-details Current RSSI =              -72 dBm
radio-details Current RSRP =              -103 dBm
radio-details Current RSRQ =              -17 dB
radio-details Current SNR =                7 dB
radio-details PCI =                       169
C8200-NFVIS#
C8200-NFVIS#

```

#### **status** : Cellular status details

```

C8200-NFVIS# show cellular 1/0 status
status Firmware Upgrade Status = "Not Initiated"
status DM Logging Status = Stopped
SIM
ID  SIM STATUS
-----
0   OK
1   Not inserted

```

```
C8200-NFVIS#
```

The following example shows the Tx and Rx information on the LTE PIM module using the **show bridge-settings cellular-br** command:

```
C8200-NFVIS# show bridge-settings cellular-br
bridge-settings cellular-br
 ip-info interface cellular-br
 ip-info ipv4_address 192.168.100.101
 ip-info netmask 255.255.255.252
 ip-info link-local ipv6 address fe80::7c88:e1ff:de8c:bbc5
 ip-info link-local ipv6 prefixlen 64
 ip-info global ipv6 address ::
 ip-info global ipv6 prefixlen 0
 ip-info mac_address 6f:82:d1:8e:bf:5c
 ip-info mtu 1428
 ip-info txqueuelen 1000
 stats rx_packets 13295
 stats rx_bytes 979420
 stats rx_errors 0
 stats rx_dropped 0
 stats rx_overruns 0
 stats rx_frame 0
 stats tx_packets 11529
 stats tx_bytes 8147515
 stats tx_errors 0
 stats tx_dropped 0
 stats tx_overruns 0
 stats tx_carrier 0
 stats tx_collisions 0
 vlan tag untagged
 dhcp disabled
 dhcp-ipv6 disabled
 slaac-ipv6 disabled
 dpdk-enabled false
C8200-NFVIS#
```

The following example shows how to verify the available PIM module:

```
C8200-UCPE-1N8# show chassis compute inventory pim-modules
POWER
SLOT/BAY/PORT PID TYPE DESCRIPTION STATUS
-----
0/1/0 P-LTE-US 0x4a10 - on
```

```
C8200-UCPE-1N8#
C8200-UCPE-1N8# show chassis
chassis serial FOC241106RG
chassis pid C8200-UCPE-1N8
chassis uuid 4ce1767c-05d0-0000-2903-0f0f000a0b05
chassis bios-version C8200-UCPE_1.0.040920201359
chassis hardware-version V01
chassis compute inventory cpu units CPU0
vendor "Intel(R) Corporation"
family "Pentium 4"
thread-count 8
version "Intel(R) Atom(TM) CPU C3758 @ 2.20GHz"
speed 2200
core-count 8
status "Populated, Enabled"
signature "Type 0, Family 6, Model 95, Stepping 1"
chassis compute inventory memory units DIMM0 "BANK 0"
```

```

capacity 8192
channel-speed 2666
channel-type DDR4
type-detail "Synchronous Registered (Buffered)"
manufacturer "SK Hynix"
serial 434263FD
asset-tag "BANK 0 DIMM0 AssetTag"
part-number HMA81GR7CJR8N-VK
data-width 72
chassis compute inventory memory units DIMM1 "BANK 0"
manufacturer "NO DIMM"
serial "NO DIMM"
asset-tag "NO DIMM"
part-number "NO DIMM"
VENDOR MODEL CAPACITY
-----
CISCO eMMC HS-SD/MMC 31.79
ATA SAMSUNG MZ7LH3T8 3840.76

POWER
SLOT/BAY/PORT PID TYPE DESCRIPTION STATUS
-----
0/1/0 P-LTE-US 0x4a10 - on

MAX PRODUCT
INPUT OUTPUT ID
-----
100 90 -

C8200-UCPE-1N8#

```

### Verifying LTE PIM Module Network Connectivity

After Cisco Catalyst 8200 UCPE boots up with a supported LTE PIM and a carrier SIM card, you can verify if the LTE PIM module is connected to the carrier network using the **show cellular 1/0 details** command.

The following example shows how to verify if the LTE PIM module is connected:

```

C8200-NFVIS# show cellular 1/0 details
details IPv4 address = 101.144.109.57 <-- IP address obtained
details Default Gateway Address = 101.144.109.58
details Interface subnet mask = 255.255.255.252
details Interface name = int-CELL-1-0
details Interface Status = up
details DNS IP Address = 101.224.173.135
details Modem Status = Call_Connected <-- Cellular call connected
C8200-NFVIS#

```

For a successful network connection:

1. The LTE PIM module should be able to obtain an IP address.
  - Example here is 101.144.109.57.
  - If the SIM card has a dynamic IP address, this IP address would change over time. This works the same way as dynamic IP address assignment with wired network.
2. Modem status should show as **Call\_Connected**.
3. Ping to any public IP network should be successful (8.8.8.8).

If any of the above are incorrect, see the troubleshooting section below.

## LTE PIM Module LED

For information on LTE PIM module's LED colors and behaviors, see [LTE LED Details](#).

## Online Insertion and Removal (OIR) of LTE PIM Module

You can replace the LTE PIM module without affecting the Cisco Catalyst 8200 UCPE platform system operations with the online insertion and removal (OIR) operation. OIR commands are issued before removing and after installing an LTE PIM. When you perform OIR, use an identical or another variation of LTE PIM module to replace the original one.

### Command

**chassis compute inventory pim-modules units 0/1/0 [reload | start | stop]**



**Note** Removing the LTE PIM module without executing the **chassis compute inventory pim-modules units 0/1/0 stop** command is not supported.

### Examples

```
C8200-NFVIS#
C8200-NFVIS# chassis compute inventory pim-modules units 0/1/0 stop
Are you sure you want to stop this module? [no,yes] yes
C8200-NFVIS#
C8200-NFVIS#
C8200-NFVIS# show cellular 1/0 details
details IPv4 address =      0.0.0.0
details Default Gateway Address =  0.0.0.0
details Interface subnet mask =  0.0.0.0
details Interface name =  int-CELL-1-0
details Interface Status =  down
details DNS IP Address =  0.0.0.0
details Modem Status =      Disconnected
C8200-NFVIS#
C8200-NFVIS#
C8200-NFVIS# show chassis | begin SLOT
SLOT/BAY/PORT  PRODUCT ID  SERIAL  REVISION  NUMBER  MAC ADDRESS
-----
0/2/0          NIM-LTEA-EA  -      0x1      -      00:5d:73:48:e4:80

SLOT/BAY/PORT  PID        TYPE    DESCRIPTION  POWER
-----
0/1/0          P-LTEA-EA  0x4710  -            off

          MAX    PRODUCT
INPUT  OUTPUT  ID
-----
100    90      -

C8200-NFVIS#

C8200-NFVIS# chassis compute inventory pim-modules units 0/1/0 start
Are you sure you want to start this module? [no,yes] yes
C8200-NFVIS#
C8200-NFVIS#
C8200-NFVIS# show cellular 1/0 details
details IPv4 address =      192.168.100.101
```

```

details Default Gateway Address = 192.168.100.102
details Interface subnet mask = 255.255.255.252
details Interface name = int-CELL-1-0
details Interface Status = up
details DNS IP Address = 198.224.173.135
details Modem Status = Call_Connected
C8200-NFVIS#
C8200-NFVIS#
C8200-NFVIS# show chassis | begin SLOT
SLOT/BAY/PORT  PRODUCT ID  SERIAL  REVISION  NUMBER  MAC ADDRESS
-----
0/2/0          NIM-LTEA-EA  -       0x1       -       00:5d:73:48:e4:80

SLOT/BAY/PORT  PID          TYPE      DESCRIPTION  POWER
-----
0/1/0          P-LTEA-EA   0x4710   -           on

          MAX      PRODUCT
INPUT  OUTPUT  ID
-----
100    90     -

C8200-NFVIS#

```

### Turning LTE PIM Module's Radio On/Off

The following examples show how to turn the LTE PIM's radio off or on using the **cellular 1/0 modem-radio-off** and **cellular 1/0 modem-radio-on** commands:

```

C8200-NFVIS#
C8200-NFVIS# cellular 1/0 modem-radio-off
C8200-NFVIS#
C8200-NFVIS# show cellular 1/0 radio-details
radio-details Radio Power Mode = offline
radio-details Offline Reason = None
radio-details Radio Access Technology(RAT) Preference = AUTO
radio-details Radio Access Technology(RAT) Selected = AUTO
radio-details Current RSSI = -128 dBm
radio-details Channel-Number = 0
radio-details Band = Unknown
radio-details ECI0 = -2 dBm
C8200-NFVIS#

```

```

C8200-NFVIS# cellular 1/0 modem-radio-on
C8200-NFVIS#
C8200-NFVIS# show cellular 1/0 radio-details
radio-details Radio Power Mode = online
radio-details Radio Access Technology(RAT) Preference = AUTO
radio-details Radio Access Technology(RAT) Selected = LTE
radio-details LTE RX Channel Number = 2075
radio-details LTE TX Channel Number = 20075
radio-details LTE Band = 4
radio-details LTE Bandwidth = 15 MHz
radio-details Current RSSI = -76 dBm
radio-details Current RSRP = -106 dBm
radio-details Current RSRQ = -15 dB
radio-details Current SNR = 8 dB
radio-details PCI = 169
C8200-NFVIS#

```

## Resetting Modem on the LTE PIM Module

The following example shows how to reset the LTE PIM's modem using the **cellular 1/0 modem-reset** command:

```

C8200-NFVIS#
C8200-NFVIS# show cellular 1/0 hardware
hardware Modem Firmware Version = SWI9X30C_02.33.03.00
hardware Device Model ID = EM7455
hardware International Mobile Subscriber Identity(IMSI) = 311480148702353
hardware International Mobile Equipment Identity (IMEI) = 356129070591075
hardware Integrated Circuit Card ID (ICCID) = 8914800001470156497
hardware Mobile Subscriber Intergrated Services Digital Network Number (MSISDN) = 4083180087
hardware Factory Serial Number (FSN) = LF911203620410
hardware Current Modem Temperature = 36 deg C
hardware PRI SKU ID = 1102526
hardware PRI Version = 002.079_001
hardware Carrier = VERIZON
hardware OEM PRI Version = 000.016
hardware Modem Status = Modem Online
C8200-NFVIS#
C8200-NFVIS#
C8200-NFVIS#
C8200-NFVIS# cellular 1/0 modem-reset
C8200-NFVIS#
C8200-NFVIS#
C8200-NFVIS# show cellular 1/0 hardware
hardware Modem Firmware Version = None
hardware Device Model ID = None
hardware International Mobile Subscriber Identity(IMSI) = None
hardware International Mobile Equipment Identity (IMEI) = None
hardware Integrated Circuit Card ID (ICCID) = None
hardware Mobile Subscriber Intergrated Services Digital Network Number (MSISDN) = None
hardware Factory Serial Number (FSN) = None
hardware Current Modem Temperature = None
hardware PRI SKU ID = None
hardware PRI Version = None
hardware Carrier = None
hardware OEM PRI Version = None
hardware Modem Status = None <-- modem
is down
C8200-NFVIS#
C8200-NFVIS#
C8200-NFVIS# show cellular 1/0 hardware
hardware Modem Firmware Version = SWI9X30C_02.33.03.00
hardware Device Model ID = EM7455
hardware International Mobile Subscriber Identity(IMSI) = 311480148702353
hardware International Mobile Equipment Identity (IMEI) = 356129070591075
hardware Integrated Circuit Card ID (ICCID) = 8914800001470156497
hardware Mobile Subscriber Intergrated Services Digital Network Number (MSISDN) = 4083180087
hardware Factory Serial Number (FSN) = LF911203620410
hardware Current Modem Temperature = 36 deg C
hardware PRI SKU ID = 1102526
hardware PRI Version = 002.079_001
hardware Carrier = VERIZON
hardware OEM PRI Version = 000.016
hardware Modem Status = Modem Online <--
modem back up
C8200-NFVIS#

```

## Modifying Profile on the LTE PIM Module

The following examples show how to create and delete LTE PIM's cellular profile using the **cellular profile create [apn-name | authentication | interface-id | pdp-type | profile-id]** and **cellular profile delete [apn-name | authentication | interface-id | pdp-type | profile-id]** commands:

```
C8200-NFVIS# show cellular 1/0 profile-details | begin "profile-details 7"
C8200-NFVIS# <-- cellular profile does not exist
C8200-NFVIS#
C8200-NFVIS# cellular profile create apn-name test-apn authentication None interface-id 1/0
pdp-type IPv4 profile-id 7
resp Profile Management Cmd Executed successfully
C8200-NFVIS#
C8200-NFVIS#
C8200-NFVIS# show cellular 1/0 profile-details | begin "profile-details 7"
profile-details 7 <-- profile created
PDP-Type      IPv4
APN-Name      test-apn
state         INACTIVE
PDP-Address   0.0.0.0
Authentication None
Username
Password
C8200-NFVIS#
C8200-NFVIS#
C8200-NFVIS# cellular profile delete apn-name test-apn authentication None interface-id 1/0
pdp-type IPv4 profile-id 7
resp Profile Management Cmd Executed successfully
C8200-NFVIS#
C8200-NFVIS#
C8200-NFVIS# show cellular 1/0 profile-details | begin "profile-details 7"
C8200-NFVIS# <-- profile deleted
C8200-NFVIS#
```

## DM Log Collection on LTE PIM Module

Diagnostic Monitor (DM) is a Qualcomm proprietary protocol. Diagnostic software tools, such as Sierra Wireless SwiLog and Qualcomm QXDM, are based on DM protocol. These tools can be used to capture data transactions between the modem and the network over the RF interface, which makes them useful tools for troubleshooting 3G and 4G data connectivity or performance issues.

### To start DM log collection

The following example shows how to start DM log collection using the **dm-log enable** command:

```
C8200-NFVIS# config terminal
Entering configuration mode terminal
C8200-NFVIS(config)# controller cellular 1/0
C8200-NFVIS(config-cellular-1/0)# dm-log enable
C8200-NFVIS(config-cellular-1/0)# commit
Commit complete.
C8200-NFVIS(config-cellular-1/0)# end
C8200-NFVIS#
```



---

**Note** DM log rotation is enabled by default.

---

### To stop DM log collection

The following example shows how to stop DM log collection using the **no dm-log enable** command:

```

C8200-NFVIS# config terminal
Entering configuration mode terminal
C8200-NFVIS(config)# controller cellular 1/0
C8200-NFVIS(config-cellular-1/0)# no dm-log enable
C8200-NFVIS(config-cellular-1/0)# commit
Commit complete.
C8200-NFVIS(config-cellular-1/0)# end
C8200-NFVIS#

```

### To view DM log collection status

The following example shows how to view the status of DM log collection using the **show cellular 1/0 status** command:

```

C8200-NFVIS# show cellular 1/0 status
status Firmware Upgrade Status = "Not Initiated"
status DM Logging Status = Started <-- DM log enabled
SIM
ID   SIM STATUS
-----
0    OK
1    Not inserted

C8200-NFVIS#

C8200-NFVIS# show cellular 1/0 status
status Firmware Upgrade Status = "Not Initiated"
status DM Logging Status = Stopped <-- DM log not enabled
SIM
ID   SIM STATUS
-----
0    OK
1    Not inserted

C8200-NFVIS#

```

### To retrieve the collected DM log file

Download the system's tech-support file.

### To configure DM log non-default filter

- SCP the DM log filter onto C8200-UCPE-1N8.

```
scp <username>@<server_ip>:<dm_log_filter_file> intdatastore:<dm_log_filter_file>
```

Example:

```
scp admin@192.19.145.241:/home/gpsmask.sqf intdatastore:gpsmask.sqf
```

- Configure specific DM log filter.

```
dm-log filter-path /data/intdatastore/uploads/<dm_log_filter_file>
```



**Note** To enable DM log collection with DM log filter, need to issue “commit” twice:

1st time: after configure DM log filter

2nd time: after enable DM log collection

Example:

```

C8200-NFVIS# config terminal
  Entering configuration mode terminal
C8200-NFVIS(config)# controller cellular 1/0
C8200-NFVIS(config-cellular-1/0)# dm-log filter-path
/data/intdatastore/uploads/gpsmask.sqf
C8200-NFVIS(config-cellular-1/0)# commit <-- need to execute before enable DM log
Commit complete.
C8200-NFVIS(config-cellular-1/0)#
C8200-NFVIS(config-cellular-1/0)# dm-log enable
C8200-NFVIS(config-cellular-1/0)# commit <-- need to execute again
Commit complete.
C8200-NFVIS(config-cellular-1/0)# end
C8200-NFVIS#

```



---

**Note** When you use an invalid filter or mistype the filter's name, a DM log file of 0 byte size will be created.

---

### To remove DM log filter

The following example shows how to remove DM log filter using the **no dm-log filter-path** command:

```

C8200-NFVIS# config term
  Entering configuration mode terminal
C8200-NFVIS(config)# controller cellular 1/0
C8200-NFVIS(config-cellular-1/0)# no dm-log filter-path
C8200-NFVIS(config-cellular-1/0)# commit
Commit complete.
C8200-NFVIS(config-cellular-1/0)# end
C8200-NFVIS#

```

### Firmware Upgrade LTE PIM Module's Modem

From time to time, the LTE PIM's modem requires firmware upgrade to obtain fixes for cellular modem's issues. Firmware upgrade on the LTE PIM module can be done with the following procedure.

1. Obtain firmware and/or OEM PRI files and put them into a server the C8200-UCPE-1N8 can SCP from.



---

**Note** You can find the latest firmware files at <https://www.cisco.com/c/en/us/support/interfaces-modules/lte-wireless-wan-interfaces/series.html>

---



---

**Caution** Use only Cisco certified firmware. Using a firmware version not certified by Cisco may impact the wireless service provider network adversely.

---

2. SCP the firmware or OEM PRI files from the external source to /data/intdatastore/uploads folder of the C8200-UCPE-1N8.

```
scp <username>@<server_ip>:<fw_file> intdatastore:<fw_file>
```

Example:

```
scp admin@192.19.145.241:/fw_folder/WP76xx_02.28.03.01_ATT_002.071_000.spk
intdatastore:wp7603_02.28.03.01_ATT.spk
```

3. Firmware upgrade the LTE PIM's modem.

cellular 1/0 upgrade-firmware path /data/intdatastore/uploads/



---

**Note**

- Firmware upgrade process will take up to 15 minutes. During this time the modem will be unusable. Please do not remove power or reload the C8200-UCPE-1N8 during the firmware upgrade process.
  - Firmware upgrade status can be seen with **show cellular 1/0 status** command.
- 

4. Delete the firmware or OEM PRI files from the /data/intdatastore/uploads folder of the C8200-UCPE-1N8.

system file-delete file name /data/intdatastore/uploads/<fw\_file>



---

**Note**

- There can only be 1 firmware/OEM PRI file in the /data/intdatastore/uploads folder for each firmware upgrade process.
  - For EM74xx modems' firmware upgrade, only have 1 .CWE and 1 .NVU files in the folder.
  - For WP76xx modems' firmware upgrade, only have 1 .SPK file in the folder.
  - For EM74xx modems' and WP76xx modems' OEM PRI upgrade, only have 1 .NVU file in the folder.
- 

### Enabling Debug to Troubleshooting LTE PIM Module

Enable debugs to troubleshoot cellular issues can be done with the following procedures:

1. Find out the current system logging level.

**show system logging-level**

```
C8200-NFVIS# show system logging-level
system logging-level configuration info
system logging-level operational warning
C8200-NFVIS#
```

2. Set logging level for both configuration and operational to debug.

**system set-log level debug logtype all**

```
C8200-NFVIS# system set-log level debug logtype all
C8200-NFVIS#
C8200-NFVIS# show system logging-level
system logging-level configuration debug
system logging-level operational debug
C8200-NFVIS#
```

3. Enable debug for cellular logging traces.

**cellular debug eng-mode mode enable**

```
C8200-NFVIS#
C8200-NFVIS# cellular debug eng-mode mode enable
C8200-NFVIS#
```

4. Disable debug for cellular logging traces.

**cellular debug eng-mode mode disable**

```
C8200-NFVIS#
C8200-NFVIS# cellular debug eng-mode mode disable
C8200-NFVIS#
```

**5. Put system logging level back**

**system set-log level <critical | debug | error | info | warning> logtype <all | configuration | operational>**

```
C8200-NFVIS#
C8200-NFVIS# system set-log level info logtype configuration
C8200-NFVIS# system set-log level warning logtype operational
C8200-NFVIS#
C8200-NFVIS# show system logging-level
system logging-level configuration info
system logging-level operational warning
C8200-NFVIS#
```

**To retrieve the debug log file**

Download the system tech-support file.

**Troubleshooting**

Check the following use cases if the LTE PIM does not have cellular network connectivity:

- Verify that the LTE PIM module is inserted and recognized by the Cisco Catalyst 8200 UCPE. The following example shows how to verify the same using the command **show chassis** command:

```
C8200-NFVIS# show chassis
chassis serial FGL2352LLC8
chassis pid C8200-UCPE-1N8
chassis uuid 4c710d27-b960-0000-2903-0f0f000a0b05
chassis bios-version C8200-UCPE_1.01.042820201140
chassis hardware-version V01
chassis compute inventory cpu units CPU0
vendor "Intel(R) Corporation"
family "Pentium 4"
thread-count 8
version "Intel(R) Atom(TM) CPU C3758 @ 2.20GHz"
speed 2200
core-count 8
status "Populated, Enabled"
signature "Type 0, Family 6, Model 95, Stepping 1"
chassis compute inventory memory units DIMM0 "BANK 0"
capacity 8192
channel-speed 2666
channel-type DDR4
type-detail "Synchronous Registered (Buffered)"
manufacturer Smart
serial 30304754
asset-tag "BANK 0 DIMM0 AssetTag"
part-number SR5721G812APGDAME2
data-width 72
chassis compute inventory memory units DIMM1 "BANK 0"
manufacturer "NO DIMM"
serial "NO DIMM"
asset-tag "NO DIMM"
part-number "NO DIMM"
VENDOR MODEL CAPACITY
-----
```

```
CISCO eMMC HS-SD/MMC 31.79
```

SLOT/BAY/PORT	PRODUCT ID	SERIAL	HARDWARE REVISION	PART NUMBER	MAC ADDRESS
0/2/0	NIM-LTEA-EA	-	0x1	-	00:5d:73:48:e4:80

SLOT/BAY/PORT	PID	TYPE	DESCRIPTION	POWER STATUS
0/1/0	P-LTEA-EA	0x4710	-	on <--- LTE PIM module is recognized and power on.

INPUT	MAX OUTPUT	PRODUCT ID
100	90	-

```
C8200-NFVIS#
```

If the LTE PIM module is not recognized, try to reinsert the LTE PIM module.

- Verify if the SIM card is detected by the LTE PIM module. The following example shows how to verify the same using the **show cellular 1/0 status** command:

```
C8200-NFVIS# show cellular 1/0 status
status Firmware Upgrade Status = "Not Initiated"
status DM Logging Status = Stopped
SIM
ID  SIM STATUS
-----
0   OK          <-- SIM card is detected.
1   Not inserted
```

```
C8200-NFVIS#
```

If the SIM card is not detected, perform OIR of the LTE PIM module and re-seat the SIM card.

- Verify if the LTE PIM module is attached to the cellular network. The following example shows how to verify the same using the **show cellular 1/0 network** command:

```
C8200-NFVIS# show cellular 1/0 network
network Current System Time = 2020/12/20/6/56/2
network Network Selection Mode = AUTO
network Current Service Status = Packet switched
network Mobile Country Code(MCC) = 311
network Mobile Network Code(MNC) = 480
network Current Roaming Status = HOME
network Network = Verizon
network Packet Switch domain(PS) state = Attached <-- LTE PIM module is attached to
the Verizon network.
network EMM State = Registered
network EMM Sub state = Normal-Service
network EMM Connection State = 2
network Tracking Area Code (TAC) = 7936
network Cell ID = 7967246
network Network MTU = 1428
C8200-NFVIS#
```

If the LTE PIM module is not attached to the cellular network, continue on to the next bullet.

- Verify the LTE module has cellular signal or reception. The following example shows how to verify the same using the **show cellular 1/0 radio-details** command:

```
C8200-NFVIS# show cellular 1/0 radio-details
radio-details Radio Power Mode =          online
radio-details Radio Access Technology(RAT) Preference =  AUTO
radio-details Radio Access Technology(RAT) Selected =  LTE
radio-details LTE RX Channel Number =     2075
radio-details LTE TX Channel Number =     20075
radio-details LTE Band =                  4
radio-details LTE Bandwidth =             15 MHz
radio-details Current RSSI =              -71 dBm
radio-details Current RSRP =              -105 dBm
radio-details Current RSRQ =              -11 dB
radio-details Current SNR =               7 dB
radio-details PCI =                       169
C8200-NFVIS#
```

**Table 10: Reference Radio Signal Quality**

	RSSI (dBm)	RSRP (dBm)	RSRQ (dB)	SNR (dB)
Excellent	> -65	> -84	> -5	> 12.5
Good	-65 to -75	-85 to -102	-9 to -5	10 to 12.5
Fair	-75 to -85	-103 to -111	-12 to -9	7 to 10
Poor	< -85	< -111	< -12	< 7

- RSSI – Represents the entire received power including the wanted power from the serving cell as well as all co-channel power and other sources of noise.
- RSRP – The average power received from a single reference signal and its typical range is around -44dbm (good) to -140dbm(bad).
- RSRQ – Indicates quality of the received signal and its range is typically -19.5dB(bad) to -3dB (good).
- SNR – The signal-to-noise ratio of the given signal

If the cellular signal or reception is not good, try to place the cellular antenna at a location where it can pick up good signal or reception.

- Verify the LTE module has correct cellular profile configuration. The following example shows how to verify the same using the **show cellular 1/0 profile-details** command:

```
C8200-NFVIS# show cellular 1/0 profile-details
profile-details 1
PDP-Type      IPv4v6
APN-Name      ims
state         INACTIVE
PDP-Address   0.0.0.0
Authentication None
Username
Password
profile-details 2
PDP-Type      IPv4v6
```

```

APN-Name      vzwadmin
state        INACTIVE
PDP-Address  0.0.0.0
Authentication None
Username
Password
profile-details 3
PDP-Type     IPv4v6
APN-Name     we01.VZWSTATIC
state       ACTIVE
PDP-Address  101.144.109.57
Authentication None
Username
Password
profile-details 4
PDP-Type     IPv4v6
APN-Name     vzwapp
state       INACTIVE
PDP-Address  0.0.0.0
Authentication None
Username
Password
profile-details 5
PDP-Type     IPv4v6
APN-Name     vzw800
state       INACTIVE
PDP-Address  0.0.0.0
Authentication None
Username
Password
profile-details 6
PDP-Type     IPv4v6
APN-Name     vzwclass6
state       INACTIVE
PDP-Address  0.0.0.0
Authentication None
Username
Password
C8200-NFVIS#

```

Before you configure, check with your cellular network carrier for the correct values.

- Verify cellular back-off feature is running or not. When this feature is running, it means that the LTE PIM module is performing necessary back-off operations in order to work smoothly with the provider network. The network provider side initiates this back-off request and the reason for such action depends on the code.

The following example shows how to verify if the LTE PIM module's cellular back-off feature is running or not, use the **show cellular 1/0 connection** command:

```

C8200-NFVIS# show cellular 1/0 connection
Profile 3, Packet Session Status = ACTIVE
Call end mode = None
Session disconnect reason type = None(0)
Session disconnect reason = None(0)
PDN 0
Back off timer is NOT running <-- cellular back-off feature is not running
Back off error count = 0
Back off timer index = 0
Back off timer array (in minutes) = 0 1 1 5 10 15 30 60
Cellular interface back-off is not enforced
Period of back-off = 0 minute(s)
C8200-NFVIS#

```

If the LTE PIM module has cellular back-off feature running, verify that the cellular profile is configured correctly. If it is configured correctly and you continue to see cellular back-off feature running, check with your cellular network carrier for the reason of back-off.

For more information on cellular back-off feature, see [Cellular Back-Off](#).

- Verify that there is a routing table for LTE PIM module's cellular interface or cellular-br. The following example shows how to verify the same using the **support show router** command:

```
C8200-NFVIS# support show route
default via 101.144.109.58 dev cellular-br metric 10 <--- default route is through the
cellular-br
10.20.0.0/24 dev int-mgmt-net-br proto kernel scope link src 10.20.0.1
166.144.109.56/30 dev cellular-br proto kernel scope link src 166.144.109.57
192.168.1.0/24 dev lan-br proto kernel scope link src 192.168.1.1
192.168.10.0/24 dev csxbr proto kernel scope link src 192.168.10.11
C8200-NFVIS#
```

If there are multiple default routes, ensure that the cellular-br metric is lower than the other default route.

- Troubleshooting your LTE PIM for cellular network connectivity can also be done through the LEDs located at the front of the LTE PIM module. For more information on the LED behaviors, see [4G LTE-Advanced LEDs](#).

## Datapath Over LTE Cellular Interface on Cisco Catalyst 8200 UCPE

### Information About Datapath Over LTE Cellular Interface on Cisco Catalyst 8200 UCPE

The Cisco Catalyst 8200 UCPE platform includes a slot for a Pluggable Interface Module (PIM) that supports LTE cellular connectivity capabilities. This cellular interface is used to establish control connections and to send VM data traffic and is identified as **cellular-br** for control connections and **cell-data-br** for VM data traffic.

#### Control Connection via Cellular Interface

Starting from Cisco Catalyst SD-WAN Manager Release 20.16.1, to establish a control connection between the Cisco Catalyst 8200 UCPE and Cisco SD-WAN Manager via the cellular interface, the **cellular-br** interface must be configured as a VPN interface. When the vDaemon service is initiated through Plug and Play (PnP), NFVIS automatically adds **cellular-br** as a VPN interface. However, if the vDaemon service is started manually using the **hostaction vdaemon-start** command, manually add the **cellular-br** interface under VPN.

#### VM Data Traffic via Cellular Interface

VMs running on the NFVIS platform can send and receive data through an LTE cellular interface, allowing them to connect to the internet via the cellular network as an alternative to wired connections. This is accomplished by creating a new system-default bridge (**cell-data-br**) and network (**cell-data-net**) on NFVIS, which VMs can use for cellular data transfer.

- **cell-data-net**: This is the network created on NFVIS that VMs can connect to for cellular data transfer. It provides the necessary network configuration for VMs to use the LTE cellular interface for data traffic.
- **cell-data-br**: This is the bridge created on NFVIS that facilitates the connection of VM data traffic to the LTE cellular interface. It acts as the interface through which VMs send and receive data via the cellular network.

**Figure 3: Overview of Cellular Interfaces**

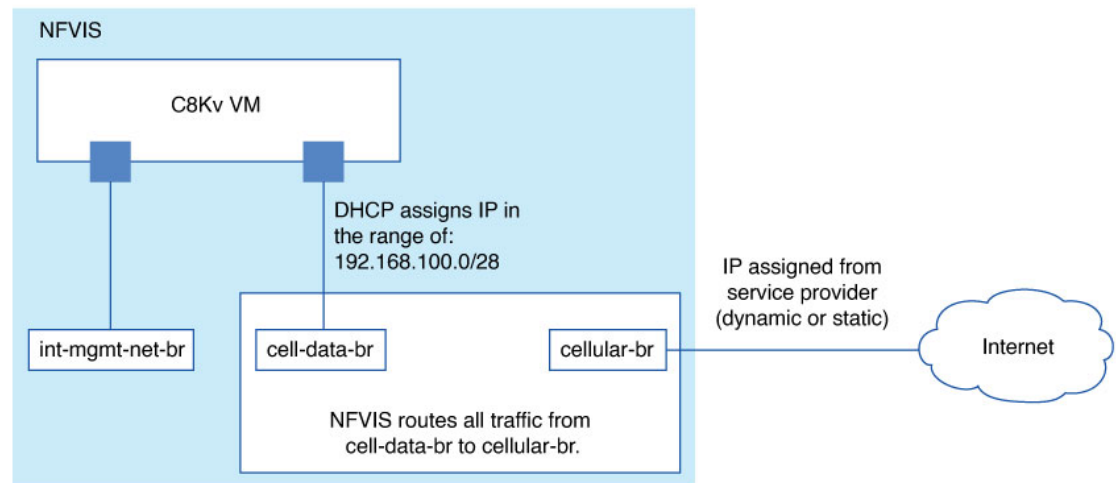

For VMs deployed on NFVIS to utilize cellular data, they must connect to **cell-data-br**. NFVIS automatically assigns an IP address to the VM's interface using DHCP. Internally, NFVIS reroutes traffic over **cell-data-br**, which is the interface on the NFVIS host that receives its IP address from the cellular service provider.

## Benefits of Datapath Over LTE Cellular Interface on Cisco Catalyst 8200 UCPE

- **Enhanced Connectivity**: Enables VMs to use the cellular interface for data transmission, providing an alternative to traditional WAN interfaces.
- **Failover Support**: Provides a failover mechanism to the cellular interface for control connection only when the WAN interface is down or disconnected.
- **Zero Touch Provisioning (ZTP)**: Allows NFVIS to establish control connections via the cellular interface without manual configuration.

## Configure Datapath Over LTE Cellular Interface on Cisco Catalyst 8200 UCPE

### Control Connections via Cellular

Control connection via the cellular interface (**cellular-br**) are automatically detected and configured by NFVIS.

### VM Data Traffic via Cellular

To configure the VM's interface to use the cellular interface follow these steps:

1. Verify the default bridge/network.

Use the command **show running-config bridges bridge cell-data-br** to verify that the default bridge and network exist.

2. Configure VM's Network Interface.

When deploying a VM, configure the VM's network interface to connect to **cell-data-net**. This configuration enables the VM data traffic to be sent via the cellular network.

For more information about deploying VMs or configuring the VM's network, see [VM Life Cycle Management](#).

## Verify Datapath Over LTE Cellular Interface on Cisco Catalyst 8200 UCPE

### Verify Control Connections via Cellular

The following is a sample output from the `show control connections` command. This command provides details about the control connections on the Cisco Catalyst 8200 UCPE, specifically highlighting the active control connections between the device and the Cisco SD-WAN Manager.

```
Device# show control connections
PEER
CONTROLLER
PEER
PRIV
PEER PEER PEER SITE DOMAIN PEER
GROUP PUB
TYPE PROT SYSTEM IP ID ID PRIVATE IP PORT ORGANIZATION LOCAL COLOR
PUBLIC IP
PROXY STATE UPTIME ID
-----
vmanage dtls 192.0.2.22 200 0 192.0.2.29 12346 tohofman Org blue 12346
192.0.2.29 12346 tohofman Org blue No
up 0:00:02:13 0
```

The following is a sample output from the `show cellular 1/0 details` command. This command provides comprehensive information about the cellular interface on the Cisco Catalyst 8200 UCPE, specifically detailing the status, configuration, and operational parameters of the cellular interface identified as 1/0.

```
Device# show cellular 1/0 details
details IPv4 address = 192.0.2.101
details Default Gateway Address = 192.0.2.102
details Interface subnet mask = 255.255.255.240
details Interface name = int-CELL-1-0
details Interface Status = up
details DNS IP Address = 203.0.113.135
details Modem Status = Call_Connected
```

For more information about cellular commands, see [LTE PIM Module on Cisco Catalyst 8200 UCPE](#).

### Verify VM Data Traffic via Cellular

The following is a sample output from the `show running-config bridges bridge cell-data-br` command. This command provides current running configuration of the bridge identified as **cell-data-br** on the Cisco Catalyst 8200 UCPE. This bridge facilitates VM data traffic through the LTE cellular interface.

```
Device# show running-config bridges bridge cell-data-br
bridges bridge cell-data-br
ip address 198.51.100.1 255.255.255.240
```

The following is a sample output from the **support show ifconfig cell-data-br** command. This command provides information about the interface identified as **cell-data-br** on the Cisco Catalyst 8200 UCPE. This interface facilitates VM data traffic through the LTE cellular interface.

```
Device# support show ifconfig cell-data-br
cell-data-br:
flags=4163<UP,BROADCAST,RUNNING,MULTICAST> mtu 1500
  inet 192.0.2.1 netmask 255.255.255.240 broadcast 192.0.2.15
  inet6 fe80::8a5:e0ff:fe18:d141 prefixlen 64 scopeid 0x20<link>
  ether 0a:a5:e0:18:d1:41 txqueuelen 1000 (Ethernet)
RX packets 0 bytes 0 (0.0 B)
RX errors 0 dropped 0 overruns 0 frame 0
TX packets 11 bytes 698 (698.0 B)
TX errors 0 dropped 0 overruns 0 carrier 0 collisions 0
```

## External Storage for Cisco ENCS 5400 and Cisco Cloud Services Platforms

**Table 11: Feature History**

Feature Name	Release Information	Description
Support for External Storage for Cisco Cloud Services Platforms	NFVIS 4.6.1	External disks are supported for Cisco Cloud Services Platforms (CSP).

### Restrictions for External Storage for Cisco ENCS 5400 and Cisco Cloud Services Platforms

- A maximum of two RAID groups can be configured for Cisco ENCS 5400 and a maximum of three RAID groups for CSP platforms.

### Information about External Storage for Cisco ENCS 5400 and Cisco Cloud Services Platforms

For details on supported storage type, number of storage devices and, RAID modes on each hardware, see the table below:

Device	Storage Details
ENCS 5400	<a href="#">Cisco 5400 Enterprise Network Compute System Hardware Installation Guide</a>



**Note** RAID controller is optional on ENCS 5400.

RAID configurations are performed from Cisco IMC for each hardware platform. For UCS-E and CSP devices, all RAID configurations should be performed before installing the NFVIS software. For ENCS 5400, because the OS installation is done on internal SSD, RAID configurations can also be done after the NFVIS software is installed.

This table provides information about the number of RAID groups supported on each platform and the NFVIS release in which the support was introduced:

Platform	Release introduced	Number of RAID groups supported
ENCS 5400	NFVIS 3.8 release	Two RAID groups: First group—extdatastore1 Other group—extdatastore2
Cisco CSP	NFVIS 4.6 release	Three RAID groups: First group—intdatastore (the OS is installed in this group) Second group—extdatastore1 Third group—extdatastore2
UCS-E Single-Wide series	NFVIS 3.5 release	One RAID group for fresh installation
UCS-E Double-Wide series	NFVIS 3.x release and previous releases	One RAID group
	NFVIS 4.1 release	Two RAID groups



**Note** Power off the system before you remove or insert disks in ENCS 5400.

To display the number of external disks on the system, use the **show system ext-disks** command.

```
nfvis# show system ext-disks
```

```
NAME
-----
extdatastore1
```

To display the disk space on an external disk, use the **show system disk-space** command.

```
nfvis# show system disk-space
```

```
ASSOCIATED
DISK NAME  PHYSICAL  TOTAL  SIZE  SIZE  USE
           DISK   SIZE  USED  AVAILABLE  PERCENT
-----
lv_data    sde2      99G   4.3G  94G     5%
lv_var     sde2      3.9G  245M  3.4G    7%
lv_root    sde2      7.8G  1.9G  5.5G   26%
extdatastore1 sda      917G  77M   871G    1%
```



**Note** For more information on the drives and how to create them, see [Managing Storage Adapters](#)

# Support for 40G Dual Port and Quad-Split NICs on Cisco Cloud Services Platforms

Table 12: Feature History

Feature Name	Release Information	Description
Support for 40G Dual Port and Quad-Split NICs in Cisco Cloud Services Platforms	NFVIS 4.7.1	Starting from this release, the 40G network interface card (NIC) supports dual port modes on Cisco Cloud Services Platform (CSP).

## Prerequisites for 40G Dual Port and Quad-Split NICs on Cisco CSP

- Remove the physical network interface card (PNIC) from all networking configurations such as DPDK and SRIOV networks.
- Remove the PNIC from all bridges.
- Remove the PNIC from the port channel.
- Remove the PNIC or virtual functions (VF) of the PNIC from any deployed VM.

## Restrictions for 40G Dual Port and Quad-Split NICs on Cisco CSP

- Plug-n-play of the 40G NIC card is not supported.
- The breakout and unbreakout commands should not be executed when a Backup and Restore function is in progress.
- The breakout and unbreakout commands should not be executed when a Factory Default function is in progress.



---

**Note** In a NFVIS Backup and Restore, the NIC card configuration mode must be the same on both the source system and the destination system. If the NIC card configuration is different, the restore command is rejected. For more information, see Appendix.

---

## Information About 40G Dual Port and Quad-Split NICs on Cisco CSP

This feature enables the 40G NIC to support two modes on Cisco CSP:

- 2x40 mode – two ports of 40G speed each.
- 4x10 mode – four ports of 10G speed each.

You can convert the 40G NIC from 2x40G mode to 4x10G mode and vice-versa using the breakout commands.

## Configure 40G Dual Port and Quad-Split NICs on Cisco CSP Using the CLI

To display the current PNIC modes and adapter information, use the following breakout commands:

```
nfvis# show pnic-breakout
```

```
nfvis# show nic
```

To change the PNIC mode from 2x40 to 4x10, use the following breakout command:

```
nfvis# hostaction pnic-breakout device 1 mode 4x10
```

To change the PNIC mode from 4x10 to 2x40, use the following un-breakout command:

```
nfvis# hostaction pnic-breakout device 1 mode 2x40
```

In case of a Return Material Authorization (RMA) of the NIC, you can forcefully breakout or un-breakout between the 2x40G mode and 4x10G mode. For more information on the RMA solution for a 40G NIC, see Appendix.

To forcefully breakout from 2x40 mode to 4x10 mode, use the following command:

```
nfvis# hostaction pnic-breakout force device 1 mode 4x10
```

To forcefully un-breakout from 4x10 mode to 2x40 mode, use the following command:

```
nfvis# hostaction pnic-breakout force device 1 mode 2x40
```

## Configuration Examples for 40G Dual Port and Quad-Split NICs on Cisco CSP

1. The following example shows how to change the PNIC mode from 2x40 to 4x10:

```
nfvis# hostaction pnic-breakout device 1 mode 4x10
Warning: Will reboot the system after the mode is changed on the 40G PNIC. All PNIC
configuration like adminstatus, duplex, lldp, promiscuous, speed, sriov, track-state
will be lost and set to default.
Are you sure you want to perform the PNIC breakout? [no,yes] yes

System message at 2021-06-02 21:15:36...
Commit performed ny via tcp using system.

Broadcast message from root@nfvis (Wed 2021-06-02 21:15:36 UTC):

The system is going down for reboot at Wed 2021-06-02 21:16:36 UTC!
```

2. The following example shows how to change the PNIC mode from 4x10 to 2x40:

```
nfvis# hostaction pnic-breakout device 1 mode 2x40
Warning: Will reboot the system after the mode is changed on the 40G PNIC. All PNIC
configuration like adminstatus, duplex, lldp, promiscuous, speed, sriov, track-state
will be lost and set to default.
Are you sure you want to perform the PNIC breakout? [no,yes] yes

System message at 2021-06-02 21:15:36...
Commit performed ny via tcp using system.

Broadcast message from root@nfvis (Wed 2021-06-02 21:15:36 UTC):

The system is going down for reboot at Wed 2021-06-02 21:16:36 UTC!
```

3. The following example shows how to forcefully breakout from the 2x40G mode to 4x10G mode:

```
nfvis# hostaction pnic-breakout force device 1 mode 4x10
Warning: Will reboot the system after the mode is changed on the 40G PNIC. All PNIC
configuration like adminstatus, duplex, lldp, promiscuous, speed, sriov, track-state
will be lost and set to default.
Are you sure you want to perform the PNIC breakout? [no,yes] yes

Broadcast message from root@nfvis (Wed 2021-06-02 21:38:53 UTC):

The system is going down for reboot at Wed 2021-06-02 21:39:53 UTC!
```

4. The following example shows how to forcefully un-breakout from the 4x10 mode to 2x40 mode:

```
nfvis# hostaction pnic-breakout force device 1 mode 2x40
Warning: Will reboot the system after the mode is changed on the 40G PNIC. All PNIC
configuration like adminstatus, duplex, lldp, promiscuous, speed, sriov, track-state
will be lost and set to default.
Are you sure you want to perform the PNIC breakout? [no,yes] yes

Broadcast message from root@nfvis (Wed 2021-06-02 22:02:40 UTC):

The system is going down for reboot at Wed 2021-06-02 22:03:40 UTC!
```

## Verify PNIC Mode Change on a 40G Dual Port and Quad-Split NICs on Cisco CSP

The following example show how to display the current PNIC modes and adapter information:

```
nfvis# show pnic-breakout
```

DEVNO	PCI	VENDOR	DEVID	ADAPTER	MODE	PNICS
1	5e	8086	1583	Cisco(R) Ethernet Converged NIC XL710-QDA2	2x40	['eth2-1', 'eth2-2']

```
nfvis# show nic
```

SLOTID	ADAPTER	VENDOR	DEVID	MODE	DEVNO	PNICS
1	Intel X520 dual port adapter	8086	10fb	NA	NA	['eth1-1', 'eth1-2']
3	Intel X710-DA4 Quad Port 10Gb SFP+ converged NIC	8086	1572	NA	NA	['eth3-1', 'eth3-2', 'eth3-3', 'eth3-4']
2	Intel XL710-QDA2 Dual Port 40Gb QSFP converged NIC	8086	1583	2x40	1	['eth2-1', 'eth2-2']
5	Intel i350 Quad Port 1Gb Adapter	8086	1521	NA	NA	['eth5-1', 'eth5-2', 'eth5-3', 'eth5-4']
4	Intel X520 dual port adapter	8086	10fb	NA	NA	['eth4-1', 'eth4-2']

```
6 Intel X520 dual port adapter 8086 10fb NA NA ['eth6-1', 'eth6-2']
```

# C8300-UCPE Virtual RAID and Supported NIMs Specifications

## C8300-UCPE Virtual RAID and Supported NIMs Specifications

The C8300-UCPE platform introduces new features that:

- support new Network Interface Modules (NIMs), specifically the C-NIM-8T and C-NIM-4X modules, starting with Cisco NFVIS Release 4.18.
- include a Virtual RAID Controller that supports Software RAID, a technology that combines multiple disk drives into a single unit for improved performance or redundancy. This allows you to create a RAID array using two identical E-SSD-U2N disks, configured as either RAID1 or RAID0.

## Prerequisites for RAID controller on C8300-UCPE

### Virtual RAID prerequisites

For the C8300-UCPE platform:

- Ensure you have two identical E-SSD-U2N disks installed.
- Enabling Virtual RAID will permanently erase all data on the E-SSD-U2N disks. Therefore, ensure these disks contain no existing data, and back up any data present before proceeding.
- The E-SSD-U2N disks must not have any virtual machines deployed on them. Undeploy any existing virtual machines before enabling Virtual RAID, as their presence will cause enablement to fail.
- If two E-SSD-U2N disks are present during NFVIS installation, RAID1 is automatically created.
- When replacing a disk, use an identical E-SSD-U2N disk.

## Restrictions for RAID and NIMs on C8300-UCPE

### Restrictions for RAID

These restrictions apply to the RAID feature on C8300-UCPE:

- Once an E-SSD-U2N disk has been enabled as part of a RAID group, it cannot be used as a standalone external disk unless virtual RAID is disabled.
- Only two identical E-SSD-U2N disks are supported in the RAID array; non-identical disks are not supported.

### Restrictions for NIMs

The NIM modules on C8300-UCPE do not support:

- L3 mode, which means they cannot perform Layer 3 routing functions.
- MACsec, a security protocol for encrypting data on Ethernet links.

## Managing Virtual RAID on C8300-UCPE

This supertask provides an overview and directs you to specific procedures for managing Virtual RAID on the C8300-UCPE. You can configure, disable, or rebuild your Virtual RAID array by following the appropriate subtask

Complete these steps to manage Virtual RAID:

### Before you begin

Ensure you have CLI access to the C8300-UCPE

### Procedure

---

- Step 1** Enable Virtual RAID. Follow the procedure in [Enable Virtual RAID on the C8300-UCPE, on page 59](#).
  - Step 2** Disable Virtual RAID. Follow the procedure in [Disable Virtual RAID on the C8300-UCPE, on page 60](#)
  - Step 3** Rebuild Virtual RAID. Follow the procedure in [Rebuild Virtual RAID on the C8300-UCPE Platform, on page 60](#).
- 

### What to do next

Verify the status of your Virtual RAID configuration using the **show system:swraid-status** command.

## Enable Virtual RAID on the C8300-UCPE

This task guides you through the CLI commands to enable and specify the RAID type for Virtual RAID on the C8300-UCPE, combining multiple disk drives into a single unit for improved performance or redundancy.

Complete these steps to enable Virtual RAID using the CLI:

### Before you begin

- Ensure you have two identical E-SSD-U2N disks installed.
- Do not store existing data on the E-SSD-U2N disks.
- Do not deploy any virtual machines on these E-SSD-U2N disks.
- If two E-SSD-U2N disks are present during NFWIS installation, RAID1 is automatically created. To manually enable RAID on the C8300-UCPE, follow the steps provided in the Procedure section.

### Procedure

---

- Step 1** Enable Virtual RAID on the C8300-UCPE.

```
nfvis# hostaction swraid-enable
```

The default RAID type is RAID1

**Step 2** Specify the RAID type (RAID0 or RAID1) for Virtual RAID.

```
nfvis# hostaction swraid-enable raid-type ?
```

Possible completions include RAID0 and RAID1.

Virtual RAID is enabled on your C8300-UCPE platform with the specified RAID type.

#### What to do next

- Verify the Virtual RAID configuration. For more information, see [Verify Virtual RAID on C8300-UCPE, on page 61](#)

## Disable Virtual RAID on the C8300-UCPE

This task provides the CLI command to disable Virtual RAID on the C8300-UCPE. This action is typically performed for maintenance or before re-purposing the drives.

Complete this step to disable Virtual RAID using the CLI:

#### Before you begin

- Ensure Virtual RAID is currently enabled on the C8300-UCPE.
- Back up any critical data from the Virtual RAID array.

#### Procedure

Disable Virtual RAID on external disks.

```
nfvis# hostaction swraid-disable
```

Virtual RAID is disabled on your C8300-UCPE.

#### What to do next

- Verify the Virtual RAID status to confirm it is disabled. For more information, see [Verify Virtual RAID on C8300-UCPE, on page 61](#)

## Rebuild Virtual RAID on the C8300-UCPE Platform

This task provides the CLI command to rebuild the Virtual RAID array on the C8300-UCPE after a disk replacement. This process restores data redundancy or integrity.

Complete this step to rebuild Virtual RAID using the CLI:

**Before you begin**

- Ensure that the disk in the Virtual RAID array has been replaced with an identical, new E-SSD-U2N disk..

**Procedure**

Rebuild Virtual RAID after replacing a faulty disk.

```
nfvis# hostaction swraid-diskreplace
```

The Virtual RAID array on your C8300-UCPE is rebuilt, restoring its intended configuration.

**What to do next**

- Verify the Virtual RAID status to confirm the rebuild process is complete and successful. For more information, see [Verify Virtual RAID on C8300-UCPE, on page 61](#)

**Verify Virtual RAID on C8300-UCPE**

By verifying the Virtual RAID status, you can confirm the operational status of your RAID array, including its health, level, and disk synchronization.

This section provides the steps to check the Virtual RAID status on the C8300-UCPE.

**Before you begin**

- Ensure you have CLI access to the C8300-UCPE.

**Procedure**

From the CLI interface of the C8300-UCPE, execute the following command:

```
nfvis# show system:swraid-status
```

```
swraid-status raid-state Healthy
swraid-status raid-name /dev/md127
swraid-status raid-level 1
swraid-status sync-status True
swraid-status working-devices 2
swraid-status active-devices 2
swraid-status failed-devices 0
swraid-status disk-size 1.8T
swraid-status used-space 32K
DISK NAME          SLOT          STATE
/dev/nvme1n1p1     U2-Upper-Slot active sync
/dev/nvme2n1p1     U2-Lower-Slot active sync
```

**What to do next**

Analyze the output to confirm the Virtual RAID's configuration (level, name, device count), overall health (state, sync status), and the status of individual disks (active, failed).