



## Chassis Overview

---

This chapter provides an overview of the Cisco NCS 4009 chassis and components.

- [About the Cisco NCS 4009 Chassis, on page 1](#)
- [Chassis Components, on page 4](#)
- [Chassis Cable Management, on page 8](#)
- [Safety Guidelines, on page 8](#)

## About the Cisco NCS 4009 Chassis

The following cards are supported in the Cisco NCS 4009 chassis:

- 2 slots for route processor cards (RPs)
- 9 slots for line cards (LCs)
- 4 slots for fabric cards (FCs)

The Cisco NCS 4009 chassis is rack mountable. It is compatible with the following standard rail spacing:

- ANSI 19-inch or 23-inch
- ETSI



---

**Note** For the ANSI 19-inch rack, the minimum front opening must be 17.72 inches (450 mm) to allow for chassis insertion. The installation kit includes different brackets for each type of rack.

---

The Cisco NCS 4009 chassis contains its own power and cooling systems. Power systems are available using AC or DC power. A fan tray is located in the top slot of the chassis.



---

**Note** The installation of a Cisco NCS 4009 chassis may require space, power, and cooling modifications to a facility. Therefore, you should plan the site well in advance of the scheduled delivery of the chassis system.

---

Figure 1: Front View of the Cisco NCS 4009 Chassis

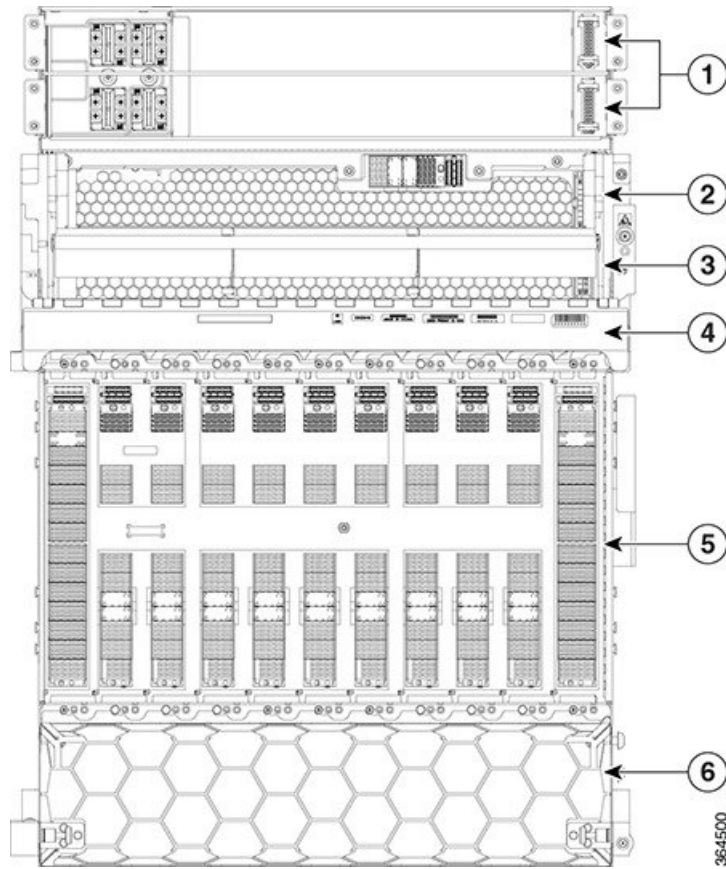

1	Power trays (2)	4	Fiber management
2	External Connection Unit (ECU)/Craft Panel/Air Outlet	5	Card cage containing: <ul style="list-style-type: none"> <li>• 9 line card slots</li> <li>• 2 route processor slots</li> </ul>
3	Fan tray	6	4 fabric card slots covered by the inlet air filter

**Figure 2: Partial Chassis View with Craft Panel**

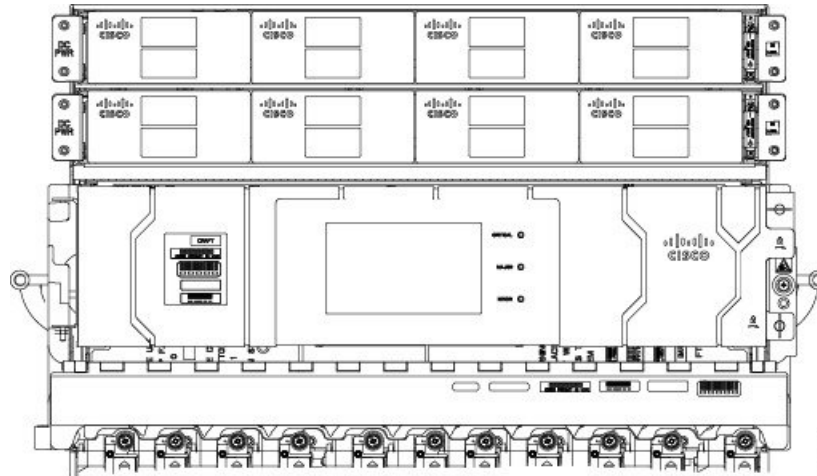

**Note** There is an air outlet on the top of chassis below the bottom power tray.

**Figure 3: Rear View of the Cisco NCS 4009 AC Chassis**

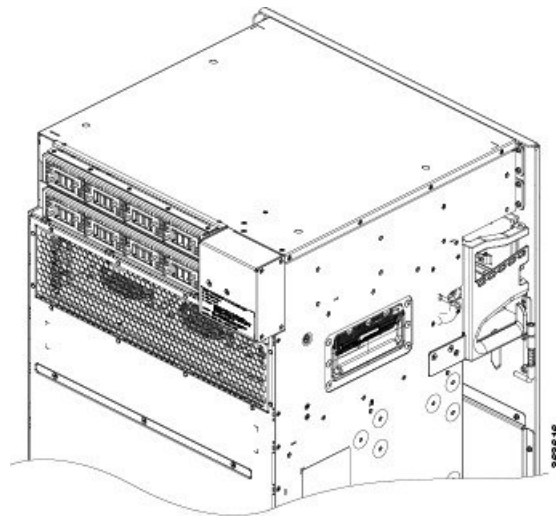

*Figure 4: Rear View of the Cisco NCS 4009 DC Chassis*

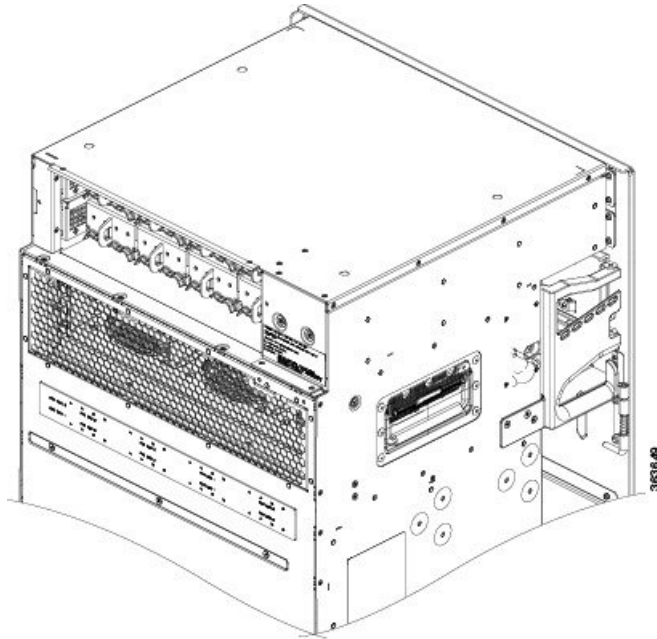

*Figure 5: Rear View of the Cisco NCS 4009 DC Chassis with DC Power Front Connection Adapter*

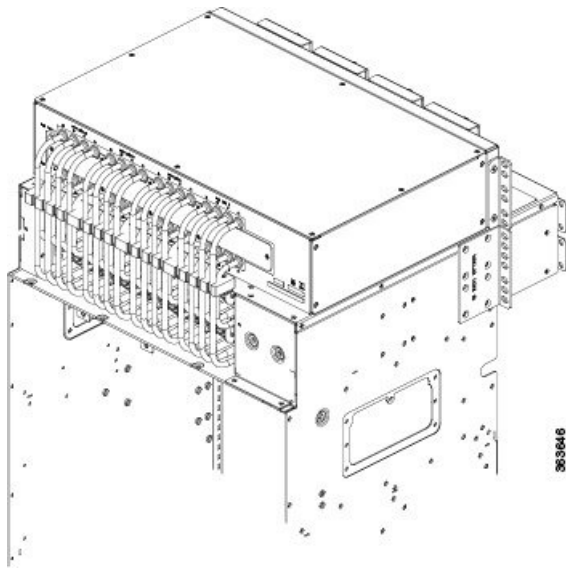

## Chassis Components

This table lists the main components of the Cisco NCS 4009 chassis.

Table 1: Main Components of the Cisco NCS 4009 Chassis

Component	Description
route processor cards (RPs)	Two RP cards (RP0/RP1) are inserted into the front of the chassis. These cards provide the intelligence of the system by functioning as the system controller and providing route processing and chassis management. The RP cards also monitor system alarms and control the system fans. The LEDs on the front panel indicate active alarm conditions.
fabric cards (FCs)	Four FCs are inserted into the bottom of the chassis. The FCs provide the switch fabric for the routing system and performs the cross-connect function of the routing system, connecting every LC to each other. The switch fabric receives ingress user data from one LC slot and performs the switching necessary to route the data to the appropriate egress LC slot.
line cards (LCs)	As many as nine LCs can be inserted into the front of the chassis. These cards provide the physical interfaces and optical connections for the user data.
external connection unit (ECU)	The ECU provides all shelf electrical I/O connectivity to the active and standby route-processor line cards. The ECU is located behind the craft panel.
craft panel	The craft panel can install, configure, monitor, and troubleshoot the Cisco NCS 4009 chassis applications at the node and at the network level. The craft panel is located on top of the ECU.
fan tray	One fan tray is inserted into the front of the chassis behind the craft panel. The fan tray cools the card rack. The fan tray contains six axial fans. The fans pull cooling air through the chassis from front to rear.
air filter	One air filter is located above the slots of the fabric cards.
power trays	Two power trays provide redundant power to the chassis. Both AC and DC power trays are available. Each power tray holds up to four AC or DC power modules. A power tray is a field serviceable unit (FSU). A mixture of AC and DC power is not supported in the chassis.  <b>Note</b> You must power off the chassis before replacing a power tray.
fiber management tray	A fiber management tray is located on the top of the chassis.

## Chassis Slot Numbers

This section identifies the location and slot numbers for the cards and power modules that plug into the chassis.

Figure 6: Cisco NCS 4009 Chassis Slot Numbers

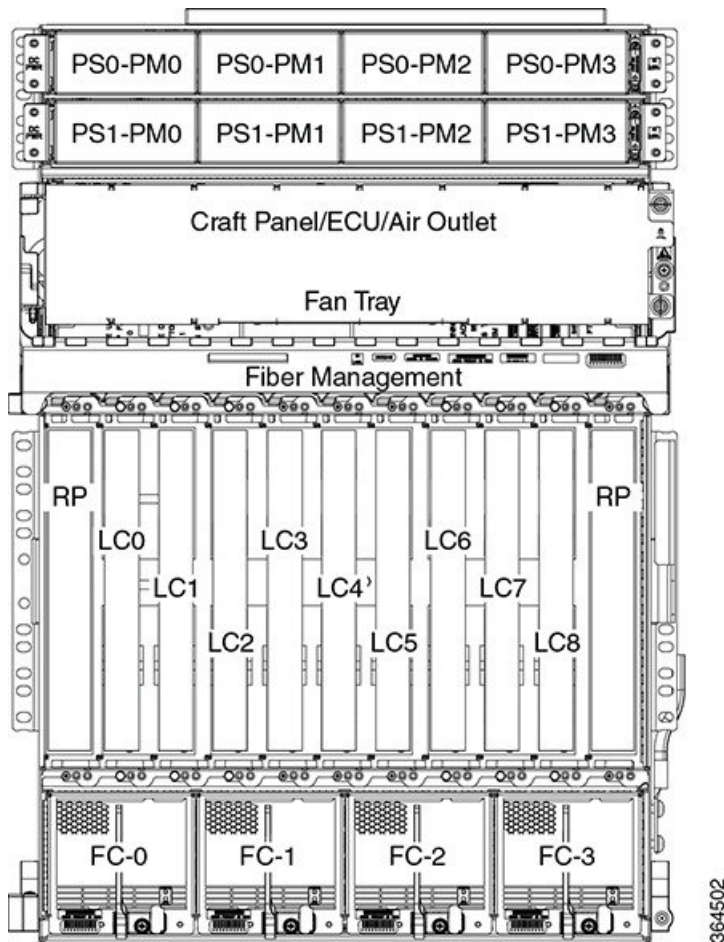

The chassis has the following card slots:

- Nine LC slots (LC0 to LC8)
- Two RP slots (RP0 and RP1)
- Four FC slots (FC0 to FC3)
- One fan tray
- One external connection unit (ECU) located above the fan tray behind the craft panel
- One fiber management tray at the top of the chassis
- One air inlet and one air outlet
- Eight power modules for redundancy
- The upper four AC or DC power trays (0-3) are contained within power shelf 0 (PS0) and the lower four AC or DC power trays (4-7) are contained within power shelf 1 (PS1).

The cards have electrical plugs at the back that plug into electrical connectors on the shelf backplane. When the ejectors are fully closed, the card plugs into the assembly backplane.

The chassis has eight power modules for redundancy:

- The upper four power modules are contained within power tray 0 (PS0). They are named as follows: PS0-PM0, PS0-PM1, PS0-PM2, and PS0-PM3.

- The lower four power modules are contained within power tray 1 (PS1). They are named as follows: PS1-PM0, PS1-PM1, PS1-PM2, and PS1-PM3.

## Card Slot Requirements

This figure shows card installation for the Cisco NCS 4009 chassis.

*Figure 7: Installing Cards in the Cisco NCS 4009 Chassis*

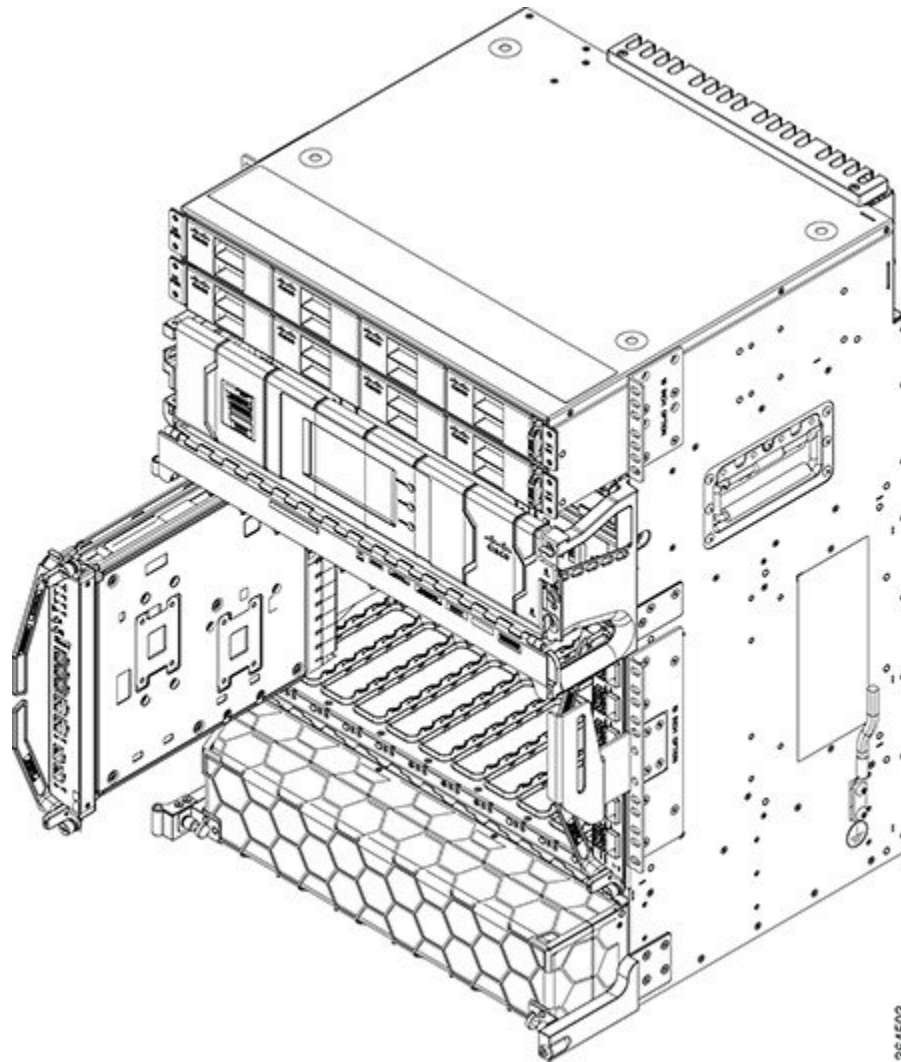

Slots FC0 through FC3 are dedicated to fabric cards. Slots RP0 and RP1 are reserved for route processor cards. Slots LC0 to LC8 are reserved for line cards.

Shelf assembly slots have symbols indicating the type of cards that you can install in them. Each Cisco NCS 4009 card has a corresponding symbol. The symbol on the card must match the symbol on the slot.

Table 2: Slot and Card Symbols

Symbol Color/Shape	Definition
Orange/Circle	Slots LC0 through LC8. Only install line cards with a circle symbol on the faceplate.
Pink/Triangle	Slots LC0 through LC8. Only install line cards with circle or a triangle symbol on the faceplate.
Blue/Hexagon	Slots LC0 through LC8. Only install line cards with a blue hexagon symbol on the faceplate.
Purple/Square	Slots RP0 and RP1. Only install route processor cards with a square symbol on the faceplate.
Lilac/Cross	Slots FC0 through FC3. Only install fabric cards with a cross symbol on the faceplate.

## Chassis Cable Management

The Cisco NCS 4009 chassis has cable management features for the front side only. The horizontal cable management bracket is located above the card cage.

## Safety Guidelines

Before you perform any Cisco NCS 4009 chassis installation procedures, review the safety guidelines in this section to avoid injuring yourself or damaging the equipment.



**Note** Review the safety warnings listed in Regulatory Compliance and Safety Information for the Cisco Network Convergence System 4000 Series before installing, configuring, or troubleshooting any installed card.



**Note** Power off the system before removing or installing a power tray.

The following guidelines are for your safety and to protect equipment. The guidelines do not include all hazards. Be alert.

- Never attempt to lift an object that might be too heavy for you to lift by yourself.
- Keep the work area clear and dust-free during and after installation. Do not allow dirt or debris to enter into any laser-based components.
- Keep tools and chassis components away from walk areas.
- Do not wear loose clothing, jewelry, and other items that could get caught in the chassis while working with the chassis and its components.
- Use Cisco equipment in accordance with its specifications and product-usage instructions.



- Do not work alone if potentially hazardous conditions exist.
- Make sure that your installation follows national and local electrical codes: in the United States, National Fire Protection Association (NFPA) 70, United States National Electrical Code; in Canada, Canadian Electrical Code, part I, CSA C22.1; in other countries, International Electrotechnical Commission (IEC) 60364, part 1 through part 7.
- Connect only a DC power source that follows the safety extra-low voltage (SELV) requirements in UL/CSA/IEC/EN 60950-1 and AS/NZS 60590 to the DC input power system.
- Make sure that you have a readily accessible two-poled disconnect device incorporated in the fixed configuration wiring of a DC input power system.
- Make sure that you provide short-circuit (overcurrent) protection as part of the building installation.

### Safety Labels

Cisco NCS 4000 Series chassis is classified as Hazard Level 1M as per IEC 60825-1, since it includes optical pluggable devices Laser Class 1 or 1M.

The Class 1M Laser Product label is shown in the following figure.

**Figure 8: Class 1M Laser Product Label**



This section explains the significance of the safety labels attached to the NCS 4009 chassis. You must understand all warning labels before working on the chassis.

**Figure 9: Class 1M Laser Product Label**



### Safety Precaution for Module Installation and Removal

Ensure to observe the following safety precautions when you are working with the chassis modules.

**Invisible laser radiations present.**Statement 1016

**Invisible laser radiation may be emitted from disconnected fibers or connectors. Do not stare into beams or view directly with optical instruments.**Statement 1051

*Figure 10: Class 1M Laser Product Label*



## Preventing Electrostatic Discharge

Electrostatic discharge (ESD) damage, which can occur when electronic cards or components are improperly handled, results in complete or intermittent failures. We recommend use of an ESD-preventive wrist strap whenever you handle network equipment or one of its components.

Following are guidelines for preventing ESD damage:

- Always use an ESD-preventive wrist or ankle strap, and ensure that it makes good skin contact. Connect the equipment end of the connection cord to an ESD jack or a bare metal surface on the chassis (ensure the chassis is grounded).
- Handle a card by its ejector levers, when applicable, or its metal carrier only; avoid touching the board or connector pins.
- Place a removed card board side up on an antistatic surface or in a static-shielding bag. If you plan to return the component to the factory, immediately place it in a static-shielding bag.
- Avoid contact between a card and clothing. The wrist strap protects the board from only ESD voltage on the body; ESD voltage on clothing can still cause damage.

Figure 11: ESD Jacks—Top of Chassis

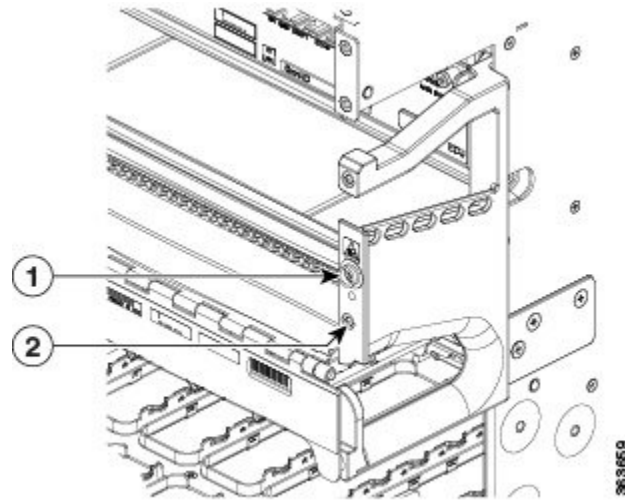

1	Top ETSI connection point	2	Top ANSI jacket point
---	---------------------------	---	-----------------------

Figure 12: ESD Jacks—Bottom of Chassis

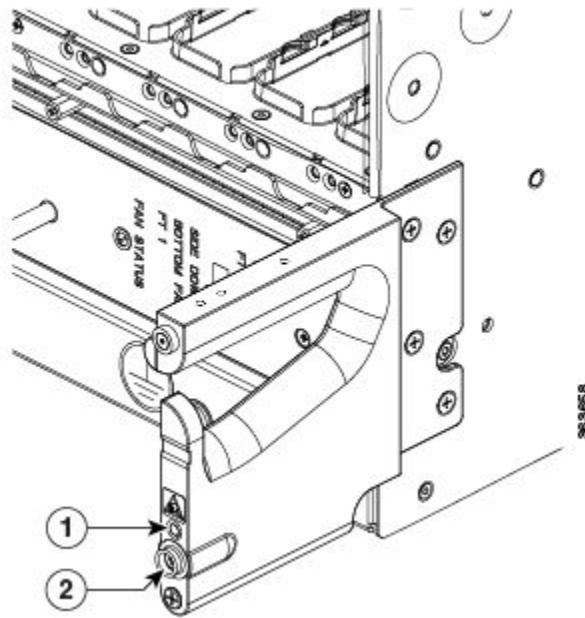

1	Bottom ANSI jacket point	2	Bottom ETSI connection point
---	--------------------------	---	------------------------------

