



LISP Multicast

The LISP Multicast feature introduces support for carrying multicast traffic over a Locator ID Separation Protocol (LISP) overlay. This support currently allows for unicast transport of multicast traffic with head-end replication at the root ingress tunnel router (ITR) site. This allows network operators to use LISP to carry multicast traffic over core networks that do not have native multicast capabilities.

- [Finding Feature Information, on page 1](#)
- [Prerequisites for LISP Multicast, on page 1](#)
- [Restrictions for LISP Multicast, on page 2](#)
- [Information About LISP Multicast, on page 2](#)
- [How to Configure LISP Multicast, on page 3](#)
- [Verifying LISP Multicast, on page 7](#)
- [Configuration Examples for LISP Multicast, on page 9](#)
- [Additional References for LISP Multicast, on page 16](#)
- [Feature Information for LISP Multicast, on page 17](#)

Finding Feature Information

Your software release may not support all the features documented in this module. For the latest caveats and feature information, see [Bug Search Tool](#) and the release notes for your platform and software release. To find information about the features documented in this module, and to see a list of the releases in which each feature is supported, see the feature information table.

Use Cisco Feature Navigator to find information about platform support and Cisco software image support. To access Cisco Feature Navigator, go to www.cisco.com/go/cfn. An account on Cisco.com is not required.

Prerequisites for LISP Multicast

- You must configure basic LISP services on the device. Basic LISP configurations are covered in "Configuring Basic LISP" section of this configuration guide.
- You must configure IPv6 multicast and LISP services on the device. The configuration of IPv6 multicast over LISP is covered in "How to Configure LISP Multicast" and "Example: Configuring IPv6 Multicast over LISP" sections of this guide.

Restrictions for LISP Multicast

- LISP multicast does not support IPv6 endpoint identifiers (EIDs) or IPv6 routing locators (RLOCs). Only IPv4 EIDs and IPv4 RLOCs are supported.
- LISP multicast does not support Dense Mode or Bidirectional Protocol Independent Multicast (PIM). Only PIM-Sparse Mode (SM) and PIM Source Specific Multicast (SSM) modes are supported.
- LISP multicast does not support group to Rendezvous Point (RP) mapping distribution mechanisms, Auto-RP and Bootstrap Router (BSR). Only static-RP configuration is supported.
- LISP multicast does not support LISP Virtual Machine Mobility (VM-Mobility) deployment. That is, LISP multicast cannot be used as a data center interconnect (DCI) mechanism.
- IPv6 LISP multicast does not support IPv6 routing locators. Additionally, it does not support multicast transport.



Note IPv6 LISP multicast is supported only from Cisco IOS Release 16.2 onwards, though releases earlier than 16.2 supports only IPv4 LISP multicast

Information About LISP Multicast

The implementation of LISP multicast includes the following features:

- Mapping of multicast source addresses as LISP endpoint identifiers (EIDs). (Destination group addresses are not topology dependent).
- Building the multicast distribution tree across LISP overlays.
- Unicast head-end replication of multicast data packets from sources within a root ingress tunnel router (ITR) site to receiver egress tunnel routers (ETRs).
- Support for ASM (Any Source Multicast) and SSM (Source Specific Multicast).
- Support for various combinations of LISP and non-LISP capable source and receiver sites.
- Support for IPv6 endpoint identifiers (EIDs).



Note If a LISP xTR is also a PIM First Hop Router (FH) or a Rendezvous Point (RP) and the device is only receiving traffic, ensure that at least one interface on the device is covered by a local LISP database mapping. No additional configuration is required to ensure that proper address is selected.

How to Configure LISP Multicast

Configuring LISP Multicast

Perform this task to enable the LISP multicast functionality on the xTR.

Before you begin

Ensure that generic multicast functionality has been enabled on the required devices of the LISP site and PIM sparse mode has been enabled on the required interfaces of these devices.

SUMMARY STEPS

1. **enable**
2. **configure terminal**
3. **ip multicast-routing** [**distributed**]
4. Enter one of the following:
 - **ip pim rp-address** *rp-address*
 - **ip pim ssm** {**default** | **range** {*access-list-number* | *access-list-name*}}
5. **interface lisp** *interface-number*
6. **ipv6 pim lisp transport** [**ipv4**]
7. **ip pim sparse-mode**
8. **exit**
9. **interface** *interface-type* *interface-number*
10. **description** *string*
11. **ip pim sparse-mode**
12. **end**

DETAILED STEPS

Procedure

	Command or Action	Purpose
Step 1	enable Example: Device> enable	Enables privileged EXEC mode.
Step 2	configure terminal Example: Device# configure terminal	Enters global configuration mode.

	Command or Action	Purpose
Step 3	ip multicast-routing [distributed] Example: Device(config)# ip multicast-routing	Enables IP multicast routing.
Step 4	Enter one of the following: • ip pim rp-address <i>rp-address</i> • ip pim ssm { default range { <i>access-list-number</i> <i>access-list-name</i> }} Example: Device(config)# ip pim rp-address 10.1.0.2 Example: Device(config)# ip pim ssm default	<ul style="list-style-type: none"> Statically configures the address of a Protocol Independent Multicast (PIM) rendezvous point (RP) for multicast groups. Defines the Source Specific Multicast (SSM) range of IP multicast addresses.
Step 5	interface lisp <i>interface-number</i> Example: Device(config)# interface LISP0	Selects a LISP interface to configure and enters interface configuration mode.
Step 6	ipv6 pim lisp transport [ipv4] Example: Device(config-if)# ipv6 pim lisp transport unicast ipv4	Selects a LISP interface to configure and enters interface configuration mode.
Step 7	ip pim sparse-mode Example: Device(config-if)# ip pim sparse-mode	Enables Protocol Independent Multicast (PIM) on an interface for sparse-mode operation.
Step 8	exit Example: Device(config-if)# exit	Exits interface configuration mode and enters global configuration mode.
Step 9	interface <i>interface-type interface-number</i> Example: Device(config)# interface GigabitEthernet0/0/0	Configures the LISP interface facing the site and enters interface configuration mode.
Step 10	description <i>string</i> Example: Device(config-if)# description Link To Site	Configures a description text for the interface.

	Command or Action	Purpose
Step 11	ip pim sparse-mode Example: Device(config-if)# ip pim sparse-mode	Enables Protocol Independent Multicast (PIM) on an interface for sparse-mode operation.
Step 12	end Example: Device(config-if)# end	Ends the current configuration session and returns to privileged EXEC mode.

Configuring LISP Multicast in VRFs

Perform this task to enable the LISP multicast functionality on an xTR with Virtual Routing and Forwarding (VRF) mode configured.

Before you begin

Ensure that generic multicast functionality has been enabled on the required devices of the LISP site and that PIM sparse mode has been enabled on the required interfaces of these devices.

SUMMARY STEPS

1. **enable**
2. **configure terminal**
3. **vrf definition** *vrf-name*
4. **address-family ipv4**
5. **exit**
6. **exit**
7. **ip multicast-routing vrf** *vrf-name* [**distributed**]
8. Enter one of the following:
 - **ip pim vrf** *vrf-name* **rp-address** *ip-address*
 - **ip pim vrf** *vrf-name* **ssm** {**default** | **range** {*access-list-number* | *access-list-name*}}
9. **interface lisp** *interface-number*
10. **ip pim sparse-mode**
11. **exit**
12. **interface** *interface-type* *interface-number*
13. **vrf forwarding** *vrf-name*
14. **description** *string*
15. **ip pim** *sparse-mode*
16. **end**

DETAILED STEPS

Procedure

	Command or Action	Purpose
Step 1	enable Example: Device> enable	Enables privileged EXEC mode.
Step 2	configure terminal Example: Device# configure terminal	Enters global configuration mode.
Step 3	vrf definition <i>vrf-name</i> Example: Device(config)# vrf definition VRF1	Configures a virtual routing and forwarding (VRF) routing table instance and enters VRF configuration mode.
Step 4	address-family ipv4 Example: Device(config-vrf)# address-family ipv4	Configures an address family for the VRF and enters VRF address family configuration mode.
Step 5	exit Example: Device(config-vrf-af)# exit	Exits VRF address family configuration mode and enters VRF configuration mode.
Step 6	exit Example: Device(config-vrf)# exit	Exits VRF configuration mode and enters global configuration mode.
Step 7	ip multicast-routing vrf <i>vrf-name</i> [distributed] Example: Device(config)# ip multicast-routing vrf VRF1 distributed	Enables IP multicast routing.
Step 8	Enter one of the following: <ul style="list-style-type: none"> • ip pim vrf <i>vrf-name</i> rp-address <i>ip-address</i> • ip pim vrf <i>vrf-name</i> ssm {default range {<i>access-list-number</i> <i>access-list-name</i>}} Example: Device(config)# ip pim vrf VRF1 rp-address 10.1.0.2 Example: Device(config)# ip pim vrf VRF1 ssm default	<ul style="list-style-type: none"> • Statically configures the address of a Protocol Independent Multicast (PIM) rendezvous point (RP) for multicast groups. • Defines the Source Specific Multicast (SSM) range of IP multicast addresses.

	Command or Action	Purpose
Step 9	interface lisp <i>interface-number</i> Example: Device(config)# interface lisp 22.10	Selects a LISP interface to configure and enters interface configuration mode.
Step 10	ip pim sparse-mode Example: Device(config-if)# ip pim sparse-mode	Enables Protocol Independent Multicast (PIM) on an interface for sparse-mode operation.
Step 11	exit Example: Device(config-if)# exit	Exits interface configuration mode and enters global configuration mode.
Step 12	interface <i>interface-type interface-number</i> Example: Device(config)# interface GigabitEthernet0/0/0	Configures the LISP interface facing the site and enters interface configuration mode.
Step 13	vrf forwarding <i>vrf-name</i> Example: Device(config-if)# vrf forwarding VRF1	Enables VRF forwarding on the interface.
Step 14	description <i>string</i> Example: Device(config-if)# description Link To Site	Configures a description text for the interface.
Step 15	ip pim sparse-mode Example: Device(config-if)# ip pim sparse-mode.	Enables Protocol Independent Multicast (PIM) on an interface for sparse-mode operation.
Step 16	end Example: Device(config-if)# end	Ends the current configuration session and returns to privileged EXEC mode.

Verifying LISP Multicast

Perform this task to verify the configuration of LISP multicast routes on a device.

SUMMARY STEPS

1. **show ip mroute** *multicast-ip-address*
2. **ping** *multicast-ip-address*

DETAILED STEPS

Procedure

Step 1 **show ip mroute** *multicast-ip-address*

Example:

The following example shows how the IP multicast routing table is displayed using the **show ip mroute** command:

```
Device# show ip mroute 239.4.4.4

IP Multicast Routing Table
Flags: D - Dense, S - Sparse, B - Bidir Group, s - SSM Group, C - Connected,
       L - Local, P - Pruned, R - RP-bit set, F - Register flag,
       T - SPT-bit set, J - Join SPT, M - MSDP created entry, E - Extranet,
       X - Proxy Join Timer Running, A - Candidate for MSDP Advertisement,
       U - URD, I - Received Source Specific Host Report,
       Z - Multicast Tunnel, z - MDT-data group sender,
       Y - Joined MDT-data group, y - Sending to MDT-data group,
       G - Received BGP C-Mroute, g - Sent BGP C-Mroute,
       N - Received BGP Shared-Tree Prune, n - BGP C-Mroute suppressed,
       Q - Received BGP S-A Route, q - Sent BGP S-A Route,
       V - RD & Vector, v - Vector, p - PIM Joins on route,
       x - VxLAN group
Outgoing interface flags: H - Hardware switched, A - Assert winner, p - PIM Join
Timers: Uptime/Expires
Interface state: Interface, Next-Hop or VCD, State/Mode

(*, 239.4.4.4), 00:06:25/00:02:39, RP 10.1.0.2, flags: SJCL
  Incoming interface: Serial0/0, RPF nbr 10.1.0.2
  Outgoing interface list:
    Loopback2, Forward/Sparse, 00:06:24/00:02:39

(*, 224.0.1.40), 00:06:25/00:02:37, RP 10.1.0.2, flags: SJCL
  Incoming interface: Serial0/0, RPF nbr 10.1.0.2
  Outgoing interface list:
    Loopback2, Forward/Sparse, 00:06:24/00:02:37
```

Step 2 **ping** *multicast-ip-address*

Example:

The following example shows how to verify basic multicast network connectivity by pinging the multicast address:

```
Device# ping 239.4.4.4

Type escape sequence to abort.
Sending 1, 100-byte ICMP Echos to 239.4.4.4, timeout is 2 seconds:

Reply to request 0 from 192.168.0.1, 15 ms
Reply to request 0 from 10.1.0.2, 58 ms
Reply to request 0 from 10.1.0.2, 58 ms
```

```

Reply to request 0 from 10.1.0.1, 35 ms
Reply to request 0 from 10.1.0.2, 34 ms
Reply to request 0 from 10.1.0.1, 15 ms

```

Configuration Examples for LISP Multicast

Example: Configuring LISP Multicast

The following example shows how to configure LISP Multicast in the topology given below:

Figure 1: LISP Multicast Topology

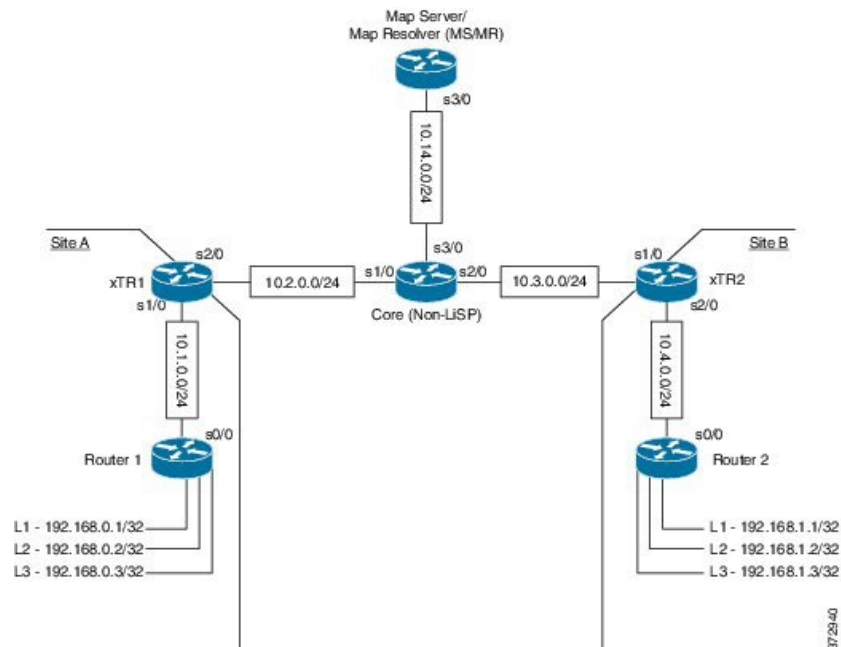

Router 1

The following example shows how to configure LISP multicast in Router 1:

```

Device# show startup-config

!
ip multicast-routing
!
interface Loopback1
 ip address 192.168.0.1 255.255.255.255
 ip pim sparse-mode
 ip igmp join-group 239.4.4.4

```

```

serial restart-delay 0
!
interface Loopback2
ip address 192.168.0.2 255.255.255.255
ip pim sparse-mode
ip igmp join-group 239.4.4.4
serial restart-delay 0
!
interface Loopback3
ip address 192.168.0.3 255.255.255.255
ip pim sparse-mode
ip igmp join-group 239.4.4.4
serial restart-delay 0
!
interface Serial0/0
ip address 10.1.0.1 255.255.255.0
ip pim sparse-mode
serial restart-delay 0
!
router rip
version 2
network 10.0.0.0
network 192.168.0.0
default-information originate
!
ip forward-protocol nd
!
ip pim rp-address 10.1.0.2
!
!
End

```

The following example shows how to verify the configuration of LISP multicast routes in Router 1:

```
Device# show ip mroute
```

```

IP Multicast Routing Table
Flags: D - Dense, S - Sparse, B - Bidir Group, s - SSM Group, C - Connected,
       L - Local, P - Pruned, R - RP-bit set, F - Register flag,
       T - SPT-bit set, J - Join SPT, M - MSDP created entry, E - Extranet,
       X - Proxy Join Timer Running, A - Candidate for MSDP Advertisement,
       U - URD, I - Received Source Specific Host Report,
       Z - Multicast Tunnel, z - MDT-data group sender,
       Y - Joined MDT-data group, y - Sending to MDT-data group,
       G - Received BGP C-Mroute, g - Sent BGP C-Mroute,
       N - Received BGP Shared-Tree Prune, n - BGP C-Mroute suppressed,
       Q - Received BGP S-A Route, q - Sent BGP S-A Route,
       V - RD & Vector, v - Vector, p - PIM Joins on route,
       x - VxLAN group
Outgoing interface flags: H - Hardware switched, A - Assert winner, p - PIM Join
Timers: Uptime/Expires
Interface state: Interface, Next-Hop or VCD, State/Mode

(*, 239.4.4.4), 00:00:49/00:02:16, RP 10.1.0.2, flags: SJCL
  Incoming interface: Serial0/0, RPF nbr 10.1.0.2
  Outgoing interface list:
    Loopback2, Forward/Sparse, 00:00:48/00:02:12

(*, 224.0.1.40), 00:00:49/00:02:11, RP 10.1.0.2, flags: SJCL
  Incoming interface: Serial0/0, RPF nbr 10.1.0.2
  Outgoing interface list:

```

```
Loopback2, Forward/Sparse, 00:00:48/00:02:11
```

The following example shows how to verify basic multicast network connectivity from Router 1 by pinging the multicast address:

```
Device# ping 239.4.4.4
```

```
Type escape sequence to abort.
```

```
Sending 1, 100-byte ICMP Echos to 239.4.4.4, timeout is 2 seconds:
```

```
Reply to request 0 from 192.168.0.1, 9 ms
Reply to request 0 from 10.1.0.2, 48 ms
Reply to request 0 from 192.168.0.2, 16 ms
Reply to request 0 from 192.168.0.3, 16 ms
Reply to request 0 from 10.1.0.1, 38 ms
Reply to request 0 from 10.1.0.2, 38 ms
Reply to request 0 from 10.1.0.2, 29 ms
Reply to request 0 from 10.1.0.1, 9 ms
```

xTR1

The following example shows how to configure LISP multicast in xTR1:

```
Device# show startup-config
```

```
!
ip multicast-routing
!
interface LISP0
 ip pim sparse-mode
!
interface Serial1/0
 ip address 10.1.0.2 255.255.255.0
 ip pim sparse-mode
 serial restart-delay 0
!
interface Serial2/0
 ip address 10.2.0.1 255.255.255.0
 serial restart-delay 0
!
router lisp
 database-mapping 192.168.0.0/24 10.2.0.1 priority 1 weight 100
 ipv4 itr map-resolver 10.14.0.14
 ipv4 itr
 ipv4 etr map-server 10.14.0.14 key password123
 ipv4 etr
 exit
!
!
router rip
 version 2
 network 10.0.0.0
 default-information originate
!
ip pim rp-address 10.1.0.2
ip route 0.0.0.0 0.0.0.0 10.2.0.2
```

```
!
```

Router 2

The following example shows how to configure LISP multicast in Router 2:

```
Device# show startup-config
```

```
!
ip multicast-routing
!
interface Loopback1
 ip address 192.168.1.1 255.255.255.255
 ip pim sparse-mode
 ip igmp join-group 239.4.4.4
 serial restart-delay 0
!
interface Loopback2
 ip address 192.168.1.2 255.255.255.255
 ip pim sparse-mode
 ip igmp join-group 239.4.4.4
 serial restart-delay 0
!
interface Loopback3
 ip address 192.168.1.3 255.255.255.255
 ip pim sparse-mode
 ip igmp join-group 239.4.4.4
 serial restart-delay 0
!
interface Serial0/0
 ip address 10.4.0.2 255.255.255.0
 ip pim sparse-mode
 serial restart-delay 0
!
!
router rip
 version 2
 network 10.0.0.0
 network 192.168.1.0
 default-information originate
!
ip forward-protocol nd
!
!
ip pim rp-address 10.1.0.2
!
!
End
```

The following example shows how to verify the configuration of LISP multicast routes in Router 2:

```
Device# show ip mroute
```

```
IP Multicast Routing Table
Flags: D - Dense, S - Sparse, B - Bidir Group, s - SSM Group, C - Connected,
       L - Local, P - Pruned, R - RP-bit set, F - Register flag,
```

```

T - SPT-bit set, J - Join SPT, M - MSDP created entry, E - Extranet,
X - Proxy Join Timer Running, A - Candidate for MSDP Advertisement,
U - URD, I - Received Source Specific Host Report,
Z - Multicast Tunnel, z - MDT-data group sender,
Y - Joined MDT-data group, y - Sending to MDT-data group,
G - Received BGP C-Mroute, g - Sent BGP C-Mroute,
N - Received BGP Shared-Tree Prune, n - BGP C-Mroute suppressed,
Q - Received BGP S-A Route, q - Sent BGP S-A Route,
V - RD & Vector, v - Vector, p - PIM Joins on route,
x - VxLAN group
Outgoing interface flags: H - Hardware switched, A - Assert winner, p - PIM Join
Timers: Uptime/Expires
Interface state: Interface, Next-Hop or VCD, State/Mode

(*, 239.4.4.4), 00:12:59/00:02:01, RP 10.4.0.1, flags: SJCL
  Incoming interface: Serial0/0, RPF nbr 10.4.0.1
  Outgoing interface list:
    Loopback2, Forward/Sparse, 00:12:58/00:02:01

(*, 224.0.1.40), 00:12:59/00:02:03, RP 10.4.0.1, flags: SJCL
  Incoming interface: Serial0/0, RPF nbr 10.4.0.1
  Outgoing interface list:
    Loopback2, Forward/Sparse, 00:12:58/00:02:03

```

The following example shows how to verify basic multicast network connectivity from Router 2 by pinging the multicast address:

```

Device# ping 239.4.4.4

Type escape sequence to abort.
Sending 1, 100-byte ICMP Echos to 239.4.4.4, timeout is 2 seconds:

Reply to request 0 from 192.168.1.1, 2 ms
Reply to request 0 from 10.3.0.2, 26 ms
Reply to request 0 from 10.4.0.1, 26 ms
Reply to request 0 from 192.168.1.2, 2 ms
Reply to request 0 from 192.168.1.3, 8 ms
Reply to request 0 from 10.4.0.1, 16 ms
Reply to request 0 from 10.4.0.1, 16 ms
Reply to request 0 from 10.4.0.2, 2 ms

```

xTR2

The following example shows how to configure LISP multicast in xTR2:

```

Device# show startup-config

!
ip multicast-routing
!
interface LISPO
 ip pim sparse-mode
!
!
interface Serial1/0
 ip address 10.3.0.2 255.255.255.0

```

```

    serial restart-delay 0
  !
interface Serial2/0
  ip address 10.4.0.1 255.255.255.0
  ip pim sparse-mode
  serial restart-delay 0
  !
!
router lisp
  database-mapping 192.168.1.0/24 10.3.0.2 priority 1 weight 100
  ipv4 itr map-resolver 10.14.0.14
  ipv4 itr
  ipv4 etr map-server 10.14.0.14 key Amel
  ipv4 etr
  exit
!
router rip
  version 2
  network 10.0.0.0
  default-information originate
  !
  ip pim rp-address 10.1.0.2
  ip route 0.0.0.0 0.0.0.0 10.3.0.1
  !

```

MS/MR

The following example shows how to configure LISP multicast in MS/MR:

Device# **show startup-config**

```

!
ip multicast-routing
!
interface Serial3/0
  ip address 10.14.0.14 255.255.255.0
  serial restart-delay 0
  !
!
router lisp
  site Site-A
    authentication-key password123
    eid-prefix 192.168.0.0/24
    exit
  !
  site Site-B
    authentication-key Amel
    eid-prefix 192.168.1.0/24
    exit
  !
  ipv4 map-server
  ipv4 map-resolver
  exit
!
ip route 0.0.0.0 0.0.0.0 10.14.0.1
!

```

Core

The following example shows how to configure LISP multicast in the Core router:

```
Device# show startup-config

!
ip multicast-routing
!
interface Ethernet0/0
 ip address 10.14.0.1 255.255.255.0
 serial restart-delay 0
!
interface Serial1/0
 ip address 10.2.0.2 255.255.255.0
 serial restart-delay 0
!
interface Serial2/0
 ip address 10.3.0.1 255.255.255.0
 serial restart-delay 0
!
```

Example: Configuring LISP Multicast in VRFs

The following example shows how to enable and configure a simple LISP site with one IPv4 Routing locator (RLOC) and one IPv4 Endpoint identifier (EID) using xTR, a device which functions both as an Ingress tunnel router (ITR) and an Egress tunnel router (ETR), functionality and using a LISP map server and map resolver for mapping services:

```
Device> enable
Device# configure terminal
Device(config)# vrf definition VRF1
Device(config-vrf)# address-family ipv4
Device(config-vrf-af)# exit
Device(config-vrf)# exit
Device(config)# ip multicast-routing vrf VRF1 [distributed]
Device(config)# ip pim vrf VRF1 ssm range LIST1
Device(config)# router lisp 22
Device(config-router-lisp)# eid-table vrf VRF1 instance-id 10
Device(config-router-lisp-eid-table)# database-mapping 198.51.100.0/24 192.0.2.10 priority
 1 weight 100
Device(config-router-lisp-eid-table)# exit
Device(config-router-lisp)# ipv4 itr
Device(config-router-lisp)# ipv4 etr
Device(config-router-lisp)# ipv4 itr map-resolver 192.0.2.10
Device(config-router-lisp)# ipv4 etr map-server 192.0.2.10 key 0 some-key
Device(config-router-lisp)# exit
Device(config)# interface lisp 22.10
Device(config-if)# ip pim sparse-mode
Device(config-if)# exit
Device(config)# ip route 0.0.0.0 0.0.0.0 192.0.2.20
Device(config)# end
```

Additional References for LISP Multicast

The following sections provide references related to the Locator ID Separation Protocol.

Related Documents

Document Title	Location
Cisco IOS commands	Cisco IOS Master Command List, All Releases
LISP commands	Cisco IOS IP Routing: LISP Command Reference

Standards

Standard	Title
Address family numbers	IANA Address Family Numbers

MIBs

MIB	MIBs Link
None	To locate and download MIBs for selected platforms, Cisco IOS software releases, and feature sets, use Cisco MIB Locator found at the following URL: http://www.cisco.com/go/mibs

RFCs

RFC	Title
RFC 6830	Locator/ID Separation Protocol (LISP) http://tools.ietf.org/html/
RFC 6831	LISP Multicast http://tools.ietf.org/html/rfc6831
RFC 6832	Interworking LISP and Non-LISP Sites http://tools.ietf.org/html/rfc6832
RFC 6833	LISP Map Server Interface http://tools.ietf.org/html/rfc6833
RFC 6834	LISP Map-Versioning http://tools.ietf.org/html/rfc6834
RFC 6835	LISP Internet Groper http://tools.ietf.org/html/rfc6835
RFC 6836	LISP Alternative Topology (LISP+ALT) http://tools.ietf.org/html/rfc6836

Technical Assistance

Description	Link
<p>The Cisco Support website provides extensive online resources, including documentation and tools for troubleshooting and resolving technical issues with Cisco products and technologies.</p> <p>To receive security and technical information about your products, you can subscribe to various services, such as the Product Alert Tool (accessed from Field Notices), the Cisco Technical Services Newsletter, and Really Simple Syndication (RSS) Feeds.</p> <p>Access to most tools on the Cisco Support website requires a Cisco.com user ID and password.</p>	<p>http://www.cisco.com/cisco/web/support/index.html</p>

Feature Information for LISP Multicast

The following table provides release information about the feature or features described in this module. This table lists only the software release that introduced support for a given feature in a given software release train. Unless noted otherwise, subsequent releases of that software release train also support that feature.

Use Cisco Feature Navigator to find information about platform support and Cisco software image support. To access Cisco Feature Navigator, go to www.cisco.com/go/cfn. An account on Cisco.com is not required.

Table 1: Feature Information for LISP Multicast

Feature Name	Releases	Feature Information
LISP Multicast		<p>The LISP Multicast feature introduces support for carrying multicast traffic over a Locator ID Separation Protocol (LISP) overlay and allows source multicast sites and receiver multicast sites to send and receive multicast packets over a unicast RLOC core.</p>

