



CHAPTER 2

Cisco Multi-purpose Integrated Antenna (ANT-MP-INT-OUT-M)

The Cisco Multipurpose Integrated Antenna is designed to cover domestic frequencies from 806 to 960 MHz and 1710 to 2700 MHz. It is supported on the Cisco CGR 1240 router.

This antenna is designed for direct mounting on the CGR1240 and has an MCX connector.



Caution

Read the information in [Safety Precautions, page 1-25](#) before installing or replacing antennas.

This chapter covers the following topics:

- [Technical Specifications, page 2-1](#)
- [Integrated Antenna Kit, page 2-14](#)
- [Safety Warnings, page 2-15](#)
- [Antenna Installation, page 2-17](#)
- [Obtaining Documentation and Submitting a Service Request, page 2-20](#)

Technical Specifications

The Multi-purpose Integrated Antenna features the following:

- Indoors and outdoors
- Low-profile housing
- Adjustable mounting brackets
- Supports 3G and 4G

Figure 2-1 Monopole Antenna

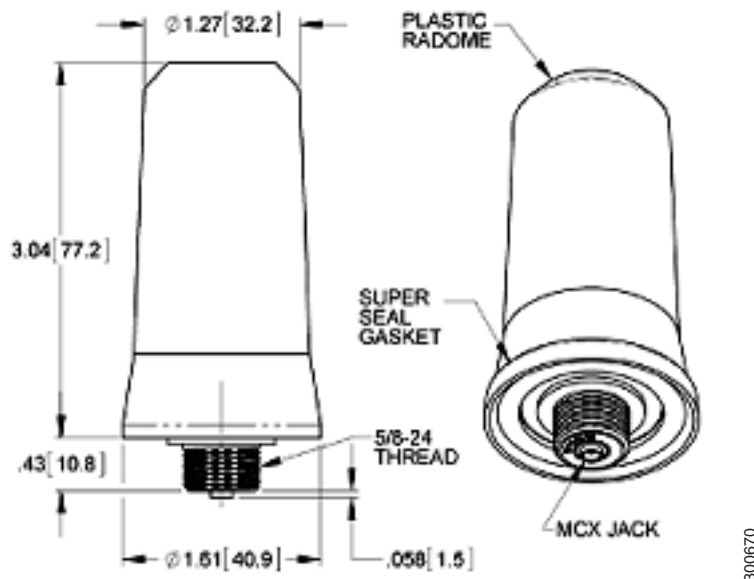

RF Specifications

The following is a summary of the monopole Radio Frequency (RF) antenna specifications:

| Specification | Cisco Connected Grid Monopole Antennas |
|--|--|
| Operating frequency range | 806 to 960 MHz 1710 to 2170 MHz 2300 to 2700 MHz |
| VSWR | 2:1 max |
| Peak gain 806 to 960 MHz | 2.8 dBi |
| Peak gain 1710 to 2170 MHz | 3.5 dBi |
| Peak gain 2300 to 2700 MHz | 4.0 dBi |
| Average gain @15 degrees elevation 806 to 960 MHz | 0.0 dBi +/- 1.0 dB |
| Average gain @15 degrees elevation 1710 to 2170 MHz | 1.0 dBi +/- 1.0 dB |
| Average gain @15 degrees elevation 2300 to 2700 MHz | 2.5 dBi +/- 1.0 dB |
| Efficiency 806 to 960/1710 to 2170/2300 to 2700 MHz: | 60% minimum |
| Polarization | Vertical -3 dB beamwidth |
| Horizontal plane | Omni |
| Vertical plane 806 to 960 MHz | 59 degrees average |
| Vertical plane 1710 to 2170 MHz | 46 degrees average |
| Vertical plane 2300 to 2700 MHz | 40 degrees average |

| Specification | Cisco Connected Grid Monopole Antennas |
|--------------------|--|
| Power withstanding | 10 W |
| Connector type | MCX jack |

Mechanical Specifications

The following is a summary of the monopole antenna specifications:

| Specification | Description |
|-----------------------|--|
| Plastic radome | PC/polyester blend, Makroblend EL 703, .110 think min. |
| Flammability | UL94 V-0 |
| Color | Cisco gray |
| Ingress protection | IP67 |
| Weight | 90 g |
| Wind-loading | 165 MPH |
| Overall length | 3.04 inches |
| Installation torque | 6 to 9 ft/lbs |
| Installation tool | Recommended strap wrench, similar to McMaster Car P/N: 5448A31 |
| Operating temperature | -40 to 185 degrees F (-40 to 85 degrees C) |

Radiation Patterns

All radiation patterns, gain, and VSWR are measured with the antenna mounted at the center of a 12-by-12-inch ground plane.

Figure 2-2 Radiation Pattern—Vertical Plane

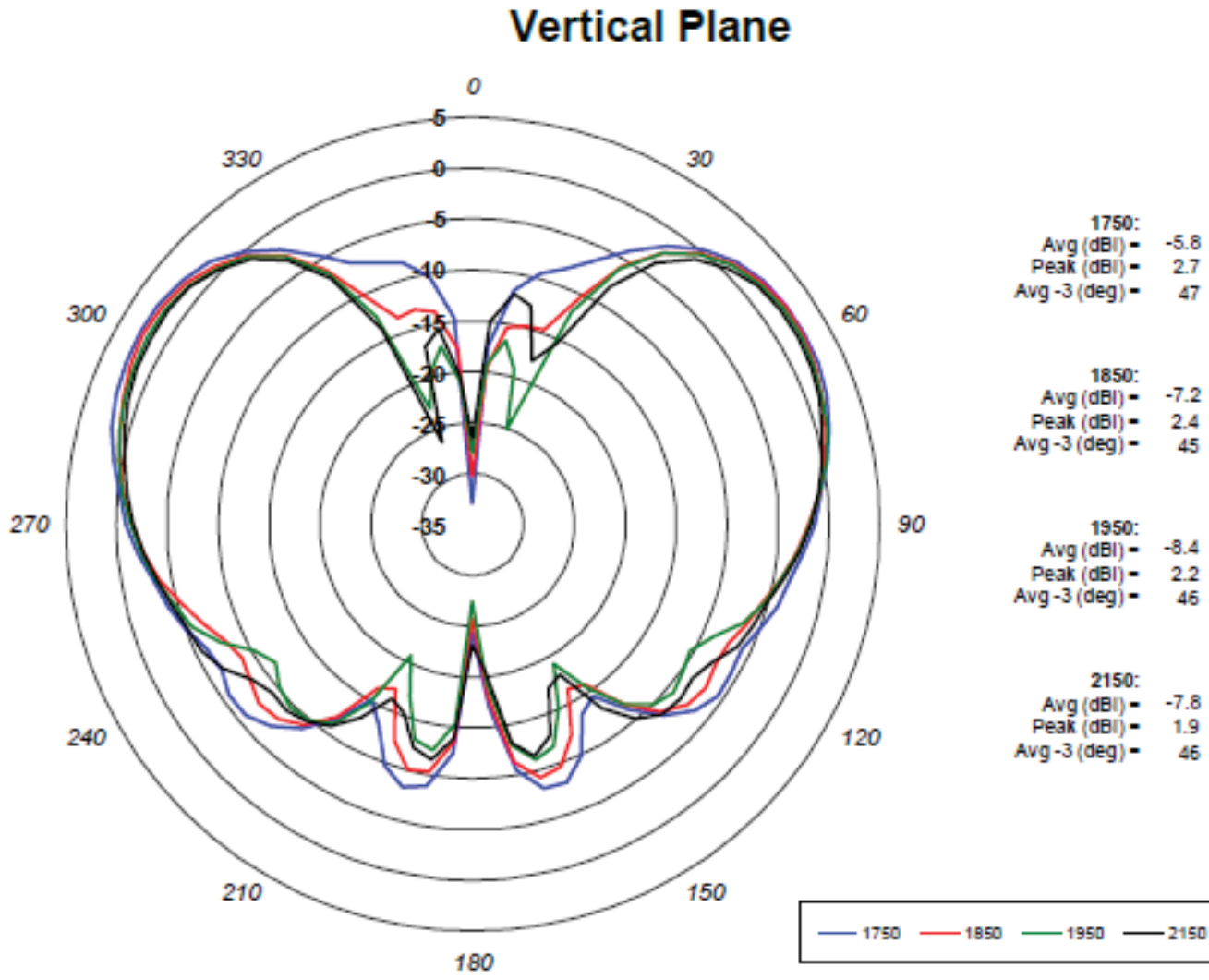
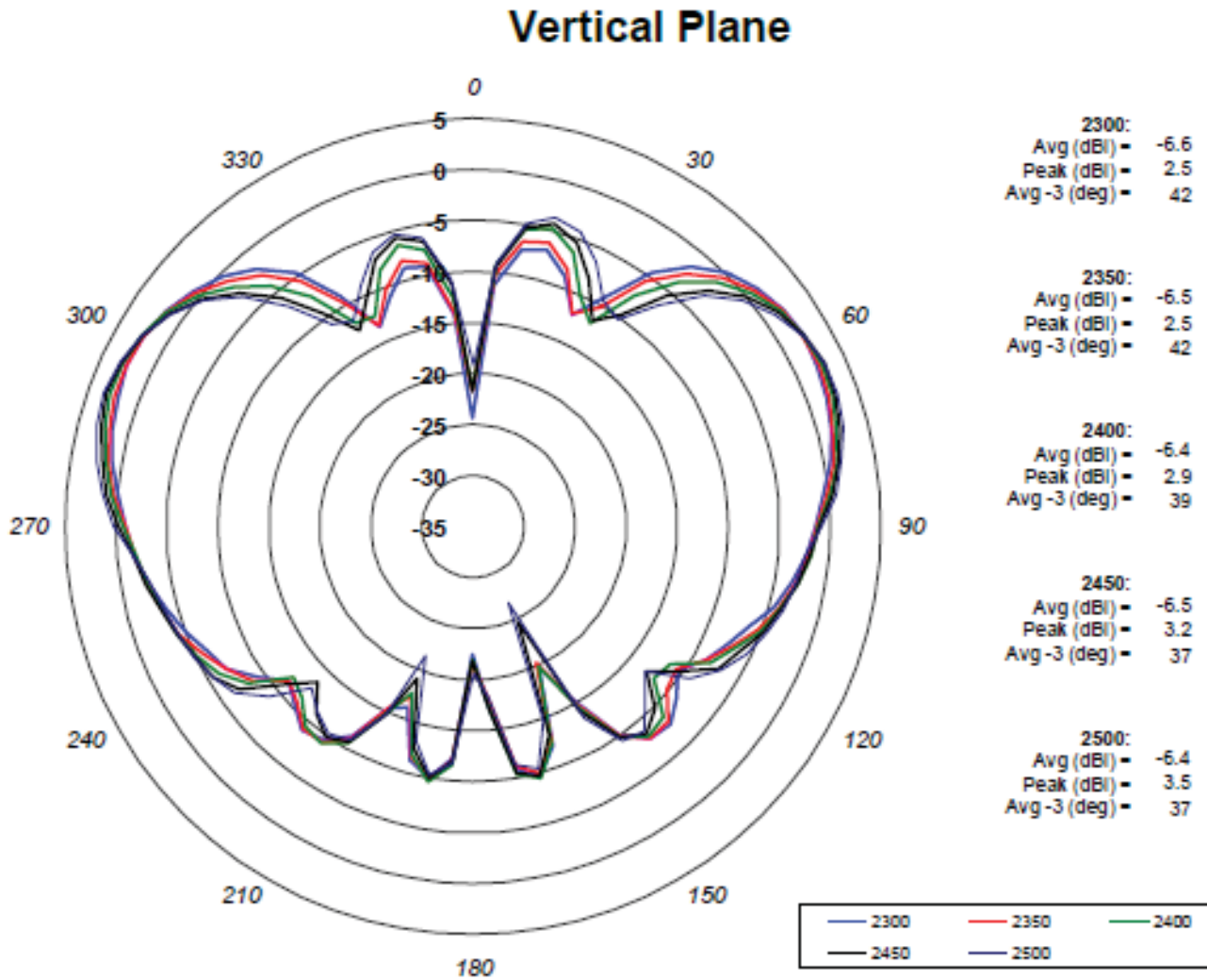
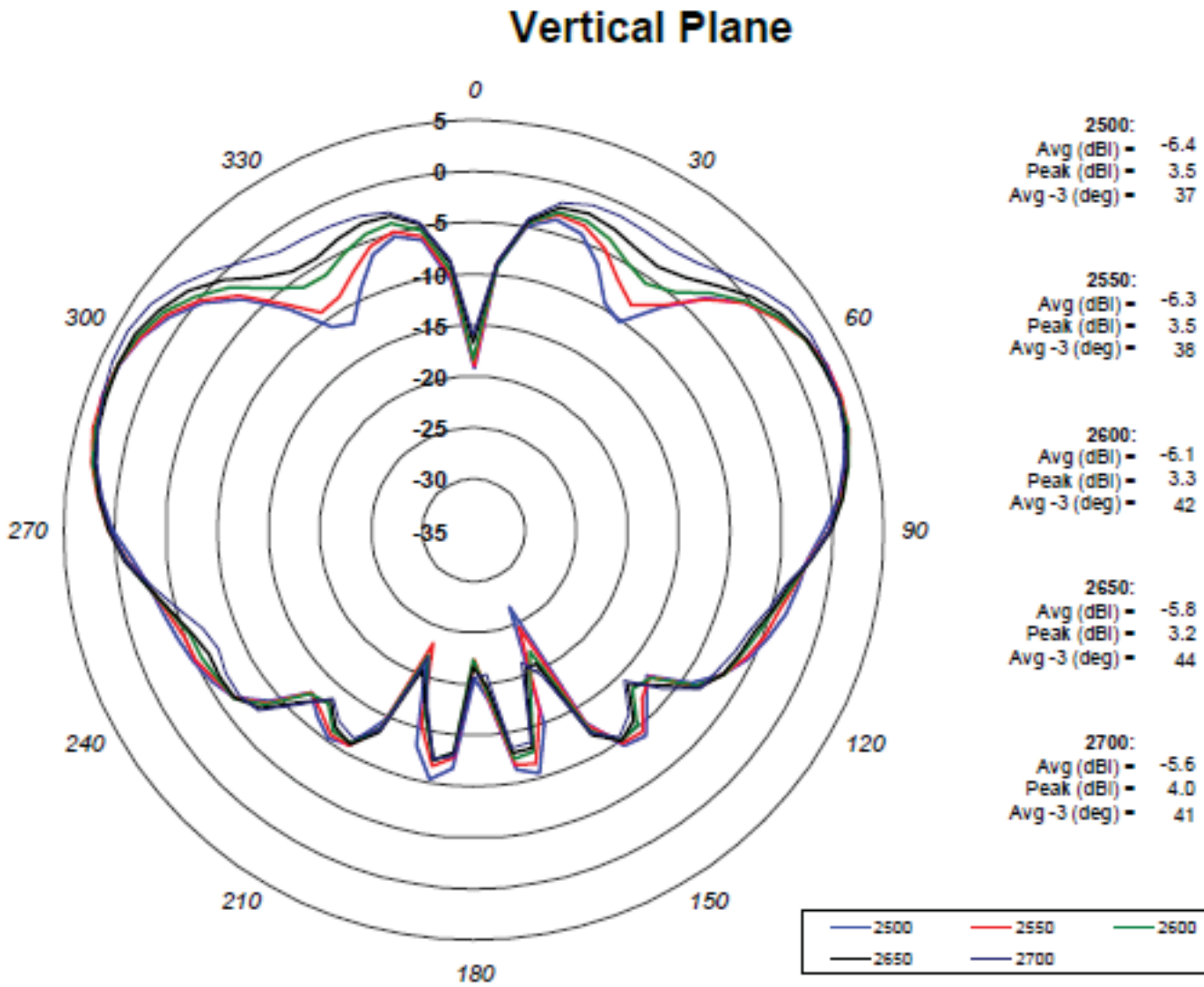

Figure 2-3 Radiation Pattern—Vertical Plane



300659

Figure 2-4 Radiation Pattern—Vertical Plane



300060

Figure 2-5 Radiation Pattern—Horizontal Plane

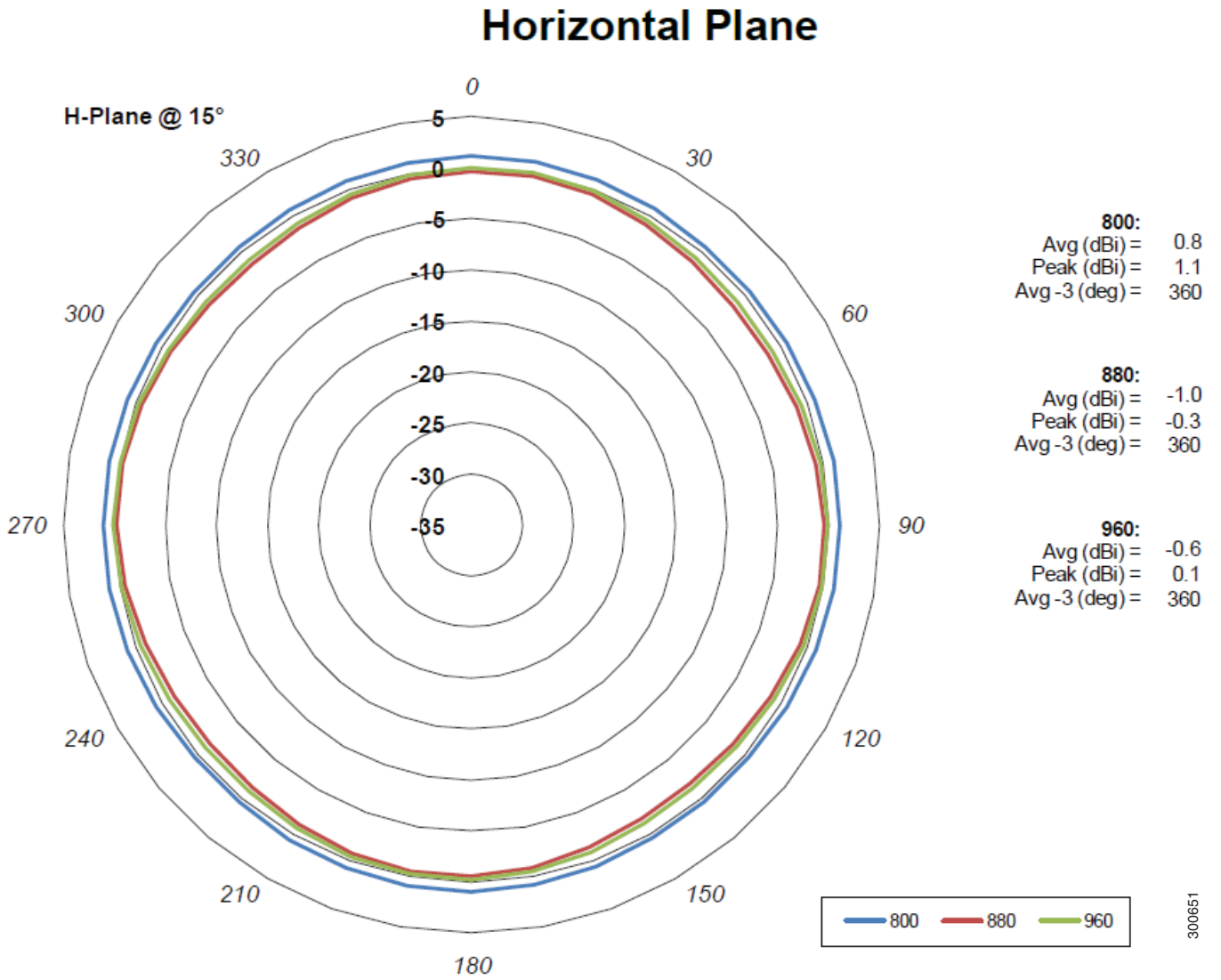
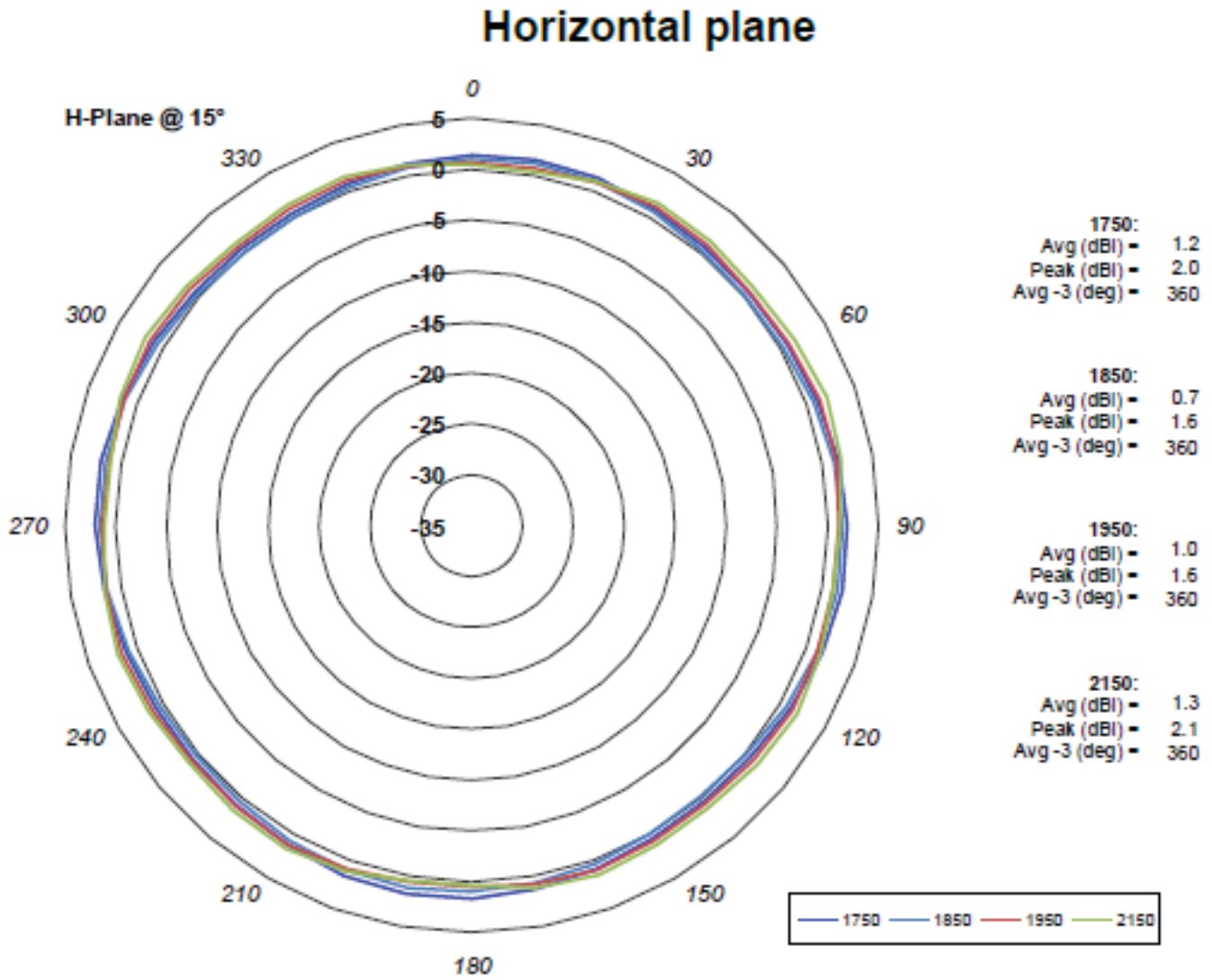

Figure 2-6 Radiation Pattern—Horizontal Plane



300652

Figure 2-7 Radiation Pattern—Horizontal Plane

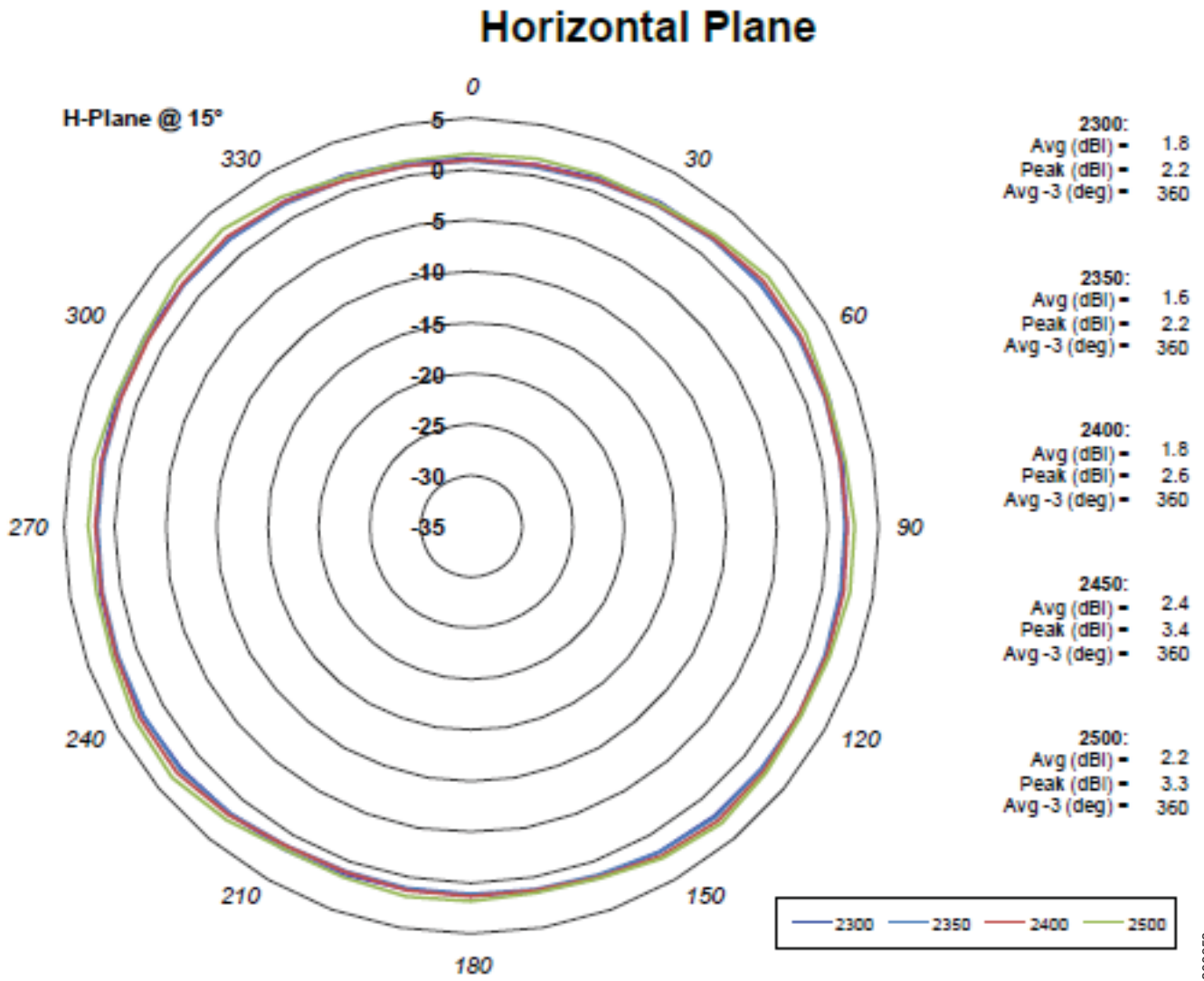

Figure 2-8 Radiation Pattern—Horizontal Plane

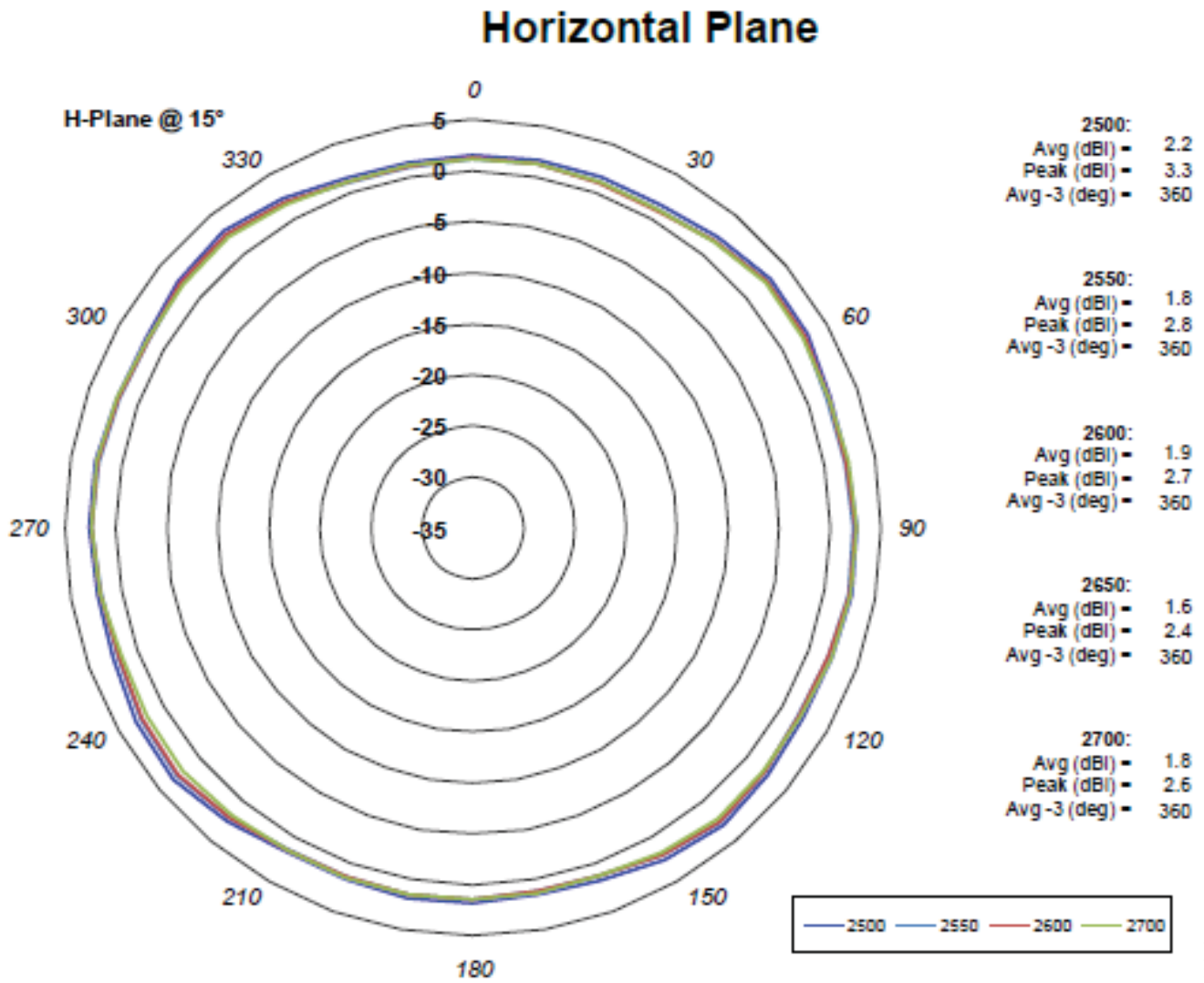
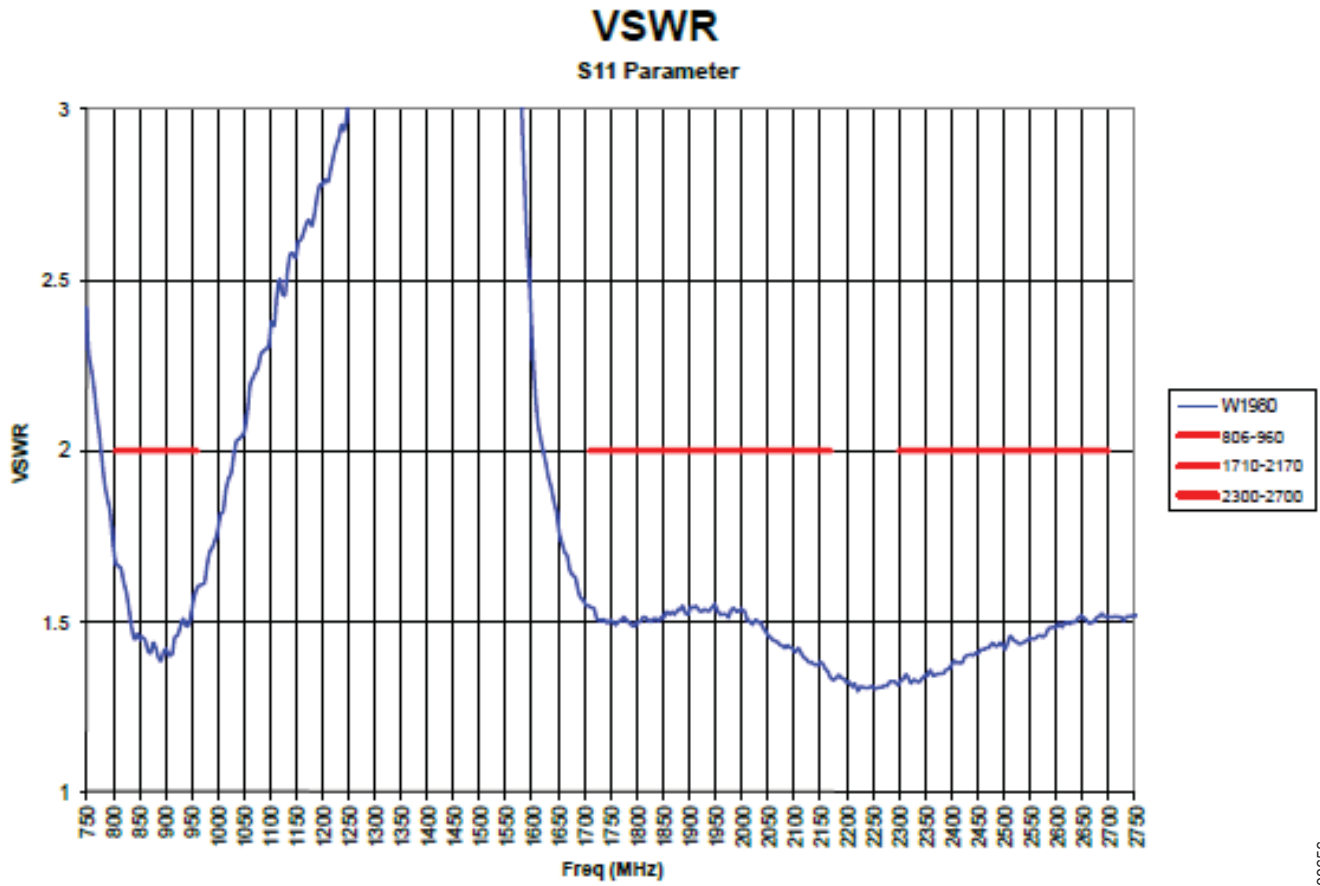

Figure 2-9 Radiation Pattern—VSWR



300656

Figure 2-10 Radiation Pattern—Peak Gain

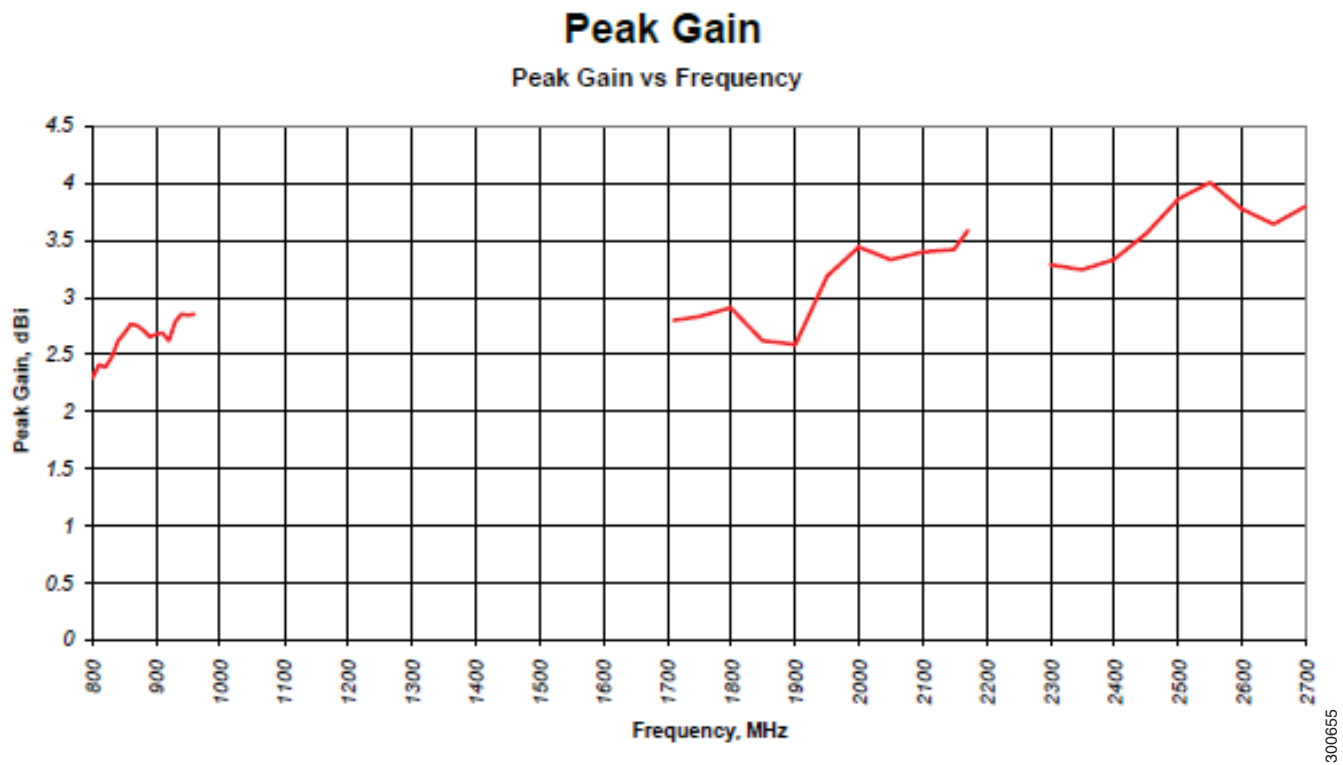
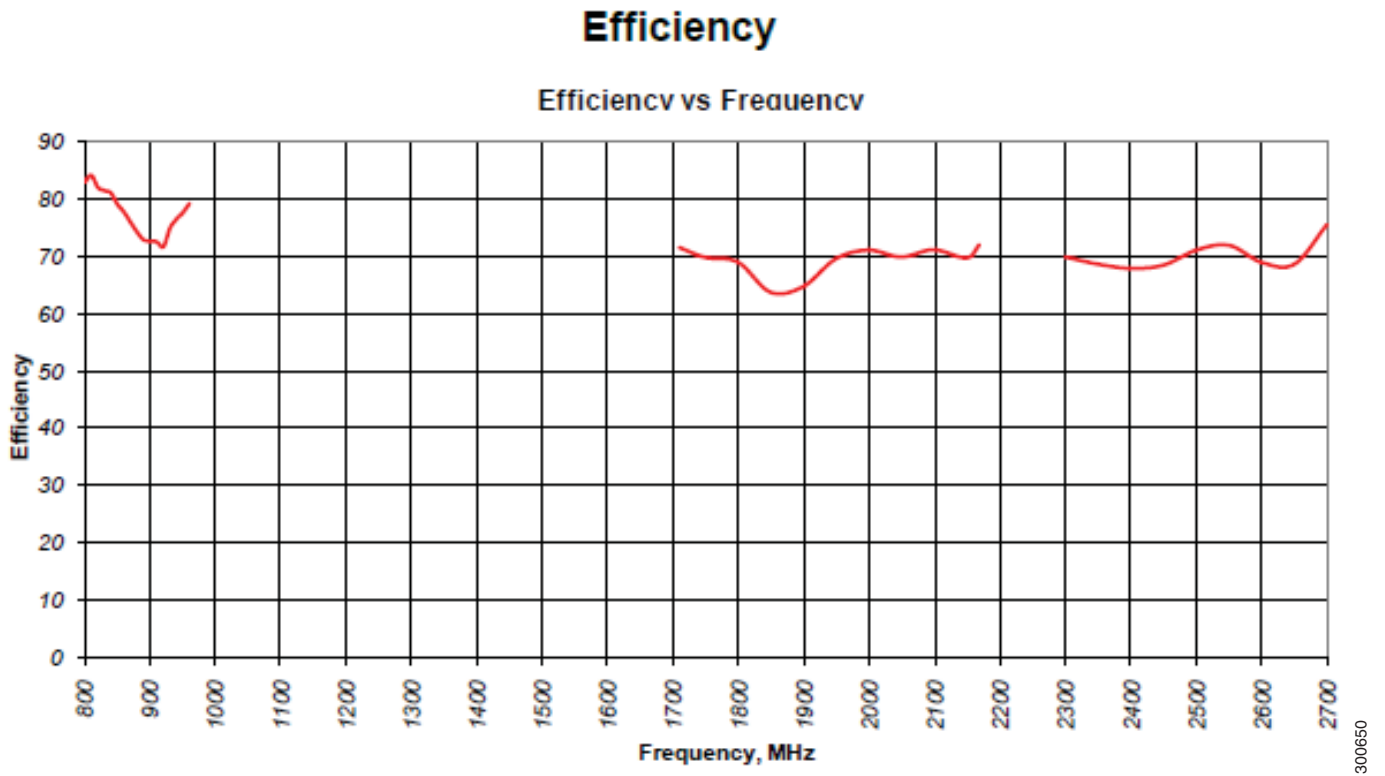

Figure 2-11 Radiation Pattern—Efficiency



300650

Integrated Antenna Kit

The multi-purpose integrated antenna is shown here but the kit is identical for all antenna models.

Figure 2-12 Antenna Kit

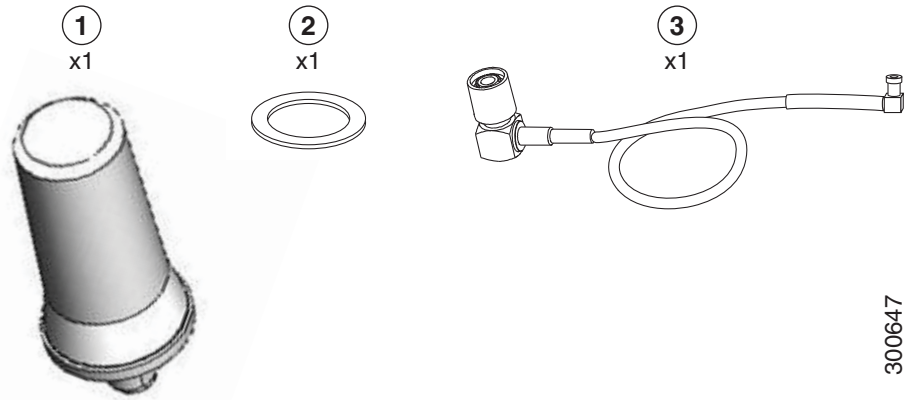

| | | | |
|---|---|---|---------------|
| 1 | Module antenna, with integrated coaxial cable | 2 | Rubber gasket |
| 3 | Cable | | |

Integrated Antenna End Kit Inventory

The multi-purpose integrated antenna kit is identical for all antenna models.

- Antenna-to-module coaxial cable (MCX-to-QMA, 10.5")
- Coax seal
- Tie wrap

Mounted Antenna End Kit Inventory

- N-connector
- Weather-proof coaxial seal
- Electrical joint compound
- Universal MCX-to-QMA cable (10.5")
- Tie wraps
- Cap

Safety Warnings



Avoid using or servicing any equipment that has outdoor connections during an electrical storm. There may be a risk of electric shock from lightning. Statement 1088



Do not work on the system, or connect or disconnect cables, during periods of lightning activity. Statement 1001



Do not locate the outdoor antenna near overhead power lines or other electric light or power circuits, or where it can come into contact with such circuits. When installing the antenna, take extreme care not to come into contact with such circuits, as they may cause serious injury or death. For proper installation and grounding of the antenna, please refer to national and local codes (for example, U.S.:NFPA 70, National Electrical Code, Article 810, Canada:Canadian Electrical Code, Section 54). Statement 1052



Do not work on the system or connect or disconnect cables during periods of lightning activity. Statement 1001



This equipment must be grounded. Never defeat the ground conductor or operate the equipment in the absence of a suitably installed ground conductor. Contact the appropriate electrical inspection authority or an electrician if you are uncertain that suitable grounding is available. Statement 1024



Only trained and qualified personnel should be allowed to install, replace, or service this equipment. Statement 1030



To report a gas leak, do not use a telephone in the vicinity of the leak. Statement 1039



This warning symbol means danger. You are in a situation that could cause bodily injury. Before you work on any equipment, be aware of the hazards involved with electrical circuitry and be familiar with standard practices for preventing accidents. Use the statement number provided at the end of each warning to locate its translation in the translated safety warnings that accompanied this device. Statement 1071. **SAVE THESE INSTRUCTIONS.**



This product is not intended to be directly connected to the Cable Distribution System. Additional regulatory compliance and legal requirements may apply for direct connection to the Cable Distribution System. This product may connect to the Cable Distribution System ONLY through a device that is approved for direct connection. Statement 1078

Safety Instructions

Each year hundreds of people are killed or injured when attempting to install an antenna. In many of these cases, the victim was aware of the danger of electrocution, but did not take adequate steps to avoid the hazard.

For your safety, and to help you achieve a good installation, please read and follow these safety precautions. **They may save your life!**

For your safety, read and follow these safety precautions.



Warning

In order to comply with FCC radio frequency (RF) exposure limits, antennas should be located at a minimum of 7.9 inches (20 cm) or more from the body of all persons. Statement 332

- If you are installing an antenna for the first time, for your own safety as well as others, seek professional assistance. Your Cisco sales representative can explain which mounting method to use for the size and type antenna you are about to install.
- Plan your installation procedure carefully and completely before you begin.
- Choose your installation site with safety performance in mind. Remember that electric power cables and telephone lines look alike. For your safety, assume that any line is an electric power line until determined otherwise.
- Call your local power company or building maintenance organization if you are unsure about cables close to your mounting location.
- When installing your antenna, do not use a metal ladder. Dress in rubber soled shoes and heels, rubber gloves, and a long-sleeved shirt or jacket.
- If an accident or emergency occurs with the power lines, call for qualified emergency help immediately.
- Before you install an antenna, contact your Cisco account representative to explain which mounting method to use for the size and type of antenna that you are about to install.
- Find someone to help you—installing an antenna is often a two-person job.
- Select your installation site with safety, as well as performance, in mind. Remember that electric power lines and phone lines look alike. For your safety, assume that any overhead line can kill you.
- Contact your electric power company. Tell them your plans and ask them to come look at your proposed installation.
- Each person involved in an installation should be assigned to a specific task, and should know what to do and when to do it. One person should be in charge of the operation to issue instructions and watch for signs of trouble.
- If the assembly starts to drop, move away from it and let it fall. Because the antenna, mast, cable, and metal guy wires are all excellent conductors of electrical current, even the slightest touch of any of these parts to a power line completes an electrical path through the antenna and the installer.
- If any part of the antenna system should come in contact with a power line, do not touch it or try to remove it yourself. Call your local power company to have it removed safely.
- If an accident occurs with the power lines, call for qualified emergency help immediately.

Antenna Installation

This section covers the following topics:

- [Installation Notes, page 2-17](#)
- [Tools and Equipment Required, page 2-18](#)
- [Install the Antenna onto the CGR 1240 Router, page 2-18](#)

Installation Notes

This Cisco Multi-purpose Integrated Antenna is designed to be mounted directly onto the router.

In addition to antenna orientation, wireless access point installation location with respect to all wireless clients plays a significant role in determining overall network performance.

Because antennas transmit and receive radio signals, their performance can be adversely affected by the surrounding environment including distance between the Field Area Router (FAR) and cellular base station, physical obstructions, or radio frequency (RF) interference.

Follow these guidelines to ensure the best possible performance:

- Install the router with antenna without physical obstructions. Barriers along the line of sight between the FAR and cellular base station degrade the wireless radio signals.
- The density of the materials used in a building's construction determines the number of walls the signal must pass through and still maintain adequate coverage. Consider the following before choosing the location to install your antenna:
 - Paper and vinyl walls have very little effect on signal penetration.
 - Solid and precast concrete walls limit signal penetration to one or two walls without degrading coverage.
 - Concrete and wood block walls limit signal penetration to three or four walls.
 - A signal can penetrate five or six walls constructed of drywall or wood.
 - A thick metal wall or wire-mesh stucco walls causes signals to reflect back and cause poor penetration.
- Avoid mounting the antenna next to a column or vertical support that could create a shadow zone and reduce the coverage area.
- Keep the antenna away from reflective metal objects such as heating and air-conditioning ducts, large ceiling trusses, building superstructures, and major power cabling runs. If necessary, use an extension cable to relocate the antenna away from these obstructions.

**Caution**

Install the router and antenna away from appliances that share the same frequency bands. Microwave ovens, cordless telephones, and security monitors can temporarily interfere with wireless performance.

**Caution**

Avoid installing wireless antennas in or near rack-mounted installations that include networking equipment and computer servers whose radiated noise emissions can severely degrade radio performance.

**Note**

If the desired installation site has a marginally acceptable level of radiated noise emissions, consider using a remote-mounted antenna, such as a wall-mount or ceiling-mount antenna, for better radio performance and coverage.

Tools and Equipment Required

In addition to the parts included in the antenna kit described in the section [Integrated Antenna Kit, page 2-14](#), you must provide the following tool to install the antenna on the router:

- Strap wrench
- 13 mm socket wrench

Install the Antenna onto the CGR 1240 Router

For a list of supported ports on the CGR 1240, see [Antenna Ports, page 1-29](#) of [Chapter 1, “Cisco CGR 1000 and 2000 Series Connected Grid Antennas Overview”](#).

Follow these steps to install the antenna onto the router:

-
- Step 1** Remove the plug on the antenna connector if one is present.
- Step 2** Attach the monopole antenna to your desired antenna port. Do not tighten the antenna completely—stop tightening so that the antenna is not fully installed.

Figure 2-13 Insert Base of Antenna into Router Antenna Port

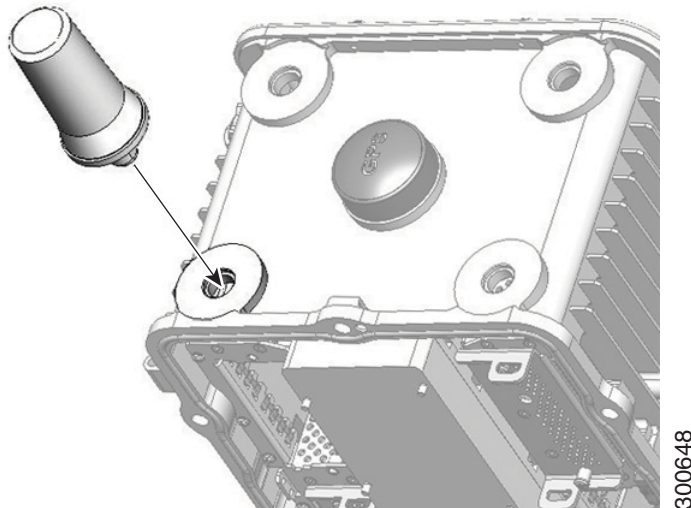

300648

Step 3 From the chassis interior, the antenna MCX jack should be visible in the plug. With one hand, position the right-angle end of the antenna cable to the antenna's MCX jack. With your other hand, push the cable end so it inserts into the MCX jack of the antenna.

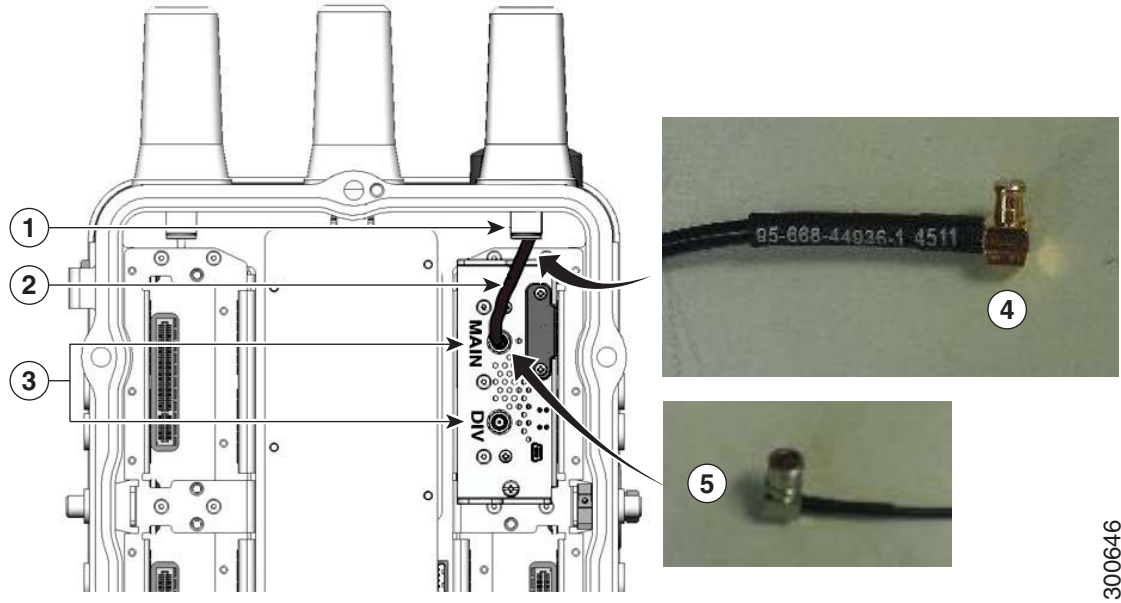

300646

| | | | |
|---|---|---|---|
| 1 | Antenna base | 2 | Antenna-to-router coaxial antenna cable (with QMA-male connector) |
| 3 | Connected Grid module coaxial connectors (QMA-female) | 4 | MCX end |
| 5 | QMA end | | |

Step 4 From the exterior of the router, tighten the antenna using the torque wrench. Tighten to 6 to 7 ft-lbs.

Step 5 From the interior of the router, install the coaxial end of the cable to the appropriate connector on your installed module. The antenna and module ports should be the same color (red, yellow, or green). For more information, see [Antenna and CG Module Color Codes, page 1-35 in Cisco CGR 1000 and 2000 Series Connected Grid Antennas Overview](#).



Note Some modules require two antennas: a main antenna and a diversity antenna. These modules have two antenna connectors on the front panel, labeled MAIN and DIV. Be sure to connect the main and diversity antennas to the correct module connectors.

Obtaining Documentation and Submitting a Service Request

For information on obtaining documentation, submitting a service request, and gathering additional information, see the monthly What's New in Cisco Product Documentation, which also lists all new and revised Cisco technical documentation, at:

<http://www.cisco.com/en/US/docs/general/whatsnew/whatsnew.html>

Subscribe to the *What's New in Cisco Product Documentation* as an RSS (Really Simple Syndication) feed, and set it so content is delivered directly to your desktop using a reader application. The RSS feeds are a free service and Cisco currently supports RSS Version 2.0.

Cisco and the Cisco Logo are trademarks of Cisco Systems, Inc. and/or its affiliates in the U.S. and other countries. A listing of Cisco's trademarks can be found at www.cisco.com/go/trademarks. Third party trademarks mentioned are the property of their respective owners. The use of the word partner does not imply a partnership relationship between Cisco and any other company. (1005R)