



Cisco Aironet 4-dBi Omnidirectional Antenna (AIR-ANT5140V-R)

This document outlines the specifications, describes the AIR-ANT(AIR-ANT5140V-R) 4-dBi omnidirectional antenna, and provides instructions for mounting it.

The antenna is designed specifically for use with pre-802.11n and 802.11n 3-antenna access points. The antenna operates in the 5-GHz frequency range and is designed for use only in an indoor office environment. The antenna assembly consists of three radiating elements, each fed with its own coaxial cable.

The following information is provided in this document.

- [Technical Specifications](#)
- [System Requirements](#)
- [Safety Instructions](#)
- [Installation Notes](#)
- [Obtaining Documentation, Obtaining Support, and Security Guidelines](#)

Technical Specifications

Antenna type	Omnidirectional, indoor office only
Operating frequency range	4900 – 5850 MHz
Nominal input impedance	50 ohms
1.5:1 VSWR bandwidth	4900 – 5850 MHz
Peak gain	4 dBi
Polarization	Linear
E-plane 3 dB beamwidth	45 degrees
H-plane 3 dB beamwidth	Omnidirectional
Front-to-back ratio	10 dB
Length	6.9 in. (17.5 cm)
Width	3 in. (7.6 cm)
Height	< 1 in (< 2.5 cm)
Cable length and type	36 in. (91.4 cm) Plenum rated, UV stable
Operating temperature	32 F – 131 F (0 C – 55 C)

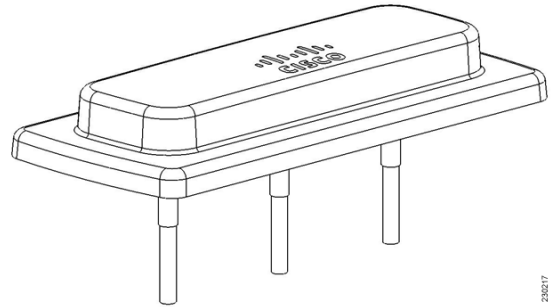

Antenna A Elevation and Azimuth Pattern

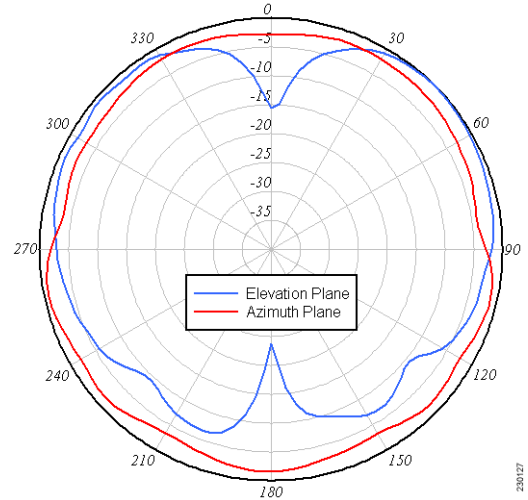

Antenna C Elevation and Azimuth Pattern

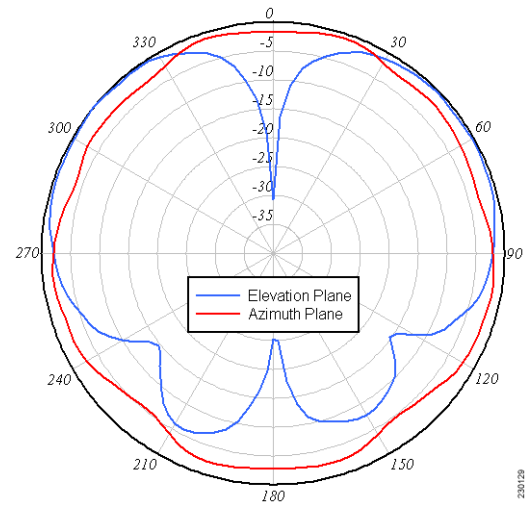

Antenna B Elevation and Azimuth Pattern

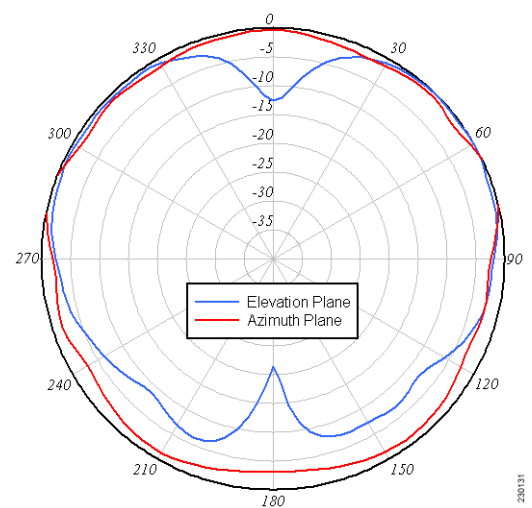

System Requirements

This antenna is designed for indoor use with pre-802.11n and 802.11n Cisco Aironet access points.

Safety Instructions

Follow these safety instructions when installing your antenna.

- Plan your installation procedure carefully and completely before you begin.
- If you are installing an antenna for the first time, for your own safety as well as others, seek **professional assistance**. Consult your dealer, who can explain which mounting method to use for the location where you intend to install the antenna.
- Select your installation site with safety, as well as performance, in mind. Remember that electric power cables and telephone lines look alike. For your safety, assume that any line is an electric power line until determined otherwise.

- Call your local power company or building maintenance organization if you are unsure about cables close to your mounting location.
- When installing your antenna, **do not** use a metal ladder. **Do** dress properly: shoes with rubber soles and heels, rubber gloves, and a long sleeved shirt or jacket.
- If an accident or emergency occurs with the power lines, call for qualified emergency help immediately.

Installation Notes

Because antennas transmit and receive radio signals, they are susceptible to RF obstructions and common sources of interference that can reduce throughput and range of the device to which they are connected. Follow these guidelines to ensure the best possible performance:

- Mount the antenna to utilize its propagation characteristics. A way to do this is to orient the antenna horizontally as high as possible at or near the center of its coverage area.
- Keep the antenna away from metal obstructions such as heating and air-conditioning ducts, large ceiling trusses, building superstructures, and major power cabling runs. If necessary, use a rigid conduit to lower the antenna away from these obstructions.
- The density of the materials used in a building's construction determines the number of walls the signal must pass through and still maintain adequate coverage. Consider the following before choosing the location to install your antenna:
 - Paper and vinyl walls have very little affect on signal penetration.
 - Solid and pre-cast concrete walls limit signal penetration to one or two walls without degrading coverage.
 - Concrete and wood block walls limit signal penetration to three or four walls.
 - A signal can penetrate five or six walls constructed of drywall or wood.
 - A thick metal wall causes signals to reflect off, causing poor penetration.
 - A chain-link fence or wire mesh spaced between 1 and 1 1/2 in. (2.5 and 3.8 cm) acts as a harmonic reflector that blocks a 5-GHz radio signal.
- Install the antenna away from microwave ovens and 5-GHz cordless phones. These products can cause signal interference because they operate in the same frequency range as the device to which your antenna is connected.
- Install the antenna horizontally to maximize signal propagation.

Choosing a Mounting Location

The antenna should be mounted clear of any obstructions to the sides of the radiating element. Generally, the higher an antenna is above the ground, the better it performs. If possible, find a mounting place directly above your wireless device so that the lead-in cable can be as short as possible.

Installing the Antenna

You can install the antenna on the following dropped ceiling systems:

- Standard or recessed T-rail—15/16 in. (23.8 mm) or 9/16 in. (14.3 mm)
- Channel type T-rail—1/4 in (6.3 mm) or 1/2 in (12.7 mm)

You can also install the antenna above a dropped ceiling ceiling using a user-supplied bridge. The antenna ships with the necessary hardware to install it on a standard dropped ceiling already installed. To install the antenna on any other type of dropped ceiling listed above, you will need to use the mounting hardware contained in the supplied mounting hardware kit.

Mounting Hardware Kit Contents

The antenna ships with a hardware mounting kit containing the following items:

- Two recessed ceiling T-rail spacers

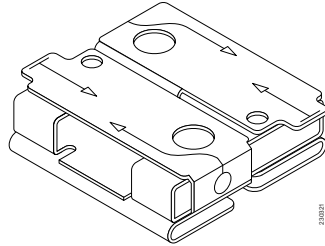

- Two channel ceiling rail adapters

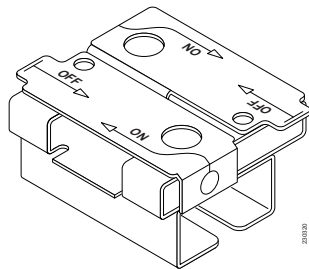

- Two bridge mounting clips

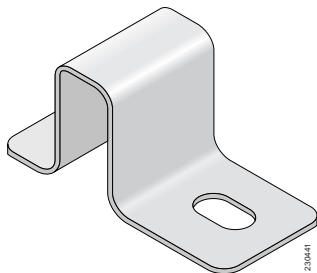

- Two 4x40 Phillips head machine screws

Making Connections to the Access Point

The antenna has three antenna connectors, one for each antenna element. Refer to the user documentation for the access point to which you are connecting the antenna for specific connection instructions.

Tools and Equipment Required

To install your antenna, you need the following tools and equipment, which are not supplied.

- A pencil
- A small standard screwdriver
- A cutting tool suitable for cutting and trimming dropped ceiling tiles

- Masking tape

Installing the Antenna on a Standard Dropped Ceiling T-Rail

The antenna is shipped ready to install on a standard dropped ceiling T-rail. No adapters or spacers are necessary. [Figure 1](#) shows the antenna installed on a standard dropped ceiling T-rail.

Figure 1 Antenna Installed on a Standard Dropped Ceiling T-Rail

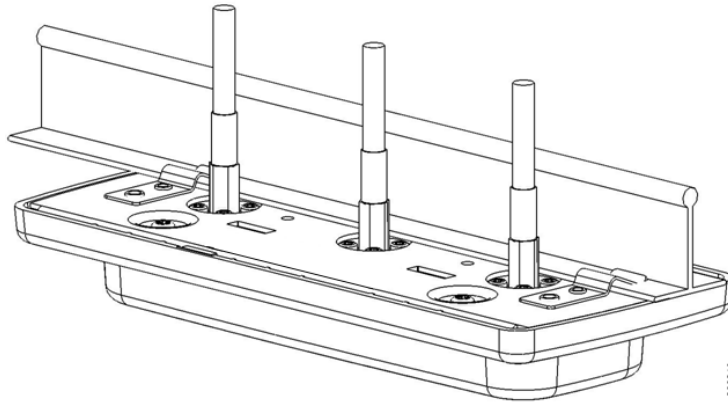

Follow these steps to install the antenna on a standard dropped ceiling T-rail.

1. Identify the location where you intend to install the antenna.
2. Looking at the T-rail, raise ceiling tile on the left side of the T-rail.
3. Position the clips on the antenna on the T-rail.
4. Gently slide the antenna over the T-rail until it is secure.
5. Connect the antenna cable to the access point or extender cables.
6. Lower the ceiling tile onto the T-rail. The antenna cables will prevent you from lowering it completely.
7. Mark the places on the ceiling tile where they are obstructed by the antenna cables.
8. Cut notches in the ceiling tile to eliminate the obstruction. You should then be able to lower the ceiling tile onto the T-rail.

Installing the Antenna on a Recessed Dropped Ceiling T-Rail

To install the antenna on a recessed dropped ceiling requires using the two recessed ceiling spacers included in the mounting kit. These spacers attach to the recessed ceiling T-rail and must be disassembled before you can attach them. [Figure 2](#) shows the antenna installed on a recessed ceiling T-rail using the supplied recessed T-rail spacers.

Figure 2 Antenna Installed on a Recessed Dropped Ceiling T-Rail

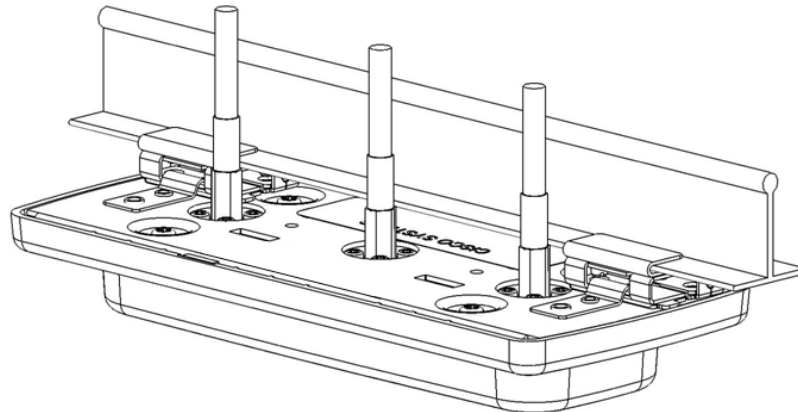

Follow these steps to install the antenna on a recessed dropped ceiling T-rail.

1. Identify the location where you intend to install the antenna.
2. Use a pencil to make an index mark at the locations on the T-rail where you will install the dropped ceiling spacers.

NOTE: These marks indicate the center points of the spacers and must be 10 3/16 in. (24.8 cm) apart.

3. In the mounting kit, locate two recessed dropped ceiling spacers.

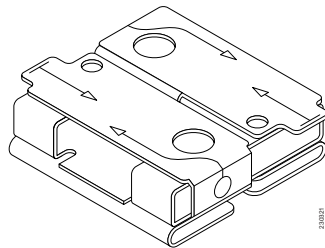

4. Disassemble the spacers by pushing on its tabs (1) using your thumb and forefinger.

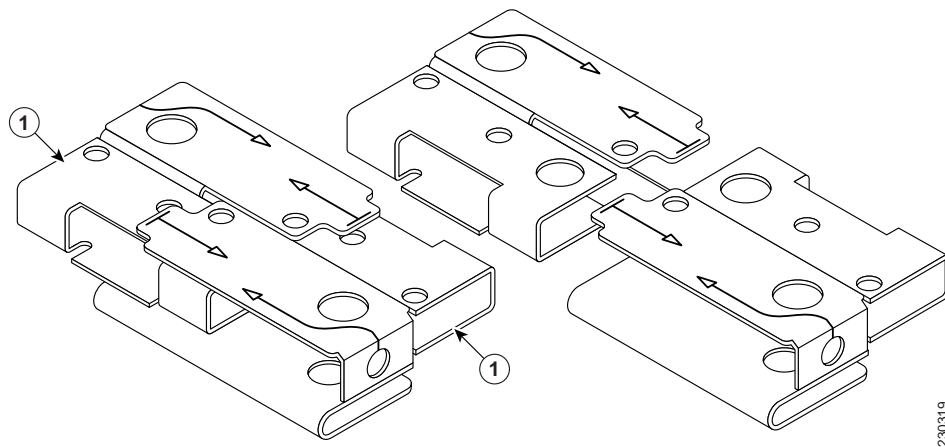

5. Raise the ceiling tile off the T-rail and position both pieces of the spacer on the T-rail (callout 1), one part on one side and the other on the opposite side. Make sure the ON arrows on the spacer parts point towards each other as shown above. The OFF arrows will point away from each other.

6. Position the spacers so that each one is centered over the index marks you made in Step 2.
7. Use a small standard screwdriver to tighten the two set screws on the spacers and secure the spacers to the T-rail. Do not overtighten the set screws.
8. Connect the antenna cable to the access point or extender cables.
9. Lower the ceiling tile onto the T-rail. Depending on the width of the T-rail, you may have to squeeze the tile to make it fit onto the T-rail.

Installing the Antenna on a Channel Ceiling T-Rail

To install the antenna on a recessed dropped ceiling requires using the two channel ceiling adapters included in the mounting kit. These adapters attach to the channel ceiling T-rail and must be disassembled before you can attach them. [Figure 3](#) shows the antenna installed on a channel ceiling T-rail using the supplied channel T-rail spacers.

Figure 3 Antenna Installed on a Channel Ceiling T-Rail

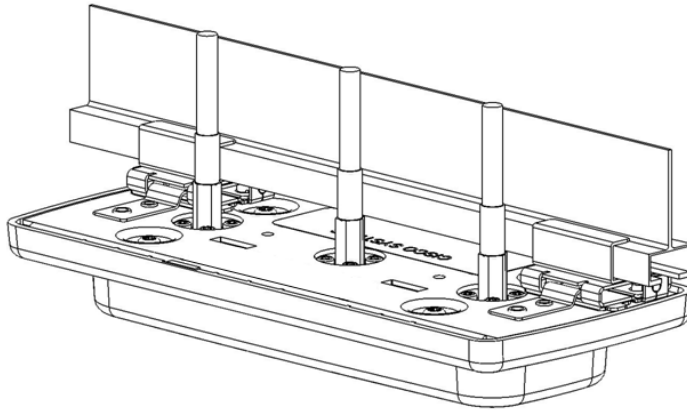

Follow these steps to install the antenna on a channel ceiling T-rail.

1. Identify the location where you intend to install the antenna.
2. Use a pencil to make an index mark at the locations on the T-rail where you will install the channel T-rail adapters.

NOTE: These marks indicate the center points of the adapters and must be 10 3/16 in. (24.8 cm) apart.

3. In the mounting kit, locate two recessed channel ceiling adapters.

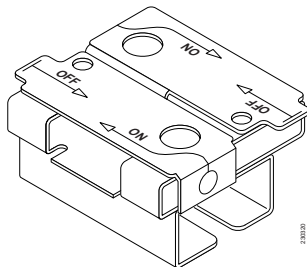

4. Disassemble each adapter by pushing on its tabs using your thumb and forefinger.

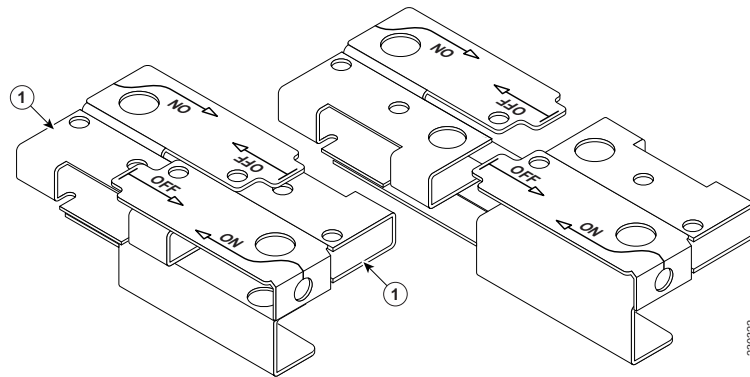

5. Raise the ceiling tile off the channel T-rail and position both pieces of the adapter on the T-rail (callout 1), one part on one side and the other on the opposite side. Make sure the ON arrows on the adapter parts are pointing towards each other as shown above. The OFF arrows will point away from each other.
6. Position the adapters so that each one is centered over the index marks you made in Step 2.
7. Use a small standard screwdriver to tighten the two set screws on the adapters and secure them to the channel T-rail. Do not overtighten the set screws.
8. Connect the antenna cable to the access point or extender cables.
9. Lower the ceiling tile onto the T-rail.

Installing the Antenna Above a Suspended Ceiling

To install the antenna above a dropped ceiling requires using the two bridge clips and 4/40 Phillips head machine screws that shipped in the mounting kit. The clips attach the antenna to the ceiling bridge assembly and the screws secure the clips to the antenna.

You must supply the ceiling bridge. In order to ensure compatibility with the supplied bridge clips, we recommend using a Erico 512A or equivalent T-bar box hanger. [Figure 4](#) shows a typical dropped ceiling bridge assembly and [Figure 5](#) shows the antenna installed on a dropped ceiling bridge assembly.

Figure 4 Typical Dropped Ceiling Bridge Assembly

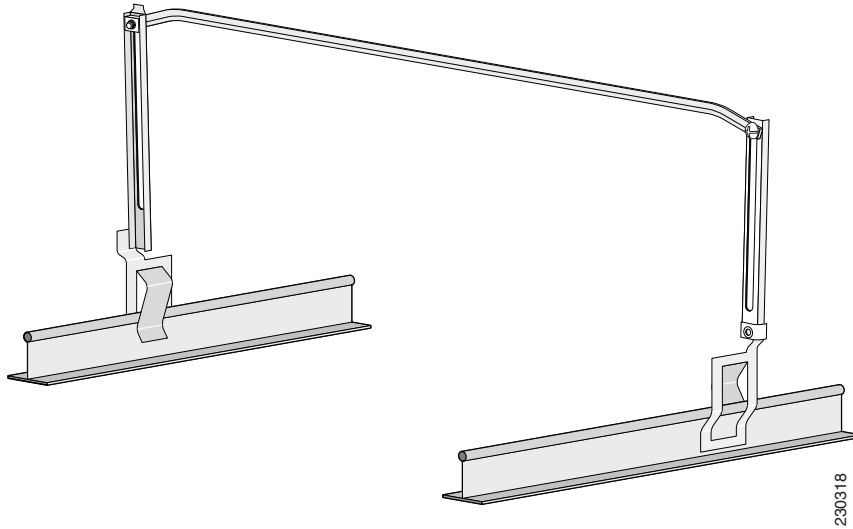
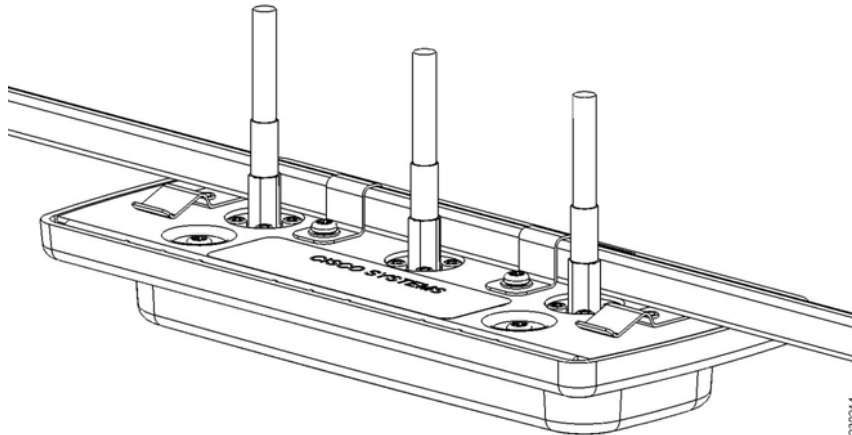

Figure 5 Antenna Installed on a Dropped Ceiling Bridge Assembly



Follow these steps to install the antenna above a suspended ceiling.

1. Identify the location in the ceiling where you want to install the antenna.
2. Remove the ceiling tiles adjacent to the T-rails where you will install the ceiling bridge assembly.
3. In the mounting kit, locate two bridge clips and 4x40 Phillips head screws.
4. Place the bridge clips on the bridge so that they are 2 3/8 in. (6.03 cm) apart.
5. Temporarily secure the clip to the bridge with a short length of masking tape.
6. Position the antenna so that the two rectangular slots are aligned with the clip tab that has no holes.
7. Carefully move the antenna so that the clip tabs are fully inserted into the rectangular slots.
8. Start a 4/40 Phillips head screw into each of the holes in the clip tabs.
9. Use a Phillips head screwdriver to secure, but not tighten, the screws.
10. Remove the masking tape from the clips.

11. Verify that the antenna is attached to the bridge where you want it to be. If it is not in the correct position, carefully slide the antenna until it is.
12. Tighten, but do not overtighten, the Phillips head screws.
13. Install the bridge in the ceiling.
14. Connect the antenna cables to the access point or extender cables.
15. Replace the ceiling tiles.

Suggested Cable

Cisco recommends a high-quality, low-loss cable for use with the antenna.

NOTE: Coaxial cable loses efficiency as the frequency increases, resulting in signal loss. The cable should be kept as short as possible because cable length also determines the amount of signal loss (the longer the run, the greater the loss).

Each antenna terminates with a RP-TNC plug after a short, 3-ft (0.91-m) cable. The mating connector to the antenna is an appropriate RP-TNC jack. The connector on the opposite end will vary according to the type of equipment used.

Obtaining Documentation, Obtaining Support, and Security Guidelines

For information on obtaining documentation, obtaining support, providing documentation feedback, security guidelines, and also recommended aliases and general Cisco documents, see the monthly *What's New* in Cisco Product Documentation, which also lists all new and revised Cisco technical documentation, at:

<http://www.cisco.com/en/US/docs/general/whatsnew/whatsnew.html>

CCVP, the Cisco Logo, and the Cisco Square Bridge logo are trademarks of Cisco Systems, Inc.; Changing the Way We Work, Live, Play, and Learn is a service mark of Cisco Systems, Inc.; and Access Registrar, Aironet, BPX, Catalyst, CCDA, CCDP, CCIE, CCIP, CCNA, CCNP, CCSP, Cisco, the Cisco Certified Internetwork Expert logo, Cisco IOS, Cisco Press, Cisco Systems, Cisco Systems Capital, the Cisco Systems logo, Cisco Unity, Enterprise/Solver, EtherChannel, EtherFast, EtherSwitch, Fast Step, Follow Me Browsing, FormShare, GigaDrive, GigaStack, HomeLink, Internet Quotient, IOS, iPhone, IP/TV, iQ Expertise, the iQ logo, iQ Net Readiness Scorecard, iQuick Study, LightStream, Linksys, MeetingPlace, MGX, Networking Academy, Network Registrar, *Packet*, PIX, ProConnect, RateMUX, ScriptShare, SlideCast, SMARTnet, StackWise, The Fastest Way to Increase Your Internet Quotient, and TransPath are registered trademarks of Cisco Systems, Inc. and/or its affiliates in the United States and certain other countries.

All other trademarks mentioned in this document or Website are the property of their respective owners. The use of the word partner does not imply a partnership relationship between Cisco and any other company. (0612R)

Any Internet Protocol (IP) addresses used in this document are not intended to be actual addresses. Any examples, command display output, and figures included in the document are shown for illustrative purposes only. Any use of actual IP addresses in illustrative content is unintentional and coincidental.

© 2017 Cisco Systems, Inc. All rights reserved.

 Printed in the USA on recycled paper containing 10% postconsumer waste.

