



# Prepare for Installation

---

Before you install the router, you must prepare your site for the installation.

Preparing your site involves these tasks:

- [Site Planning, on page 1](#)
- [Receive the Device, on page 8](#)

## Site Planning

The sections describe how to plan for the installation of the Cisco ASR 920 Series Router.

## General Precautions

Observe the following general precautions when using and working with your Cisco ASR 920 Router:

- Keep your system components away from radiators and heat sources and do not block cooling vents.
- Do not spill food or liquids on your system components and never operate the product in a wet environment.
- Do not push any objects into the openings of your system components. Doing so can cause fire or electric shock by shorting out interior components.
- Position system cables and power supply cable carefully. Route system cables and the power supply cable and plug so that they are not stepped on or tripped over. Be sure that nothing else rests on your system component cables or power cable.
- Do not modify power cables or plugs. Consult a licensed electrician or your power company for site modifications. Always follow your local and national wiring rules.
- If you turn off your system, wait at least 30 seconds before turning it on again to avoid damage of system components.

## Site Planning Checklist

Use the following checklist to carry out all site planning tasks:

- The site meets environmental requirements.
- The site's air conditioning system can compensate for the heat dissipation of the chassis.
- The floor space that the chassis occupies can support the weight of the system.

- Electrical service to the site complies with the safety with electricity requirements.
- The electrical circuit servicing the chassis complies with the power supply requirements.
- Console port wiring and cabling limitations have been considered in accordance to TIA/EIA-232F.
- The chassis Ethernet cabling distances are within prescribed limits.
- The equipment rack where the chassis is to be installed complies with prescribed requirements.
- The following factors have been carefully considered when selecting rack: location, safety, ease of maintenance, and proper airflow.

## Site Selection Guidelines

The device requires specific environmental operating conditions. Temperature, humidity, altitude, and vibration can affect the performance and reliability of the device.

The device is designed to meet the industry EMC, safety, and environmental standards.

## Airflow for Site Planning

*Table 1: Cisco ASR-920-20SZ-M Airflow*

Device	Feature	Maximum System Airflow (CFM) at Maximum System Temperature
ASR-920-20SZ-M	20GE SFP, 4Cu and 4-10GE: Modular power supply	93.0

## Environmental Requirements

Environmental monitoring of the chassis protects the system and components from damage due to excessive voltage and temperature conditions. To ensure normal operation and avoid unnecessary maintenance, plan and prepare your site configuration *before* installation. After installation, ensure that the environmental characteristics continue to be met.

For an outside plant installation (cell site cabinet, hut, and so on), you require to protect the chassis against airborne contaminants, dust, moisture, insects, pests, corrosive gases, polluted air, or other reactive elements. We recommend that you install the unit in a fully sealed enclosure or cabinet. Examples of such cabinets include IP65 cabinets with heat exchanger complying with Telcordia GR487. Temperature must be maintained within  $-40^{\circ}\text{C}$  to  $70^{\circ}\text{C}$ .

Place the device inside a space that is protected from direct weather and environmental stresses by an enclosure.

Ensure the operating climate as defined by Class 2 of GR-3108-CORE for premium variants.

- $-40^{\circ}\text{C}$  ( $-40^{\circ}\text{F}$ ) and  $70^{\circ}\text{C}$  ( $158^{\circ}\text{F}$ )
- 5 and 85% RH

Ensure the operating climate as defined by Class 1 of GR-3108-CORE for base variants.

- $-5^{\circ}\text{C}$  ( $23^{\circ}\text{F}$ ) and  $50^{\circ}\text{C}$  ( $122^{\circ}\text{F}$ )

- < 15 to 85% RH

## Physical Characteristics

To set the device at its proper location, be familiar with its physical characteristics.

## Airflow Guidelines

Cool air is circulated through the chassis by fans that are located along the back of the device.

The internal fans maintain acceptable operating temperatures for the internal components by drawing in cool air through the vents and circulating that air through the chassis.

The direction of airflow is from front-to-back.

To ensure adequate airflow through the equipment rack, we recommend that you always maintain a minimum clearance distance as mentioned in the following specifications.

- Front clearance—5 inches (12.7 centimeters)
- Rear clearance—3.93 inches (10 centimeters)

Note the following points:

- When installing chassis in a back-to-back position with another device, ensure a minimum of 3.93 inches (10 centimeters) airflow clearance between them. Also, ensure that the device behind the chassis is not installed in a way that it blows air into the chassis.
- An over-temperature condition may occur within the rack, if airflow through the rack and the device is restricted, or if the air that is drawn into the rack is warm.
- Ensure that the site is dust free. Dust tends to clog the device fans, reducing the flow of cooling air through the equipment rack and the devices that occupy it, thus increasing the risk of an over-temperature condition.
- Enclosed racks must have adequate ventilation. Because each device generates heat, ensure that the racks are not congested. An enclosed rack must have louvered sides and a fan to provide cool air. Heat that is generated by the equipment near the bottom of the rack may be drawn upward into the intake ports of the equipment above.
- When mounting a chassis on an open rack, ensure that the rack frame does not block the exhaust fans.
- When a rack-installed equipment fails, especially equipment on an enclosed rack, if possible try operating the equipment by itself. Power off all other equipment on the rack (and in adjacent racks) to give the device maximum cooling air and clean power.
- Avoid installing the chassis in a location in which the chassis air intake vents may draw in the exhaust air from an adjacent equipment. Consider how the air flows through the device; the airflow direction is from front to back, with ambient air drawn in from the vents located on the sides of the chassis.



---

**Caution**

When mounting the device on any type of rack equipment, ensure that the temperature of inlet air to the device does not exceed the specified operating temperature limits of the product.

---

## Airflow Guidelines for ETSI Rack Installation

When you install a device on a 2 or 4-post rack, the front and rear doors of the cabinet must be removed. We recommend that you always maintain a minimum clearance distance as mentioned the following.

- Front clearance—5 inches (12.7 centimeters)
- Rear clearance—3.93 inches (10 centimeters)

To mount the chassis in a 4-post enclosed cabinet, ensure a minimum of 3.93 inches (10 centimeters) of clearance on each side of the chassis.

## Floor Loading Considerations

Ensure that the floor under the rack supporting the chassis is able to support the combined weight of the rack and all the other installed equipment.

For additional information about floor loading requirements, see the [GR-63-CORE, Network Equipment Building System \(NEBS\) Requirements: Physical Protection](#) document.

## Site Power Guidelines

The chassis has specific power and electrical wiring requirements. Adhering to these requirements ensures reliable operation of the system. Follow these precautions and recommendations when planning your site power for the chassis:

- The redundant power option provides a second, identical power supply to ensure uninterrupted power supply.
- Connect each power supply to a separate input power source. Otherwise, it results in total power failure to the system due to a fault in the external wiring or a tripped circuit breaker.
- To prevent loss of input power, ensure that the maximum load on each circuit is within the current ratings of the wiring and the breakers.
- Check the power at your site before installation, and periodically after installation, to ensure that you're receiving clean power. If necessary, install a power conditioner.
- Provide proper grounding to avoid personal injury and damage to the equipment due to power surges or lightning striking power lines. The chassis ground must be attached to a central office or other interior ground system.



---

**Note** The chassis installation must comply with all the applicable codes, and is approved for use with only copper conductors. The ground bond-fastening hardware must be compatible and preclude loosening, deterioration, and electrochemical corrosion of hardware and joined material. Attachment of the chassis ground to a central office or other interior ground system must be made with a 6-AWG gauge wire copper ground conductor.

---



---

**Caution** This product requires an external surge protection device for both AC and DC power feeds to the equipment. For a DC power feed, the surge protective device (SPD) must handle common mode and differential mode surge as per the local standards.

---

**Caution**

The AC PSU requires external surge protection devices (SPD) for installations, where an electrical surge is higher than 2KV common mode and higher than 2KV differential mode. Failure to do so may result in permanent damage to the router. Following are the applicable router variants:

- N540-24Z8Q2C-SYS
- N540X-ACC-SYS
- N540-ACC-SYS
- N540X-16Z4G8Q2C-A
- N540X-12Z16G-SYS-A
- N540-28Z4C-SYS-A
- N540X-16Z8Q2C-A
- N540-12Z20G-SYS-A

**Caution**

The DC PSU requires external surge protection devices (SPD) for installations, where an electrical surge is higher than 2KV common mode and higher than 1KV differential mode. Failure to do so may result in permanent damage to the product. Following are the applicable router variants:

- N540-24Z8Q2C-SYS
- N540X-ACC-SYS
- N540-ACC-SYS
- N540X-16Z4G8Q2C-D
- N540X-12Z16G-SYS-D
- N540X-16Z8Q2C-D

Following are the applicable router variants that require external surge protection devices (SPD), where an electrical surge is higher than 1KV common mode and higher than 1KV differential mode:

- N540-12Z20G-SYS-D
- N540-28Z4C-SYS-D

## Electrical Circuit Requirements

Each chassis requires a dedicated electrical circuit. If you equip the device with dual-power feeds, provide a separate circuit for each power supply to avoid compromising the power redundancy feature.

The chassis supports both DC source or an AC source. Ensure that equipment grounding is present and observe power-strip ratings. Make sure that the total ampere rating of all the products plugged into the power strip does not exceed 80% of the rating.

## Site Cabling Guidelines

This section contains guidelines for wiring and cabling at your site. When preparing your site for network connections to the chassis, consider the type of cable that is required for each component and cable limitations. Consider the distance limitations for signaling, electromagnetic interference (EMI), and connector compatibility. Possible cable types are fiber, thick or thin coaxial, foil twisted-pair, or unshielded twisted-pair cabling.

Also, consider any additional interface equipment that you need, such as transceivers, hubs, switches, modems, channel service units (CSU), or data service units (DSU).

Before you install the chassis, have on hand all additional external equipment and cables. For information about ordering, contact a Cisco customer service representative.

The extent of your network and the distances between the network interface connections depend, in part, on the following factors:

- Signal type
- Signal speed
- Transmission medium

The distance and rate limits that are referenced in the following sections are the IEEE-recommended maximum speeds and distances for signaling purposes. Use this information as a guideline when planning your network connections *before* installing the chassis.

If wires exceed the recommended distances, or if wires pass between buildings, give special consideration to the possibility of a lightning strike in your vicinity. The electromagnetic pulse due to lightning or other high-energy phenomena can easily couple enough energy into unshielded conductors to destroy electronic devices. If you have had problems of this sort in the past, you may want to consult experts in electrical surge suppression and shielding.

## Asynchronous Terminal Connections

The chassis provides a console port to connect a terminal or computer for local console access. The port has an RJ-45 connector and supports RS-232 asynchronous data with distance recommendations that are specified in the IEEE RS-232 standard. The available baud rate is 115200 bauds.

## Interference Considerations

When wires are run for any significant distance, there is a risk of receiving stray signals on the wires as interference. If interference signals are strong, it results in data errors or equipment damage.

The following sections describe the sources of interference and how to minimize their effects on the chassis.

### Electromagnetic Interference

All the equipment that is powered by AC current can propagate electrical energy that can cause EMI and possibly affect the operation of other equipment. The typical sources of EMI are equipment power cords and power service cables from electric utilities.

Strong EMI can destroy the signal drivers and receivers in the chassis. It can even create an electrical hazard by causing power surges through the power lines into installed equipment. These problems are rare, but could be catastrophic.

To resolve these problems, you need specialized knowledge and equipment that could consume substantial time and money. However, you can ensure that you have a properly grounded and shielded electrical environment, paying special attention to the need for electrical surge suppression.

## Radio Frequency Interference

When electromagnetic fields act over a long distance, radio frequency interference (RFI) may be propagated. Building wiring can often act as an antenna, receiving the RFI signals and creating more EMI on the wiring.

If you use a twisted-pair cable in your plant wiring with a good distribution of grounding conductors, the plant wiring is unlikely to emit radio interference. If you exceed the recommended distances, use a high-quality twisted-pair cable with one ground conductor for each data signal.

## Lightning and AC Power Fault Interference

If signal wires exceed the recommended cabling distances, or if signal wires pass between buildings, you may encounter a lightning strike on the chassis.

The electromagnetic pulse (EMP) generated by lightning or other high-energy phenomena can couple enough energy into unshielded conductors and damage or destroy electronic equipment. For such problems, you must consult with RFI and EMI experts to ensure adequate electrical surge suppression and shielding of signal cables in your operating environment.



---

**Warning**

This product requires surge protection as part of the building installation. To comply with the Telcordia GR-1089 NEBS standard for electromagnetic compatibility and safety, an external surge protective device (SPD) is required at the AC or DC power service equipment.

---

## Rack-Mounting Guidelines

The following sections provide guidelines for selecting racks and precautions for mounting the chassis on a rack:

### Precautions for Rack-Mounting

Follow these rack-mount guidelines to ensure your safety:

- Ensure that the rack is level and stable before extending a component from the rack.
- Ensure that proper airflow is provided to the components on the rack.
- Do not step on or stand on any component or system when servicing other systems or components on a rack.
- If the rack is provided with stabilizing devices, install the stabilizers before mounting or servicing the chassis.

### Rack Selection Guidelines

Ensure the 2 or 4-post, 19 inches (48.3 centimeters) or 23 inches (58.42 centimeters) rack that you select complies with the Electronic Industries Association (EIA) standard for equipment racks (EIA-310-D). The rack must have at least two posts with mounting flanges to mount the chassis.



---

**Caution**

When mounting a chassis in any type of rack equipment, ensure that the temperature of the inlet air to the chassis does not exceed the specified operating temperature of the chassis.

---

The distance between the center lines of the mounting holes on the two mounting posts must be 18.31 inches (46.50 centimeters)  $\pm$  0.06 inch ( $\pm$  0.15 centimeter). The rack-mounting hardware included with the chassis is suitable for most 19 inches (48.3 centimeters) equipment racks.

Install the chassis on a rack with the following features:

- NEBS-compliant, 19 inches (48.3 centimeters) rack or 23 inches (58.42 centimeters).
- EIA or European Telecommunications Standards Institute (ETSI) hole patterns in the mounting rails. The required mounting hardware is shipped with the chassis. If the rack on which you plan to install the chassis has metric-threaded rails, you must provide your own metric-mounting hardware.
- Perforated top and open bottom for ventilation to prevent overheating.
- Leveling feet for stability.

Do not install the device on an enclosed rack because the chassis requires an unobstructed flow of cooling air to maintain the acceptable operating temperature. If you use an enclosed rack, ensure that the airflow requirements are maintained as discussed in the [Airflow Guidelines](#) section.

## Receive the Device

Each device is shipped in a container that is strapped to a pallet.



Figure 1: The Router Packaged for Shipping

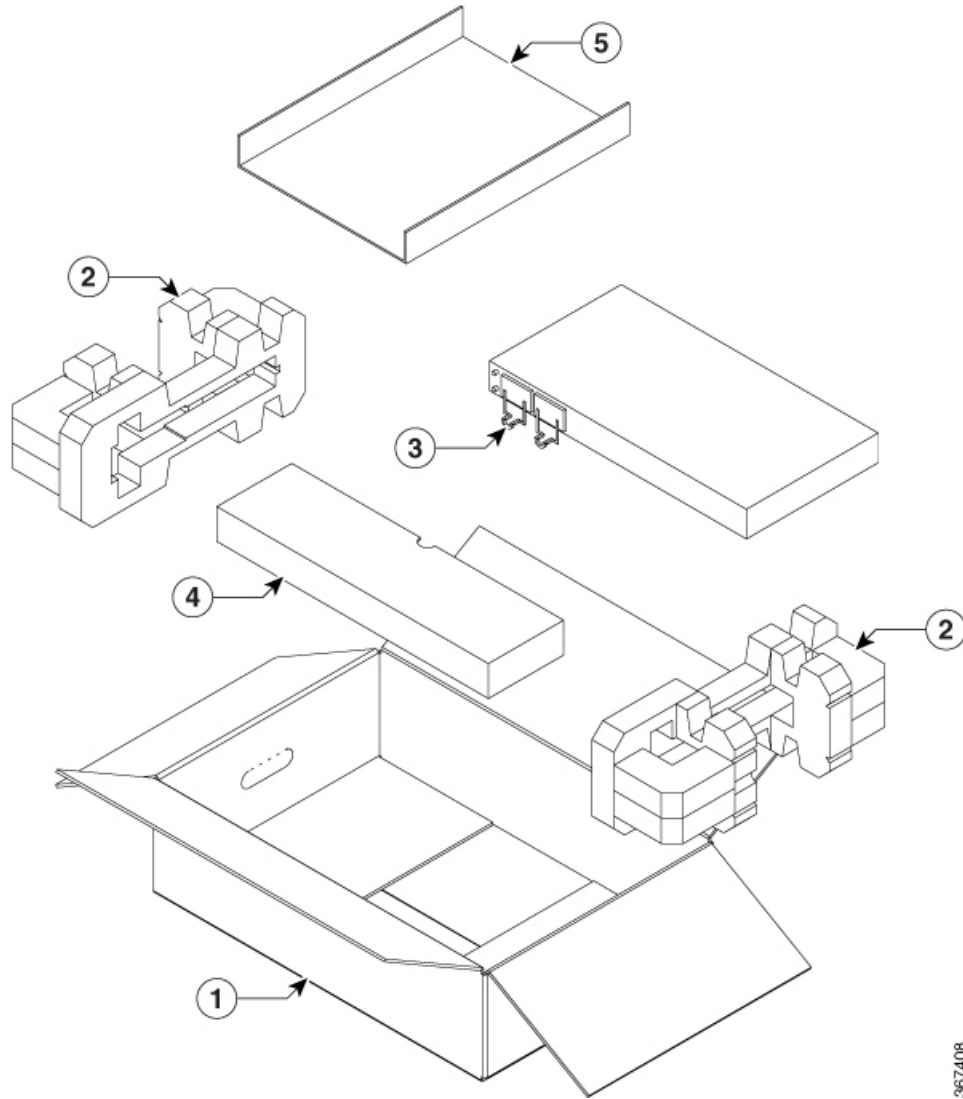

367408

Label	Description	Label	Description
1	Outside carton for accessories	4	Packing carton
2	Assembly packaging material	5	Accessories tray
3	Router	—	—

# Unpack and Verify Shipped Contents

## Procedure

- 
- Step 1** Inspect the shipping container for any shipping damage. If there is obvious physical damage, contact your Cisco service representative, else continue with the remaining steps.
- Step 2** Unpack the device.
- Step 3** Inspect the device.
- Step 4** Use the following table to verify the contents of the container. Do not discard the shipping container. You will need the container in the future if you move or ship the device.
- 

## What to do next

**Table 2: Default Shipping Container Contents**

Component	Description
Device	Cisco ASR-920-20SZ-M
ESD, wrist strap (disposable)	One disposable wrist strap (optional)
Documentation	Cisco ASR 920 Series Router Pointer Card
Optional equipment	<p>Check the container for the following optional equipment:</p> <ul style="list-style-type: none"> <li>• Power cord if an AC power supply is shipped.</li> <li>• Lugs if a DC power supply is shipped.</li> </ul> <p><b>Note</b> If you do not specify the type of power cable, US power cable for the AC device variant is supplied.</p>



---

**Note** Most Cisco documentation is available online. The chassis Pointer Card that is shipped with your Cisco ASR 920 Series Router contains links and information to other online documentation.

---



---

**Note** If the product is not in use, store the device in the initial packaged condition or in an ESD PE sealed bag with silica gel.

---

Table 3: Accessories Kit

Variant	Category	PID	Accessories
ASR-920-20SZ-M	19 inches	A920-RCKMT-19	Yes
	23 inches	A920-RCKMT-23-H	Yes
	ETSI	A920-RCKMT-ETSI	Yes
	Wall mount	A920-RCKMT-19	Yes
	Desktop	NA	No
	Cable bracket	A920-CBL-GUIDE A920-CBL-BRKT-E (ETSI)	Yes
	Dip Tray	A920-DRIP-TRAY	Yes

## Tools and Equipment

You need the following tools and equipment to install and upgrade the device and its components:

- ESD-preventive cord and wrist strap
- Antistatic mat or antistatic foam
- Number 1 and Number 2 Phillips-head screwdrivers
- #12-24 pan-head screws to secure the device to the equipment rack.
- Cables for connecting to network ports (based on the configuration)
- Ethernet hub, switch, or PC with a network interface card for connecting to the Ethernet ports
- Console terminal that is configured for 9600 baud, 8 data bits, no parity, no flow control, and 1 stop bit.
- Console cable for connecting to the console port
- Ratcheting torque screwdriver with a Phillips head that exerts up to 30-pound force per square inch (0.02-kilograms force per square millimeter (kgf/mm<sup>2</sup>)) of pressure.
- Crimping tool as specified by the ground lug manufacturer
- Wire-stripping tools for stripping both 6 and 14-AWG wires
- Tape measure and level
- Ratcheting torque screwdriver with a Phillips head that exerts up to 15 inch-pounds (1.69 newton meters) of torque for attaching the ground wire to the device.

