



Overview



Note The Cisco ASR-920-12SZ-IM and Cisco ASR-920U-12SZ-IM are collectively referred to as the Cisco ASR-920-12SZ-IM Router in this document. Any differences between the routers are specifically called out.

The Cisco ASR 920 Series Aggregation Services Router is a family of fixed configuration routers that provides common network architecture to the Service Providers for macro and small cell networks.

This router acts as an access device for mobile backhaul services—macro Cell Site Router (CSR) and Small Cell Router (SCR). As an access device, it provides capabilities like 1GE/10GE, MPLS, H-QoS, Services, GPS clocking, PoE and fit within ETSI 300 mm depth cabinet. It can easily be integrated into the Unified MPLS for Mobile Transport (UMMT) and Fixed Mobile Convergence (FMC) solution.

- [Cisco ASR 920 Router Features, on page 1](#)
- [Interface Modules, on page 2](#)
- [4-Port OC3/STM-1 \(OC-3\) or 1-port OC12/STM-4 \(OC-12\) Interface Module \(A900-IMA4OS\), on page 8](#)
- [GigabitEthernet Copper Ports, on page 9](#)
- [GE SFP Ports, on page 9](#)
- [SFP+ Ports, on page 10](#)
- [External Interfaces, on page 14](#)

Cisco ASR 920 Router Features

The router provides 1GE/10GE, MPLS, H-QoS, high availability hardware design, advanced Ethernet Operations, Administration, and Maintenance (OAM), as well as advanced timing support, including satellite timing (GNSS) based clocking, and PoE in one platform.

- ASR-920-12SZ-IM—This router has fixed Ethernet interfaces (8x1G copper + 4x1G SFP + 4x10G/1G (dual rate))
- ASR-920-12SZ-IM-CC—Has the same specifications as the above variant. However, this chassis is coated with an acrylic-based material to help improve the reliability against air-borne contamination.

The following table provides snapshot of the number and type of supported ports:

ASR 920 Sub-family	1 GE Port	Dual Rate 1G/10G Port	Type of 1 GE Port
ASR-920-12SZ-IM, ASR-920-12SZ-IM-CC	12	4 ¹ Te0/0/12 – Te 0/0/15	8 Cu ports Ge0/0/0 – Ge0/0/7 4 SFP ports Ge0/0/8 – Ge0/0/11

¹ Each port can operate at either 1G or 10G, and operates in a mutually exclusive way. You cannot insert both 1G and 10G together. If you insert IG IMs (A900-IMA8T1Z, A900-IMA8S1Z, A900-IMA8T, A900-IMA8S), the dual rate port would support only 10G.

Interface Modules

The Cisco ASR-920-12SZ-IM and ASR-920-U-12SZ-IM router interface modules are field-replaceable units. In addition to the ports provided on an RSP, the router supports the following interface modules:

- ASR 900 8 port 10/100/1000 Ethernet Interface Module (A900-IMA8T)
- ASR 900 8 port SFP Gigabit Ethernet Interface Module (A900-IMA8S)
- ASR 900 8 port RJ48C T1/E1 Interface Module (A900-IMA8D)
- ASR 900 16 port T1/E1 Interface Module (requires patch panel) (A900-IMA16D)
- ASR 900 32 port T1/E1 Interface Module (requires patch panel) (A900-IMA32D)
- ASR 900 1 port 10GE XFP Interface Module (A900-IMA1X)
- ASR 900 2 port 10GE SFP+/XFP Interface Module (A900-IMA2Z)
- ASR900 Combo 8 port 10/100/1000 and 1 port 10GE Interface Module (A900-IMA8T1Z)
- ASR900 Combo 8 SFP GE and 1 port 10GE IM (A900-IMA8S1Z)
- ASR 900 4 port OC3/STM1 or 1 port OC12/STM4 Interface Module (A900-IMA4OS)

For more information about supported interface modules, see the [Cisco ASR 903 and ASR 903U Aggregation Services Router Hardware Installation Guide](#) and [Cisco ASR 920 Series Aggregation Services Routers: High-Port-Density Models Data Sheet](#).

8-Port 1 Gigabit Ethernet RJ45 Interface Module (A900-IMA8T)

The 8-port 1 Gigabit Ethernet RJ45 interface module provides eight Gigabit Ethernet copper ports. The figure below shows the interface module.

Figure 1: 8-port 1 GE Gigabit Ethernet RJ45 (Copper) Interface Module

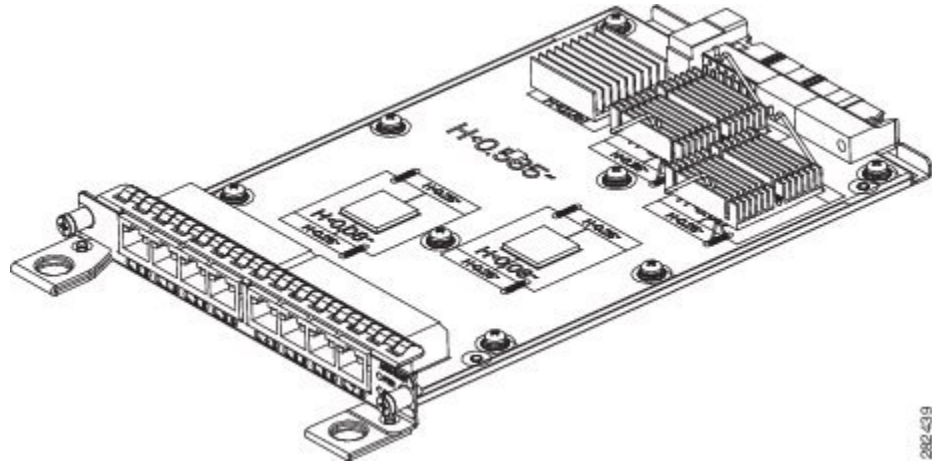

For information on supported SFP modules, see [Cisco ASR 900 Series Aggregation Services Routers Data Sheet](#).

8-Port 1 Gigabit Ethernet SFP Interface Module (A900-IMA8S)

The Gigabit Ethernet Small Form-Factor Pluggable (SFP) interface module provides eight Gigabit Ethernet SFP modules. The figure below shows the 8-port 1 GE Gigabit Ethernet SFP interface module.

Figure 2: 8-port 1 GE Gigabit Ethernet SFP Interface Module

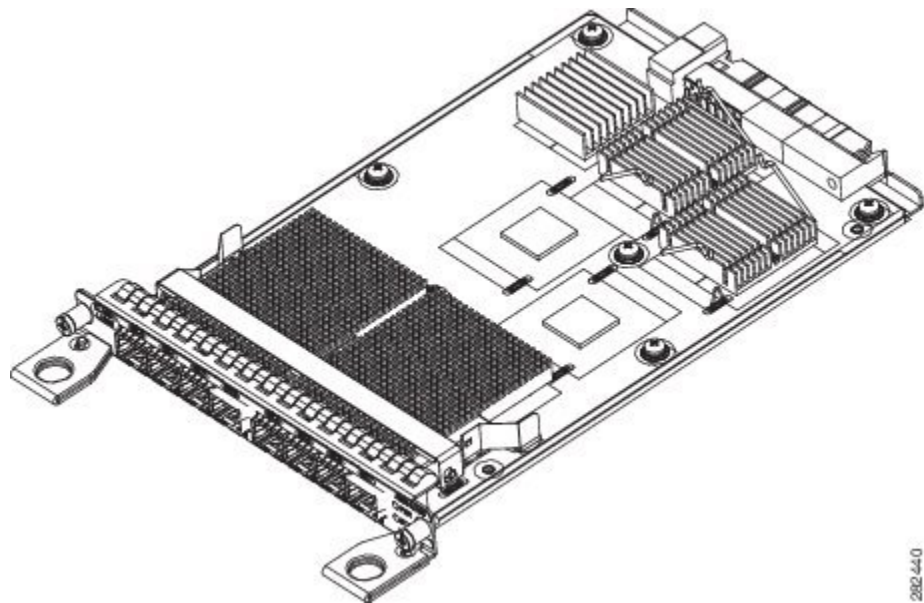

For information on supported SFP modules, see [Cisco ASR 900 Series Aggregation Services Routers Data Sheet](#).

8-port T1/E1 Interface Module (A900-IMA8D)

The 8-port T1/E1 interface module provides connectivity for up to 8 T1/E1 ports through RJ48C port connectors on the front panel. The figure below shows the interface module. For information on supported slots, see *Supported RSPs*.

Figure 3: 8-port T1/E1 Interface Module

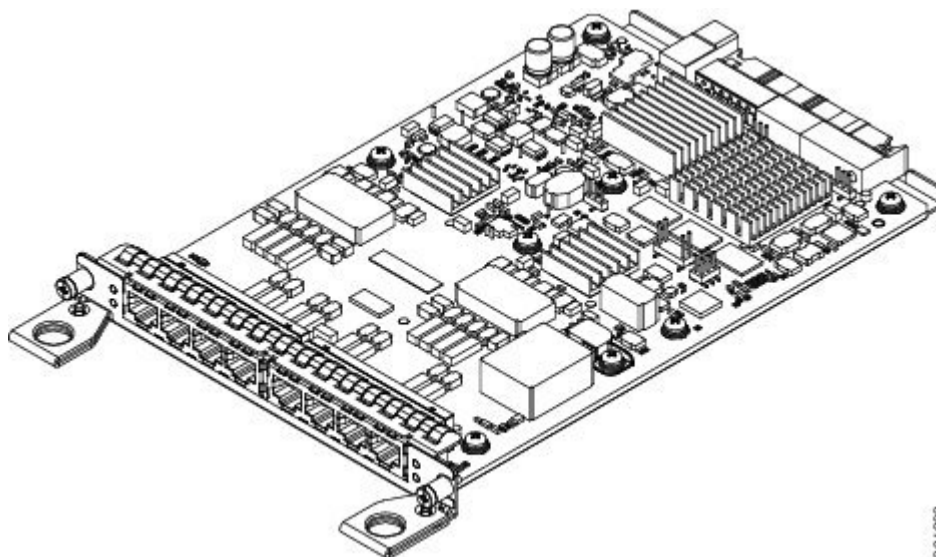

16-Port T1/E1 Interface Module (A900-IMA16D)

The 16-port T1/E1 interface module provides connectivity for up to 16 T1/E1 ports through a 100-pin Amplimite connector. The 16-port T1/E1 interface module requires the use of a patch panel to provide RJ48 (T1) or BNC (E1) connectors. The figure below shows the interface module.

Figure 4: 16-port T1/E1 Interface Module

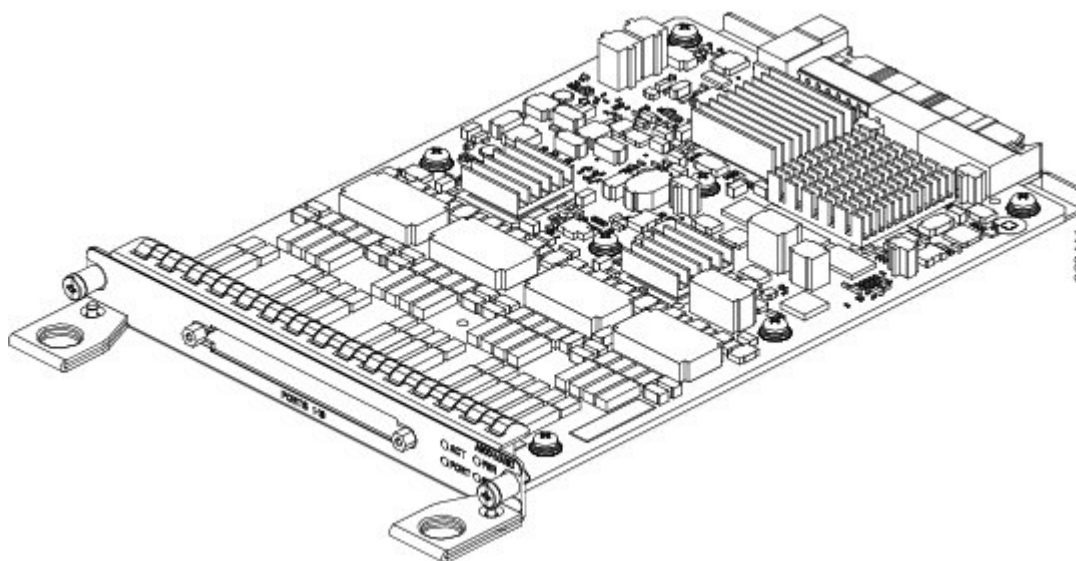

32-Port T1/E1 Interface Module (A900-IMA32D)

The 32-port T1/E1 interface module provides connectivity for up to 32 T1/E1 ports through two 68-pin Tyco connectors. It is supported on the A900-RSP2A-64 module in slots 3, 4 and 5, and on the A900-RSP2A-128 on all slots.

The 32-port T1/E1 interface module requires the use of a patch panel to provide RJ48 or BNC connectors.

Figure 5: 32-port T1/E1 Interface Module

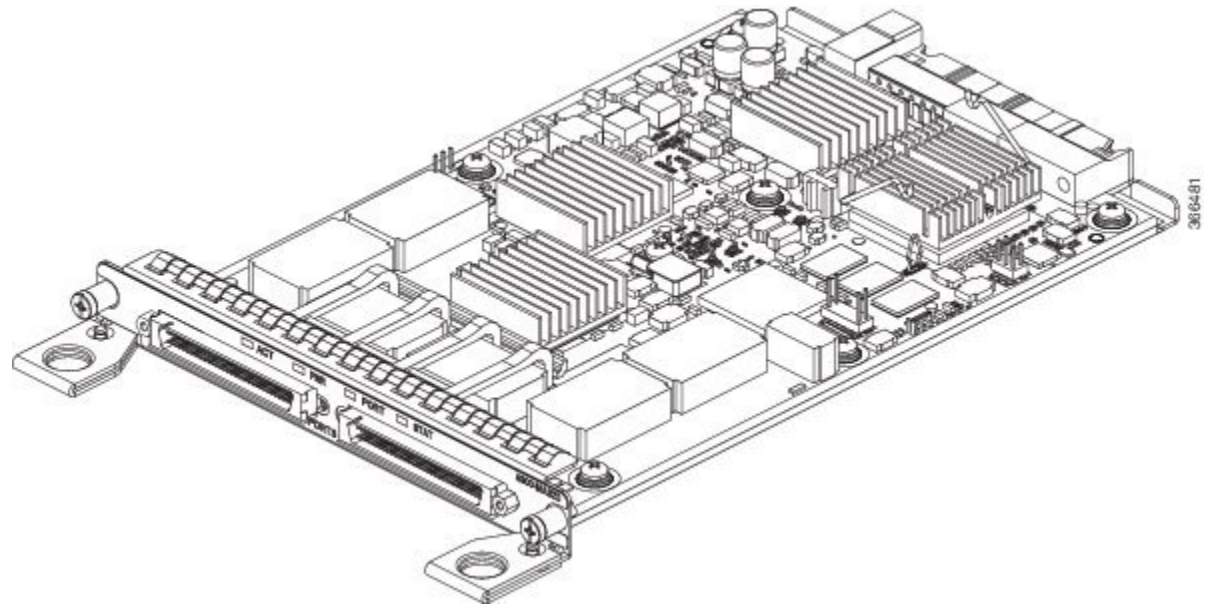

1-Port 10 Gigabit Ethernet XFP Interface Module (A900-IMA1X)

The 10-Port Gigabit Ethernet XFP interface module provides a single port supporting a 10 Gigabit Ethernet XFP module. The figure below shows the interface module.

Figure 6: 1-port 10 Gigabit Ethernet XFP Interface Module

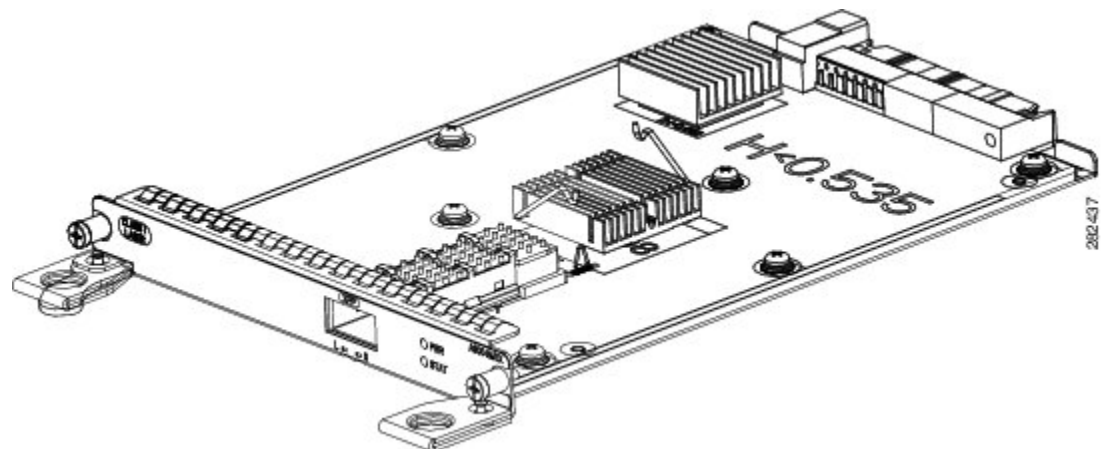



Note 1-port 10 Gigabit Ethernet interface modules are not supported in slots 4 and 5.

For information on supported SFP modules, see [Cisco ASR 900 Series Aggregation Services Routers Data Sheet](#).

2-Port 10 Gigabit Ethernet SFP+ Interface Module (A900-IMA2Z)

The 2-port 10 Gigabit Ethernet interface module provides a dual port supporting a 10 Gigabit Ethernet SFP+ and XFP module.

Figure 7: 2-port 10 Gigabit Ethernet Interface Module

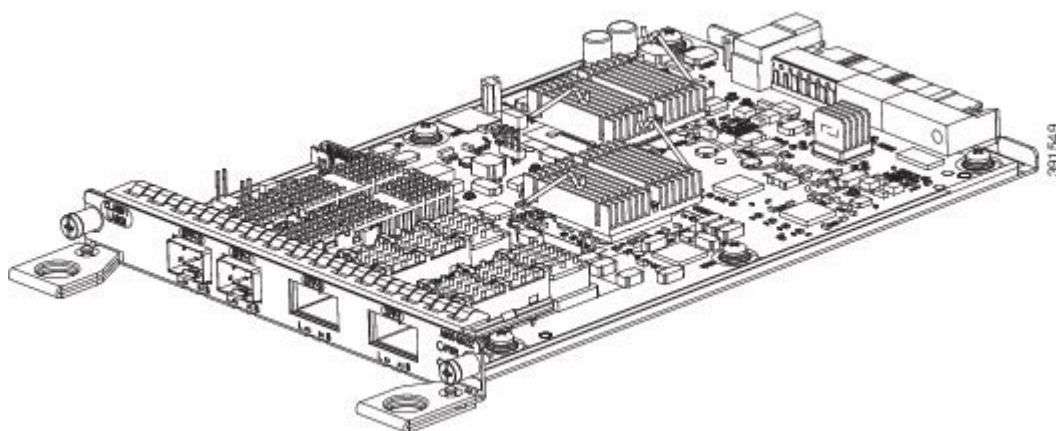

For information on supported SFP modules, see [Cisco ASR 900 Series Aggregation Services Routers Data Sheet](#).

8-Port 1 Gigabit Ethernet + 1-Port 10 Gigabit Ethernet SFP+ Combination Interface Module (A900-IMA8T1Z)

This 8-port 1 Gigabit Ethernet (RJ45 Copper) interface module with the 1-port 10 Gigabit Ethernet interface module is a high density combination interface module. This module supports 8 Gigabit Ethernet Copper ports and 1 10 Gigabit Ethernet SFP+ port.

Figure 8: 8-port 1 GE (RJ45) + 1-port 10 GE SFP+ Interface Module

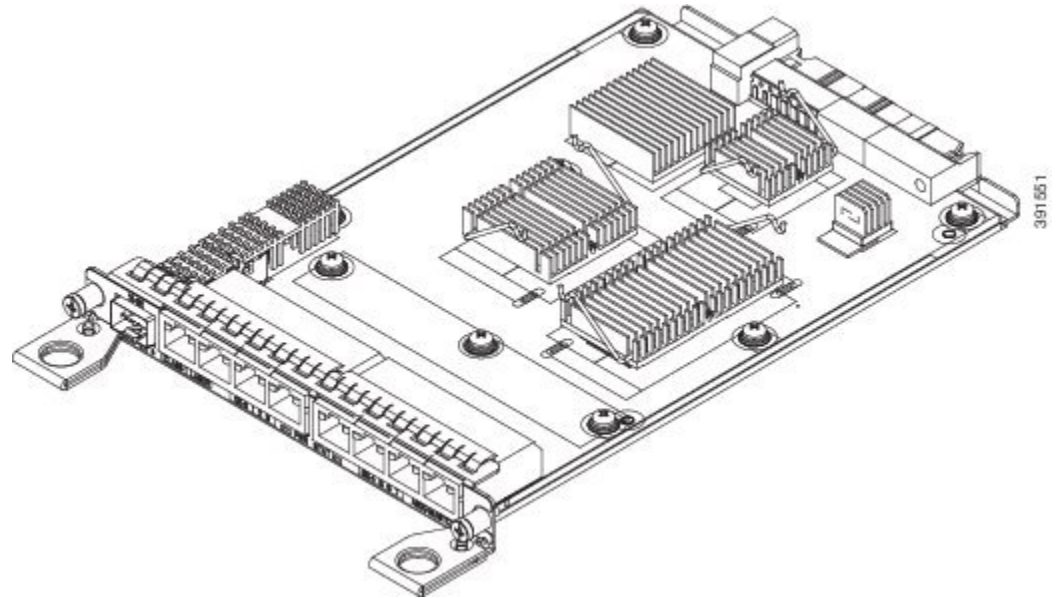

8-Port 1 Gigabit Ethernet SFP with 1-Port 10 Gigabit Ethernet Combination Interface Module (A900-IMA8S1Z)

The 8-port 1 Gigabit Ethernet SFP interface module with the 1-port 10 Gigabit Ethernet interface module is a high density combination interface module. This module supports 8 Gigabit Ethernet SFP ports and 1 10 Gigabit Ethernet SFP+ port.

Figure 9: 8-port 1 GE SFP + 1-port 10 GE SFP+ Interface Module

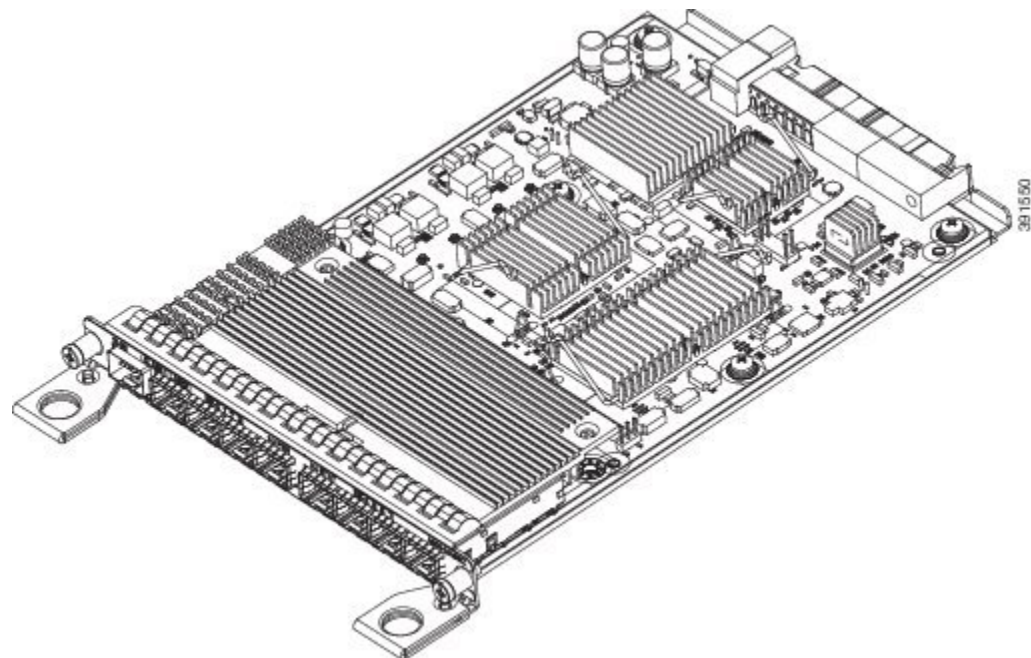

For information on supported SFP modules, see [Cisco ASR 900 Series Aggregation Services Routers Data Sheet](#).

8-Port 1 Gigabit Ethernet SFP with 1-Port 10 Gigabit Ethernet Combination Interface Module (A900-IMA8S1Z)

The 8-port 1 Gigabit Ethernet SFP interface module with the 1-port 10 Gigabit Ethernet interface module is a high density combination interface module. This module supports 8 Gigabit Ethernet SFP ports and 1 10 Gigabit Ethernet SFP+ port.

Figure 10: 8-port 1 GE SFP + 1-port 10 GE SFP+ Interface Module

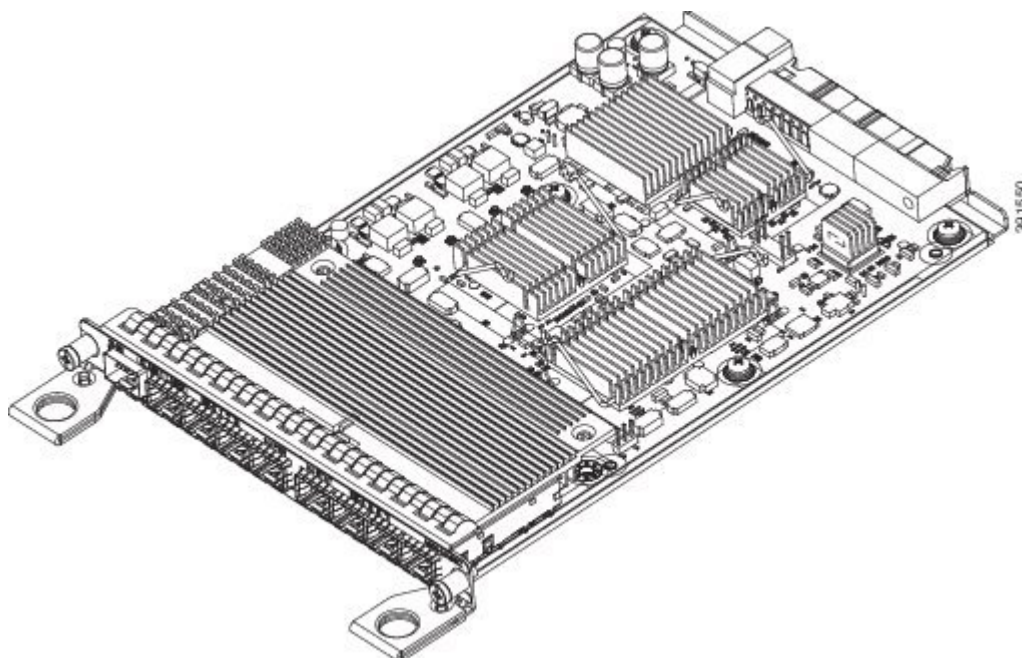

For information on supported SFP modules, see [Cisco ASR 900 Series Aggregation Services Routers Data Sheet](#).

4-Port OC3/STM-1 (OC-3) or 1-port OC12/STM-4 (OC-12) Interface Module (A900-IMA40S)

The 4-port OC3/STM-1 (OC-3) or 1-port OC12/STM-4 (OC-12) interface module can operate as up to four STM-1 interfaces. The figure below shows the interface module.



Note The optical interface module is designed for OC-3 and OC-12 traffic.

Figure 11: 4-port OC-3 Interface Module

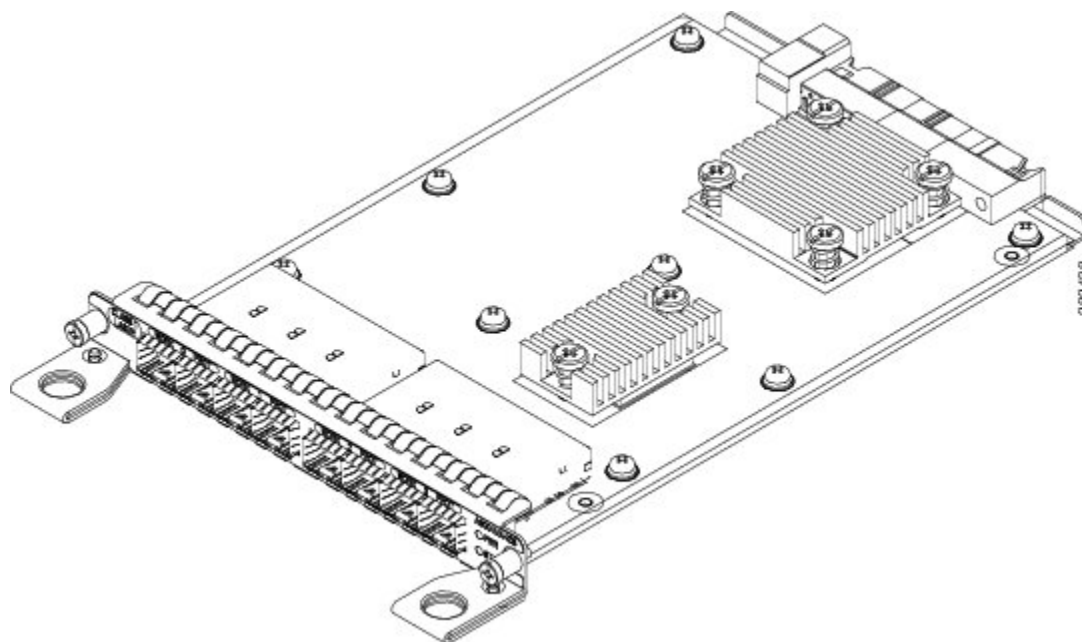

For information on supported SFP modules, see [Cisco ASR 900 Series Aggregation Services Routers Data Sheet](#).

GigabitEthernet Copper Ports

Fixed copper GigabitEthernet (GE) interfaces are provided through standard RJ-45 connectors. These ports support the following features:

- Standard 100/1000Base-T/TX operation with forced or auto-negotiation for speed and duplex.
- Automatic crossover (auto-MDIX) for straight-through and crossover connections.
- Pause flow control as defined by the 802.3x standard.
- Frame size of 9216 bytes.
- Synchronous ENET operation that provides its recovered receive clock as an input clock source for the SETS as well as uses the system-wide reference clock to derive its transmit clock.

GE SFP Ports

The GE SFP ports support the following features:

- 100Base-FX and 1000Base-X SFP modules.
- Digital optical monitoring as specified by the SFP.
- Any mix of SFPs is supported unless specifically noted.
- Pause flow control as defined by the 802.3x standard.
- Frame size of 9216 bytes.
- Synchronous ENET operation that provides its recovered receive clock as an input clock source for the SETS as well as uses the system-wide reference clock to derive its transmit clock.



Note Copper based SFPs do not support synchronous ENET operations.

SFP+ Ports

The SFP+ ports support the following features:

- Digital optical monitoring as specified by the optical transceiver module.
- Any mix of SFPs is supported unless specifically noted.
- Pause flow control as defined by the 802.3x standard.
- Frame size of 9216 bytes.

The following figures show the port numbering for the Cisco ASR 920 router:

Figure 12: Front Panel of Cisco ASR-920-12SZ-IM Router—With DC Power Supply

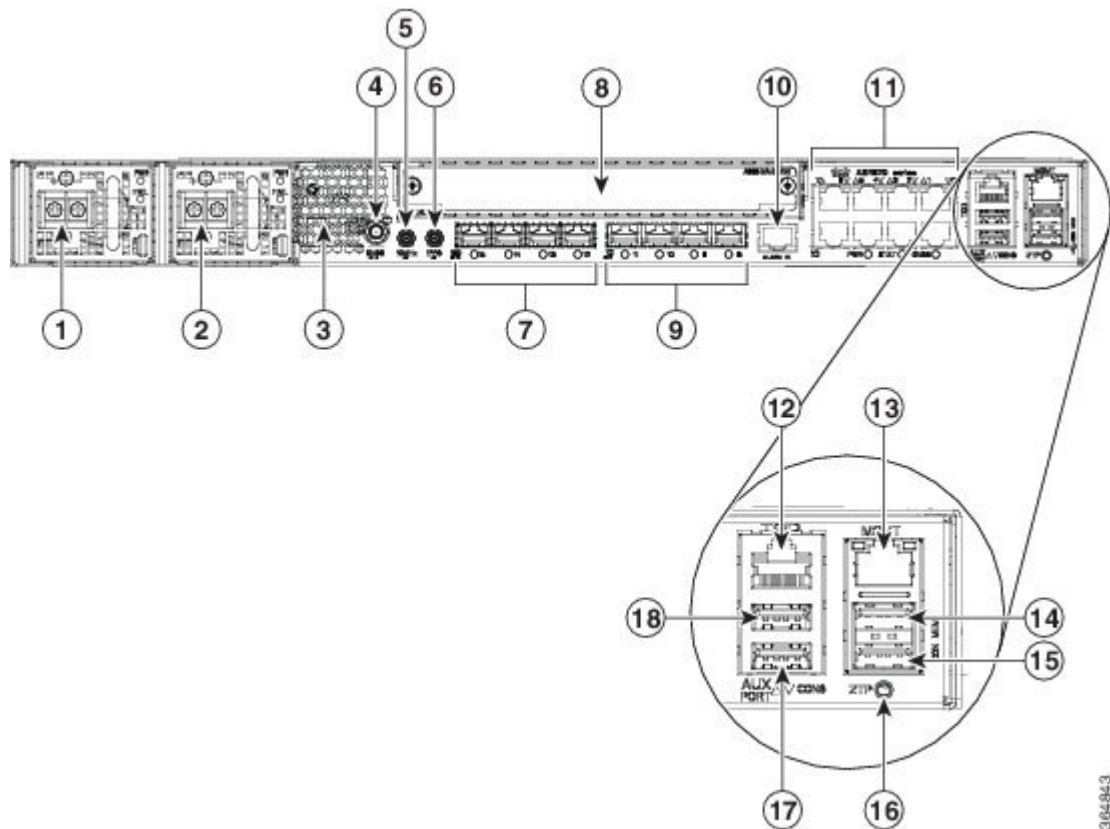

364843

Figure 13: Front Panel of Cisco ASR-920-12SZ-IM Router—With AC Power Supply

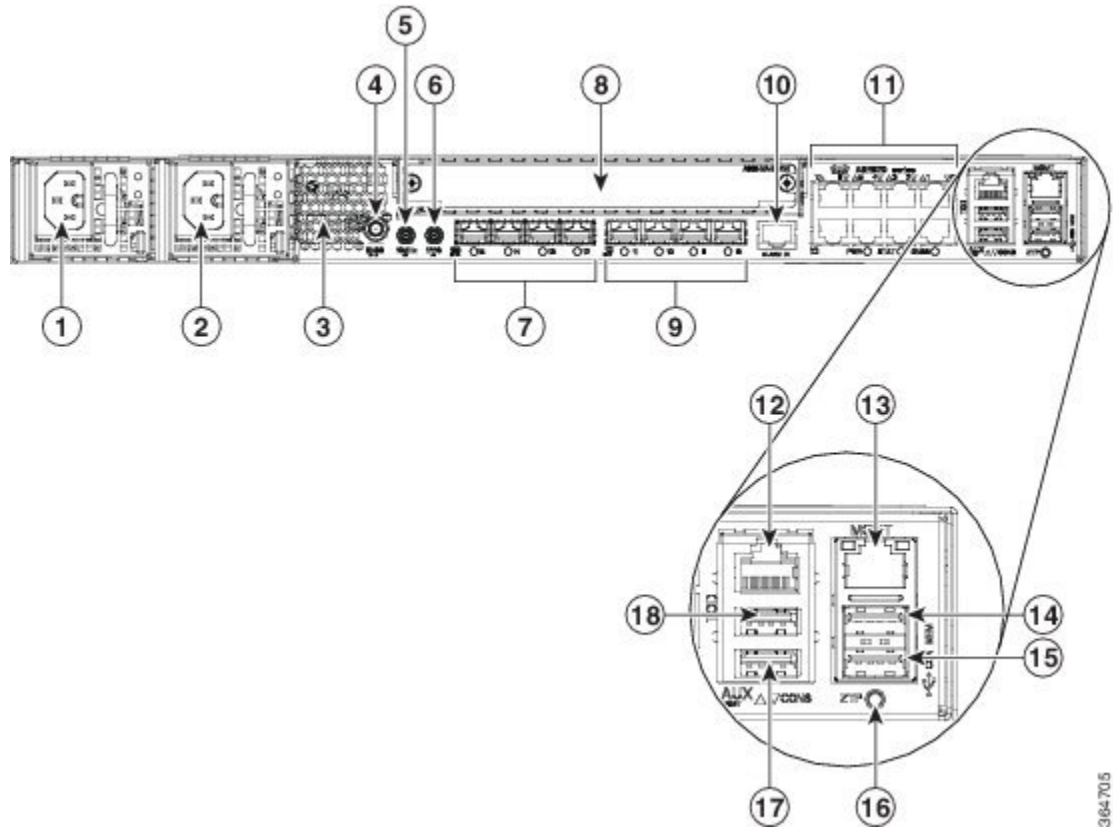

1	Power Supply 0 (AC or DC)	10	Alarm port
2	Power Supply 1 (AC or DC)	11	Eight Copper port (1G PoE) Note Port 0 is located at the bottom right, port 1 is located at the top right, and so on.
3	Front Air-Inlet Area	12	ToD port
4	GNSS RF IN (SMA threaded connector)	13	Management Port
5	DIN 1.0/2.3 Snap-in connector (10MHZ)	14	USB Memory port
6	DIN 1.0/2.3 Snap-in connector (1PPS)	15	USB Console port
7	Four 1G/10G SFP+	16	Zero Touch Provisioning button
8	Interface Module	17	RS232 Console port
9	Four 1G SFP	18	RS232 Aux Console port

3664 705

Figure 14: Rear View of Cisco ASR-920-12SZ-IM Router



1	Fan tray	3	Air vents
2	Grounding lug	—	

The following table describes the other features of Cisco ASR-920-12SZ-IM (AC and DC) Router.

Table 1: Cisco ASR-920-12SZ-IM Router Specifications

Specification	ASR-920-12SZ-IM
Dimension Width x Depth x Height	17.5 x 9.88 x 1.73 inches
Weight	Total weight: 4.83 kg Weight of PSU: 0.59 kg Weight of Fan: 0.33 kg
Rack Unit	One RU
Airflow	Front to back
Cable access	Front cable access
System throughput	60 Gbps, 95 Mpps
Power Supply	
Redundant	Yes
AC	Yes
Voltage Range	85V AC to 264V AC, nominal 100/240 VAC
Frequency Range	47 Hz to 63 Hz, nominal 50/60 Hz
Maximum Power	360 W
DC	Yes
Voltage Range	-18 VDC to -32 VDC or -40 VDC to -72 VDC
Nominal Voltage Range	-24 VDC/-48 VDC/-60 VDC
Maximum Power	375 W
Operating Temperature	-40° C to 70° C

Specification	ASR-920-12SZ-IM
Alarms	<ul style="list-style-type: none"> • 4 alarm dry contact inputs (normally open) • LED indicators for critical, major, and minor alarms
Supported Interface Modules	<p>For more information on these IM modules, see the <i>Cisco ASR 903 Aggregation Series Router Hardware Installation Guide</i>.</p> <p>For more information on the supported IMs, see the <i>Cisco ASR920 Data sheet</i>.</p>
Mounting option	<ul style="list-style-type: none"> • Front or rear rail 19 or 23 inches • ETSI 300 mm open cabinet • Wall mount
Port Configuration	12x1G and 4x10G/1G ports
Port Numbering	<p>4x10G SFP+ – Port [12:15]</p> <p>4x1G SFP – Port [8:11]</p> <p>8x1G PoE RJ45/Cu ports [0:7]</p>
Combo Ports	Ports 12 to 15 are Dual Rate ports
Copper/1G/10G Port LEDs	Link/Activity/Fault
Temperature Sensors	Four temperature sensors
1PPS/ToD	External ports for 1PPS/TOD
PoE	Provides power over Ethernet
GNSS	Connects to the external GPS

Figure 15: Cisco ASR-920-12SZ-IM Router—Dimensions

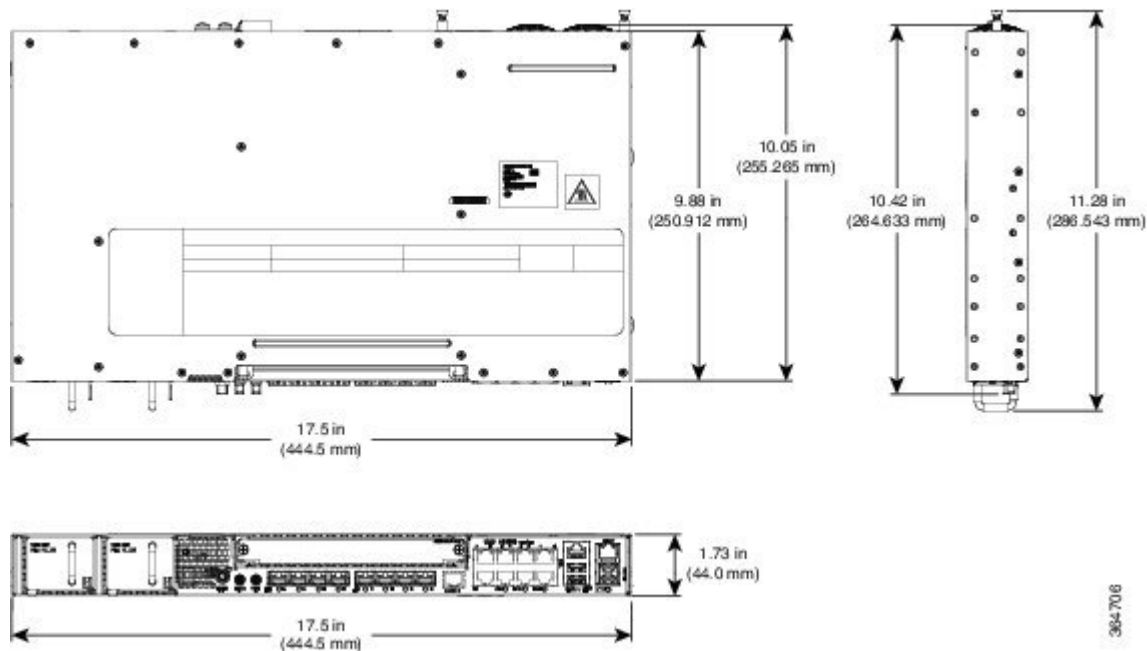

External Interfaces

The external physical interfaces on the front panel of the router are given below:

Network Interfaces

The network interfaces are provided through fixed ports.

- GE SFP ports—supports 100/1000 modes
- GE Copper RJ-45 ports—supports 10/100/1000 operation. All eight copper RJ-45 ports support PoE/PoE+/UPoE with overall power budget of 180 W.



Note PoE is not supported when the system is powered with 24 V DC.

- 10GE SFP+—supports 10G/1G mode depending on the SFP+/SFP in the network interface slot.

Network Timing Interfaces

- 10Mhz input or output—Miniature coaxial connectors for 10Mhz timing (input or output). You can use this interfaces with an external GPS device to send or receive clocking from the router
- 1PPS input or output and ToD input or output—This interface is used for input or output of time-of-day (ToD) and 1PPS pulses. ToD format includes both NTP and IEEE 1588-2008 time formats.

The same RS422 pins for 1PPS and TOD are shared between input and output directions. The direction for each can be independently configured through software.

- GNSS RF IN—This interface is used to connect the external GPS antenna to the in-built GPS module.

External Alarm Inputs

The router supports four dry contact alarm inputs through an RJ-45 jack on the front panel.

- Normally Open—indicates that no current flows through the alarm circuit and the alarm is generated when the current is flowing.

Each alarm input can be provisioned as critical, major, or minor.

Management Interfaces

The following management interfaces are supported:

Management ENET Port

A single management copper ENET port supporting 100/1000Base-T operation is provided on the front panel. It uses a standard RJ-45 jack.

RS232 Console Port

The RS232 console port provides transmission (Tx), reception (Rx), and ground (Gnd).



Note The RS232 console port is enabled only through the Cisco-designed cable adapter USB type A cable to RJ-45 adapter cable. To use this port, disable the flow control on the terminal.



Caution Do not plug the USB-to-RJ45 adapter cable in the USB Memory port.

USB Console

A single USB 2.0 Type-A receptacle on the front panel of the router provides console access to ROMMON, Cisco IOS-XE and diagnostics. While it uses the Type-A connector, it operates as a USB peripheral only for connection to an external host computer. This interface requires the use of a Type-A to Type-A connector instead of a standard USB cable.



Note Use of the USB console is mutually exclusive of the RS232 console port. This interface requires the use of a Type-A to Type-A USB cable.

USB Mass Storage

A single USB 2.0 Type-A receptacle on the front panel of the router allows external USB mass storage devices, such as standard USB flash drives. This interface is used to load images, load or store configurations, write logs, and so on.



Note More than 8 GB is not supported in ROMMON mode,

Zero Touch Provisioning Button

The Zero Touch Provisioning (ZTP) button on the front panel initiates the ZTP process on a short press of less than eight seconds. Pressing the ZTP button for more than eight seconds causes a board reset.

RS232 Auxiliary Console Port

The RS232 Aux console port provides transmission (Tx), reception (Rx), and ground (Gnd).



Note The RS232 Aux console port is enabled only through the Cisco-designed cable adapter from USB type A cable to RJ-45 adapter cable.



Note This is a debug-only port. It is recommended that this port be used by field service engineers only.

Power Supply

The router supports AC, DC, or a combination of both power supplies in a 1+1 redundant configuration. For information on installing the power supplies, see the *Installing the Power Supply* section.



Note If only one PSU is present, a successful firmware upgrade to either primary or secondary microcontroller unit (MCU) triggers a reload of device and is reloaded before any warning messages are displayed.

Table 2: Power Supply Specification

Specification	AC (A920-PWR400-A)	DC (A920-PWR400-D)
Input Voltage	85–264, nominal 100VAC, 240VAC 47–63 Hz, nominal 50/60 Hz	18–32 VD or -40 to -72 VDC Nominal -24V VDC, or -48VDC, or -60VDC
Maximum Input Power	375W (with PoE power of 180W) 150W Max (No PoE)	375W (with PoE power of 180W) 150W Max (No PoE)
Redundant	Yes	Yes

Specification	AC (A920-PWR400-A)	DC (A920-PWR400-D)
How Swap	Yes	Yes
Current sharing	Yes	Yes
Input Connector	IEC60320, C15 style receptacle	Two-position terminal block



Note This product requires surge protection as part of the building installation. To comply with the Telcordia GR-1089 NEBS standard for electromagnetic compatibility and safety, an external surge protective device (SPD) is required at the AC power service equipment.



Note For DC systems, if a surge of more than 500 V is expected, add an appropriate external surge protective device.



Note The routers support AC and DC power supplies in a 1+1 redundant configuration.
One AC and one DC power supply in the same router is also a supported configuration.

The router has a single fan-tray with four fans. The system is designed to operate at its maximum operating temperature of 70° C, in case of failure of a single fan operating temperature of 65° C. The fan tray is field-replaceable.

Table 3: Feature History

Feature Name	Release Information	Description
Switching Fan Speed	Cisco IOS XE Cupertino 17.8.1	This feature enables the Cisco ASR-920-12SZ-IM and Cisco ASR-920-12SZ-IM-CC to switch from default dynamic fan speed to static fan speed in the presence of A900-IMA3G-IMSG interface module. This prevents the interface module from shutting down due to the increase in router's temperature. Also, the switch from dynamic to static fan speed enables the smart SFPs to function efficiently.

The dynamic fan-speed algorithm sets the fan speed based on the ASIC temperature.

Prior to Cisco IOS XE Cupertino Release 17.8.1, by default dynamic fan-speed algorithm for Cisco ASR-920-12SZ-IM and Cisco ASR-920-12SZ-IM-CC was enabled. But, in presence of A900-IMA3G-IMSG interface module, the interface module would shut down due to the increased temperature as the dynamic fan

speed was not sufficient. Also, when the smart SFP was inserted in the node, it would not function with the static fan-speed algorithm mode. This was resulting in the increase of the router's temperature.

Starting with Cisco IOS XE Cupertino Release 17.8.1, in the presence of A900-IMA3G-IMSG interface module, the fan-speed algorithm switches from dynamic to static fan-speed algorithm.

Also, when the smart SFP is inserted, the switch from default dynamic fan-speed algorithm to static fan-speed algorithm helps the smart SFP to function efficiently.

Use the **show platform fan-algorithm** command to verify the fan-speed algorithm configuration for the router:

```
Router#show platform fan-algorithm

Fan Algorithm : Static

Router#
```

Redundancy

The router includes a slot for a redundant power supply. The redundant power supply option provides a second power supply to ensure that power to the chassis continues uninterrupted if one power supply fails or input power on one line fails. Redundancy is supported either with identical power supplies or a combination of AC and DC power supply.

A redundant power supply on the router is recommended. Each power supply should be connected to separate independent power sources to ensure that the router maintains power in the event of a power interruption caused by an electrical failure, a wiring fault, or a tripped circuit breaker.



Note To comply with IEC 61850-3 (voltage interruptions), redundant power supplies with separately derived power feeds are required.

LED Indicators

This section describes the different types of LEDs and their behavior.

PWR and STAT LEDs

The PWR LEDs are available on the front panel. These LEDs provide power on the board (PWR) status. During power up state, these LEDs provide booting status and report errors.



Note The digital code signing functionality validates the integrity and authenticity of the ROMMON image before booting it.

Table 4: PWR and STAT LED Indications

PWR LED State	STAT LED state	Indication	Comment
Amber	Off	Power in the system is all right and FPGA configuration is taking place.	Permanent Amber/Off indicates FPGA configuration failure.
Amber	Red	FPGA Image Validation Error.	System is in unresponsive state.
Flashing Amber and Green alternatively	Amber	Upgrade FPGA image error, continuing with Golden FPGA image.	—
Flashing Amber and Green alternatively	Off	FPGA configuration successful and Digital code signing successfully validated FPGA image. Digital code signing passed the control to Microloader to boot ROMMON.	—
Flashing Amber and Green alternatively	Red	Digital code signing reported failure in ROMMON image validation.	—
Flashing Amber	Flashing Amber	ZTP process has begun. Note A short press of the ZTP button triggers the provisioning. A longer press of more than eight seconds, resets the board.	Both LEDs turn Green once provisioning is complete.
Green	Off	IOS-XE image is booting.	
Green	Green	Successfully booted and system is operating normally.	—
Green	Amber	A minor alarm or synchronization is in Holdover or free-running mode	—
Green	Red	A major or critical alarm (high temperature reported for any sensor) or multiple fan failure.	—

CPU Management Port LEDs

The LED for the 100/1000 Management port is integrated on the connector itself. There are two LEDs in the connector—the LED on the left indicates the Link/Activity status and the LED on the right is non-functional.



Note The CPU management port LED on the right is non-functional and hence doesn't indicate any port status.

Table 5: CPU Management Port LED Indication

LED	LED State	Indication
Left	Green	Link up in 1000 Mbps
	Blinking Green	Activity in 1000 Mbps
	Amber	Link up in 100 Mbps
	Blinking Amber	Activity in 100 Mbps
	Off	Link down

SFP LEDs

Each SFP port has an LED indicator.

Table 6: SFP Port LED Indication

LED	LED State	Indication
Labeled same as the SFP port number	Green	Link up in 1000Base-X/100Base-FX
	Blinking Green	Activity in 1000 Base-X/100Base-FX
	Amber	Fault/Error/Link down
	Off	Administratively down

SFP+ LEDs

Each SFP+ port has an LED indicator.

Table 7: SFP+ Port LED Indication

LED	LED State	Indication
Labeled same as the SFP port number	Green	Link up in 10G/1G
	Blinking Green ²	Activity in 10G/1G
	Amber	Fault/Error/Link down
	Off	Administratively down

² For A900-IMA8T1Z, A900-IMA8S1Z, and A900-IMA2Z LED, status would be Green for Activity in 10G/1G.

RJ-45 LEDs

There is only one LED on each RJ45 port on the fixed slot (slot 0/0) and this indicates only the link or speed status. There is no LED to show the Duplex state. However, there are two LEDs for IM RJ45 ports and they indicate the Link and Duplex state.

Table 8: RJ-45 LED Indication

LED State	Indication
Green	Link up in 10/100/1000Base-T
Blinking Green	Activity in 10/100/1000Base-T
Amber	Fault/Error/Link down
Off	Administratively down

G.703/FXS/FXO Interface Module LEDs

The following table summarizes the LEDs for the G.703/FXS/FXO interface module.

Table 9: Cisco ASR 903 Router G.703/FXS/FXO IM LEDs

LED Label	Color or State	Description
Power (PWR)	Green	All power rails are within spec.
	Red	Disabled
	Off	No Power
Operating Status (STAT)	Red	Failure
	Yellow	Booting
	Green	Operational
	Off	No Power
Port Bi-color LEDs	Green	IM-FPGA Link/In-Frame, working properly
	Solid Yellow	Fault or Loop condition
	Off	Out of Service or not configured (default state)

Power Supply Unit LEDs

Each power supply unit has a corresponding LED on the front panel.

Table 10: PSU LED Indication

Power LED	FAIL LED	Power Supply Condition
Green	Off	Power Supply ON; valid input/output
Yellow 1Hz blinking	Red 1Hz blinking	PSU Warning due to OCP, OTP, UV, OV, OP, abnormal fan operation PSU continues to operate
Off	On	PSU failure due to OCP, OTP, UV, OV, OP, abnormal fan operation. No valid output.
Green 1Hz blinking	Off	Valid power present, shutdown by system.
Yellow	Off	Input voltage low
Off	Off	No valid power input.

System–Interface LED Behavior

Table 11: 1G Copper and 1G SFP LED Indication

Event	1G Copper Port LEDs (Link)	1G SFP Port LEDs
ROMMON	Off	Off
IOS Shut	Off	Off
IOS No shut (cable disconnect)	Amber	Amber
IOS No shut (Link Up)	Green	Green

Table 12: Dual Rate Port LED Indication

Event	Dual Rate (1G/10G) Port LEDs
ROMMON	Off
IOS Shut	Off
IOS No shut (cable disconnect)	Amber
IOS No shut (Link Up)	Green

Table 13: Management Port LED Indication

Event	Management Port LEDs (Link/Duplex)
ROMMON	Green/Off
IOS Shut	Off/Off

Event	Management Port LEDs (Link/Duplex)
IOS No shut (cable disconnect)	Amber/Off
IOS No shut (cable connect)	Green/Green in 1G mode Amber/Green in 100M mode

Fan Tray LEDs

Table 14: Fan Tray LEDs

Color/State	Description
Off	System is not powered on
Green	All fans are working normally
Amber	Single or multiple fan failures and critical error
Red	ROMMON

Online Insertion and Removal

This router supports the following OIR operations:

- When an SFP is removed, there is no effect on traffic flowing on other ports.
- When an SFP is installed, the system initializes that port for operation based upon the current configuration. If the inserted SFP is incompatible with the current configuration for that port, the port does not become operational until the configuration is updated.
- Both power supplies are installed and active and the load may be shared between them or a single PSU could support the whole load. When a power supply is not working or the input cable is removed, the remaining power supply takes the entire load without disruption.
- When a fan tray is removed or replaced, there is no need to power down the router. However, when the fan tray is removed from the router, the router shuts down automatically after some time, depending on the ambient temperature. The time duration before the router shuts down is shown in the table below:

Licensing

The router supports the following types of licenses:

- Port Licensing—Port Upgrade license is available as a "Pay as you Grow" model.
 - 6 ports 1GE upgrade license
 - 2 ports 10G upgrade license
 - Bulk License to enable 12x1port 1GE and 4x10GE ports
- Advanced Metro IP Access
- Metro IP Access

- Metro Access (default)
- Feature licensing

The following methods are used to activate the above licenses:

- Cisco Software Licensing—The Cisco Software License Activation feature is a set of processes and components to activate Cisco software feature sets by obtaining and validating fee-based Cisco software licenses.



Note Licenses generated by the Cisco Software Licensing are tied to the UDI of the chassis and a corresponding watchtower device certificate (WDC) is stored in the system.

- Cisco Smart Licensing—Smart Licensing is usage-based licensing where devices register with the Cisco Secure server.