



# Configuring Circuit Emulation over Packet

This module describes the configuration of Circuit Emulation over Packet (CEoP) shared port adapters (SPAs) on the Cisco ASR 9000 Series Aggregation Services Routers.

## Feature History for Configuring CEoP on Cisco ASR 9000 Series Router

Release	Modification
Release 4.2.0	<ul style="list-style-type: none"><li>• Support for Circuit Emulation Service over Packet Switched Network was added in this SPA:<ul style="list-style-type: none"><li>• Cisco 1-port Channelized OC3/STM-1 SPA (SPA-1CHOC3-CE-ATM)</li></ul></li></ul>
Release 4.3.0	<ul style="list-style-type: none"><li>• Support for Circuit Emulation Service over Packet Switched Network was added in these SPAs:<ul style="list-style-type: none"><li>• Cisco 24-Port Channelized T1/E1 Circuit Emulation and Channelized ATM SPA (SPA-24CHT1-CE-ATM )</li><li>• Cisco 2-Port Channelized T3/E3 Circuit Emulation and Channelized ATM SPA (SPA-2CHT3-CE-ATM)</li></ul></li></ul>

- [Configuring Circuit Emulation over Packet, on page 2](#)
- [Prerequisites for Configuration, on page 2](#)
- [Overview of Circuit Emulation over Packet Service, on page 3](#)
- [Information About Configuring CEoP Channelized SONET/SDH, on page 4](#)
- [Clock Distribution, on page 8](#)
- [How to implement CEM, on page 10](#)
- [Configuration Examples for CEM, on page 35](#)

# Configuring Circuit Emulation over Packet

This module describes the configuration of Circuit Emulation over Packet (CEoP) shared port adapters (SPAs) on the Cisco ASR 9000 Series Aggregation Services Routers.

## Feature History for Configuring CEoP on Cisco ASR 9000 Series Router

Release	Modification
Release 4.2.0	<ul style="list-style-type: none"> <li>• Support for Circuit Emulation Service over Packet Switched Network was added in this SPA:               <ul style="list-style-type: none"> <li>• Cisco 1-port Channelized OC3/STM-1 SPA (SPA-1CHOC3-CE-ATM)</li> </ul> </li> </ul>
Release 4.3.0	<ul style="list-style-type: none"> <li>• Support for Circuit Emulation Service over Packet Switched Network was added in these SPAs:               <ul style="list-style-type: none"> <li>• Cisco 24-Port Channelized T1/E1 Circuit Emulation and Channelized ATM SPA (SPA-24CHT1-CE-ATM )</li> <li>• Cisco 2-Port Channelized T3/E3 Circuit Emulation and Channelized ATM SPA (SPA-2CHT3-CE-ATM)</li> </ul> </li> </ul>

## Prerequisites for Configuration

You must be in a user group associated with a task group that includes the proper task IDs. The command reference guides include the task IDs required for each command. If you suspect user group assignment is preventing you from using a command, contact your AAA administrator for assistance.

Before configuring the Circuit Emulation over Packet (CEoP) service on your router, ensure that these conditions are met:

- You must have one of these SPAs installed in your chassis:
  - Cisco 2-Port Channelized T3/E3 Circuit Emulation and Channelized ATM SPA
  - Cisco 24-Port Channelized T1/E1 Circuit Emulation and Channelized ATM SPA
  - Cisco 1-port Channelized OC3/STM-1 Circuit Emulation and ATM SPA
- You should know how to apply and specify the SONET controller name and *interface-path-id* with the generalized notation *rack/slot/module/port*. The SONET controller name and *interface-path-id* are required with the **controller sonet** command.

- You should know how to apply and specify the T3/E3 and T1/E1 controller name and *interface-path-id* with the generalized notation *rack/slot/module/port*. The T3/E3, T1/E1 controller name and *interface-path-id* are required with the **controller {T3|E3|T1|E1}** command.

## Overview of Circuit Emulation over Packet Service

Circuit Emulation over Packet (CEoP) is a way to carry TDM circuits over packet switched network. Circuit Emulation over Packet is an imitation of a physical connection. The goal of CEoP is to replace leased lines and legacy TDM networks. This feature allows network administrators to use their existing IP or MPLS network to provide leased-line emulation services or to carry data streams or protocols that do not meet the format requirements of other multiservice platform interfaces. CEoP puts TDM bits into packets, encapsulates them into an appropriate header and then sends that through PSN. The receiver side of CEoP restores the TDM bit stream from packets.

CEoP SPAs are half-height (HH) Shared Port Adapters (SPA) and the CEoP SPA family consists of 24xT1/E1/J1, 2xT3/E3, and 1xOC3/STM1 unstructured and structured (NxDS0) quarter rate, half height SPAs. The CEoP SPAs provide bit-transparent data transport that is completely protocol independent.

CEoP has two major modes:

- Unstructured mode is called SAToP (Structure Agnostic TDM over Packet) — SAToP does not look what is inside the incoming data and considers it as a pure bit stream.
- Structured mode is named CESoPSN (Circuit Emulation Service over Packet Switched Network) — CESoPSN is aware of the structure of the incoming TDM bit stream at DS0 level.

CESoPSN and SAToP can use MPLS, UDP/IP, and L2TPv3 for the underlying transport mechanism.



**Note** The Cisco IOS XR Release 4.2.x supports only MPLS transport mechanism.

These SPAs are the first Cisco router interfaces designed to meet the emerging standards for Circuit Emulation Services over Packet Switched Network (CESoPSN) and Structure-Agnostic Transport over Packet (SAToP) transport.

In SAToP mode, these SPAs do not assume that data has any predefined format or structure. They simply regard the data as an arbitrary bit stream. All data bits are simply transported to a defined destination encapsulated in IP/MPLS packets. In CESoPSN mode the carrier has defined format. The SPAs support a full range of E1 and T1 framing. CESoPSN applications can save utilized bandwidth by selecting only valid timeslots for transmission. Some primary applications include:

- Transporting 2G and 3G network traffic over packet networks, for mobile operators. Mobile service providers are implementing high-speed data networks with HSDPA to support new revenue-generating services. The SPA is uniquely positioned for multigenerational migration of mobile networks (2G and 3G), simultaneously carrying TDM and ATM traffic over IP/MPLS networks. This technology provides a mechanism to enable IP/MPLS to the cell site, which can eventually be in place to transport the mobile traffic over IP from end to end.
- T3/E3 circuit emulation for leased-line replacement.
- T1/E1 circuit emulation for leased-line replacement.

- PBX to PBX connectivity over PSN.
- High density SS7 backhaul over IP/MPLS.
- Inter-MSC connectivity.
- Preencrypted data for government, defense, or other high-security applications.
- Proprietary synchronous or asynchronous data protocols used in transportation, utilities, and other industries.
- Leased-line emulation service offerings in metropolitan (metro) Ethernet or WAN service provider environments.

For more information on Circuit Emulation service concepts, configuration, and example, see the *Implementing Point to Point Layer 2 Services* module in the *Cisco ASR 9000 Series Aggregation Services Router L2VPN and Ethernet Services Configuration Guide*.

## Information About Configuring CEoP Channelized SONET/SDH

To configure the Circuit Emulation over Packet Channelized SONET/SDH, you must understand the following concepts:

### Channelized SONET and SDH Overview

Synchronous Optical Network (SONET) is an American National Standards Institute (ANSI) specification format used in transporting digital telecommunications services over optical fiber.

Channelized SONET provides the ability to transport SONET frames across multiplexed T3/E3 and virtual tributary group (VTG) channels.

SONET uses Synchronous Transport Signal (STS) framing. An STS is the electrical equivalent to an optical carrier 1 (OC-1).

A channelized SONET interface is a composite of STS streams, which are maintained as independent frames with unique payload pointers. The frames are multiplexed before transmission.

When a line is channelized, it is logically divided into smaller bandwidth channels called *paths*. These paths carry the SONET payload. The sum of the bandwidth on all paths cannot exceed the line bandwidth.

When a line is not channelized, it is called *clear channel*, and the full bandwidth of the line is dedicated to a single channel that carries broadband services.

The T3/E3 channels can be channelized into T1s, and the T1s can be channelized further into DS0 time slots.

Channelizing a SONET line consists of two primary processes:

- Configuring the controller
- Configuring the interface into channelized paths

You configure the controller first by setting the mode of the STS path.

When the mode is specified, the respective controller is created, and the remainder of the configuration is applied on that controller. For example, mode T3 creates a T3 controller. The T3 controller can then be

configured to a serial channel, or it can be further channelized to carry T1s, and those T1s can be configured to serial interfaces.

Depending on the support for your installed SPA, each STS path can be independently configured into T3s, E3s, or VTGs, and so on.

The following level of SONET channelization modes are supported in CEoP SPA:

OC3->STS-1->VTG-> VT1.5 -> Unframed T1

OC3->STS-1->VTG-> VT1.5 -> T1 -> DS0

This figure shows the VTG paths that can be configured.



**Note** Only VTG paths are supported on the Cisco 1-Port Channelized OC-3/STM-1 SPA on the Cisco ASR 9000 Series Router.

**Figure 1: SONET VTG Channelized Paths**

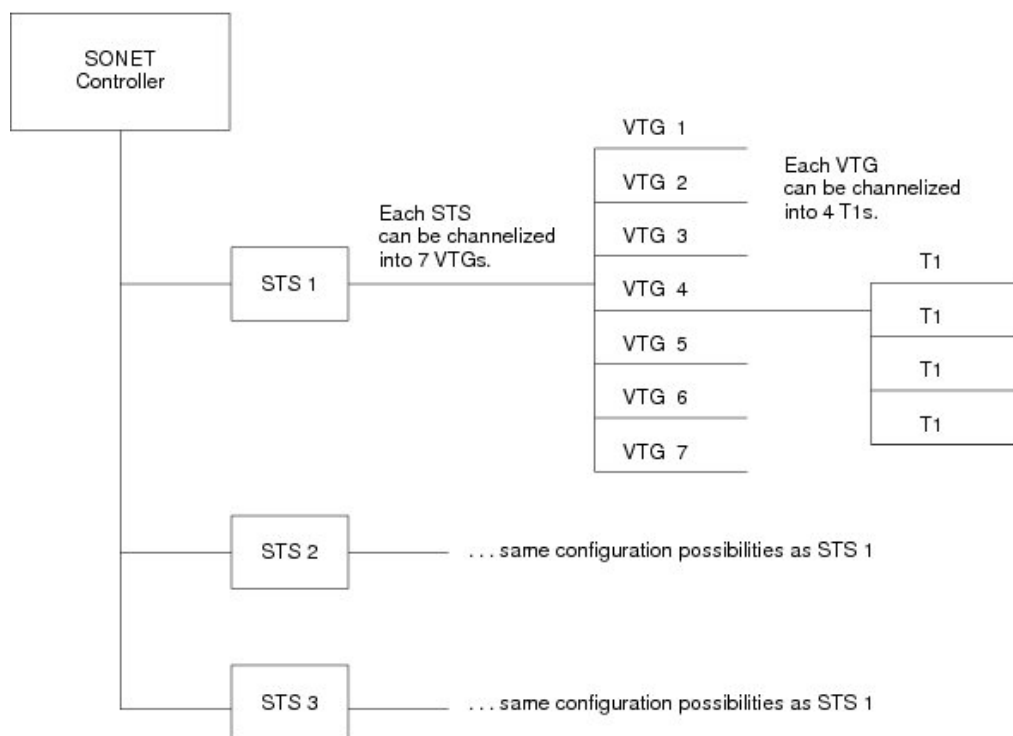

210877

Synchronous Digital Hierarchy (SDH) is the international equivalent of SONET.

SDH uses Synchronous Transport Mode (STM) framing. An STM-1 is the electrical equivalent to 3 optical carrier 1s (OC-1s). A Synchronous Transport Module (STM) signal is the Synchronous Digital Hierarchy (SDH) equivalent of the SONET STS, but the numbers are different for each bandwidth. In this guide, the STM term refers to both path widths and optical line rates. The paths within an STM signals are called administrative units (AUs).

A summary of the basic terminology differences between SONET and SDH is as follows:

- SONET STS is equivalent to SDH administrative unit (AU)

- SONET VT is equivalent to SDH tributary unit (TU)
- SDH basic building blocks are STM-1 (equivalent to STS-3) and STM-0 (equivalent to STS-1)

An administrative unit (AU) is the information structure that provides adaptation between the higher-order path layer and the multiplex section layer. It consists of an information payload (the higher-order virtual container) and an administrative unit pointer, which indicates the offset of the payload frame start relative to the multiplex section frame start.

An AU can be channelized into tributary units (TUs) and tributary unit groups (TUGs).

An administrative unit 3 (AU-3) consists of one STM-1.

An administrative unit group (AUG) consists of one or more administrative units occupying fixed, defined positions in an STM payload.

This table shows the commonly used notations and terms in SONET standards and their SDH equivalents.

**Table 1: SONET and SDH Terminology Equivalencies**

SONET Term	SDH Term
SONET	SDH
STS-3c	AU-4
STS-1	AU-3
VT	TU
SPE	VC
Section	Regenerator Section
Line	Multiplex Section
Path	Path

The following levels of SDH channelization are supported on the CEoP SPA:

- For E1 :
  - STM1-> AU-4 -> TUG-3 -> TUG-2 ->VC12-> Unframed E1
  - STM1-> AU-4 -> TUG-3 -> TUG-2 ->VC12-> E1 -> DS0
- For T1 :
  - STM1-> AU-3-> TUG-2 -> VC11->Unframed T1
  - STM1-> AU-3-> TUG-2 -> VC11->T1 -> DS0

This figure shows an example of SDH AU-3 paths that can be configured on the CEoP SPA.

Figure 2: SDH AU3 Paths

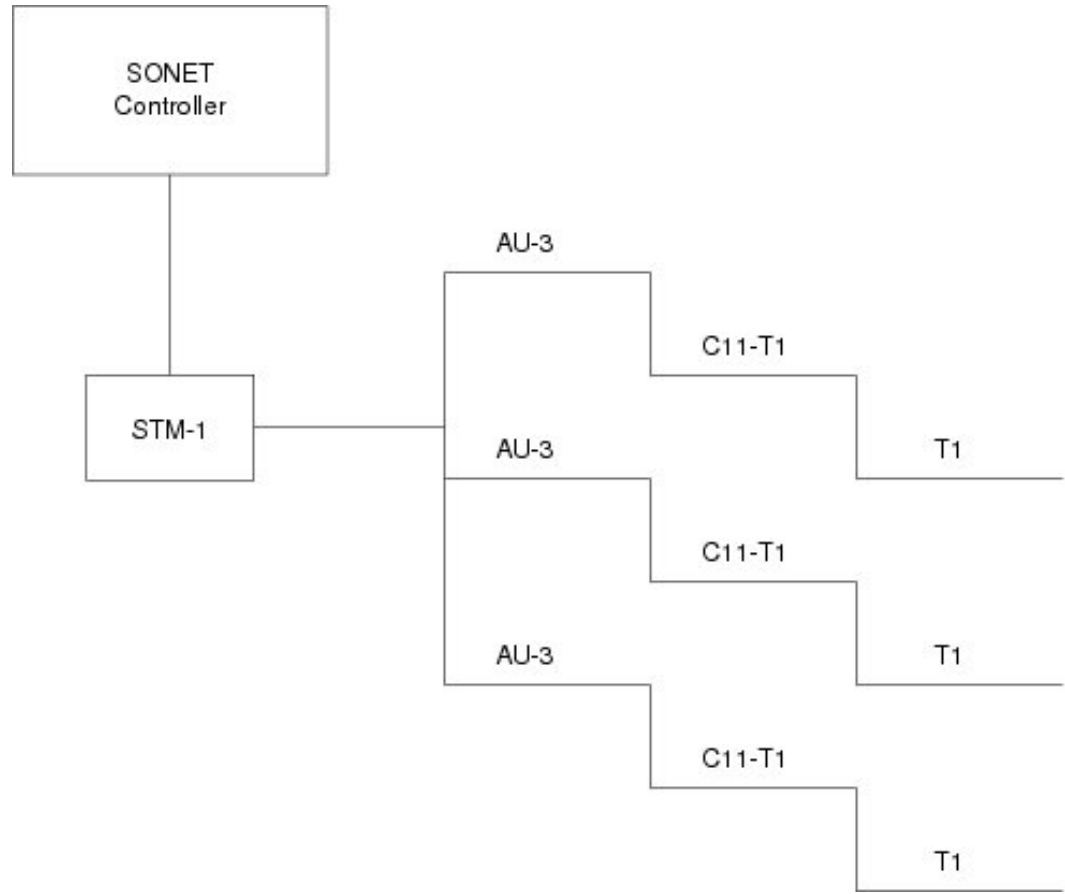

This figure shows the SDH AU4 paths that can be configured on the CEoP SPA.

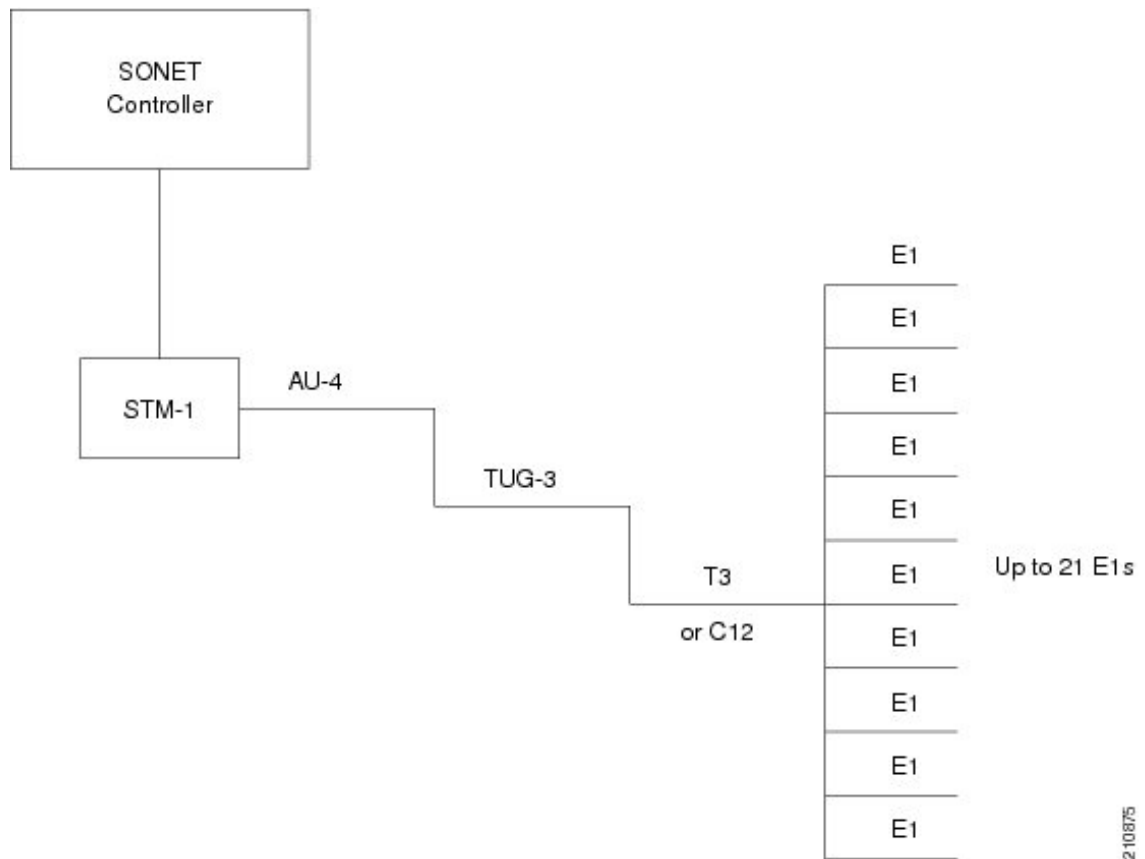

## Default Configuration Values for Channelized SONET/SDH

This Table describes the default configuration parameters that are present on the Channelized SONET/SDH.

*Table 2: SONET/SDH Controller Default Configuration Values*

Parameter	Default Value	Configuration File Entry
Clock source	line	<b>clock source</b> {internal   line}
SONET framing	sonet	<b>hw-module sub-slot node-id cardtype</b> {sonet   sdh}

## Clock Distribution

Clocking distribution in the CEoP SPA can be done in these ways:

- Synchronous Clocking — With synchronous clocking, TDM lines on source and destination are synchronized to the same clock delivered by some means of physical clock distribution (SONET/SDH, BITS, GPS, and so on). The clock to the particular TDM line can be delivered from
  - Line: the transmit clock is from the receiver of the same physical line



- Internal: the transmit clock is taken from line card and can be derived either from an internal free running oscillator or from another physical line
- Recovered: In-band pseudowire-based activeclock recovery on a CEM interface which is used to drive the transmit clock.

The number of recovered clocks that can be configured for CEoP SPA are:

- Cisco 24-Port Channelized T1/E1 Circuit Emulation and Channelized ATM SPA : 24 clocks for each SPA.
- Cisco 2-Port Channelized T3/E3 Circuit Emulation and Channelized ATM SPA : 10 clocks for each SPA in the T1/E1 mode and 2 clocks for each SPA in the T3/E3 mode.
- Cisco 1-port Channelized OC3/STM-1 Circuit Emulation and Channelized ATM SPA : 10 clocks per SPA in the T1/E1 mode.
- Adaptive Clocking — Adaptive clocking is used when the routers do not have a common clock source. See this figure. The clock is derived based on packet arrival rates. Two major types of adaptive clock recovery algorithms are:
  - Based on dejitter buffer fill level
  - Based on packet arrival rate

The clock quality depends on packet size, has less tolerance to packet loss/corruption and introduces unnecessary delay in order to have sufficient number of packets in the buffer for clock recovery. The dejitter buffer size determines the ability of the emulated circuit to tolerate network jitter. The dejitter buffer in CEoP software is configurable up to a maximum of 500 milliseconds.



---

**Note** The CEoP SPA hardware supports only the packet arrival rate algorithm.

---

**Figure 3: Adaptive Clock Recovery**

- Differential clocking — Differential clocking is used when the cell site and aggregation routers have a common clock source but TDM lines are clocked by a different source. The TDM clocks are derived from differential information in the RTP header of the packet with respect to the common clock. Differential clock recovery is based on time stamps received in RTP header. On the reference clock side, the difference of TDM clock and network clock is recorded into RTP header. On the subordinate clock side, these timestamps are read from RTP header, the clock recovery is done and this clock is used for synchronization. See [Figure 5](#).



---

**Note** The Cisco 1-port Channelized OC3/STM-1 CEoP SPA hardware can recover only a maximum of ten unique clocks in as many CEM interfaces. The CEM interfaces where clock recovery is configured must be on unique T1s.

---

For information on CEM configuration and commands, see *Implementing Point to Point Layer 2 Services module* in the *Cisco ASR 9000 Series Aggregation Services Router L2VPN and Ethernet Services Configuration*

*Guide and Cisco ASR 9000 Series Aggregation Services Router L2VPN and Ethernet Services Command Reference.*

For a sample CEM interface configuration, refer [Circuit Emulation Interface Configuration: Examples](#).

## How to implement CEM

This section contains the following procedures:

### Configuring SONET VT1.5-Mapped T1 Channels and Creating CEM Interface

In the case of Cisco 1-port Channelized OC3/STM-1 CEoP SPA, the STS stream can be channelized into the VT1.5 mapped T1 channel.

This task explains how to configure a SONET line into VT-mapped T1 Channels.

#### Before you begin

None.

#### Restrictions

Channelized SONET STS stream with VT1.5-T1 mapping is supported on the following SPA:

- Cisco 1-Port Channelized OC-3/STM-1 SPA

#### SUMMARY STEPS

1. **configure**
2. **hw-module subslot** *node-id* **cardtype** {sonet| sdh}
3. **commit**
4. **controller sonet** *interface-path-id*
5. **sts** *number*
6. **mode** *mode*
7. **root**
8. **controller t1** *interface-path-id*
9. **cem-group unframed**
10. **controller t1** *interface-path-id*
11. **cem-group framed** *group-number* **timeslots** *range1-range2*
12. **no shutdown**
13. **end** or **commit**
14. **show runn interface cem** *interface-path-id*

#### DETAILED STEPS

	Command or Action	Purpose
Step 1	<b>configure</b> <b>Example:</b>	Enters global configuration mode.

	Command or Action	Purpose
	RP/0/RSP0/CPU0:router# configure	
<b>Step 2</b>	<p><b>hw-module subslot <i>node-id</i> cardtype {sonet sdh}</b></p> <p><b>Example:</b></p> <pre>RP/0/RSP0/CPU0:router(config-sonet)# hw-module subslot 0/3/0 sonet</pre>	<p>Configures the controller for SONET framing.</p> <p>SONET framing (<b>sonet</b>) is the default. Whenever there is a change in framing mode (sonet/sdh), the SPA will be reloaded automatically. Reload will happen only when all the CEM Interface, T1 Controller and Sonet Controller configurations are removed completely. This is not applicable when you configure the first time because T1 controller and interface configurations would not exist.</p> <p>This configuration is mandatory for CEoP SPA to work normally in one of the framing modes. When you configure for the first time, it will not cause a SPA reload, if the cardtype is set to Sonet.</p>
<b>Step 3</b>	<b>commit</b>	Use the <b>commit</b> command to save the configuration changes to the running configuration file and remain within the configuration session.
<b>Step 4</b>	<b>controller sonet <i>interface-path-id</i></b>	Enters controller configuration submode and specifies the SONET controller name and instance identifier with the <i>rack/slot/module/port/controllerName</i> notation.
<b>Step 5</b>	<p><b>sts <i>number</i></b></p> <p><b>Example:</b></p> <pre>RP/0/RSP0/CPU0:router(config-sonet)# sts 1</pre>	Configures the STS stream specified by <i>number</i> . The range is from 1 to 3.
<b>Step 6</b>	<p><b>mode <i>mode</i></b></p> <p><b>Example:</b></p> <pre>RP/0/RSP0/CPU0:router(config-stsPath)# mode t1</pre>	<p>Sets the mode of interface at the STS level. The possible modes are:</p> <ul style="list-style-type: none"> <li>• vt15-t1—SONET path carrying virtual tributary 1.5 T1s (VT15 T1)</li> </ul>
<b>Step 7</b>	<p><b>root</b></p> <p><b>Example:</b></p> <pre>RP/0/RSP0/CPU0:router(config-stsPath)# root</pre>	Exits to global configuration mode. Go to step 7, if you want to create an structure agnostic CEM interface. Go to step 9, if you want to create a structure aware CEM interface.
<b>Step 8</b>	<p><b>controller t1 <i>interface-path-id</i></b></p> <p><b>Example:</b></p> <pre>RP/0/RSP0/CPU0:router(config)# controller t1 0/0/1/0/1/4/1</pre>	Enters T1 controller configuration submode and specifies the T1 controller name and <i>interface-path-id</i> with the <i>rack/slot/module/port/sts-num/vtg-num/T1-num</i> notation.
<b>Step 9</b>	<p><b>cem-group unframed</b></p> <p><b>Example:</b></p>	Creates an structure agnostic CEM interface.

	Command or Action	Purpose
	RP/0/RSP0/CPU0:router(config)# cem-group unframed	
<b>Step 10</b>	<b>controller t1</b> <i>interface-path-id</i> <b>Example:</b> RP/0/RSP0/CPU0:router(config)# controller t1 0/0/1/0/1/5/1	Enters T1 controller configuration submode and specifies the T1 controller name and <i>interface-path-id</i> with the <i>rack/slot/module/port/sts-num/vtg-num/T1-num</i> notation.
<b>Step 11</b>	<b>cem-group framed</b> <i>group-number</i> <b>timeslots</b> <i>range1-range2</i> <b>Example:</b> RP/0/RSP0/CPU0:router(config)# cem-group framed 0 timeslots 1	Creates an structure aware CEM interface. The <b>timeslots</b> keyword specifies the time slots for the interface by range with the <i>range1-range2</i> notation.
<b>Step 12</b>	<b>no shutdown</b> <b>Example:</b> RP/0/RSP0/CPU0:router(config-if)# no shutdown	Removes the shutdown configuration. <b>Note</b> <ul style="list-style-type: none"> <li>Removal of the shutdown configuration eliminates the forced administrative down on the interface, enabling it to move to an up or down state (assuming that the parent SONET layer is not configured administratively down).</li> </ul>
<b>Step 13</b>	<b>end</b> or <b>commit</b> <b>Example:</b> RP/0/RSP0/CPU0:router(config-sonet)# end or RP/0/RSP0/CPU0:router(config-sonet)# commit	Saves configuration changes. <ul style="list-style-type: none"> <li>When you issue the <b>end</b> command, the system prompts you to commit changes:   <pre>Uncommitted changes found, commit them before   exiting (yes/no/cancel)? [cancel]:</pre> </li> <li>Entering <b>yes</b> saves configuration changes to the running configuration file, exits the configuration session, and returns the router to EXEC mode.</li> <li>Entering <b>no</b> exits the configuration session and returns the router to EXEC mode without committing the configuration changes.</li> <li>Entering <b>cancel</b> leaves the router in the current configuration session without exiting or committing the configuration changes.</li> <li>Use the <b>commit</b> command to save the configuration changes to the running configuration file and remain within the configuration session.</li> </ul>

	Command or Action	Purpose
Step 14	<b>show runn interface cem</b> <i>interface-path-id</i> <b>Example:</b> RP/0/RSP0/CPU0:router# show runn interface cem 0/0/2/0/1/1/1/1:1	Verifies the CEM interface configuration.

## Configuring SDH AU-3 Mapped to C11-T1 or C12-E1

This section includes the following tasks:

### Configuring SDH AU-3 Mapped to C11-T1 and Creating CEM Interface

This task explains how to configure SDH AU-3 with c11-t1 mapping.

#### Before you begin

- You should know how to configure the SONET/SDH controller.

#### Restrictions

Channelized SDH AU-3 with c11-t1 mapping is supported on this SPA:

- Cisco 1-Port Channelized OC-3/STM-1 SPA

#### SUMMARY STEPS

- configure**
- hw-module sub-slot** *node-id* **cardtype** *type*
- commit**
- controller sonet** *interface-path-id*
- au** *number*
- mode** *mode*
- root**
- controller t1** *interface-path-id*
- cem-group unframed**
- controller t1** *interface-path-id*
- cem-group framed** *group-number* **timeslots** *range1-range2*
- no shutdown**
- end** or **commit**
- show runn interface cem** *interface-path-id*

#### DETAILED STEPS

	Command or Action	Purpose
Step 1	<b>configure</b> <b>Example:</b>	Enters global configuration mode.

	Command or Action	Purpose
	RP/0/RSP0/CPU0:router# configure	
<b>Step 2</b>	<p><b>hw-module sub-slot <i>node-id</i> cardtype <i>type</i></b></p> <p><b>Example:</b></p> <pre>RP/0/RSP0/CPU0:router(config-sonet)# hw-module sub-slot &lt;&gt; cardtype sdh</pre>	<p>Configures the controller for Synchronous Digital Hierarchy (SDH) framing. The <b>hw-module subslot <i>node-id</i> cardtype <i>type</i></b> command configures the SPA to function in sonet/sdh mode.</p> <p>This command when committed results in automatic reload of SPA. Reload happens only when all the CEM interface, T1 Controller and Sonet Controller configurations are removed completely. This is not applicable when you configure the first time because T1 controller and interface configurations would not exist.</p> <p>This configuration is mandatory for CEoP SPA to work normally in one of the framing modes. SONET framing (<b>sonet</b>) is the default.</p>
<b>Step 3</b>	<b>commit</b>	Use the <b>commit</b> command to save the configuration changes to the running configuration file and remain within the configuration session.
<b>Step 4</b>	<b>controller sonet <i>interface-path-id</i></b>	Enters controller configuration submode and specifies the SDH controller name and instance identifier with the <i>rack/slot/module/port/controllerName</i> notation.
<b>Step 5</b>	<p><b>au <i>number</i></b></p> <p><b>Example:</b></p> <pre>RP/0/RSP0/CPU0:router(config-sonet)# au 1</pre>	<p>Specifies the administrative unit (AU) group and enters AU path configuration mode. For AU-3, the valid range is:</p> <ul style="list-style-type: none"> <li>• 1 to 3—1-Port Channelized OC-3/STM-1 SPA</li> </ul> <p><b>Note</b></p> <ul style="list-style-type: none"> <li>• The <b>au</b> command does not specify the AU type. It specifies the number of the AU group for the AU type that you want to configure. The range for the AU command varies based on whether you are configuring AU-3 or AU-4.</li> </ul>
<b>Step 6</b>	<p><b>mode <i>mode</i></b></p> <p><b>Example:</b></p> <pre>RP/0/RSP0/CPU0:router(config-auPath)# mode c11-t1</pre>	Sets the mode of interface at the AU level. AU-3 paths can be mapped to c11-t1 on supported SPAs.
<b>Step 7</b>	<p><b>root</b></p> <p><b>Example:</b></p> <pre>RP/0/RSP0/CPU0:router(config-auPath)# root</pre>	Exits to global configuration mode.

	Command or Action	Purpose
Step 8	<p><b>controller t1</b> <i>interface-path-id</i></p> <p><b>Example:</b></p> <pre>RP/0/RSP0/CPU0:router(config)# controller T1 0/0/2/0/1/1/4</pre>	Enters T1 controller configuration submode and specifies the T1 controller name and <i>interface-path-id</i> with the <i>rack/slot/module/port/auNum/t1Num</i> notation.
Step 9	<p><b>cem-group unframed</b></p> <p><b>Example:</b></p> <pre>RP/0/RSP0/CPU0:router(config)# cem-group unframed</pre>	Creates a structure agnostic CEM interface.
Step 10	<p><b>controller t1</b> <i>interface-path-id</i></p> <p><b>Example:</b></p> <pre>RP/0/RSP0/CPU0:router(config)# controller t1 0/0/2/0/1/1/7</pre>	Enters T1 controller configuration submode and specifies the T1 controller name and <i>interface-path-id</i> with the <i>rack/slot/module/port/auNum/t1Num</i> notation.
Step 11	<p><b>cem-group framed</b> <i>group-number</i> <i>timeslots</i> <i>range1-range2</i></p> <p><b>Example:</b></p> <pre>RP/0/RSP0/CPU0:router(config)# cem-group framed 1 timeslots 2-3</pre>	Creates a structure aware CEM interface. The <b>timeslots</b> keyword specifies the time slots for the interface by range with the <i>range1-range2</i> notation.
Step 12	<p><b>no shutdown</b></p> <p><b>Example:</b></p> <pre>RP/0/RSP0/CPU0:router(config-if)# no shutdown</pre>	<p>Removes the shutdown configuration.</p> <p><b>Note</b></p> <ul style="list-style-type: none"> <li>Removal of the shutdown configuration eliminates the forced administrative down on the interface, enabling it to move to an up or down state (assuming that the parent SONET layer is not configured administratively down).</li> </ul>
Step 13	<p><b>end</b> or <b>commit</b></p> <p><b>Example:</b></p> <pre>RP/0/RSP0/CPU0:router(config-sonet)# end</pre> <p>or</p> <pre>RP/0/RSP0/CPU0:router(config-sonet)# commit</pre>	<p>Saves configuration changes.</p> <ul style="list-style-type: none"> <li>When you issue the <b>end</b> command, the system prompts you to commit changes: <pre>Uncommitted changes found, commit them before   exiting (yes/no/cancel)? [cancel]:</pre> </li> <li>Entering <b>yes</b> saves configuration changes to the running configuration file, exits the configuration session, and returns the router to EXEC mode.</li> <li>Entering <b>no</b> exits the configuration session and returns the router to EXEC mode without committing the configuration changes.</li> </ul>

	Command or Action	Purpose
		<ul style="list-style-type: none"> <li>Entering <b>cancel</b> leaves the router in the current configuration session without exiting or committing the configuration changes.</li> <li>Use the <b>commit</b> command to save the configuration changes to the running configuration file and remain within the configuration session.</li> </ul>
<b>Step 14</b>	<b>show runn interface cem <i>interface-path-id</i></b> <b>Example:</b>  RP/0/RSP0/CPU0:router# show runn interface cem 0/0/2/0/1/1/1/1:1	Verifies the CEM interface configuration.

## Configuring SDH AU-3 Mapped to C12-E1 and Creating CEM Interface

This task explains how to configure SDH AU-3 with c12-e1 mapping.

### Before you begin

- You should know how to configure the SONET/SDH controller.

### Restrictions

Channelized SDH AU-3 with c12-e1 mapping is supported on this SPA:

- Cisco 1-Port Channelized OC-3/STM-1 SPA

### SUMMARY STEPS

- configure**
- hw-module sub-slot *node-id* cardtype *type***
- commit**
- controller sonet *interface-path-id***
- au *number***
- mode tug3**
- width *number***
- tug3 *number***
- mode *mode***
- root**
- controller e1 *interface-path-id***
- cem-group unframed**
- controller e1 *interface-path-id***
- cem-group framed *group-number* timeslots *range1-range2***
- no shutdown**
- end** or **commit**



## DETAILED STEPS

	Command or Action	Purpose
Step 1	<p><b>configure</b></p> <p><b>Example:</b></p> <pre>RP/0/RSP0/CPU0:router# configure</pre>	Enters global configuration mode.
Step 2	<p><b>hw-module sub-slot <i>node-id</i> cardtype <i>type</i></b></p> <p><b>Example:</b></p> <pre>RP/0/RSP0/CPU0:router(config-sonet)# hw-module sub-slot &lt;&gt; cardtype sdh</pre>	Configures the controller framing for Synchronous Digital Hierarchy (SDH) framing. The <b>hw-module subslot <i>node-id</i> cardtype <i>type</i></b> command configures the SPA to function in sonet/sdh mode. This command when committed results in automatic reload of SPA. Reload happens only when all the CEM interface, E1 Controller and Sonet Controller configurations are removed completely.
Step 3	<p><b>commit</b></p>	Use the <b>commit</b> command to save the configuration changes to the running configuration file and remain within the configuration session.
Step 4	<p><b>controller sonet <i>interface-path-id</i></b></p>	Enters controller configuration submode and specifies the SDH controller name and instance identifier with the <i>rack/slot/module/port/controllerName</i> notation.
Step 5	<p><b>au <i>number</i></b></p> <p><b>Example:</b></p> <pre>RP/0/RSP0/CPU0:router(config-sonet)# au 1</pre>	<p>Specifies the administrative unit (AU) group and enters AU path configuration mode. For AU-3, the valid range is:</p> <ul style="list-style-type: none"> <li>• 1 to 3—1-Port Channelized OC-3/STM-1 SPA</li> </ul> <p><b>Note</b></p> <ul style="list-style-type: none"> <li>• The <b>au</b> command does not specify the AU type. It specifies the number of the AU group for the AU type that you want to configure. The range for the AU command varies based on whether you are configuring AU-3 or AU-4.</li> </ul>
Step 6	<p><b>mode tug3</b></p> <p><b>Example:</b></p> <pre>RP/0/RSP0/CPU0:router(config-auPath)# mode tug3</pre>	Sets the mode of interface at the AU level. Currently only TUG3 is supported.
Step 7	<p><b>width <i>number</i></b></p> <p><b>Example:</b></p> <pre>RP/0/RSP0/CPU0:router(config-auPath)# width 3</pre>	Configures the number of the AU streams.
Step 8	<p><b>tug3 <i>number</i></b></p> <p><b>Example:</b></p>	Specifies the Tributary Unit Group (TUG) <i>number</i> and enters the config-tug3Path mode. The range is 1 to 3.

	Command or Action	Purpose
	<pre>RP/0/RSP0/CPU0:router(config-auPath)#tug3 1</pre>	
<b>Step 9</b>	<p><b>mode</b> <i>mode</i></p> <p><b>Example:</b></p> <pre>RP/0/RSP0/CPU0:router(config-tug3Path)# mode c12-e1</pre>	<p>Sets the mode of interface at the tug3 level. The modes are:</p> <ul style="list-style-type: none"> <li>• <b>c12-e1</b>—TUG-3 path carrying TU-12 to E1</li> </ul>
<b>Step 10</b>	<p><b>root</b></p> <p><b>Example:</b></p> <pre>RP/0/RSP0/CPU0:router(config-auPath)# root</pre>	Exits to global configuration mode.
<b>Step 11</b>	<p><b>controller e1</b> <i>interface-path-id</i></p> <p><b>Example:</b></p> <pre>RP/0/RSP0/CPU0:router(config)# controller E1 0/0/2/0/1/1/1</pre>	Enters E1 controller configuration submode and specifies the E1 controller name and <i>interface-path-id</i> with the <i>rack/slot/module/port/auNum/tugNum/t1Num</i> notation.
<b>Step 12</b>	<p><b>cem-group unframed</b></p> <p><b>Example:</b></p> <pre>RP/0/RSP0/CPU0:router(config)# cem-group unframed</pre>	Creates an structure agnostic CEM interface.
<b>Step 13</b>	<p><b>controller e1</b> <i>interface-path-id</i></p> <p><b>Example:</b></p> <pre>RP/0/RSP0/CPU0:router(config)# controller E1 0/0/2/0/1/1/7</pre>	Enters E1 controller configuration submode and specifies the E1 controller name and <i>interface-path-id</i> with the <i>rack/slot/module/port/auNum/tugNum/t1Num</i> notation.
<b>Step 14</b>	<p><b>cem-group framed</b> <i>group-number timeslots range1-range2</i></p> <p><b>Example:</b></p> <pre>RP/0/RSP0/CPU0:router(config)# cem-group framed 0 timeslots 1</pre>	Creates an structure aware CEM interface.
<b>Step 15</b>	<p><b>no shutdown</b></p> <p><b>Example:</b></p> <pre>RP/0/RSP0/CPU0:router(config-if)# no shutdown</pre>	<p>Removes the shutdown configuration.</p> <p><b>Note</b></p> <ul style="list-style-type: none"> <li>• Removal of the shutdown configuration eliminates the forced administrative down on the interface, enabling it to move to an up or down state (assuming that the parent SONET layer is not configured administratively down).</li> </ul>
<b>Step 16</b>	<p><b>end</b> or <b>commit</b></p>	Saves configuration changes.

	Command or Action	Purpose
	<p><b>Example:</b></p> <pre>RP/0/RSP0/CPU0:router(config-sonet)# end</pre> <p>or</p> <pre>RP/0/RSP0/CPU0:router(config-sonet)# commit</pre>	<ul style="list-style-type: none"> <li>• When you issue the <b>end</b> command, the system prompts you to commit changes:  Uncommitted changes found, commit them before exiting (yes/no/cancel)? [cancel]:</li> <li>• Entering <b>yes</b> saves configuration changes to the running configuration file, exits the configuration session, and returns the router to EXEC mode.</li> <li>• Entering <b>no</b> exits the configuration session and returns the router to EXEC mode without committing the configuration changes.</li> <li>• Entering <b>cancel</b> leaves the router in the current configuration session without exiting or committing the configuration changes.</li> <li>• Use the <b>commit</b> command to save the configuration changes to the running configuration file and remain within the configuration session.</li> </ul>

## Configuring the Cisco 24-Port Channelized T1/E1 Circuit Emulation and Channelized ATM SPA and Creating CEM Interface

This task explains how to configure the Cisco 24-Port Channelized T1/E1 Circuit Emulation and Channelized ATM SPA.

### SUMMARY STEPS

1. **configure**
2. **hw-module subslot *node-id* cardtype {t1| e1}**
3. **controller t1|e1 *interface-path-id***
4. **cem-group unframed**
5. **controller t1|e1 *interface-path-id***
6. **cem-group framed *group-number* timeslots *range1-range2***
7. **no shutdown**
8. **end** or **commit**
9. **show runn interface cem *interface-path-id***

### DETAILED STEPS

	Command or Action	Purpose
Step 1	<p><b>configure</b></p> <p><b>Example:</b></p>	Enters global configuration mode.

	Command or Action	Purpose
	RP/0/RSP0/CPU0:router# configure	
<b>Step 2</b>	<b>hw-module subslot <i>node-id</i> cardtype {t1 e1}</b> <b>Example:</b> RP/0/RSP0/CPU0:router(config-t1)# hw-module subslot 0/3/0 cardtype t1	The <b>hw-module subslot <i>node-id</i> cardtype <i>type</i></b> command configures the SPA to function in t1/e1 mode.  Reload will happen only when all the CEM interface, T1 Controller configurations are removed completely. This is not applicable when you configure the first time because T1 controller and interface configurations would not exist.
<b>Step 3</b>	<b>controller t1 e1 <i>interface-path-id</i></b> <b>Example:</b> RP/0/RSP0/CPU0:router(config)# controller t1 0/0/1/0/1	Enters T1 controller configuration submode and specifies the T1 controller name and <i>interface-path-id</i> with the <i>rack/slot/module/port/T1num</i> notation.
<b>Step 4</b>	<b>cem-group unframed</b> <b>Example:</b> RP/0/RSP0/CPU0:router(config-t1)# cem-group unframed	Creates an structure agnostic CEM interface.
<b>Step 5</b>	<b>controller t1 e1 <i>interface-path-id</i></b> <b>Example:</b> RP/0/RSP0/CPU0:router(config)# controller t1 0/0/1/0/1	Enters T1 controller configuration submode and specifies the T1 controller name and <i>interface-path-id</i> with the <i>rack/slot/module/port/T1num</i> notation.
<b>Step 6</b>	<b>cem-group framed <i>group-number</i> timeslots <i>range1-range2</i></b> <b>Example:</b> RP/0/RSP0/CPU0:router(config-t1)# cem-group framed 0 timeslots 1	Creates an structure aware CEM interface. The <b>timeslots</b> keyword specifies the time slots for the interface by range with the <i>range1-range2</i> notation.
<b>Step 7</b>	<b>no shutdown</b> <b>Example:</b> RP/0/RSP0/CPU0:router(config-if)# no shutdown	Removes the shutdown configuration.  <b>Note</b> <ul style="list-style-type: none"> <li>Removal of the shutdown configuration eliminates the forced administrative down on the interface, enabling it to move to an up or down state.</li> </ul>
<b>Step 8</b>	<b>end or commit</b> <b>Example:</b> RP/0/RSP0/CPU0:router(config-t1)# end or RP/0/RSP0/CPU0:router(config-t1)# commit	Saves configuration changes.  <ul style="list-style-type: none"> <li>When you issue the <b>end</b> command, the system prompts you to commit changes:                 Uncommitted changes found, commit them before                exiting(yes/no/cancel)?                [cancel]:             </li> </ul>

	Command or Action	Purpose
		<ul style="list-style-type: none"> <li>• Entering <b>yes</b> saves configuration changes to the running configuration file, exits the configuration session, and returns the router to EXEC mode.</li> <li>• Entering <b>no</b> exits the configuration session and returns the router to EXEC mode without committing the configuration changes.</li> <li>• Entering <b>cancel</b> leaves the router in the current configuration session without exiting or committing the configuration changes.</li> <li>• Use the <b>commit</b> command to save the configuration changes to the running configuration file and remain within the configuration session.</li> </ul>
<p><b>Step 9</b></p>	<p><b>show runn interface cem</b> <i>interface-path-id</i></p> <p><b>Example:</b></p> <pre>RP/0/RSP0/CPU0:router# show runn interface cem 0/0/2/0/1:1</pre>	<p>Verifies the CEM interface configuration.</p>

## Configuring the Cisco 2-Port Channelized T3/E3 Circuit Emulation and Channelized ATM SPA and Creating CEM Interface

### T3/E3 Channelization Mode

This task explains how to configure the Cisco 2-Port Channelized T3/E3 Circuit Emulation and Channelized ATM SPA using T3 channelization.



**Note** The T3 channels can be channelized into T1s or E1s, and the T1s or E1s can be channelized further into DS0 time slots, on the Cisco 2-Port Channelized T3/E3 Circuit Emulation and Channelized ATM SPA.

### SUMMARY STEPS

1. **configure**
2. **hw-module subslot** *node-id* **cardtype** {t3| e3}
3. **commit**
4. **controller** {t3|e3} *interface-path-id*
5. **cem-group unframed**
6. **no shutdown**
7. **end** or **commit**
8. **show runn interface cem** *interface-path-id*

## DETAILED STEPS

	Command or Action	Purpose
<b>Step 1</b>	<b>configure</b> <b>Example:</b> RP/0/RSP0/CPU0:router# configure	Enters global configuration mode.
<b>Step 2</b>	<b>hw-module subslot <i>node-id</i> cardtype {t3 e3}</b> <b>Example:</b> RP/0/RSP0/CPU0:router(config-t3)# hw-module subslot 0/3/0 cardtype t3	<p>The <b>hw-module subslot <i>node-id</i> cardtype <i>type</i></b> command configures the SPA to function in t3/e3 mode.</p> <p>Whenever there is a change in framing mode (t3/e3), the SPA will be reloaded automatically. Reload will happen only when all the CEM Interface, T3 Controller configurations are removed completely. This is not applicable when you configure the first time because T3 controller and interface configurations would not exist.</p>
<b>Step 3</b>	<b>commit</b>	Use the <b>commit</b> command to save the configuration changes to the running configuration file and remain within the configuration session.
<b>Step 4</b>	<b>controller {t3 e3} <i>interface-path-id</i></b> <b>Example:</b> RP/0/RSP0/CPU0:router(config)# controller t3 0/0/1/0/4	Enters T3/E3 controller configuration submode and specifies the T3/E3 controller name and <i>interface-path-id</i> with the <i>rack/slot/module/port/T3Num</i> notation.
<b>Step 5</b>	<b>cem-group unframed</b> <b>Example:</b> RP/0/RSP0/CPU0:router(config-t3)# cem-group unframed	Creates an structure agnostic CEM interface. Only the unframed CEM interface is supported in this mode.
<b>Step 6</b>	<b>no shutdown</b> <b>Example:</b> RP/0/RSP0/CPU0:router(config-if)# no shutdown	<p>Removes the shutdown configuration.</p> <p>Removal of the shutdown configuration eliminates the forced administrative down on the interface, enabling it to move to an up or down state.</p>
<b>Step 7</b>	<b>end or commit</b> <b>Example:</b> RP/0/RSP0/CPU0:router(config-t3)# end or RP/0/RSP0/CPU0:router(config-t3)# commit	<p>Saves configuration changes.</p> <ul style="list-style-type: none"> <li>When you issue the <b>end</b> command, the system prompts you to commit changes:   <pre>Uncommitted changes found, commit them before   exiting(yes/no/cancel)? [cancel]:</pre> </li> <li>Entering <b>yes</b> saves configuration changes to the running configuration file, exits the configuration session, and returns the router to EXEC mode.</li> </ul>

	Command or Action	Purpose
		<ul style="list-style-type: none"> <li>Entering <b>no</b> exits the configuration session and returns the router to EXEC mode without committing the configuration changes.</li> <li>Entering <b>cancel</b> leaves the router in the current configuration session without exiting or committing the configuration changes.</li> <li>Use the <b>commit</b> command to save the configuration changes to the running configuration file and remain within the configuration session.</li> </ul>
<b>Step 8</b>	<p><b>show runn interface cem</b> <i>interface-path-id</i></p> <p><b>Example:</b></p> <pre>RP/0/RSP0/CPU0:router# show runn interface cem 0/0/1/0/4:1</pre>	Verifies the CEM interface configuration.

## T1/E1 Channelization Mode

This task explains how to configure the Cisco 2-Port Channelized T3/E3 Circuit Emulation and Channelized ATM SPA using T1/E1 channelization.

### SUMMARY STEPS

- configure**
- hw-module subslot** *node-id* **cardtype** {t3| e3}
- commit**
- controller t3** *interface-path-id*
- mode** {t1|e1}
- controller t1** *interface-path-id*
- cem-group unframed**
- controller t1** *interface-path-id*
- cem-group framed** *group-number* **timeslots** *range1-range2*
- no shutdown**
- end** or **commit**
- show runn interface cem** *interface-path-id*

### DETAILED STEPS

	Command or Action	Purpose
<b>Step 1</b>	<p><b>configure</b></p> <p><b>Example:</b></p> <pre>RP/0/RSP0/CPU0:router# configure</pre>	Enters global configuration mode.

	Command or Action	Purpose
<b>Step 2</b>	<p><b>hw-module subslot <i>node-id</i> cardtype {t3  e3}</b></p> <p><b>Example:</b></p> <pre>RP/0/RSP0/CPU0:router(config-sonet) # hw-module subslot 0/3/0 t3</pre>	<p>The <b>hw-module subslot <i>node-id</i> cardtype <i>type</i></b> command configures the SPA to function in t3/e3 mode.</p> <p>Whenever there is a change in framing mode (t3/e3), the SPA will be reloaded automatically. Reload will happen only when all the CEM Interface, T3 Controller configurations are removed completely. This is not applicable when you configure the first time because T3 controller and interface configurations would not exist.</p>
<b>Step 3</b>	<p><b>commit</b></p>	<p>Use the <b>commit</b> command to save the configuration changes to the running configuration file and remain within the configuration session.</p>
<b>Step 4</b>	<p><b>controller t3 <i>interface-path-id</i></b></p> <p><b>Example:</b></p> <pre>RP/0/RSP0/CPU0:router(config) # controller t3 0/0/1/0/4</pre>	<p>Enters T3 controller configuration submode and specifies the T3 controller name and <i>interface-path-id</i> with the <i>rack/slot/module/port/T3Num</i> notation.</p>
<b>Step 5</b>	<p><b>mode {t1 e1}</b></p>	<p>Sets the mode of interface. The possible modes are T1 and E1 channelization mode.</p>
<b>Step 6</b>	<p><b>controller t1 <i>interface-path-id</i></b></p> <p><b>Example:</b></p> <pre>RP/0/RSP0/CPU0:router(config) # controller t1 0/0/1/0/4/1</pre>	<p>Enters T1 controller configuration submode and specifies the T1 controller name and <i>interface-path-id</i> with the <i>rack/slot/module/port/T3Num/T1num</i> notation.</p>
<b>Step 7</b>	<p><b>cem-group unframed</b></p> <p><b>Example:</b></p> <pre>RP/0/RSP0/CPU0:router(config-t1) # cem-group unframed</pre>	<p>Creates an structure agnostic CEM interface.</p>
<b>Step 8</b>	<p><b>controller t1 <i>interface-path-id</i></b></p> <p><b>Example:</b></p> <pre>RP/0/RSP0/CPU0:router(config) # controller t1 0/0/1/0/4/1</pre>	<p>Enters T1 controller configuration submode and specifies the T1 controller name and <i>interface-path-id</i> with the <i>rack/slot/module/port/T3Num/T1num</i> notation.</p>
<b>Step 9</b>	<p><b>cem-group framed <i>group-number</i> timeslots <i>range1-range2</i></b></p> <p><b>Example:</b></p> <pre>RP/0/RSP0/CPU0:router(config-t1) # cem-group framed 0 timeslots 1</pre>	<p>Creates an structure aware CEM interface. The <b>timeslots</b> keyword specifies the time slots for the interface by range with the <i>range1-range2</i> notation.</p>
<b>Step 10</b>	<p><b>no shutdown</b></p> <p><b>Example:</b></p>	<p>Removes the shutdown configuration.</p>



	Command or Action	Purpose
	RP/0/RSP0/CPU0:router(config-if)# no shutdown	<p><b>Note</b></p> <ul style="list-style-type: none"> <li>Removal of the shutdown configuration eliminates the forced administrative down on the interface, enabling it to move to an up or down state.</li> </ul>
<b>Step 11</b>	<p><b>end or commit</b></p> <p><b>Example:</b></p> <pre>RP/0/RSP0/CPU0:router(config-t1)# end</pre> <p>or</p> <pre>RP/0/RSP0/CPU0:router(config-t1)# commit</pre>	<p>Saves configuration changes.</p> <ul style="list-style-type: none"> <li>When you issue the <b>end</b> command, the system prompts you to commit changes: <pre>Uncommitted changes found, commit them before   exiting(yes/no/cancel)? [cancel]:</pre> </li> <li>Entering <b>yes</b> saves configuration changes to the running configuration file, exits the configuration session, and returns the router to EXEC mode.</li> <li>Entering <b>no</b> exits the configuration session and returns the router to EXEC mode without committing the configuration changes.</li> <li>Entering <b>cancel</b> leaves the router in the current configuration session without exiting or committing the configuration changes.</li> <li>Use the <b>commit</b> command to save the configuration changes to the running configuration file and remain within the configuration session.</li> </ul>
<b>Step 12</b>	<p><b>show runn interface cem interface-path-id</b></p> <p><b>Example:</b></p> <pre>RP/0/RSP0/CPU0:router# show runn interface cem 0/0/2/0/1/1/1/1:1</pre>	<p>Verifies the CEM interface configuration.</p>

## Configuring CEM Interface

This section provides information about how to configure CEM. CEM provides a bridge between a time-division multiplexing (TDM) network and a packet network using Multiprotocol Label Switching (MPLS). The router encapsulates the TDM data in the MPLS packets and sends the data over a CEM pseudowire to the remote provider edge (PE) router.

The following sections describe how to configure CEM:

### Configuration Guidelines and Restrictions

All combinations of payload size and dejitter buffer size are not supported. If you apply an incompatible payload size or dejitter buffer configuration, the router rejects it and reverts to the previous configuration.

## Configuring a Global CEM Class

This task explains how to configure a global CEM class.



**Note** Any interface configuration would have higher precedence over configuration applied through attaching a CEM class. Also, CEM class attached to an interface would have higher precedence than CEM class attached to the parent controller. For example, if the dummy pattern value of *0xcf* is applied directly to an interface and then a CEM class which contains dummy pattern value of *0xaa* is attached to the same interface, then the dummy pattern value would be *0xcf*. The new configuration would not be applied until the dummy pattern value applied directly to the interface is removed.

### SUMMARY STEPS

1. **configure**
2. **cem class** *class-name*
3. **payload** *value*
4. **dejitter** *value*
5. **idle pattern** *value*
6. **dummy mode**
7. **dummy pattern** *value*
8. **end** or **commit**

### DETAILED STEPS

	Command or Action	Purpose
<b>Step 1</b>	<b>configure</b> <b>Example:</b> RP/0/RSP0/CPU0:router# configure	Enters global configuration mode.
<b>Step 2</b>	<b>cem class</b> <i>class-name</i> <b>Example:</b> RP/0/RSP0/CPU0:router(config)# cem class Default	Creates a new CEM class.
<b>Step 3</b>	<b>payload</b> <i>value</i> <b>Example:</b> RP/0/RSP0/CPU0:router(config-cem-class)# payload 512	Enter the payload size for the CEM class.
<b>Step 4</b>	<b>dejitter</b> <i>value</i> <b>Example:</b> RP/0/RSP0/CPU0:router(config-cem-class)# dejitter 10	Enter the dejitter buffer size for the CEM class.

	Command or Action	Purpose
Step 5	<p><b>idle pattern</b> <i>value</i></p> <p><b>Example:</b></p> <pre>RP/0/RSP0/CPU0:router(config-cem-class)# idle pattern 0x55</pre>	Enter the idle pattern value for the CEM class.
Step 6	<p><b>dummy mode</b></p> <p><b>Example:</b></p> <pre>RP/0/RSP0/CPU0:router(config-cem-class)# dummy mode last-frame</pre>	Enter the dummy mode for the CEM class. The options are last-frame or user-defined.
Step 7	<p><b>dummy pattern</b> <i>value</i></p> <p><b>Example:</b></p> <pre>RP/0/RSP0/CPU0:router(config-cem-class)# dummy pattern</pre>	Enter the dummy pattern value for the CEM class. This value is applied only when the dummy mode is user-defined.
Step 8	<p><b>end</b> or <b>commit</b></p> <p><b>Example:</b></p> <pre>RP/0/RSP0/CPU0:router(config-cem-class)# end OR RP/0/RSP0/CPU0:router(config-cem-class)# commit</pre>	<p>Saves configuration changes.</p> <ul style="list-style-type: none"> <li>When you issue the <b>end</b> command, the system prompts you to commit changes: <pre>Uncommitted changes found, commit them before exiting(yes/no/cancel)? [cancel]:</pre> <p>Entering <b>yes</b> saves configuration changes to the running configuration file, exits the configuration session, and returns the router to EXEC mode.</p> <p>Entering <b>no</b> exits the configuration session and returns the router to EXEC mode without committing the configuration changes.</p> <p>Entering <b>cancel</b> leaves the router in the current configuration session without exiting or committing the configuration changes.</p> </li> <li>Use the <b>commit</b> command to save the configuration changes to the running configuration file and remain within the configuration session.</li> </ul>

## Attaching a CEM Class

This task explains how to attach a global CEM class.



**Note** You can attach a CEM class either to a CEM interface or to a T1/E1 controller.

## SUMMARY STEPS

1. **configure**
2. **interface cem** *interface-path-id*
3. (or)
4. **controller {t1|e1}** *interface-path-id*
5. **cem class-attach** *class-name*
6. **end** or **commit**

## DETAILED STEPS

	Command or Action	Purpose
<b>Step 1</b>	<b>configure</b> <b>Example:</b> RP/0/RSP0/CPU0:router# configure	Enters global configuration mode.
<b>Step 2</b>	<b>interface cem</b> <i>interface-path-id</i>	
<b>Step 3</b>	(or)	
<b>Step 4</b>	<b>controller {t1 e1}</b> <i>interface-path-id</i> <b>Example:</b> RP/0/RSP0/CPU0:router(config)# controller t1 0/0/2/0/1/1	Specifies the CEM interface or the T1/E1 controller.
<b>Step 5</b>	<b>cem class-attach</b> <i>class-name</i> <b>Example:</b> RP/0/RSP0/CPU0:router(config)# cem class-attach Default	Attaches the CEM class to an interface or controller.
<b>Step 6</b>	<b>end</b> or <b>commit</b> <b>Example:</b> RP/0/RSP0/CPU0:router(config-cem-class)# end or RP/0/RSP0/CPU0:router(config-cem-class)# commit	Saves configuration changes. <ul style="list-style-type: none"> <li>• When you issue the <b>end</b> command, the system prompts you to commit changes:                 Uncommitted changes found, commit them before                exiting(yes/no/cancel)?                [cancel]:</li> <li>• Entering <b>yes</b> saves configuration changes to the running configuration file, exits the configuration session, and returns the router to EXEC mode.</li> <li>• Entering <b>no</b> exits the configuration session and returns the router to EXEC mode without committing the configuration changes.</li> <li>• Entering <b>cancel</b> leaves the router in the current configuration session without exiting or committing the configuration changes.</li> </ul>

	Command or Action	Purpose
		<ul style="list-style-type: none"> <li>Use the <b>commit</b> command to save the configuration changes to the running configuration file and remain within the configuration session.</li> </ul>

## Configuring Payload Size

To specify the number of bytes encapsulated into a single IP packet, use the **cem payload** command. The size argument specifies the number of bytes in the payload of each packet. The range is from 32 to 1312 bytes.

Default payload sizes for an unstructured CEM channel are as follows:

- E1 = 256 bytes
- T1 = 192 bytes
- E3 = 1024 bytes
- T3 = 1024 bytes

Default payload sizes for a structured CEM channel depend on the number of time slots that constitute the channel. Payload (L in bytes), number of time slots (N), and packetization delay (D in milliseconds) have the following relationship:  $L = 8 * N * D$ .

The default payload size is calculated using the packetization latency depending on the number of time slots the cem interface represents. The relationship between the number of time slots and the packetization latency is provided below:

- For  $N = 1$ , D is 8 milliseconds (with the corresponding packet payloadsize of 64 bytes)
- For  $2 \leq N \leq 4$ , D is 4 milliseconds (with the corresponding packetpayload size of  $32 * N$  bytes)
- For  $N \geq 5$ , D is 1 millisecond (with the corresponding packet payloadsize of  $8 * N$  octets).

Support of 5 ms packetization latency for  $N = 1$  is recommended.

## Setting the Dejitter Buffer Size

To specify the size of the dejitter buffer used to compensate for the network filter, use the **cem dejitter** command. The configured dejitter buffer size is converted from milliseconds to packets and rounded up to the next integral number of packets. Use the size argument to specify the size of the buffer, in milliseconds. The range is from 1 to 500 ms. The following is an example:

```
Router(config-cem)# cem dejitter 5
```

The default dejitter buffer for a CEM channel, irrespective of CESoPSN or SAToP, is as follows:

- E1 = 16 milliseconds
- T1 = 16 milliseconds
- E3 = 5 milliseconds
- T3 = 5 milliseconds



**Note** Refer the T1/E1 SAToP lines:Payload and jitter limits table, the T3/E3 SAToP lines:Payload and jitter limits table, and the ICESoPSN DSo lines:Payload and jitter limits table for the relationship between payload and dejitter buffer on SAToP T1/E1, T3/E3, and CESoPSN lines. Configuration of payload and dejitter should be in accordance with the minimum and maximum values as mentioned in the table.

The maximum and minimum dejitter buffer value, that is the range is fixed for a given payload value.

## Setting an Idle Pattern

To specify an idle pattern, use the [no] **cem idle pattern pattern** command. The payload of each lost CESoPSN data packet must be replaced with the equivalent amount of the replacement data. The range for pattern is from 0x0 to 0xff; the default idle pattern is 0xff. This is an example:

```
Router(config-cem)# cem idle pattern 0xff
```

If the expected CEM packets are not received for a given CEM interface and are considered as being lost, then the CEoP SPA will play out the idle pattern towards the TDM attachment circuit in the respective timeslots configured in the CEM group.

## Enabling Dummy Mode

Dummy mode enables a bit pattern for filling in for lost or corrupted frames. To enable dummy mode, use the **cem dummy mode [last-frame | user-defined]** command. The default is **last-frame**. This is an example:

```
Router(config-cem)# cem dummy mode last-frame
```

When packets are lost due to misordering or where reordering of packets is not successful, the CEoP SPA will play out the Dummy pattern towards the TDM attachment circuit in respective timeslots configured in the CEM group.

## Setting a Dummy Pattern

If dummy mode is set to user-defined, you can use the **cem dummy-pattern** command to configure the dummy pattern. The range for pattern is from 0x0 to 0xff. The default dummy pattern is 0xff. This is an example:

```
Router(config-cem)# cem dummy-pattern 0xff
```

This Table shows the relationship between payload and dejitter for T1/E1 SAToP lines.

T1/E1 SAToP lines: Payload and Jitter Limits

**Table 3:**

T1/E1	Maximum Payload	Maximum Jitter	Minimum Jitter	Minimum Payload	Maximum Jitter	Minimum Jitter
T1	960	320	10	192	64	2
E1	1280	320	10	256	64	2

This table shows the relationship between payload and dejitter for T3/E3 SAToP lines.

T3/E3 SAToP lines: Payload and Jitter Limits

**Table 4:**

<b>T3/E3</b>	<b>Maximum Payload</b>	<b>Maximum Jitter</b>	<b>Minimum Jitter</b>	<b>Minimum Payload</b>	<b>Maximum Jitter</b>	<b>Minimum Jitter</b>
T3	1312	8	2	672	8	2
E3	1312	16	2	512	8	2

This table shows the relationship between payload and dejitter for DS0 lines.

CESoPSN DS0 Lines: Payload and Jitter Limits

**Table 5:**

<b>DS0</b>	<b>Maximum Payload</b>	<b>Maximum Jitter</b>	<b>Minimum Jitter</b>	<b>Minimum Payload</b>	<b>Maximum Jitter</b>	<b>Minimum Jitter</b>
1	40	320	10	32	256	8
2	80	320	10	32	128	4
3	120	320	10	33	128	4
4	160	320	10	32	64	2
5	200	320	10	40	64	2
6	240	320	10	48	64	2
7	280	320	10	56	64	2
8	320	320	10	64	64	2
9	360	320	10	72	64	2
10	400	320	10	80	64	2
11	440	320	10	88	64	2
12	480	320	10	96	64	2
13	520	320	10	104	64	2
14	560	320	10	112	64	2
15	600	320	10	120	64	2
16	640	320	10	128	64	2
17	680	320	10	136	64	2
18	720	320	10	144	64	2
19	760	320	10	152	64	2

DS0	Maximum Payload	Maximum Jitter	Minimum Jitter	Minimum Payload	Maximum Jitter	Minimum Jitter
20	800	320	10	160	64	2
21	840	320	10	168	64	2
22	880	320	10	176	64	2
23	920	320	10	184	64	2
24	960	320	10	192	64	2
25	1000	320	10	200	64	2
26	1040	320	10	208	64	2
27	1080	320	10	216	64	2
28	1120	320	10	224	64	2
29	1160	320	10	232	64	2
30	1200	320	10	240	64	2
31	1240	320	10	248	64	2
32	1280	320	10	256	64	2

## Configuring Clocking

Each SPA port shall be configured either to use system clock from the host card or loop timed independently. Each SPA also supplies a reference clock to the host which can be selected among the received port clocks. This section provides information about how to configure clocking on the 1xOC3 SPA.

This section describes the following topics:

### Configuring Clock Recovery

When configuring clock recovery, consider the following guidelines:

#### Adaptive Clock Recovery

- Clock source:
  - In Cisco IOS XR Release 4.2.x and later, recovered clock from a CEM interface on the 1-Port Channelized OC-3/STM1 CEoP SPA can be used as a clock source on the SPA itself.
- Number of clock sources allowed:
  - Refer the section [Clock Distribution](#) for more information.
- The clock must be the same as used by the router as the network clock. Any pseudowire in this case can carry the clock.



- The minimum bundle size of CEM pseudowires on the network that delivers robust clock recovery is 4 DS0s.
- The minimum packet size of CEM pseudowires on the network that delivers robust clock recovery is 64 bytes.

## Differential Clocking

- The maximum number of differential clocks sourced from a 1-Port Channelized OC-3/STM1 CEoP SPA is 10.
- The 1-Port Channelized OC-3/STM1 CEoP SPA can recover up to 10 T1/E1 clocks.
- There are several bundles sent from the same port. The bundle that is used for carrying the clock of the port is the first created bundle of the port. Only pseudowires that include the first DS0 of a port can carry differential clock.
- You must have a Stratum-1 clock, a common clock going to both PE routers. If not, the recovery will not work as expected.

To configure clock recovery on the CEoP SPA and to apply the recovered clock to the controller, use the following procedure:

### SUMMARY STEPS

1. **configure**
2. **interface cem rack/slot/subslot/port:cem-group**
3. **transmit-clock {differential}**
4. **recover-clock clock-id {adaptive | differential}**
5. **controller name instance**
6. **clock source recovered clock-id**

### DETAILED STEPS

	Command or Action	Purpose
Step 1	<b>configure</b> <b>Example:</b> RP/0/RSP0/CPU0:router# configure	Enters global configuration mode.
Step 2	<b>interface cem rack/slot/subslot/port:cem-group</b> <b>Example:</b> RP/0/RSP0/CPU0:router(config)# interface cem 0/1/0/0:2	Specifies the complete CEM interface instance.
Step 3	<b>transmit-clock {differential}</b> <b>Example:</b> RP/0/RSP0/CPU0:router(config-if)# transmit-clock source internal	Configures the CEM port transmit clock source. This is typically configured at the node acting as primary to send the clock. This command is not required for Adaptive Clock Recovery.

	Command or Action	Purpose
<b>Step 4</b>	<b>recover-clock</b> <i>clock-id</i> { <b>adaptive</b>   <b>differential</b> } <b>Example:</b> RP/0/RSP0/CPU0:router(config-if)# recover-clock clock-id <> adaptive	Specifies the recovered clock number and the clock recovery type. This is typically configured at the node acting as subordinate that recovers the clock from incoming CEM packets from core.
<b>Step 5</b>	<b>controller</b> <i>name instance</i> <b>Example:</b> RP/0/RSP0/CPU0:router(config)# controller t1 0/1/1/0/0/0	Enters controller configuration submode and specifies the controller name and instance identifier with the <i>rack/slot/module/port/name/instance1/instance2</i> notation.
<b>Step 6</b>	<b>clock source recovered</b> <i>clock-id</i> <b>Example:</b> RP/0/RSP0/CPU0:router(config-t1)# clock source recovered 3	Specifies the recovered clock number. This applies the recovered clock from a CEM interface on a T1/E1 Controller.

## Verifying Clock recovery

To verify clock recovery, use the **show recovered-clock** command.

```
Router# show recovered-clock subslot 0/3/0
Recovered clock status for subslot 0/3/0
-----
Clock    Mode           Port CEM  Status      Frequency Offset(ppb)
1        ADAPTIVE       0    1    HOLDOVER    0
Router# show recovered-clock
Recovered clock status for subslot 3/0
-----
Clock    Mode           Port CEM  Status      Frequency Offset(ppb)
1        ADAPTIVE       0    1    ACQUIRING   -694
```

## Show Commands for CEM

You can use the command **show controller cem** <*forward interface instance*> to verify the CEM parameter information. The following example provides a sample output for the command.

## Output of show controller cem forward interface instance command

```
RP/0/RSP0/CPU0:Router# show controllers cem 0/4/1/0:0

Interface           : CEM0/4/1/0:0
Admin state         : Up
Driver link state   : Up
Port bandwidth(kbps) : 1984
Dejitter buffer     : 16
Payload size        : 248
Dummy mode          : last-frame
Dummy pattern       : 0xff
Idle pattern        : 0xff
Signalling          : No CAS
```

```

RTP                               : Enabled
Ingress packets                   : 1638960097, Ingress packets drop      : 0
Egress packets                    : 1207954294, Egress packets drop     : 287140468
Missing packets                   : 160475876, Reordered packets        : 50092
Malformed packets                 : 73, Misorder drops                  : 7
Jitter buffer underrun           : 28, Error seconds                   : 79673
Severely error seconds           : 25721, Unavailable seconds          : 160361
Failure counts                    : 2

```

## Configuration Examples for CEM

This section contains the following examples:

### Circuit Emulation Interface Configuration: Examples

The following example shows a sample CEM interface configuration on the Cisco 1-port Channelized OC3/STM-1 SPA.

#### Channelized Sonet / SDH Configurations and CEM Interface Creation

The following examples shows a Channelized Sonet/ SDH Configurations and CEM Interface Creation.

#### Sonet - T1 Channelization and CEM Interface Creation

```

hw-module subslot <loc> cardtype sonet
controller SONET 0/0/1/0
  sts 1
    mode vt15-t1
  sts 2
    mode vt15-t1
  sts 3
    mode vt15-t1
commit

```

**In case of structure agnostic cem interface:**

```

controller T1 0/0/1/0/1/4/1
cem-group unframed

```

**In case of structure aware cem interface:**

```

controller T1 0/0/1/0/1/5/1
cem-group framed 0 timeslots 1
cem-group framed 1 timeslots 2-3
cem-group framed 2 timeslots 4-6
cem-group framed 3 timeslots 7-10
cem-group framed 4 timeslots 11-15
cem-group framed 5 timeslots 16-21
cem-group framed 6 timeslots 22-24

```

#### SDH - T1 Channelization and CEM Interface Creation

```

hw-module subslot <loc> cardtype sdh
controller SONET0/0/2/0

```

```

au 1
 mode c11-t1
au 2
 mode c11-t1
au 3
 mode c11-t1
commit

```

**In case of structure agnostic cem interface:**

```

controller T1 0/0/2/0/1/1/4
 cem-group unframed

```

**In case of structure aware cem interface:**

```

controller T1 0/0/2/0/1/7/1
 cem-group framed 0 timeslots 1
 cem-group framed 1 timeslots 2-3
 cem-group framed 2 timeslots 4-6
 cem-group framed 3 timeslots 7-10
 cem-group framed 4 timeslots 11-15
 cem-group framed 5 timeslots 16-21
 cem-group framed 6 timeslots 22-24

```

## SDH - E1 Channelization and CEM Interface Creation

```

hw-module subslot <loc> cardtype sdh
controller SONET 0/0/2/0
 au 1
  mode tug3
  width 3
  tug3 1
  mode c12-e1
 tug3 2
  mode c12-e1
 tug3 3
  mode c12-e1
commit

```

**In case of structure agnostic cem interface:**

```

controller E1 0/0/2/0/1/1/1/1
 cem-group unframed

```

**In case of structure aware cem interface:**

```

controller E1 0/0/2/0/1/1/7/1
 cem-group framed 0 timeslots 1
 cem-group framed 1 timeslots 2-3
 cem-group framed 2 timeslots 4-6
 cem-group framed 3 timeslots 7-10
 cem-group framed 4 timeslots 11-15
 cem-group framed 5 timeslots 16-21
 cem-group framed 6 timeslots 22-31

```

## CEM Interface Configuration

```

RP/0/RSP0/CPU0:CEOP-01#show runn interface cem 0/0/2/0/1/1/1/1:1

interface CEM0/0/2/0/1/1/1/1:1

```

```

l2transport
!
CEM Interface Config Options :

RP/0/RSP0/CPU0:CEOP-01(config)#interface cem 0/0/2/0/1/1/1/1:1
RP/0/RSP0/CPU0:CEOP-01(config-if)#cem ?
  class-attach  Attach a CEM class to this interface
  clock         Configure clocks on this CEM interface
  dejitter     Configure dejitter buffer
  dummy        Configure dummy frame parameters
  idle         Configure idle frame parameters
  payload      Configure payload size of CEM frames

```

## SAToP CEM interface creation on T3 / E3 on Cisco 2-Port Channelized T3/E3 Circuit Emulation and Channelized ATM SPA

```

RP/0/0/CPU0:router(config)#controller t3 0/4/2/0
RP/0/0/CPU0:router(config-t3)#cem-group ?
  unframed  clear channel carrying CEM
RP/0/0/CPU0:router(config-t3)#cem-group unframed
RP/0/0/CPU0:router(config-t3)#commit
RP/0/0/CPU0:router(config-t3)#

```

## SAToP CEM interface creation on T1 / E1 on Cisco 2-Port Channelized T3/E3 Circuit Emulation and Channelized ATM SPA

```

RP/0/0/CPU0:router(config)#controller t3 0/4/2/0
RP/0/0/CPU0:router(config-t3)#mode ?
  atm      clear channel carrying atm
  e1      channelize into 21 E1s
  serial  clear channel carrying hdlc like payload
  t1      channelized into 28 T1s
RP/0/0/CPU0:router(config-t3)#mode e1
RP/0/0/CPU0:router(config-t3)#commit

RP/0/0/CPU0:router(config)#controller e1 0/4/2/0/1
RP/0/0/CPU0:router(config-e1)#cem-group ?
  framed   Configure a framed CEM interface on T1/E1
  unframed Configure a unframed CEM interface on T1/E1
RP/0/0/CPU0:router(config-e1)#cem-group unframed ?
<cr>
RP/0/0/CPU0:router(config-e1)#cem-group unframed
RP/0/0/CPU0:router(config-e1)#commit

```

## CESoPSN CEM interface creation on T1/E1 on Cisco 2-Port Channelized T3/E3 Circuit Emulation and Channelized ATM SPA

```

RP/0/0/CPU0:router(config)#controller t3 0/4/2/1
RP/0/0/CPU0:router(config-t3)#mode ?
  atm      clear channel carrying atm
  e1      channelize into 21 E1s
  serial  clear channel carrying hdlc like payload
  t1      channelized into 28 T1s
RP/0/0/CPU0:router(config-t3)#mode t1
RP/0/0/CPU0:router(config-t3)#commit

RP/0/0/CPU0:router(config)#controller t1 0/4/2/1/1
RP/0/0/CPU0:router(config-t1)#cem-group ?

```

```

    framed    Configure a framed CEM interface on T1/E1
    unframed  Configure a unframed CEM interface on T1/E1
RP/0/0/CPU0:router(config-t1)#cem-group framed ?
    <0-23>    CEM group number
RP/0/0/CPU0:router(config-t1)#cem-group framed 0 ?
    timeslots List of timeslots in the CEM group
RP/0/0/CPU0:router(config-t1)#cem-group framed 0 timeslots ?
    WORD     timeslot string separated by (:) or (-) from 1 to 24. (:) indicates individual
timeslot and (-) represent range
RP/0/0/CPU0:router(config-t1)#cem-group framed 0 timeslots 1:23
RP/0/0/CPU0:router(config-t1)#commit

```

## SAToP CEM interface creation on T1 / E1 on Cisco 24-Port Channelized T1/E1 Circuit Emulation and Channelized ATM SPA

```

RP/0/0/CPU0:router(config)#controller e1 0/4/1/2
RP/0/0/CPU0:router(config-e1)#cem-group ?
    framed    Configure a framed CEM interface on T1/E1
    unframed  Configure a unframed CEM interface on T1/E1
RP/0/0/CPU0:router(config-e1)#cem-group unframed ?
    <cr>
RP/0/0/CPU0:router(config-e1)#cem-group unframed
RP/0/0/CPU0:router(config-e1)#commit

```

## CESoPSN CEM interface creation on T1 / E1 on Cisco 24-Port Channelized T1/E1 Circuit Emulation and Channelized ATM SPA

```

RP/0/0/CPU0:router(config)#controller e1 0/4/1/1
RP/0/0/CPU0:router(config-e1)#cem-group framed ?
    <0-30>    CEM group number
RP/0/0/CPU0:router(config-e1)#cem-group framed 1 ?
    timeslots List of timeslots in the CEM group
RP/0/0/CPU0:router(config-e1)#cem-group framed 1 timeslots ?
    WORD     timeslot string separated by (:) or (-) from 1 to 31. (:) indicates individual
timeslot and (-) represent range
RP/0/0/CPU0:router(config-e1)#cem-group framed 1 timeslots 1:20
RP/0/0/CPU0:router(config-e1)#commit

```

## Clock Recovery: Example

### Adaptive Clock Recovery Configuration:

(E1 configurations are similar to T1s given below)

#### CE1

----

```

Router (config)#controller t1 0/0/2/0/1/1/4
Router (config-t1)#clock source internal

```

PE1 (Acts as source of clock, but no specific configuration under CEM Interface is needed here)

```

-----
Router (config)#controller t1 0/0/2/0/1/1/4
Router (config-t1)#clock source line

```

PE2 (On PE node where clock recovery is done):

-----

To recover the adaptive clock:

```
Router(config)# interface cem 0/0/2/0/1/1/4:0
Router(config-if)#cem clock recover <clock-id> adaptive
```

To apply the recovered clock,

```
Router (config)#controller t1 0/0/2/0/1/1/4
Router (config-t1)#clock source recovered <clock-id>
```

**CE2**

----

```
Router (config)#controller t1 0/0/2/0/1/1/4
Router (config-t1)#clock source line
```

## Differential Clock Recovery Configuration:

**CE1**

----

```
Router (config)#controller t1 0/0/2/0/1/1/4
Router (config-t1)#clock source internal
```

PE1 (Acts as source of clock)

-----

```
Router (config)#controller t1 0/0/2/0/1/1/4
Router (config-t1)#clock source line
Router(config)# interface cem 0/0/2/0/1/1/4:0
Router(config-if)#cem clock transmit differential
```

PE2 (To recover the differential clock):

-----

```
Router (config)#interface cem 0/0/2/0/1/1/4:0
Router (config-t1)#cem clock recover <clock-id> differential
```

To apply the recovered clock:

```
Router (config)#controller t1 0/0/2/0/1/1/4
Router (config-t1)#cem clock recovered <clock-id>
```

**CE2**

----

```
Router (config)#controller t1 0/0/2/0/1/1/4
Router (config-t1)#clock source line
```

Differential Clock Recovery Configuration: